



**Model Number**

**FLT-8-H-2800-50/120a**

Area scanner  
with connector, Binder series 581, 5-pin

**Features**

- Area scanner with long detection range for detecting people and objects
- Version with Background suppression
- Ignores objects outside of selected area
- Version with detection area 50 mm x 500 mm

**Product information**

The FLT-8 series active infra-red area scanners detect people and objects located within a defined sensing field, regardless of background and whether or not they are moving. The sensors generate a clearly defined spatial sensing field, which can be mechanically adjusted. This sensing field is comprised of three or four individual light beams.

**Dimensions**

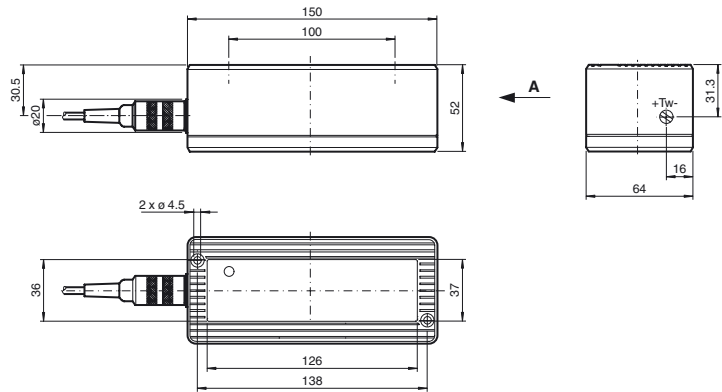

**Electrical connection**

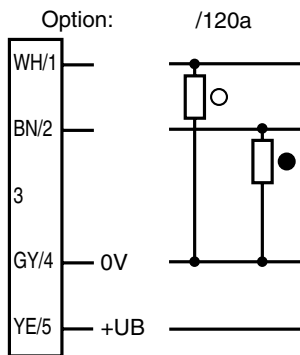

- = Light on
- = Dark on

**Indicators/operating means**

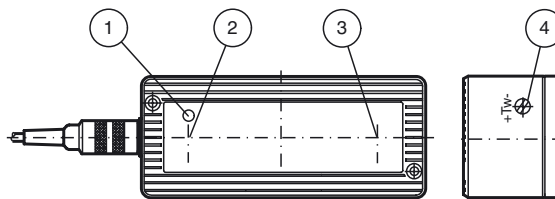

1	Functional display	red
2	Emitter	
3	Receiver	
4	Detection range adjuster	

Release date: 2013-12-16 12:53 Date of issue: 2013-12-16 419507\_eng.xml

Refer to "General Notes Relating to Pepperl+Fuchs Product Information".

Pepperl+Fuchs Group  
www.pepperl-fuchs.com

USA: +1 330 486 0001  
fa-info@us.pepperl-fuchs.com

Germany: +49 621 776 4411  
fa-info@de.pepperl-fuchs.com

Singapore: +65 6779 9091  
fa-info@sg.pepperl-fuchs.com

**Technical data****General specifications**

Detection field	50 mm x 500 mm at 2000 mm sensor range
Detection range min.	100 ... 1200 mm
Detection range max.	100 ... 2800 mm
Light source	3 x IRED
Light type	modulated infrared light
Light spot representation	43 mm x 43 mm at 2000 mm
Marking	CE
Operating mode	Background suppression

**Functional safety related parameters**

MTTF <sub>d</sub>	470 a
Mission Time (T <sub>M</sub> )	20 a
Diagnostic Coverage (DC)	0 %

**Indicators/operating means**

Function indicator	LED red
Control elements	Detection range adjuster

**Electrical specifications**

Operating voltage	U <sub>B</sub>	15 ... 48 V DC
No-load supply current	I <sub>0</sub>	100 mA
Power consumption	P <sub>0</sub>	2.5 W

**Output**

Switching type	light/dark on
Signal output	2 PNP, complementary, short-circuit protected, open collectors
Switching voltage	48 V DC
Switching current	200 mA
Response time	100 ms
De-energized delay	t <sub>off</sub> 200 ms

**Ambient conditions**

Ambient temperature	-20 ... 60 °C (-4 ... 140 °F)
Storage temperature	-20 ... 75 °C (-4 ... 167 °F)

**Mechanical specifications**

Mounting height	max. 2800 mm
Protection degree	IP65
Connection	Connector, Binder series 581, 5-pin
Material	
Housing	Makrolon GV30 black
Optical face	Glass, red
Mass	320 g

**General information**

Scope of delivery	2 m Connecting cable
-------------------	----------------------

**Compliance with standards and directives**

Standard conformity	
Product standard	EN 60947-5-2:2007 IEC 60947-5-2:2007
Emitted interference	EN 61000-6-3
Standards	EN 61000-6-2 without EN 61000-4-5, EN 61000-4-11

**Typical applications**

- Protection mechanism for closing edges on automatic doors and gates
- Monitoring hazardous areas, such as crushing or shearing edges
- Anti-collision protection on automated guided vehicles
- Presence checks for people

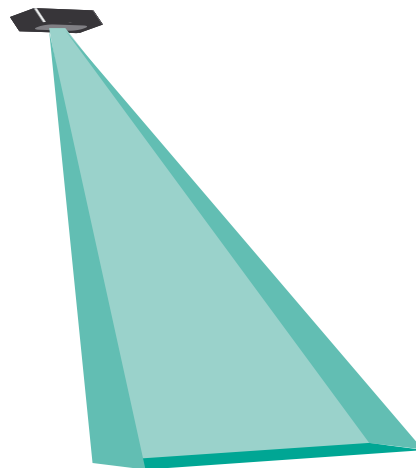
**Detection area****Accessories****Montageplatte FLT**

Mounting plate for FLT-8 series sensors

**FLT-50-AR**

alignment aid for FLT...-50

Other suitable accessories can be found at [www.pepperl-fuchs.com](http://www.pepperl-fuchs.com)

## Curves/Diagrams

Size of detection field  
FLT...-50

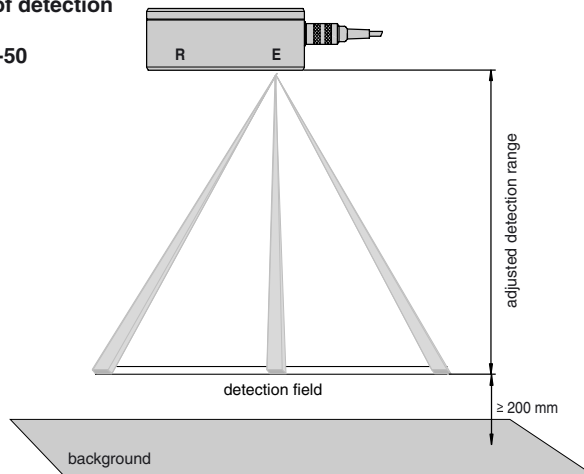

Detection field size versus adjusted detection range:

detect. field	detection field size	spot size
1500 mm	380 mm x 38 mm	30 mm x 30 mm
1800 mm	450 mm x 50 mm	35 mm x 35 mm
2000 mm	500 mm x 50 mm	43 mm x 43 mm
2500 mm	610 mm x 61 mm	57 mm x 57 mm
2800 mm	685 mm x 68 mm	64 mm x 64 mm

## Functional specifications

The FLT-8-H serves to detect persons and objects as they enter the detection range of the device. The device responds at the moment the object to be detected is hit by at least one of the light beams. The sensor functions as a sensing device with background suppression.

In case the background (floor, wall) produces permanent or temporary sparkling reflections, e. g. due to wetness, the sensor needs to be turned by at least 5° around its longitudinal axis during installation to prevent mirror effects (fig).

Several sensors can be arranged in such a way that their scanned areas can border on each other directly or overlap without any switching error occurring.

The light scanner function is displayed by a red LED which can be observed through the front disc.

