



Model Number

RL28-8-H-1500-LAS/47/115b

Background suppression sensor with 0.2 m fixed cable and 4-pin, M12 connector

Features

- Universal series with highly versatile fields of use
- Resistant against noise: reliable operation under all conditions
- Laser version for long ranges
- Small light beam diameter for detection of small parts

Dimensions

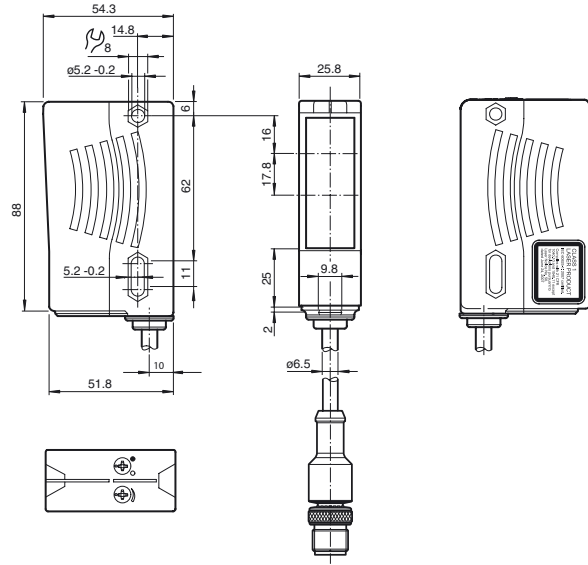

Electrical connection

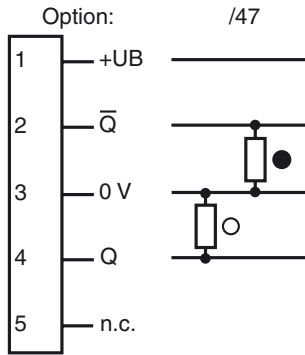

○ = Light on
● = Dark on

Pinout

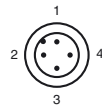

Wire colors in accordance with EN 60947-5-2

1	BN	(brown)
2	WH	(white)
3	BU	(blue)
4	BK	(black)

Indicators/operating means

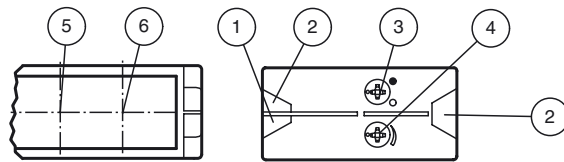

1	Operating display green
2	Switch state yellow
3	Bright/dark switch
4	Detection range adjuster
5	Receiver
6	Emitter

Release date: 2018-03-26 09:53 Date of issue: 2018-03-26 194926_eng.xml

Refer to "General Notes Relating to Pepperl+Fuchs Product Information".

Pepperl+Fuchs Group
www.pepperl-fuchs.com

USA: +1 330 486 0001
fa-info@us.pepperl-fuchs.com

Germany: +49 621 776 4411
fa-info@de.pepperl-fuchs.com

Singapore: +65 6779 9091
fa-info@sg.pepperl-fuchs.com

Technical data**General specifications**

Detection range	100 ... 1500 mm
Detection range min.	50 ... 200 mm
Detection range max.	100 ... 1500 mm
Background suppression	max. + 10 % of the upper limit of the detection range
Light source	laser diode
Light type	modulated visible red light

Laser nominal ratings

Note LASER LIGHT , DO NOT STARE INTO BEAM

Laser class	1
Wave length	650 nm
Beam divergence	< 1.5 mrad
Pulse length	4.5 µs
Repetition rate	approx. 1.5 kHz
max. pulse energy	17 nJ
Light spot representation	max. 1.5 mm x 4 mm , light spot perpendicular to housing
Black/White difference (6 %/90 %)	≤ 40 %
Ambient light limit	50000 Lux

Functional safety related parameters

MTTF _d	590 a
Mission Time (T _M)	20 a
Diagnostic Coverage (DC)	0 %

Indicators/operating means

Operation indicator	LED green
Function indicator	2 LEDs yellow ON: object inside the scanning range OFF: object outside the scanning range
Control elements	Sensing range adjuster , Light-on/dark-on changeover switch

Electrical specifications

Operating voltage	U _B	10 ... 30 V DC
Ripple		10 %
No-load supply current	I ₀	≤ 40 mA
Protection class		II, rated insulation voltage ≤ 250 V AC with pollution degree 1-2 according to IEC 60664-1
Time delay before availability	t _v	≤ 2 s

Output

Switching type	light/dark on, switchable	
Signal output	2 PNP outputs, complementary, short-circuit protected, reverse polarity protected, open collector	
Switching voltage	max. 30 V DC	
Switching current	max. 200 mA	
Switching frequency	f	140 Hz
Response time		3.5 ms

Conformity

Product standard	EN 60947-5-2
Laser safety	EN 60825-1

Ambient conditions

Ambient temperature	-10 ... 50 °C (14 ... 122 °F)
Storage temperature	-25 ... 75 °C (-13 ... 167 °F)

Mechanical specifications

Housing width	25.8 mm
Housing height	88 mm
Housing depth	54.3 mm
Degree of protection	IP67
Connection	0.2 m fixed cable with 4-pin, M12 connector
Material	
Housing	Plastic ABS
Optical face	Plastic pane
Mass	approx. 70 g

Approvals and certificates

Protection class	II, rated voltage ≤ 250 V AC with pollution degree 1-2 according to IEC 60664-1
UL approval	E87056 , cULus Listed , class 2 power supply , type rating 1
FDA approval	IEC 60825-1:2007 Complies with 21 CFR 1040.10 and 1040.11 except for deviations pursuant to Laser Notice No. 50, dated June 24, 2007

Laserlabel**CLASS 1
LASER PRODUCT**

IEC 60825-1: 2007 certified.

Complies with 21 CFR 1040.10 and 1040.11 except for deviations pursuant to Laser Notice No. 50, dated June 24, 2007

Accessories**OMH-05**

Mounting aid for round steel ø 12 mm or sheet 1.5 mm ... 3 mm

OMH-07

Mounting aid for round steel ø 12 mm or sheet 1.5 mm ... 3 mm

OMH-21

Mounting bracket

OMH-22

Mounting bracket

OMH-MLV11-K

dove tail mounting clamp

OMH-RLK29-HW

Mounting bracket for rear wall mounting

OMH-RL28-C

Weld slag cover model

Other suitable accessories can be found at www.pepperl-fuchs.com

Curves/Diagrams

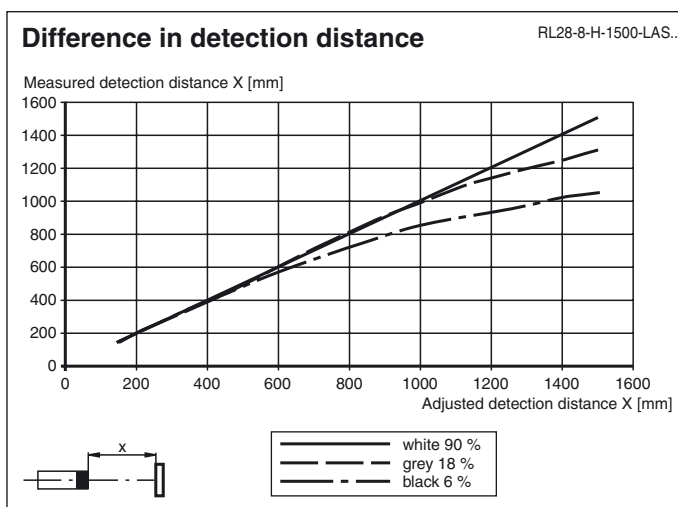
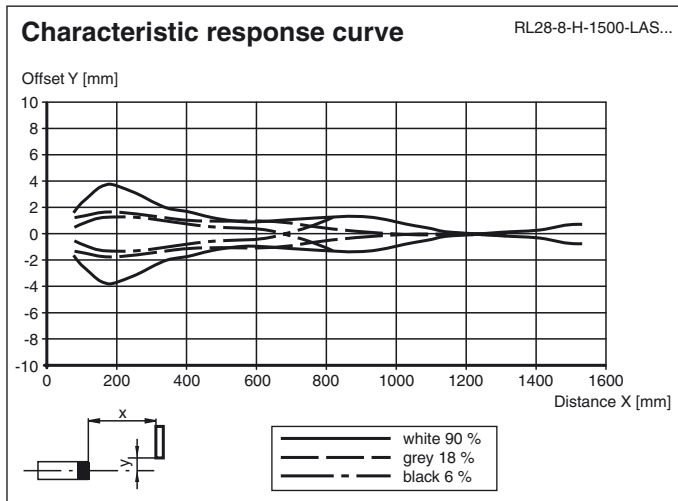

Laser notice laser class 1

- The irradiation can lead to irritation especially in a dark environment. Do not point at people!
- Maintenance and repairs should only be carried out by authorized service personnel!
- Attach the device so that the warning is clearly visible and readable.
- Caution – Use of controls or adjustments or performance of procedures other than those specified herein may result in hazardous radiation exposure.