

PSEN sl-0.5p 3.1/4.1/4.2

PSEN sensor technology

pilz

This document is the original document.

All rights to this documentation are reserved by Pilz GmbH & Co. KG. Copies may be made for internal purposes. Suggestions and comments for improving this documentation will be gratefully received.

Pilz®, PIT®, PMI®, PNOZ®, Primo®, PSEN®, PSS®, PVIS®, SafetyBUS p®, SafetyEYE®, SafetyNET p®, the spirit of safety® are registered and protected trademarks of Pilz GmbH & Co. KG in some countries.



SD means Secure Digital

Introduction	5
Validity of documentation	5
Using the documentation	5
Definition of symbols	5
Safety	6
Intended use	6
Safety regulations	7
Safety assessment	7
Use of qualified personnel	7
Warranty and liability	7
Disposal	7
Unit features	8
Function description	9
Lateral and vertical offset	11
Wiring	11
Guidelines for cable length	11
Recommended cable cross sections	12
Pin assignment	12
Connection to evaluation devices	12
Connection example PNOZ s3	15
Connection example PNOZmulti	16
Teaching in the actuator	16
PSEN sl-0.5p 3.1	16
PSEN sl-0.5p 4.1	16
PSEN sl-0.5p 4.2	17
Installation	17
Note regarding the free-moving actuator PSEN sl-0.5fm	19
Installing on a swing gate	20
Installing on a sliding gate	21
Adjustment	22
Operation	22
Error display through flashing codes	23
Dimensions in mm	25
Technical Details Order No. 570570-570572	26
Technical Details Order No. 570573-570575	29

Status of the applied standards	32
Safety characteristic data	32
Order reference	33
Safety gate system	33
Accessories	33
EC declaration of conformity	33

Introduction

Validity of documentation

This documentation is valid for the products PSEN sl-0.5p 3.1/4.1/4.2. It is valid until new documentation is published.

This operating manual explains the function and operation, describes the installation and provides guidelines on how to connect the product.

Using the documentation

This document is intended for instruction. Only install and commission the product if you have read and understood this document. The document should be retained for future reference.

Definition of symbols

Information that is particularly important is identified as follows:



DANGER!

This warning must be heeded! It warns of a hazardous situation that poses an immediate threat of serious injury and death and indicates preventive measures that can be taken.



WARNING!

This warning must be heeded! It warns of a hazardous situation that could lead to serious injury and death and indicates preventive measures that can be taken.



CAUTION!

This refers to a hazard that can lead to a less serious or minor injury plus material damage, and also provides information on preventive measures that can be taken.



NOTICE





This describes a situation in which the product or devices could be damaged and also provides information on preventive measures that can be taken. It also highlights areas within the text that are of particular importance.

**INFORMATION**

This gives advice on applications and provides information on special features.

Safety**Intended use**

The safety gate system meets the requirements in accordance with

- ▶ EN 60204-1:2006
- ▶ EN 60947-5-3:2005: PDF-M with the corresponding actuator PSEN sl0.5 or PSEN sl0.5fm (see Technical details: [System with normal actuator](#)  26], [System with free-moving actuator](#)  29], under mechanical data)
- ▶ EN 62061:2005: SIL CL 3
- ▶ EN ISO 13849-1:2008: PL e and Cat. 4
- ▶ The safety switch may only be used with the corresponding actuator (see Technical details: [System with normal actuator](#)  26], [System with free-moving actuator](#)  29], under mechanical data).

The safety level PL e (Cat. 4)/SIL CL 3 is only achieved if

- ▶ the safety outputs use 2-channel processing.

The following is deemed improper use in particular:

- ▶ Any component, technical or electrical modification to the product
- ▶ Use of the product outside the areas described in this manual
- ▶ Use of the product outside the technical details (see chapter entitled "Technical Details").

**NOTICE**

EMC-compliant electrical installation

The product is designed for use in an industrial environment. The product may cause interference if installed in other environments. If installed in other environments, measures should be taken to comply with the applicable standards and directives for the respective installation site with regard to interference.

**INFORMATION**

The magnet surface and counterplate may heat up. When installing, make sure that heat dissipation is guaranteed.

**INFORMATION**

Do not remove the protective cap until you are just about to connect the unit.

Safety regulations**Safety assessment**

Before using a unit it is necessary to perform a safety assessment in accordance with the Machinery Directive.

Functional safety is guaranteed for the product as a single component. However, this does not guarantee the functional safety of the overall plant/machine. In order to achieve the required safety level for the overall plant/machine, define the safety requirements for the plant/machine and then define how these must be implemented from a technical and organisational standpoint.

Use of qualified personnel

The products may only be assembled, installed, programmed, commissioned, operated, maintained and decommissioned by competent persons.

A competent person is someone who, because of their training, experience and current professional activity, has the specialist knowledge required to test, assess and operate the work equipment, devices, systems, plant and machinery in accordance with the general standards and guidelines for safety technology.

It is the company's responsibility only to employ personnel who:

- ▶ Are familiar with the basic regulations concerning health and safety / accident prevention
- ▶ Have read and understood the information provided in this description under "Safety"
- ▶ And have a good knowledge of the generic and specialist standards applicable to the specific application.

Warranty and liability

All claims to warranty and liability will be rendered invalid if

- ▶ The product was used contrary to the purpose for which it is intended
- ▶ Damage can be attributed to not having followed the guidelines in the manual
- ▶ Operating personnel are not suitably qualified
- ▶ Any type of modification has been made (e.g. exchanging components on the PCB boards, soldering work etc.).

Disposal

- ▶ In safety-related applications, please comply with the mission time T_M in the safety-related characteristic data.
- ▶ When decommissioning, please comply with local regulations regarding the disposal of electronic devices (e.g. Electrical and Electronic Equipment Act).

Unit features

- ▶ Transponder technology for presence detection (safety function)
- ▶ Unit types with coding (measure to minimise defeat possibilities in accordance with ISO 14119):
 - PSEN sl-0.5p 3.1: coded
 - PSEN sl-0.5p 3.1: coded, with free-moving actuator PSEN sl-0.5fm
 - PSEN sl-0.5p 4.1: fully coded
 - PSEN sl-0.5p 4.1: fully coded, with free-moving actuator PSEN sl-0.5fm
 - PSEN sl-0.5p 4.2: uniquely coded
 - PSEN sl-0.5p 4.2: uniquely coded, with free-moving actuator PSEN sl-0.5fm
- ▶ Units available with two different actuators
 - Standard actuator PSEN sl-0.5 with normal actuator plate for standard applications
 - Free-moving actuator PSEN sl-0.5fm with free-moving actuator plate for special applications
- ▶ Dual-channel operation
- ▶ 2 safety outputs
- ▶ 2 safety inputs for series connection of multiple safety switches
- ▶ 1 signal output
- ▶ Magnetic guard locking for process protection
- ▶ Safety outputs switch independently of the status of the magnetic guard locking device
- ▶ 1 input to switch the locking magnet on/off
- ▶ LEDs for
 - Supply voltage/fault
 - Gate closed
 - State of the inputs
 - State of the magnetic guard locking device
- ▶ 8 pin M12 male connector

Function description

Block diagram

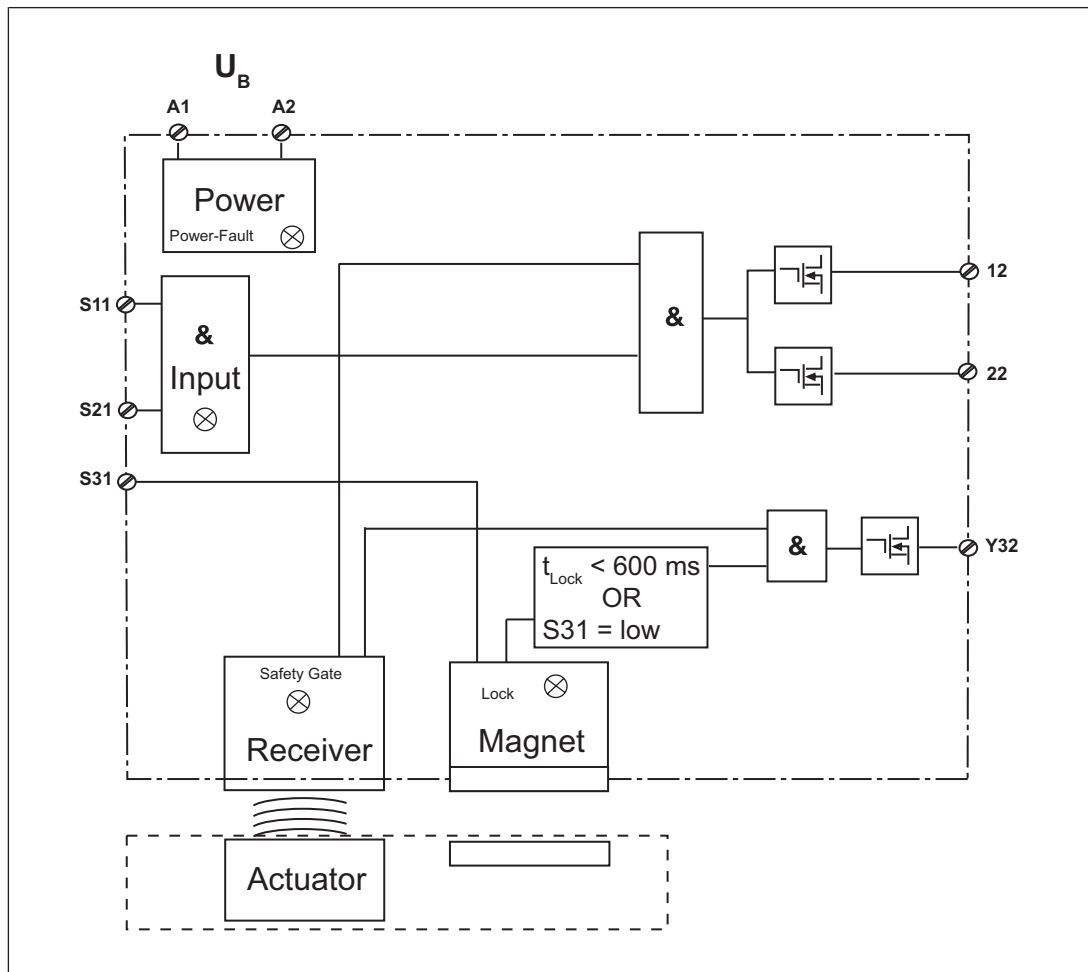

There is a high signal at safety outputs 12 and 22 if the following occur **simultaneously**:

- ▶ The actuator is within the response range (safety gate closed) and
- ▶ Inputs S11 and S21 are high.

Safety outputs 12 and 22 are low if **at least one** of the following conditions are met:

- ▶ The actuator is outside the response range or
- ▶ Inputs S11 and S21 are low.

Signal output Y32

The signal output Y32 receives a high signal if the actuator is within the response range (safety gate closed).

The high signal is maintained if the following conditions are met simultaneously

- ▶ [1] in the timing diagram
 - Actuator is within the response range **and**
 - There is a high signal at S31 **and**
 - The holding force of the locking magnets was achieved within $t_{Lock} = 600$ ms
- or

- ▶ [4] in the timing diagram
 - Actuator is within the response range **and**
 - There is a low signal at S31.

The signal output Y32 switches to low if

- ▶ The actuator leaves the response range (safety gate open) (see [3] in the timing diagram) **or**
- ▶ The holding force could not be achieved after $t_{Lock} = 600$ ms (see [2] in the timing diagram). In this case, the signal output can only switch back to high if
 - There is a low signal at input S31 for at least 500 ms **and**
 - a high signal is transmitted afterwards.

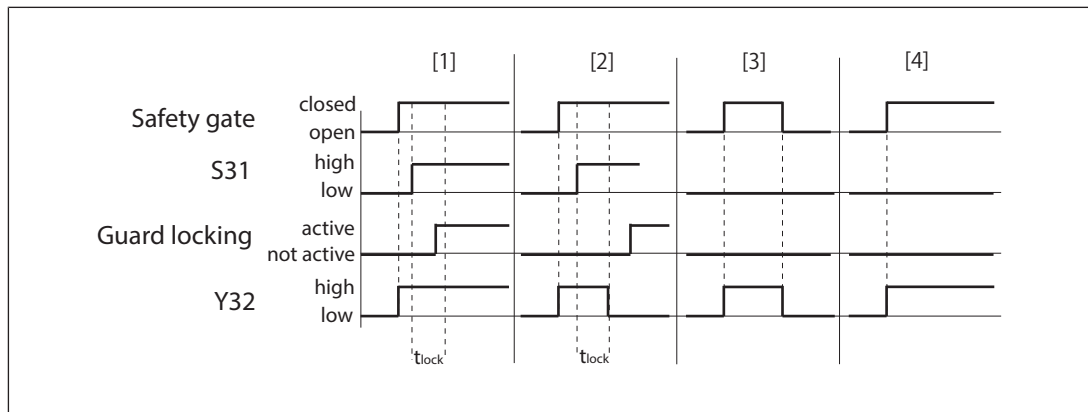

Feasibility monitoring for safety inputs S11 and S21

- ▶ If one safety input switches from high to low, while the other safety input remains high, an unequal status is displayed.
- ▶ If this safety input switches back from low to high, while the other safety input remains high, a feasibility error is displayed and a partial operation lock is triggered. The OSSDs are switched off during the partial operation lock.

A switch to a high signal will only lead to normal switch operation if both inputs had a low signal. From this moment on, the switch to high may occur (partial operation lock see [Error display](#) [23]).

Magnetic guard locking device and magnet monitoring

- ▶ The locking magnet is switched on if S31 (control command for magnetic guard locking) is high and the actuator is detected (safety gate closed).
- ▶ The holding force of the locking magnet is tested on power-up. If the magnet's holding force is not achieved after max. 600 ms, there will be no switch from low to high. The holding force will be tested a further 7 times.

These tests have no influence on the signal output. If the test is successful during any of these attempts, the gate is locked.

- ▶ After S31 switches to low, wait at least 500 ms until S31 is switched back to high. Also note the max. switching frequency (see Technical details: [System with normal actuator](#) [26], [System with free-moving actuator](#) [29], under electrical data).
- ▶ For physical reasons, a remanence (residual magnetism) remains after the locking magnet is switched off; this is dissipated the first time the sensor and actuator are separated.

- ▶ If the safety gate is in a locked condition and is opened by force, the safety outputs will shut down.

Lateral and vertical offset

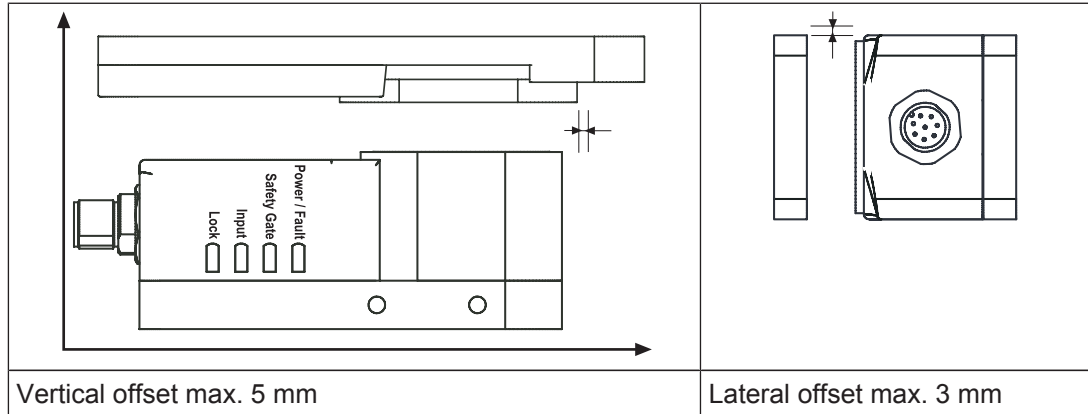

Wiring

Please note:

- ▶ You must comply with the specifications stated in the technical details (see Technical details: [System with normal actuator](#) [26], [System with free-moving actuator](#) [29], under electrical data, inputs and semiconductor outputs).
- ▶ The power supply must meet the regulations for extra low voltages with protective separation (SELV, PELV).
- ▶ The inputs and outputs of the safety switch must have a protective separation to voltages over 60 VDC.



INFORMATION

Only use safety relays with a 24 VDC supply voltage. Safety relays with universal power supply or in AC device versions have internal potential isolation and are not suitable as evaluation devices.

Guidelines for cable length

The max. cable length depends on the voltage drop at the sensor cables. The level of voltage drop is determined by the:

- ▶ Cable resistance
- ▶ Current of the device and the current load of the safety outputs 12 and 22

If the level of the supply voltage at the device connector falls below the minimum permitted value (see Technical details: [System with normal actuator](#) [26], [System with free-moving actuator](#) [29], under electrical data), the electromagnet is no longer activated reliably. The "Lock" LED registers an error when guard locking.

Possible remedies:

- ▶ Set the supply voltage constantly to the upper tolerance range (see Technical details: [System with normal actuator](#) [26], [System with free-moving actuator](#) [29], under electrical data)
- ▶ Select a higher cable cross section
- ▶ Reduce the load on the safety output, e.g. with an electrical evaluation device (PNOZ e1.1p, 5 mA/channel)

Recommended cable cross sections

Prerequisite:

- ▶ Supply voltage: 24 V
- ▶ Cable type: LiYY 8x0.25 mm² (79 Ohm/km) from Pilz

Max. load per safety output	100 mA	500 mA
Cable length	65 m	28 m

If cable lengths greater than those stated in the table are required, please contact Pilz.

Pin assignment

	8-pin M12 connector
--	---------------------

PIN	Function	Terminal designation	Cable colour (Pilz cable)
1	Input, channel 2	S21	White
2	+24 UB	A1	Brown
3	Output, channel1	12	Green
4	Output, channel2	22	Yellow
5	Signal output "Lock"	Y32	Grey
6	Input, channel 1	S11	Pink
7	0 V UB	A2	Blue
8	"Lock_Unlock"	S31	Red

The wire colour also applies for the cable available from Pilz as an accessory.

Connection to evaluation devices

Make sure that the selected evaluation device has the following properties:

- ▶ Dual-channel with feasibility monitoring
- ▶ OSSD signals are evaluated

Connection diagram, single connection

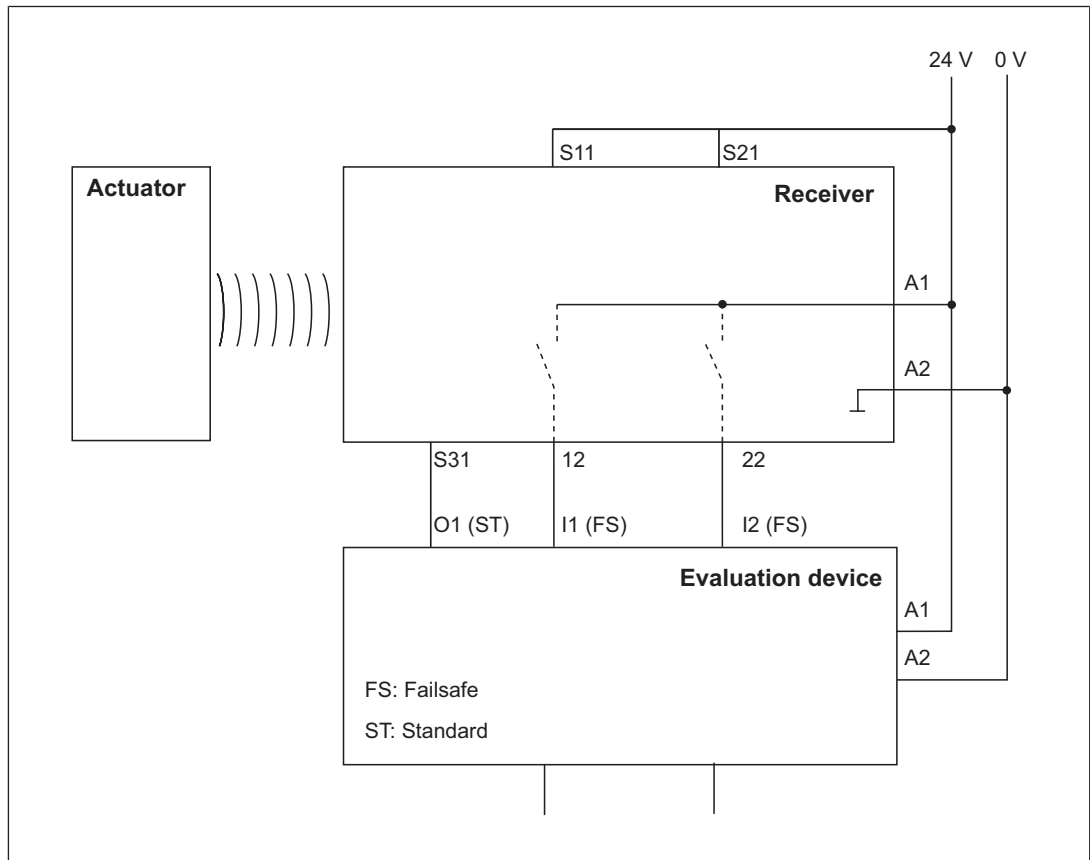

Connection diagram, series connection

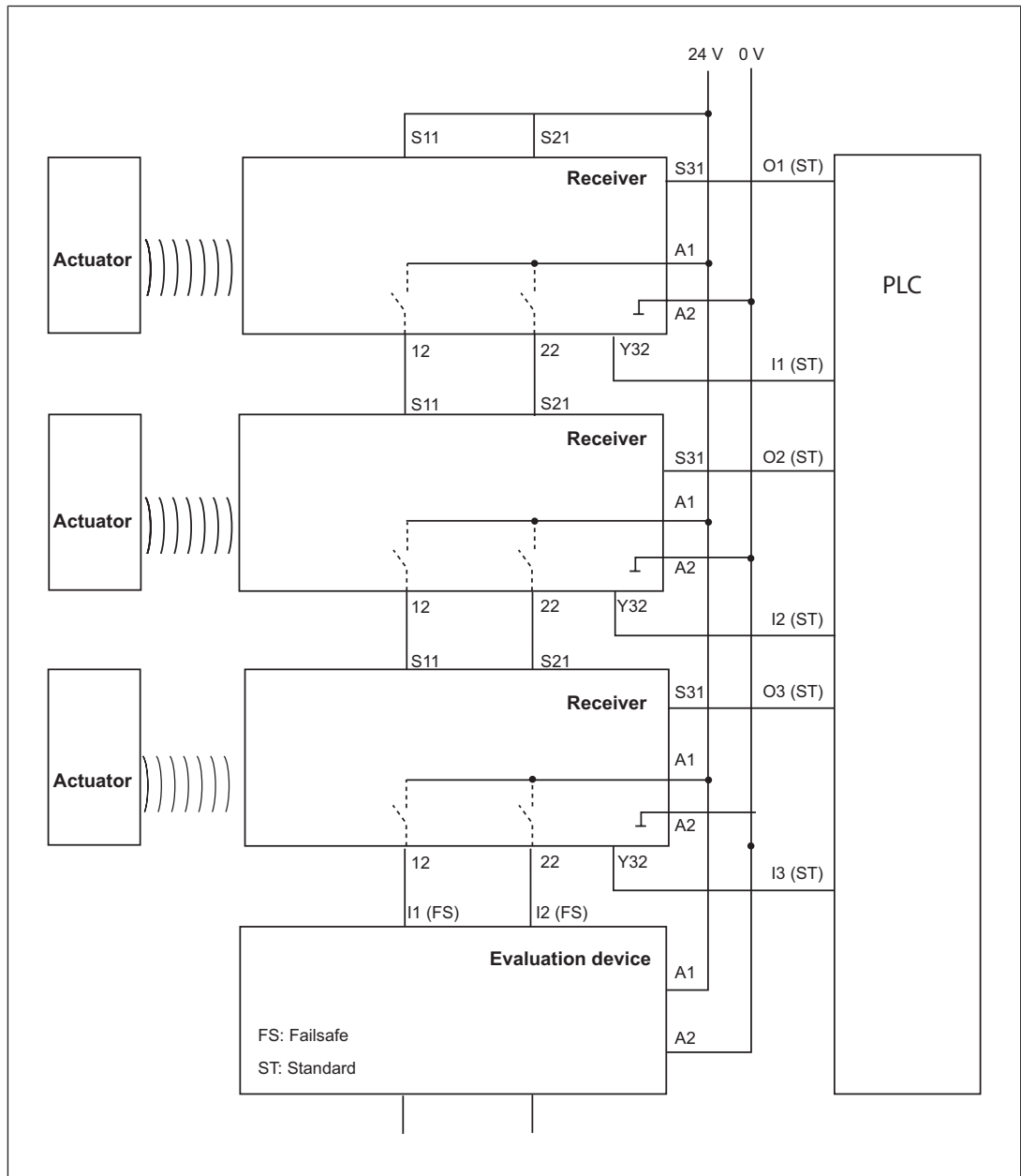

CAUTION!

Extension of delay-on de-energisation

When several (n) devices are connected in series, the delay-on de-energisation time adds with the number of interconnected safety switches. The may. delay-on de-energisation is composed of
 max. delay-on de-energisation actuator
 + (n-1) x max. delay-on de-energisation of the inputs
 + delay-on de-energisation of the evaluation device

**CAUTION!**

When several units are connected in series, the max. solenoid current increases in direct proportion to the number of interconnected safety switches (see [Technical details](#) [ 26], Max. inrush current impulse A1).

Connection to Pilz evaluation devices

The safety switch PSEN sl-0.5p 3.1/4.1/4.2 can be connected to Pilz evaluation devices, for example. Make sure that an evaluation device is selected that can evaluate OSSD signals through two channels.

Suitable Pilz evaluation devices are, for example:

- ▶ PNOZelog for safety gate monitoring
- ▶ PNOZpower for safety gate monitoring
- ▶ PNOZsigma for safety gate monitoring
- ▶ PNOZ X for safety gate monitoring
- ▶ PNOZmulti for safety gate monitoring
Configure the switch in the PNOZmulti Configurator with switch type 3.
- ▶ PSS for safety gate monitoring with standard function block SB064, SB066 or FS_Safety Gate

The correct connection to the respective evaluation device is described in the instructions for the evaluation device. Make sure that the connection is made in accordance with the specifications in the instructions for the selected evaluation device.

The connections to two evaluation devices are shown on the following pages, by way of example:

- ▶ PNOZ s3 and
- ▶ PNOZmulti

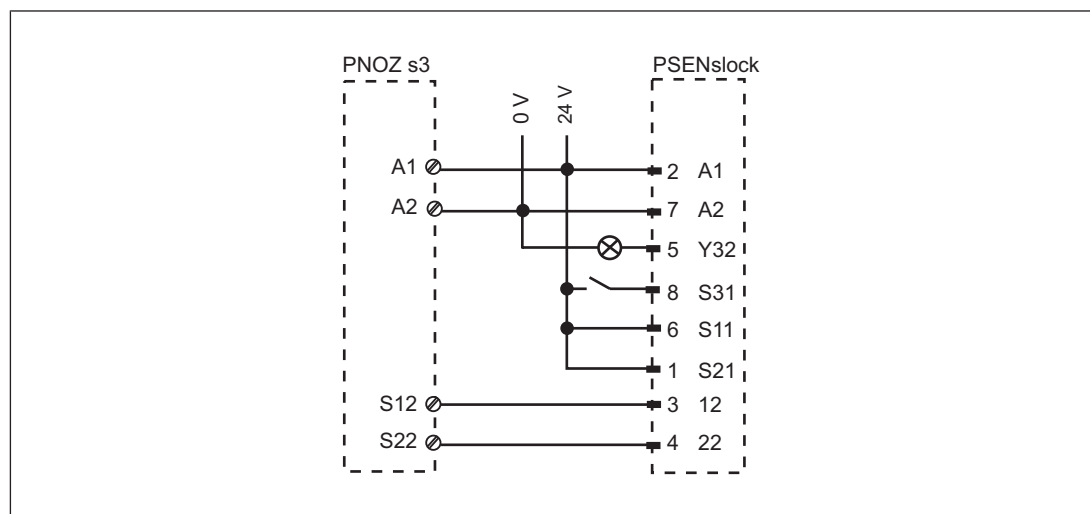
Connection example PNOZ s3

Connection example PNOZmulti

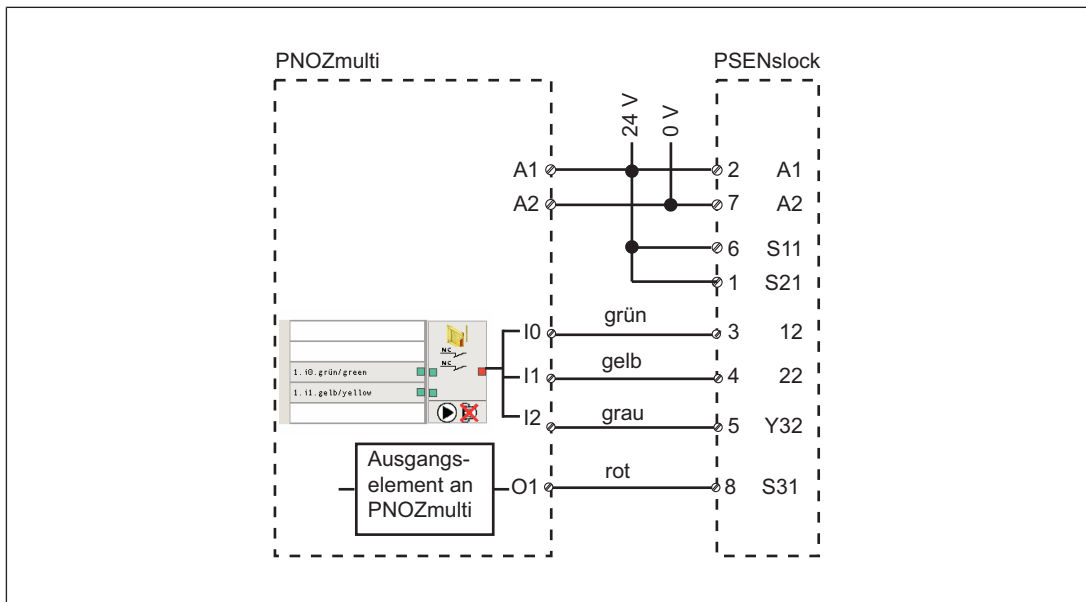

Legend:

I0	Input OSSD
I1	Input OSSD
I2	Signal input
O1	Lock/Unlock

Teaching in the actuator

PSEN si-0.5p 3.1

Any corresponding Pilz actuator (see Technical details: [System with normal actuator](#) [26], [System with free-moving actuator](#) [29], under mechanical data) is detected as soon as it is brought into the response range.

PSEN si-0.5p 4.1

Teaching in the actuator for the first time:

The first corresponding actuator to be detected by the safety switch (see Technical details: [System with normal actuator](#) [26], [System with free-moving actuator](#) [29], under mechanical data) is automatically taught in as soon as it is brought into the response range.

To teach in a new actuator:

- ▶ The actuator that is to be taught in must be brought into the safety switch's response range as the only transponder. As soon as the actuator is detected, the "Safety Gate" LED switches to a yellow flashing light.
- ▶ After 20 s has elapsed, the "Safety Gate" LED switches to quick yellow flashes. Trigger a system reset in the next 120 s by interrupting the power supply.
- ▶ When the device is switched back on, the learning procedure is complete and the number of permitted additional learning procedures is reduced by 1.

- ▶ A maximum of 8 learning procedures are possible.

**NOTICE**

The actuator must not be removed during the learning procedure.

**INFORMATION**

This actuator cannot be retaught on the same safety switch.

PSEN sl-0.5p 4.2

The first corresponding actuator to be detected by the safety switch (see Technical details: [System with normal actuator](#) [26], [System with free-moving actuator](#) [29], under mechanical data) is automatically taught in as soon as it is brought into the response range.

**NOTICE**

No other actuator may be taught in once this actuator has been taught.

Installation

- ▶ When installing make sure you comply with the requirements of DIN EN 1088.
- ▶ The safety gate system can be installed on left or right-hinged swing gates or on sliding gates.

**WARNING!**

Potential loss of safety function due to gross manipulation
Depending on the application, serious injury or death may result.

Use appropriate installation measures to prevent

- The wiring being modified.
- A short circuit being generated on the connector.
- The possibility of using a second actuator to open the safety gate.

- ▶ The safety switch and actuator should be installed opposite each other in parallel.
- ▶ The actuator should be secured permanently using safety screws or rivets.

**CAUTION!**

The unit's properties may be affected if installed in an environment containing electrically or magnetically conductive material. Please check the operating distances and the assured release distance.

**INFORMATION**

Mounting brackets are available as [accessories](#) [ 33].

Note regarding the free-moving actuator PSEN sl-0.5fm

The free-moving actuators PSEN sl-0.5fm are fitted with a movable metal plate. For this reason, a recess must be provided in the mounting surface for the screw connection.

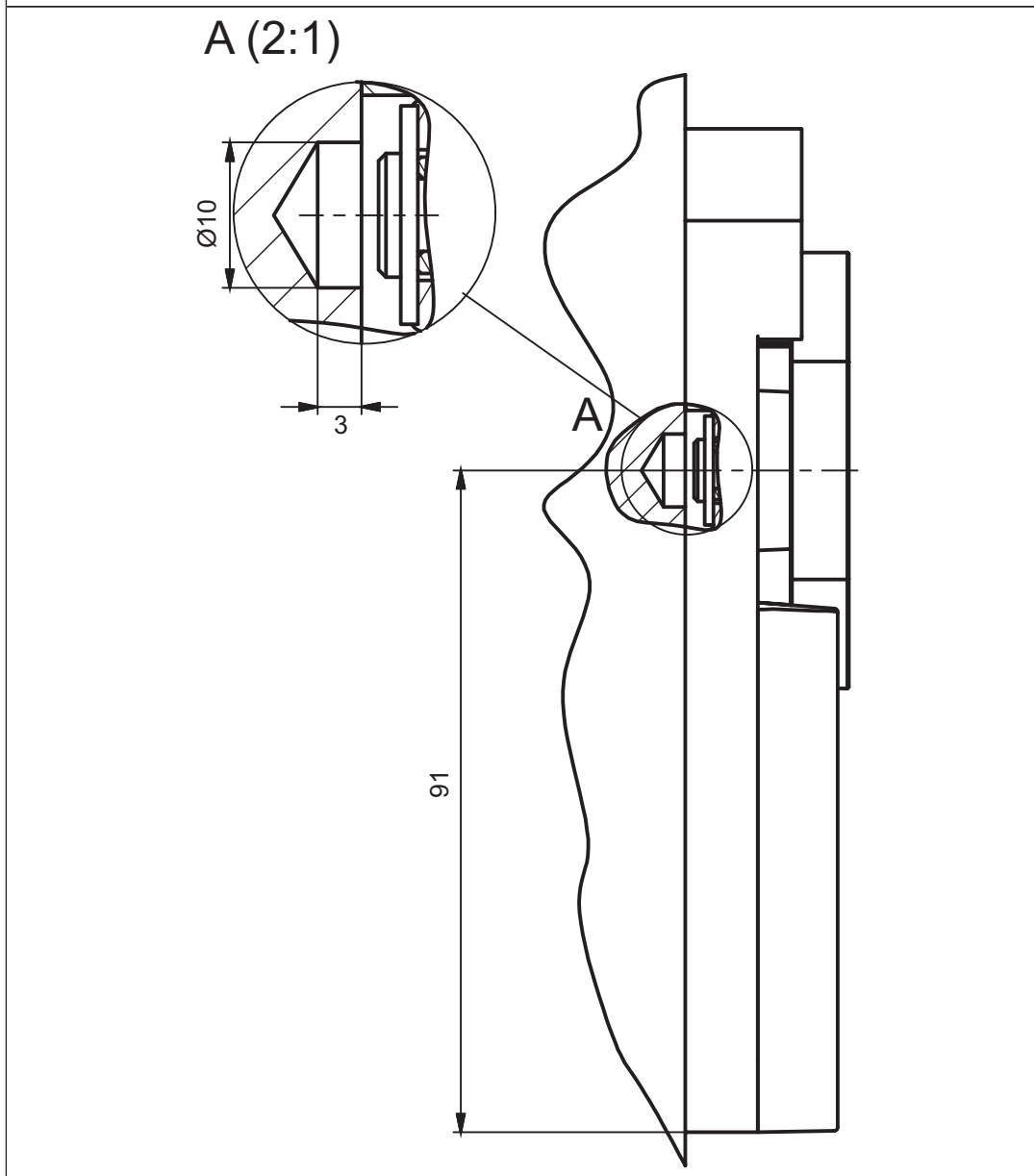
**WARNING!**

Risk of death and serious injury by reaching into the danger zone!

The actuators enable a warped gate to be closed. A gap may occur on the gate as a result. Make sure that the gap remains small enough to exclude the possibility of reaching into the danger zone.

Installing on a swing gate

Align the actuator flush with the edge of the gate at the height required and tighten the screws.

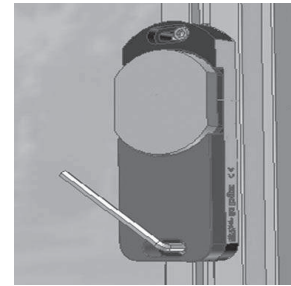

Close gate.

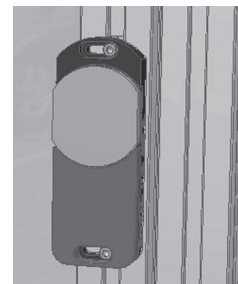

Align the mounting bracket flush with the sensor and tighten the screws.



Align the sensor and mounting bracket with the actuator and tighten the screws.

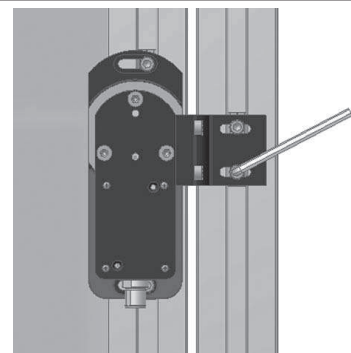

Installing on a sliding gate

Align the actuator mounting bracket flush with the sliding gate and tighten the screws.

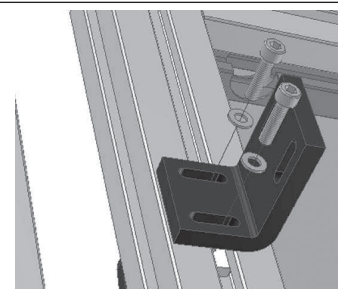

Install the actuator at the height required.

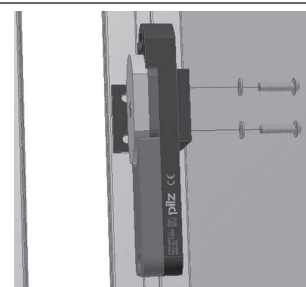

Align the sensor mounting bracket flush with the frame and fasten with screws.
Important: Do not tighten the screws.

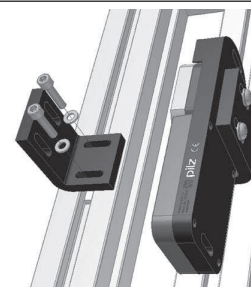

Fix sensor upright with a screw (a), close gate.

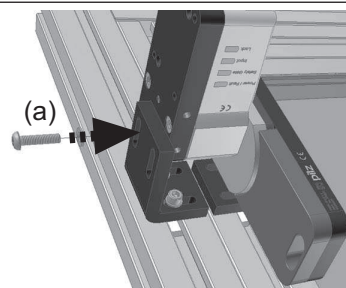

Align mounting brackets, press firmly together and tighten screw (b).

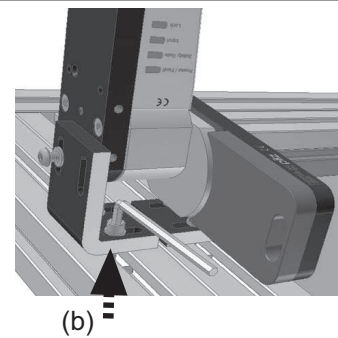

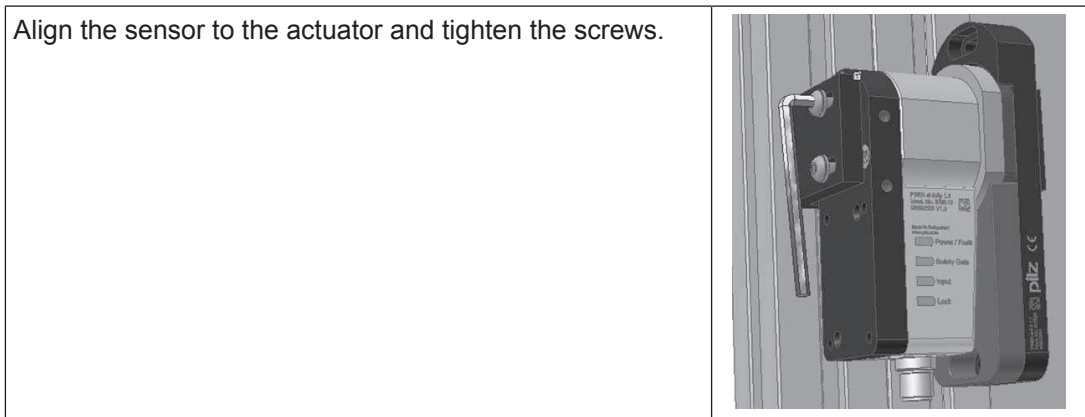
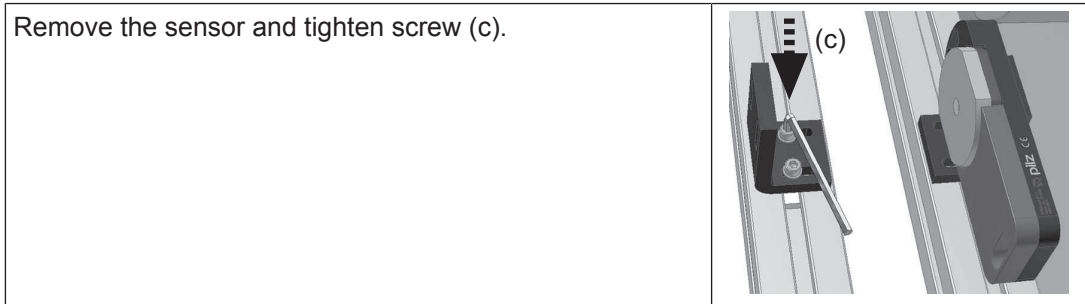

Adjustment

- ▶ The stated operating distances (see Technical details: [System with normal actuator](#) [26], [System with free-moving actuator](#) [29], under mechanical data) only apply when the safety switch and actuator are installed facing each other in parallel. Operating distances may deviate if other arrangements are used.
- ▶ Note the maximum permitted lateral and vertical offset (see [Lateral and vertical offset](#) [11]).

Operation

Check the function of the safety switch before commissioning.

Any deviations from the properties and functions described in these operating instructions can lead to hazardous situations.



CAUTION!

Contaminated surfaces can reduce the holding force of the electromagnet.
Make sure that the contact surfaces are clean.

Status indicators:

- ▶ "Power/Fault" LED lights up green: The unit is ready for operation
- ▶ "Safety Gate" LED lights up yellow: Actuator is within the response range
- ▶ "Lock" LED lights up green: Magnetic guard locking device active and signal output Y32 is high
- ▶ "Input" LED lights up yellow: There is a HIGH signal at the inputs

Error display through periodic flashing:

- ▶ "Input" LED lights up yellow: the signal switches from high to low at one input, while a high signal remains on the other input (**partial operation**).
Remedy: Open both channels of the input circuit.
- ▶ "Power/Fault" LED lights up red: Error message
Flashing codes for fault diagnostics are output to the "Safety Gate" or "Input" LED (see Error display through flashing codes).
Remedy: Rectify fault and interrupt power supply.
- ▶ "Lock" LED lights up red: Guard locking request is present, but guard locking has not taken place within 600 ms or the safety gate was opened by force.
This behaviour occurs, for example, when the safety gate is open or the actuator is not within the response range (even temporarily) or the holding force is too low.
Remedy: Rectify the cause (e.g. close safety gate), switch off S31 and then switch it back on again after at least 500 ms.

Please note the different times for

- ▶ The switch-on delay after UB is applied.

Error display through flashing codes

The "Safety Gate" and "Input" LEDs send flash signals; an error code can be established from the number and sequence. The "Power/Fault" LED illuminates red.

Each error code is indicated by three short flashes of the "Input" or "Safety Gate" LED. After a longer pause, the LED will then flash at one second intervals. The number of LED flashes corresponds to a digit in the error code. The error code can consist of up to 3 digits. The digits are separated by a longer period without flashing. The entire sequence is constantly repeated.

Number of flashes	1 2 3 4 5 6 7 8 9 10 11 12 13 14 15 16
Decimal error code	1 2 3 4 5 6 7 8 9 10 11 12 13 14 15 0

Example:

Error code 1,4,1:

Flash frequency of the "Safety Gate" or "Input" LED

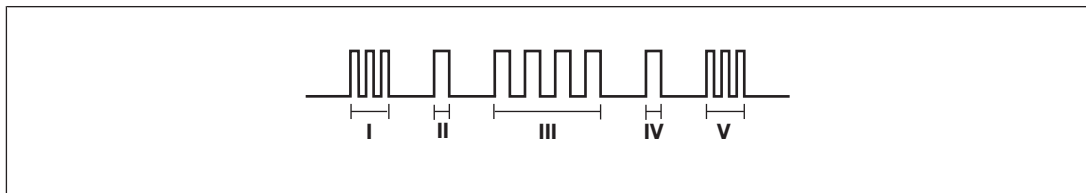

Meaning of flash frequency:

	Flash frequency	Meaning
I	3 times, short	Code for error message
II	Once, for one second each	Code for 1st digit
III	4 times, for one second each	Code for 2nd digit
IV	Once, for one second each	Code for 3rd digit
V	3 times, short	Code for error message repeated

Table of error codes

Error code Decimal	Number of flashes	Description	Remedy
1.4.1	3x short – 1x long – 4x long – 1x long – 3x short	Wiring error	Rectify wiring error
1.12	3x short – 1x long – 12x long – 3x short	Wiring error	Rectify wiring error
1.6.3	3x short – 1x long – 6x long – 3x long – 3x short	Wiring error	Rectify wiring error
1.13	3x short – 1x long – 12x long – 3x short	Wiring error	Rectify wiring error
1.6.4	3x short – 1x long – 6x long – 4x long – 3x short	Wiring error	Rectify wiring error
14	3x short – 14x long – 3x short	Wiring error	Rectify wiring error
15	3x short – 15x long – 3x short	Wiring error	Rectify wiring error

Other flashing codes signal an internal error. Remedy: Change device.

Dimensions in mm

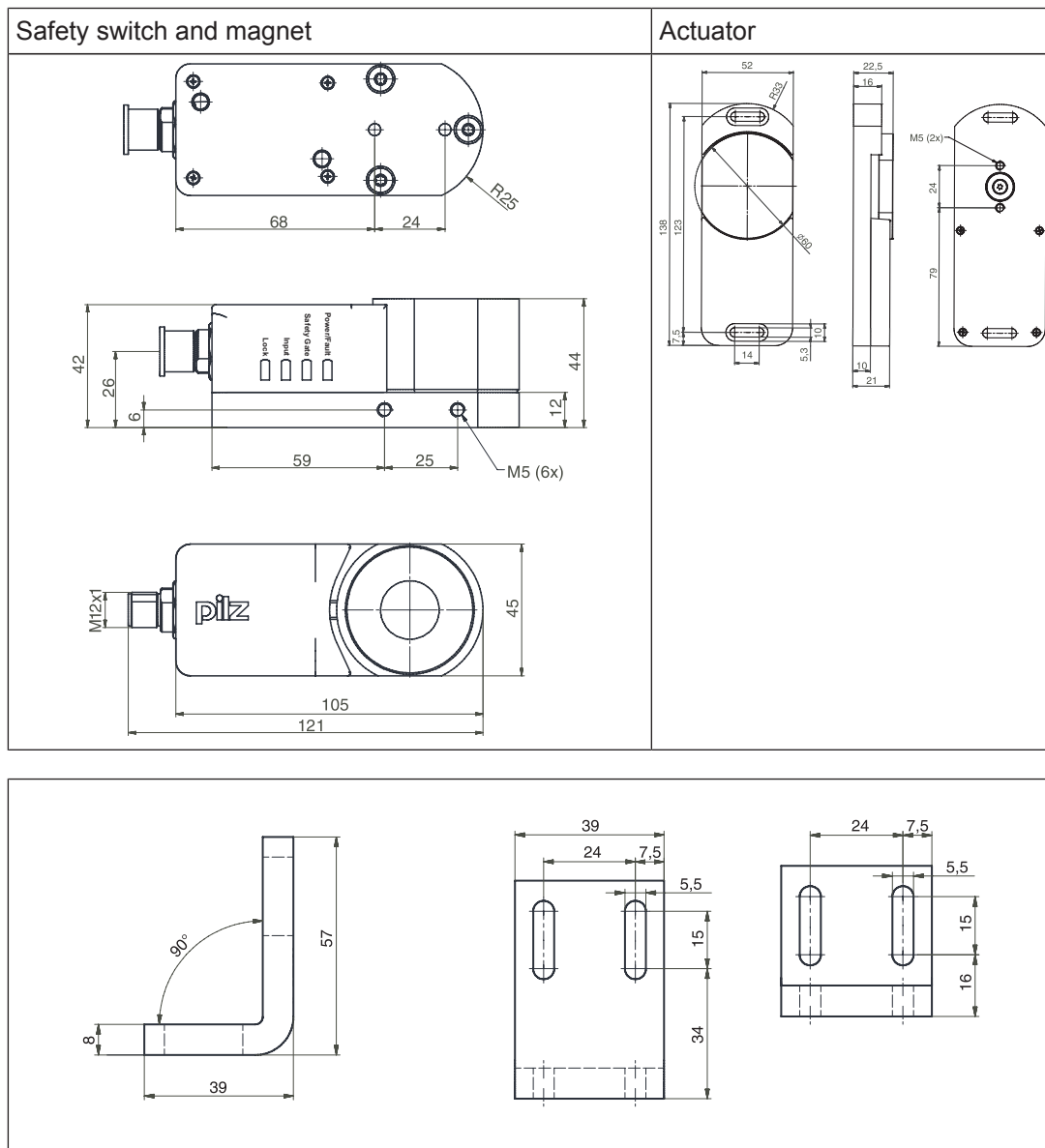

Fig.: Mounting bracket for sliding gate (see [Accessories](#) [33])

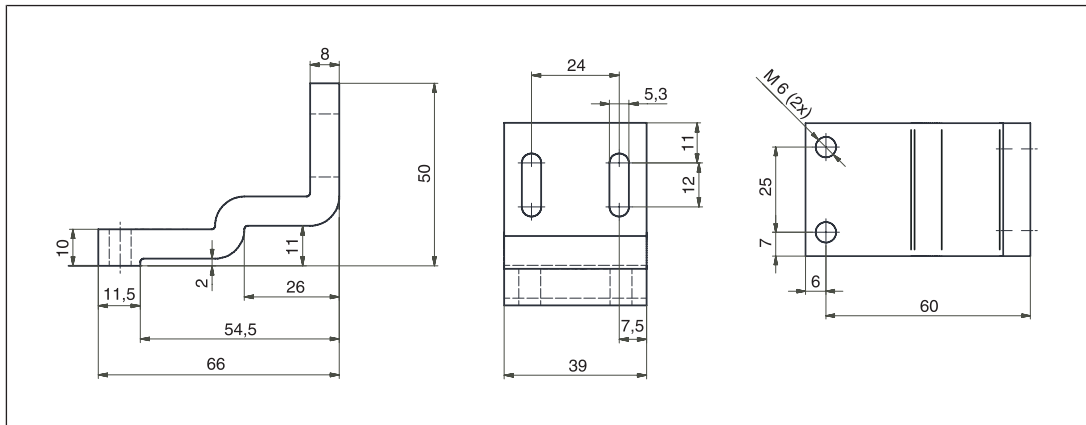

Fig.: Mounting bracket for swing gate (see [Accessories](#) [33])

Technical Details Order No. 570570-570572

General	570570	570571	570572
Approvals	CE, EAC (Eurasian), TÜV, cULus Listed	CE, EAC (Eurasian), TÜV, cULus Listed	CE, EAC (Eurasian), TÜV, cULus Listed
Sensor's mode of operation	Transponder	Transponder	Transponder
Classification in accordance with EN 60947-5-3	PDF-M	PDF-M	PDF-M
Electrical data	570570	570571	570572
Supply voltage			
Voltage	24,0 V	24,0 V	24,0 V
Kind	DC	DC	DC
Voltage tolerance	-15 %/+10 %	-15 %/+10 %	-15 %/+10 %
Output of external power supply (DC)	4,8 W	4,8 W	4,8 W
Max. inrush current at UB	0,60 A	0,60 A	0,60 A
Max. switching frequency	1 Hz	1 Hz	1 Hz
Max. cable capacitance at the safety outputs			
No-load, PNOZ with relay contacts	40 nF	40 nF	40 nF
PNOZmulti, PNOZelog, PSS	70 nF	70 nF	70 nF
Max. inrush current impulse			
Current pulse, A1	9,90 A	9,90 A	9,90 A
Pulse duration, A1	0,0020 ms	0,0020 ms	0,0020 ms
Inputs	570570	570571	570572
Number	2	2	2
Voltage at inputs	24 V DC	24 V DC	24 V DC
Input current range	5,0 mA	5,0 mA	5,0 mA
Semiconductor outputs	570570	570571	570572
OSSD safety outputs	2	2	2

Semiconductor outputs	570570	570571	570572
Signal outputs	1	1	1
Switching current per output	500 mA	500 mA	500 mA
Breaking capacity per output	12,0 W	12,0 W	12,0 W
Residual current at "0" signal	0,25 mA	0,25 mA	0,25 mA
Short circuit-proof	Yes	Yes	Yes
Relay outputs	570570	570571	570572
Number of safety outputs	2	2	2
Times	570570	570571	570572
Test pulse duration, safety outputs	450 µs	450 µs	450 µs
Switch-on delay			
after UB is applied	1,6 s	1,6 s	1,6 s
Inputs typ.	20 ms	20 ms	20 ms
Inputs max.	35 ms	35 ms	35 ms
Actuator typ.	500 ms	500 ms	500 ms
Delay-on de-energisation			
Inputs typ.	20 ms	20 ms	20 ms
Inputs max.	35 ms	35 ms	35 ms
Actuator typ.	25 ms	25 ms	25 ms
Actuator max.	260 ms	260 ms	260 ms
Supply interruption before de-energisation in the input circuit	17,0 ms	17,0 ms	17,0 ms
Simultaneity, channel 1 and 2	∞	∞	∞
Environmental data	570570	570571	570572
Metal surface temperature	60 °C	60 °C	60 °C
Ambient temperature			
In accordance with the standard	EN 60068-2-14	EN 60068-2-14	EN 60068-2-14
Temperature range	-25 - 55 °C	-25 - 55 °C	-25 - 55 °C
Storage temperature			
In accordance with the standard	EN 60068-2-1/-2	EN 60068-2-1/-2	EN 60068-2-1/-2
Temperature range	-25 - 70 °C	-25 - 70 °C	-25 - 70 °C
Climatic suitability			
In accordance with the standard	EN 60068-2-78	EN 60068-2-78	EN 60068-2-78
Humidity	93 % r. h. at 40 °C	93 % r. h. at 40 °C	93 % r. h. at 40 °C
EMC	EN 55011: class A, EN 60947-5-3, EN 62061	EN 55011: class A, EN 60947-5-3, EN 62061	EN 55011: class A, EN 60947-5-3, EN 62061

Environmental data	570570	570571	570572
Vibration			
In accordance with the standard	EN 60947-5-2	EN 60947-5-2	EN 60947-5-2
Frequency	10,0 - 55,0 Hz	10,0 - 55,0 Hz	10,0 - 55,0 Hz
Amplitude	1,00 mm	1,00 mm	1,00 mm
Shock stress			
In accordance with the standard	EN 60068-2-27	EN 60068-2-27	EN 60068-2-27
Acceleration	30 g	30 g	30 g
Duration	11 ms	11 ms	11 ms
In accordance with the standard	EN 60068-2-29	EN 60068-2-29	EN 60068-2-29
Acceleration	10 g	10 g	10 g
Duration	16 ms	16 ms	16 ms
Airgap creepage			
Overvoltage category	III	III	III
Pollution degree	3	3	3
Rated insulation voltage	75 V	75 V	75 V
Rated impulse withstand voltage	1,00 kV	1,00 kV	1,00 kV
Protection type			
Housing	IP67	IP67	IP67
Mechanical data	570570	570571	570572
Magnetic holding force on	500 N	500 N	500 N
Magnetic holding force off	30 N	30 N	30 N
Max. vertical offset	5 mm	5 mm	5 mm
Max. lateral offset	3 mm	3 mm	3 mm
Max. angular offset	2,5 deg	2,5 deg	2,5 deg
Actuator 1	PSEN sl-0.5 1.1	PSEN sl-0.5 2.1	PSEN sl-0.5 2.1
Operating distances			
Assured operating distance S_{ao}	1,0 mm	1,0 mm	1,0 mm
Typical operating distance S_o	2,0 mm	2,0 mm	2,0 mm
Assured release distance S_{ar}	15,0 mm	15,0 mm	15,0 mm
Change of operating distance with temperature changes	+0,01mm/°C	+0,01mm/°C	+0,01mm/°C
Typ. hysteresis	0,7 mm	0,7 mm	0,7 mm
Min. distance between safety switches	30 mm	30 mm	30 mm
Connection type	M12, 8-pin male connector	M12, 8-pin male connector	M12, 8-pin male connector
Cable	LiYY 8 x 0.25 mm²	LiYY 8 x 0.25 mm²	LiYY 8 x 0.25 mm²

Mechanical data	570570	570571	570572
Material			
Top	PBT	PBT	PBT
Anchor plate	Steel, nickel-plated	Steel, nickel-plated	Steel, nickel-plated
Base plate	Anticorodal, hard anodised	Anticorodal, hard anodised	Anticorodal, hard anodised
Actuator	Anticorodal, hard anodised	Anticorodal, hard anodised	Anticorodal, hard anodised
Dimensions			
Height	122,0 mm	122,0 mm	122,0 mm
Width	45,0 mm	45,0 mm	45,0 mm
Depth	44,0 mm	44,0 mm	44,0 mm
Actuator dimensions			
Height	138,0 mm	138,0 mm	138,0 mm
Width	52,0 mm	52,0 mm	52,0 mm
Depth	23,0 mm	23,0 mm	23,0 mm
Weight of safety switch	570 g	570 g	570 g
Weight of actuator	371 g	371 g	371 g
Weight	941 g	941 g	941 g

Technical Details Order No. 570573-570575

General	570573	570574	570575
Approvals	CE, EAC (Eurasian), TÜV, cULus Listed	CE, EAC (Eurasian), TÜV, cULus Listed	CE, EAC (Eurasian), TÜV, cULus Listed
Sensor's mode of operation	Transponder	Transponder	Transponder
Classification in accordance with EN 60947-5-3	PDF-M	PDF-M	PDF-M
Electrical data	570573	570574	570575
Supply voltage			
Voltage	24,0 V	24,0 V	24,0 V
Kind	DC	DC	DC
Voltage tolerance	-15 %/+10 %	-15 %/+10 %	-15 %/+10 %
Output of external power supply (DC)	4,8 W	4,8 W	4,8 W
Max. inrush current at UB	0,60 A	0,60 A	0,60 A
Max. switching frequency	1 Hz	1 Hz	1 Hz
Max. cable capacitance at the safety outputs			
No-load, PNOZ with relay contacts	40 nF	40 nF	40 nF
PNOZmulti, PNOZelog, PSS	70 nF	70 nF	70 nF
Max. inrush current impulse			
Current pulse, A1	9,90 A	9,90 A	9,90 A
Pulse duration, A1	0,0020 ms	0,0020 ms	0,0020 ms

Inputs	570573	570574	570575
Number	2	2	2
Voltage at inputs	24 V DC	24 V DC	24 V DC
Input current range	5,0 mA	5,0 mA	5,0 mA
Semiconductor outputs	570573	570574	570575
OSSD safety outputs	2	2	2
Signal outputs	1	1	1
Switching current per output	500 mA	500 mA	500 mA
Breaking capacity per output	12,0 W	12,0 W	12,0 W
Residual current at "0" signal	0,25 mA	0,25 mA	0,25 mA
Short circuit-proof	Yes	Yes	Yes
Relay outputs	570573	570574	570575
Number of safety outputs	2	2	2
Times	570573	570574	570575
Test pulse duration, safety outputs	450 µs	450 µs	450 µs
Switch-on delay			
after UB is applied	1,6 s	1,6 s	1,6 s
Inputs typ.	20 ms	20 ms	20 ms
Inputs max.	35 ms	35 ms	35 ms
Actuator typ.	500 ms	500 ms	500 ms
Delay-on de-energisation			
Inputs typ.	20 ms	20 ms	20 ms
Inputs max.	35 ms	35 ms	35 ms
Actuator typ.	25 ms	25 ms	25 ms
Actuator max.	260 ms	260 ms	260 ms
Supply interruption before de-energisation in the input circuit	17,0 ms	17,0 ms	17,0 ms
Simultaneity, channel 1 and 2	∞	∞	∞
Environmental data	570573	570574	570575
Metal surface temperature	60 °C	60 °C	60 °C
Ambient temperature			
In accordance with the standard	EN 60068-2-14	EN 60068-2-14	EN 60068-2-14
Temperature range	-25 - 55 °C	-25 - 55 °C	-25 - 55 °C
Storage temperature			
In accordance with the standard	EN 60068-2-1/-2	EN 60068-2-1/-2	EN 60068-2-1/-2
Temperature range	-25 - 70 °C	-25 - 70 °C	-25 - 70 °C
Climatic suitability			
In accordance with the standard	EN 60068-2-78	EN 60068-2-78	EN 60068-2-78
Humidity	93 % r. h. at 40 °C	93 % r. h. at 40 °C	93 % r. h. at 40 °C

Environmental data	570573	570574	570575
EMC	EN 55011: class A, EN 60947-5-3, EN 62061	EN 55011: class A, EN 60947-5-3, EN 62061	EN 55011: class A, EN 60947-5-3, EN 62061
Vibration			
In accordance with the standard	EN 60947-5-2	EN 60947-5-2	EN 60947-5-2
Frequency	10,0 - 55,0 Hz	10,0 - 55,0 Hz	10,0 - 55,0 Hz
Amplitude	1,00 mm	1,00 mm	1,00 mm
Shock stress			
In accordance with the standard	EN 60068-2-27	EN 60068-2-27	EN 60068-2-27
Acceleration	30 g	30 g	30 g
Duration	11 ms	11 ms	11 ms
In accordance with the standard	EN 60068-2-29	EN 60068-2-29	EN 60068-2-29
Acceleration	10 g	10 g	10 g
Duration	16 ms	16 ms	16 ms
Airgap creepage			
Overvoltage category	III	III	III
Pollution degree	3	3	3
Rated insulation voltage	75 V	75 V	75 V
Rated impulse withstand voltage	1,00 kV	1,00 kV	1,00 kV
Protection type			
Housing	IP67	IP67	IP67
Mechanical data	570573	570574	570575
Magnetic holding force on	500 N	500 N	500 N
Magnetic holding force off	30 N	30 N	30 N
Max. vertical offset	5 mm	5 mm	5 mm
Max. lateral offset	3 mm	3 mm	3 mm
Max. angular offset	2,5 deg	2,5 deg	2,5 deg
Actuator 1	PSEN sl-0.5fm 1.1	PSEN sl-0.5fm 2.1	PSEN sl-0.5fm 2.1
Operating distances			
Assured operating distance S_{ao}	1,0 mm	1,0 mm	1,0 mm
Typical operating distance S_o	2,0 mm	2,0 mm	2,0 mm
Assured release distance S_{ar}	15,0 mm	15,0 mm	15,0 mm
Change of operating distance with temperature changes	+0,01mm/°C	+0,01mm/°C	+0,01mm/°C
Typ. hysteresis	0,7 mm	0,7 mm	0,7 mm
Min. distance between safety switches	30 mm	30 mm	30 mm
Connection type	M12, 8-pin male connector	M12, 8-pin male connector	M12, 8-pin male connector
Cable	LiYY 8 x 0.25 mm ²	LiYY 8 x 0.25 mm ²	LiYY 8 x 0.25 mm ²

Mechanical data	570573	570574	570575
Material			
Top	PBT	PBT	PBT
Anchor plate	Steel, nickel-plated	Steel, nickel-plated	Steel, nickel-plated
Base plate	Anticorodal, hard anodised	Anticorodal, hard anodised	Anticorodal, hard anodised
Actuator	Anticorodal, hard anodised	Anticorodal, hard anodised	Anticorodal, hard anodised
Dimensions			
Height	122,0 mm	122,0 mm	122,0 mm
Width	45,0 mm	45,0 mm	45,0 mm
Depth	44,0 mm	44,0 mm	44,0 mm
Actuator dimensions			
Height	138,0 mm	138,0 mm	138,0 mm
Width	52,0 mm	52,0 mm	52,0 mm
Depth	23,0 mm	23,0 mm	23,0 mm
Weight of safety switch	570 g	570 g	570 g
Weight of actuator	362 g	362 g	362 g
Weight	932 g	932 g	932 g

Status of the applied standards

- ▶ EN ISO 13849-1:2008
- ▶ EN ISO 13849-2:2008
- ▶ EN 62061:2005
- ▶ EN 60947-5-3:2005
- ▶ EN 60204-1:2006
- ▶ EN 1088:2008
- ▶ ISO 14119:2007

For undated standards that are not listed here, the latest editions valid on 2014-12 shall apply.

Safety characteristic data

Operating mode	EN ISO 13849-1: 2008	EN ISO 13849-1: 2008	EN 62061: 2005	EN 62061: 2005	IEC 61511: 2005	IEC 61511: 2005	EN ISO 13849-1: 2008
	PL	Category	SIL CL	PFH_D [1/h]	SIL	PFD	T_M [year]
2-ch. OSSD	PL e	Cat. 4	SIL CL 3	3,29E-09	SIL 3	1,72E-04	20

All the units used within a safety function must be considered when calculating the safety characteristic data.

**INFORMATION**

A safety function's SIL/PL values are **not** identical to the SIL/PL values of the units that are used and may be different. We recommend that you use the PASCAL software tool to calculate the safety function's SIL/PL values.

Order reference**Safety gate system**

Product type	Features	Connection type	Order no.
PSEN sl-0.5p 3.1 / PSEN sl-0.5 1 unit	Safety gate system, coded	M12, 8-pin connector	570 570
PSEN sl-0.5p 4.1 / PSEN sl-0.5 1 unit	Safety gate system, fully coded	M12, 8-pin connector	570 571
PSEN sl-0.5p 4.2 / PSEN sl-0.5 1 unit	Safety gate system, uniquely coded	M12, 8-pin connector	570 572
PSEN sl-0.5p 3.1 / PSEN sl-0.5fm 1 unit	Safety gate system, coded, with free-moving actuator	M12, 8-pin connector	570 573
PSEN sl-0.5p 4.1 / PSEN sl-0.5fm 1 unit	Safety gate system, fully coded, with free-moving actuator	M12, 8-pin connector	570 574
PSEN sl-0.5p 4.2 / PSEN sl 0.5fm 1 unit	Safety gate system, uniquely coded, with free-moving actuator	M12, 8-pin connector	570 575

Accessories

Product type	Features	Order no.
PSEN sl bracket swing door	Mounting bracket for swing gates and folding gates	570 550
PSEN sl bracket sliding door	Mounting bracket for sliding gates	570 551

EC declaration of conformity

This product/these products meet the requirements of the directive 2006/42/EC for machinery of the European Parliament and of the Council. The complete EC Declaration of Conformity is available on the Internet at www.pilz.com/downloads.

Representative: Norbert Fröhlich, Pilz GmbH & Co. KG, Felix-Wankel-Str. 2, 73760 Ostfildern, Germany

► Support

Technical support is available from Pilz round the clock.

Americas

Brazil
+55 11 97569-2804
Canada
+1 888-315-PILZ (315-7459)
Mexico
+52 55 5572 1300
USA (toll-free)
+1 877-PILZUSA (745-9872)

Asia

China
+86 21 60880878-216
Japan
+81 45 471-2281
South Korea
+82 31 450 0680

Australia

+61 3 95446300

Europe

Austria
+43 1 7986263-0
Belgium, Luxembourg
+32 9 3217575
France
+33 3 88104000
Germany
+49 711 3409-444
Ireland
+353 21 4804983
Italy
+39 0362 1826711

Scandinavia

+45 74436332

Spain

+34 938497433

Switzerland

+41 62 88979-30

The Netherlands

+31 347 320477

Turkey

+90 216 5775552

United Kingdom

+44 1536 462203

You can reach our international hotline on:

+49 711 3409-444
support@pilz.com

Pilz develops environmentally-friendly products using ecological materials and energy-saving technologies. Offices and production facilities are ecologically designed, environmentally-aware and energy-saving. So Pilz offers sustainability, plus the security of using energy-efficient products and environmentally-friendly solutions.

The 4-fold safety of automation

COMPONENTS
SYSTEMS
SERVICES

Technical Ecological
Personal Economical

Energy saving by Pilz

BLUECOMPETENCE

Alliance Member

Partner of the Engineering Industry Sustainability Initiative



CMSE, InduraNET p, PAS4000, PAScal, PASconfig, Pilz, PIT, PLID, PMCPrimo, PMCProtego, PMCTendo, PMD, PMI, PNOZ, Primo, PSEN, PSS, PVIS, Safety SafetyYE, SafetyNET p, the spirit of safety, are registered and protected trademarks of Pilz GmbH & Co. KG in some countries. We would point out that product features may vary from the details stated in this document, depending on the status at the time of publication and the scope of the equipment. We accept no responsibility for the validity, accuracy and entirety of the text and graphics presented in this information. Please contact our Technical Support if you have any questions.

1003388-EN-02, 2015-02 Printed in Germany
© Pilz GmbH & Co. KG, 2011

Pilz GmbH & Co. KG
Felix-Wankel-Straße 2
73760 Ostfildern, Germany
Tel.: +49 711 3409-0
Fax: +49 711 3409-133
info@pilz.com
www.pilz.com

pilz
the spirit of safety