

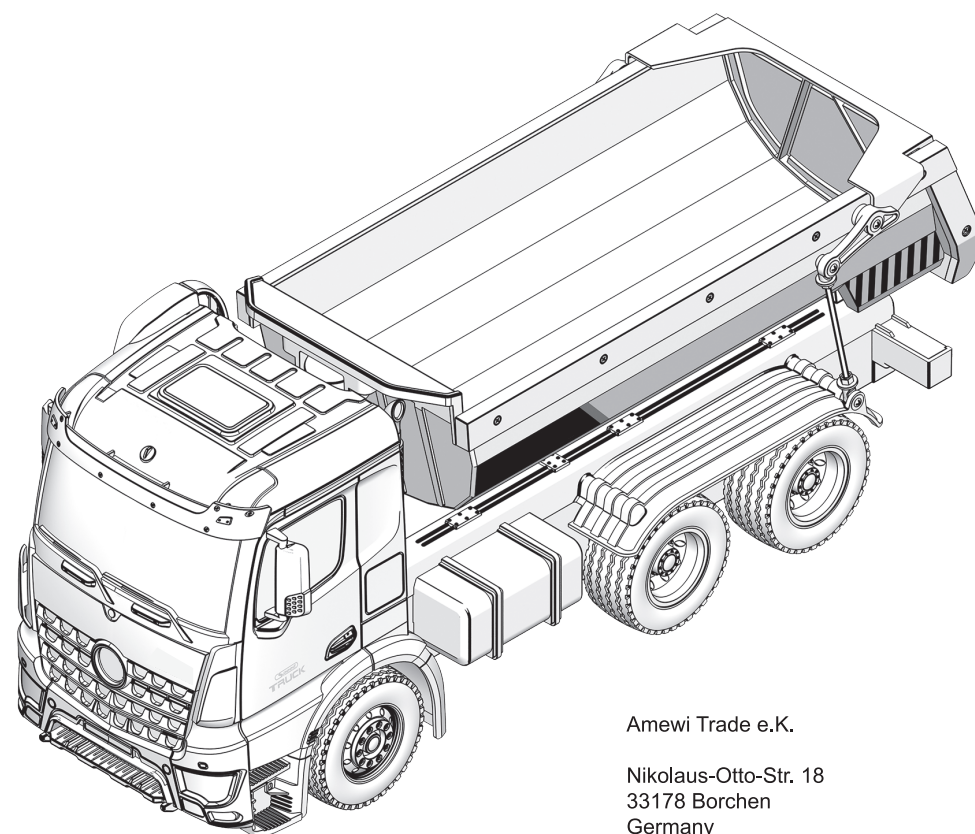

8+ AGES



Mercedes-Benz AROCS 6x4



Amewi Trade e.K.

Nikolaus-Otto-Str. 18
33178 Borchen
Germany

www.amewi.com
www.facebook.com/amewicom/
www.instagram.com/amewi_official/
www.youtube.com/user/Amewicom

Specifications:
Size: approx. 422 x 152 x 181 mm
Weight: approx. 3290g
Battery: 7.4V 2000mAh, XT-30 connector
Remote controller battery: 4 x AA batteries (not included)
Playing time: approx. 30 minutes
Control distance: about 30m
Channel: 10
Function: forward, backward, left-turning, right-turning, bucket push (load 10kg, self-unloading 4kg)

Declaration of Conformity

This product has been manufactured according to actual technical standards. The product is matching the requirements of the existing European and national guidelines. The Declaration of Conformity has been proofed. AMEWI Trade e.K. declares that this product is matching the basic requirements and remaining regulations of the guideline 2014/53/EU (RED). The declarations and documents are stored at the manufacturer and can be requested and applied there.

The full text of the declaration of conformity can be found at: <https://amewi.com/de/downloads/index/search/>

For additional questions to the product and conformity please contact:
AMEWI Trade e.K., Nikolaus-Otto-Str. 18, DE-33178 Borchen, Fax: +49 (0)5251 / 288965-19, Email: info@amewi.com.

Security and Hazard Warnings

Attention! For damage, caused by disregarding of the manual, warranty expires!
We are not liable for secondary failures, material or personal damage, caused by improper usage or disregarding the security notices.
Attention! Based on security and registration (CE) reasons, it is forbidden to modify the product personally. Do not disassemble the product.
Attention! Small parts. Danger of suffocation or risk of injury caused by small parts.

The product is not allowed to get moist or wet. The product is only allowed to be used on flat and clean surfaces. Even a drop down from a small height can cause damage to the product. Usage of more than one Products of same Frequency at the same time is not possible, because it will affect each other.

Battery Notice and Battery Disposal

Attention! Battery do not belong in children's hands. A change of the battery has to be done by an adult person. Never mix chargeable batteries with non-chargeable batteries. Never mix fully charged batteries with almost empty batteries. Never mix batteries of different capacities. Never try to charge dry batteries. Take care of the correct polarity. Defective batteries belong to special waste. Never leave a charging battery unattended. For questions about the charging time please read the manual or ask the manufacturer.

Disposal

The company AMEWI is registered below the WEEE Reg. Nr. DE93834722 at the foundation EAR and recycles all used electronic parts properly. Electric and electronic products are not allowed to be put in household garbage. Please dispose the product at the end of the lifetime according to the actual laws. You as a customer are responsible by law for the return of all used batteries, a disposal over the household garbage is forbidden!

Batteries containing hazardous substances are marked with the alongside symbols, which point to the prohibition of disposal in household garbage.

Additional notations for the critical heavy metal are: Cd=Cadmium, Hg=Quecksilver, Pb=lead (Label is placed on the batteries, for example below the bottom left trash symbols).

Based on RoHS labeling the manufacturer confirms, that all limit values were taken care of at the time of manufacturing.

Batteries labeled with the recycling symbol can be put into used battery collecting tank. (Most supermarkets have)
They are not allowed to be put into local household garbage.

AMEWI Trade e.K. is involved in the dual system for boxing over the company Firma Landbell AG. All used boxes are collected from partner companies (waste disposal contractor) at private customers (local household), sorted and properly utilized. The Involvement in a Dual System helps to save CO₂ Emissions.

1

Installation of setting battery in truck

1. Loosen screw of battery cover by screwdriver, twist the buckle and take out battery cover.(Pic.1)

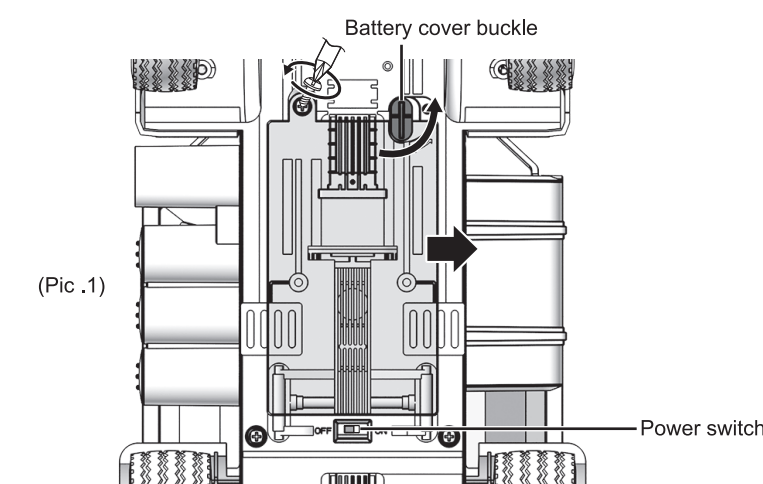

2. Connect rechargeable battery with power port of truck, then put it into the battery box.(Pic.2)

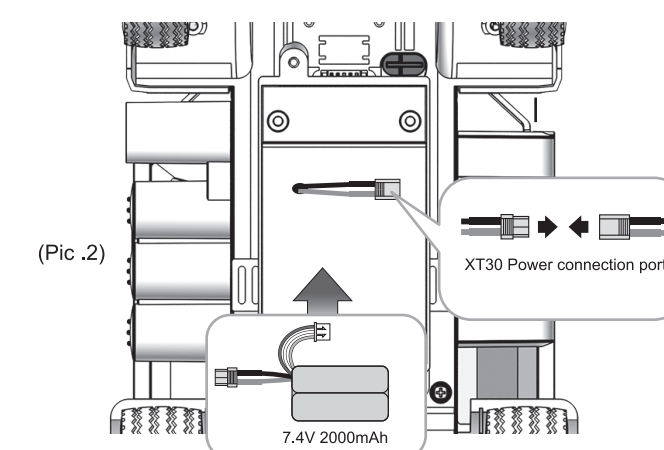

3. Install the battery cover, tighten the screw and twist the buckle back.(Pic.3)

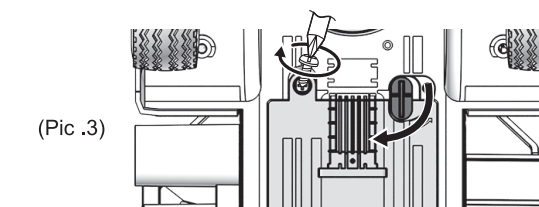

2

BATTERY CHARGING INSTRUCTIONS

CHARGING METHODS

Connect the white port of Li-Ion to USB charging port, as shown in the Figure, and ensure port can be connected tightly and correctly, then insert the USB charging plug into power adapter, and perform charging.

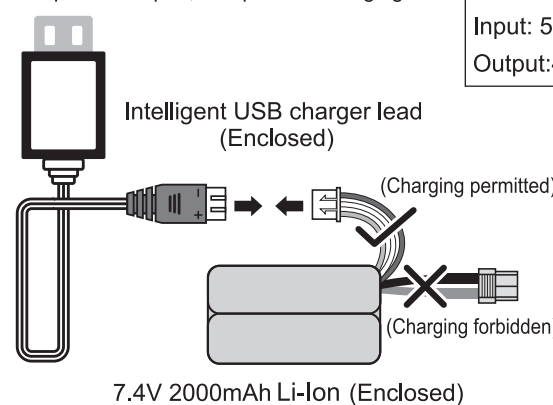

BATTERY/USB PARAMETERS

Battery specifications: 18650
7.4V 2000mAh
Intelligent USB balance charger with overcharge protection
Input: 5.0V 1-2A
Output: 4.2V 800mAh X2

INDICATOR LIGHT STATUS AT THE TIME OF CHARGING:

Uncharged state: red light always lit
Charged state: Red light always lit + Green light flashes
Full charging state: Red and green light always lit
Charging period: 5-7 hours
When battery is charged, please pull off the USB charger lead in time.

Installation of Remote Control Battery

- Loosen the screw of battery cover by screwdriver and take out battery cover. (Pic.1)
- Put four 1.5V "AA" non-rechargeable batteries (batteries need to be purchased separately) into the battery box to the right polarity at the bottom of remote control. (Pic.2)
- Install the battery cover and tighten the screw. (Pic.3)

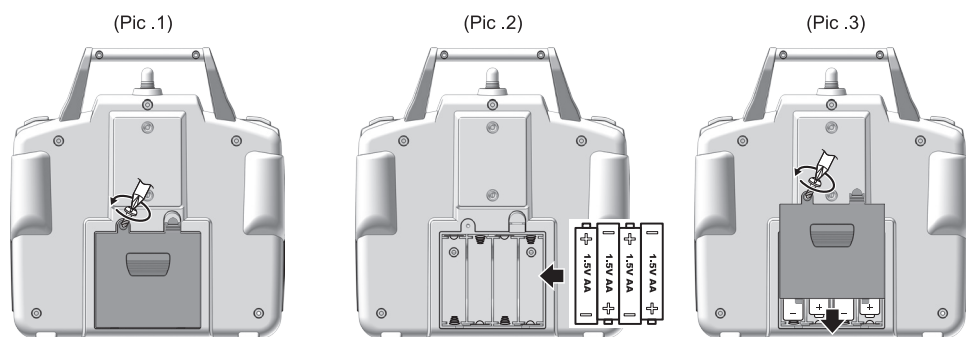

ATTENTION: Batteries shall be put to the right polarity.

3

Operation of remote control

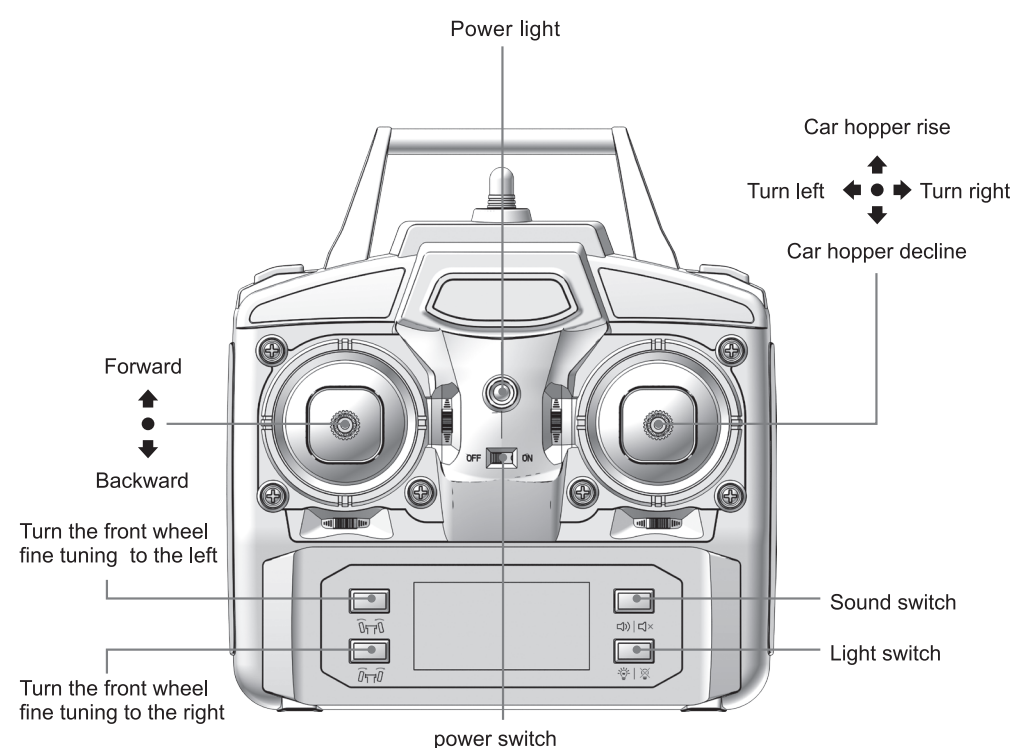

4

The match of R/C frequency and power on

This product is controlled by the frequency of 2.4GHz. When playing it at the first time, please turn on the power and wait for the automatically matching of frequency. The sound "beeps" given by the product indicates that the frequency is matched successfully.

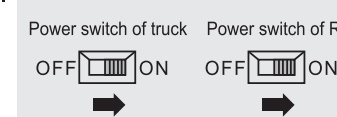

Control of light and sound



Press this button to turn on the sound, and press once more to turn it off.



Press this button to turn on the light, and press once more to turn it off.

The operation of front wheel

When the car can't go straightly, please control the wheel to the left or right fine tuning.

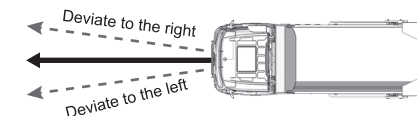

Rectification of deviation to the left

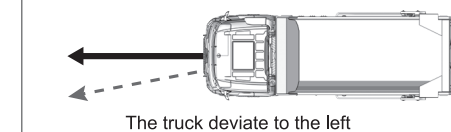

Press this button, and the rear wheels will turn right lightly.

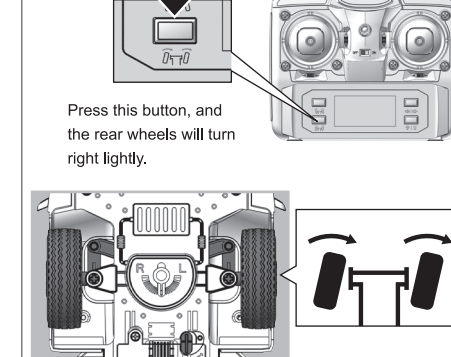

Rectification of deviation to the right

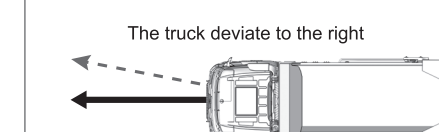

Press this button, and the rear wheels will turn left lightly.

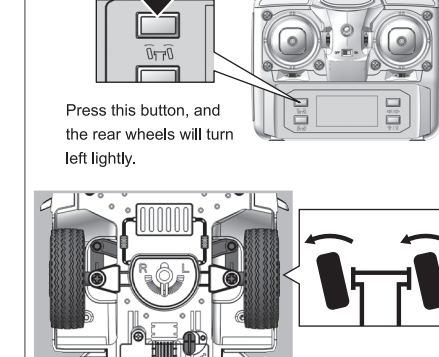

5

Operation of playing the truck

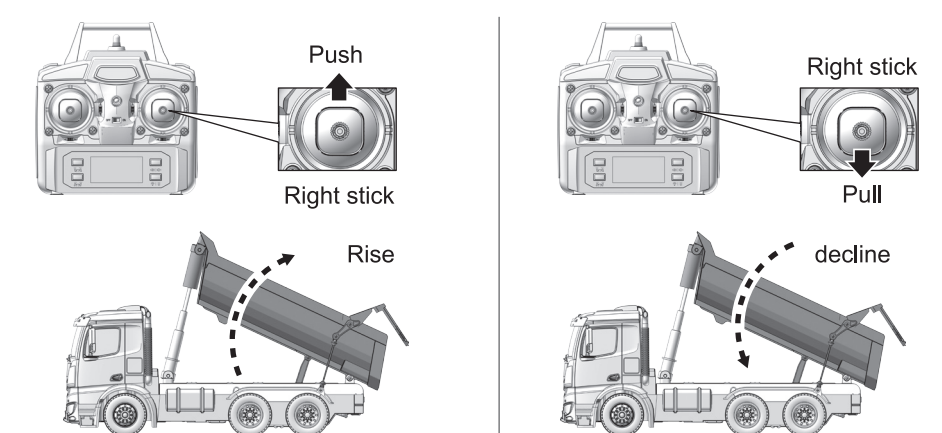
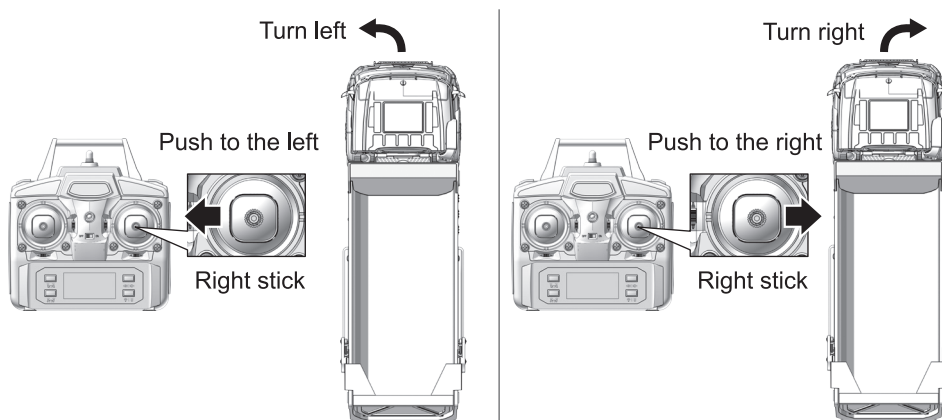
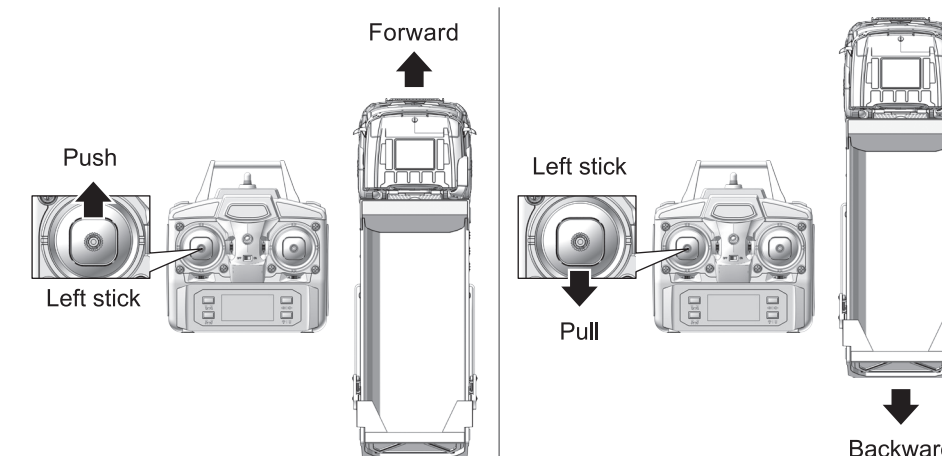

6