

reolink



User Manual V2.0

4 MegaPixels Network Camera

1080P Network Camera

Reolink Client Software !

Thank you for purchasing the Reolink Network Camera .

For the latest User Manual, Product Updates and more information about the products , please visit our website at :

<https://reolink.com/>



CAUTION

RISK OF ELECTRIC SHOCK
DO NOT OPEN



CAUTION: TO REDUCE THE RICK OF ELECTRIC SHOCK DO NOT REMOVE COVER. NO USER SERVICEABLE PARTS INSIDE. REFER SERVICING TO QUALIFIED SERVICE PERSONNEL.



The lightning flash with arrowhead symbol, within an equilateral triangle, is intended to alert the user to the presence of uninsulated "dangerous voltage" within the products ' enclosure that may be of sufficient magnitude to constitute a risk of electric shock.



The exclamation point within an equilateral triangle is intended to alert the user to the presence of important operating and maintenance (servicing) instructions in the literature accompanying the appliance.

WARNING: TO PREVENT FIRE OR SHOCK HAZARD, DO NOT EXPOSE THIS UNIT TO RAIN OR MOISTURE.

CAUTION: TO PREVENT ELECTRIC SHOCK, MATCH WIDE BLADE OF THE PLUG TO THE WIDE SLOT AND FULLY INSERT.

GETTING STARTED



We have developed user-friendly products and documentation. You may download the software and manual from <https://reolink.com/software-and-manual/>



If you have any questions, you may refer to <https://reolink.com/faqs/>



If you may need any technical support, please contact us at service@reolink.com [| support@reolink.com



You may download Firmware from <https://reolink.com/firmware/>

FCC Verification

Note: This equipment has been tested and found to comply with the limits for Class B digital device, pursuant to part 15 of the FCC Rules. These limits are designed to provide reasonable protection against harmful interference in a residential installation. This equipment generates, uses and can radiate radio frequency energy and, if not installed and used in accordance with the instructions, may cause harmful interference to radio or television reception, which can be determined by turning the equipment off and on, the user is encouraged to try to correct the interference by one or more of the following measures:

- Reorient or relocate the receiving antenna
- Increase the separation between the equipment and the receiver
- Connect the equipment into an outlet on a circuit different from that to which the receiver is connected
- Consult the dealer or an experienced radio/TV technician for help

These devices comply with part 15 of the FCC Rules. Operation is subject to the following two conditions:

- These devices may not cause harmful interference, and
- These devices must accept any interference received, including interference that may cause undesired operation.

Important Note :

All jurisdictions have specific laws and regulations relating to the use of cameras. Before using any camera for any purpose, it is the buyer's responsibility to be aware of all applicable laws and regulations that prohibit or limit the use of cameras and to comply with the applicable laws and regulations.

FCC Regulation (for USA):

Prohibition against eavesdropping

Except for the operations of law enforcement officers conducted under lawful authority, no person shall use, either directly or indirectly, a device operated pursuant to the provisions of this Part for the purpose of overhearing or recording the private conversations of others unless such use is authorized by all of the parties engaging in the conversation.

WARNING

Modifications not approved by the party responsible for compliance could void user's authority to operate the equipment.

IMPORTANT SAFETY INSTRUCTIONS

- Make sure product is fixed correctly and stable if fastened in place
- Do not operate if wires and terminals are exposed
- Do not cover vents on the side or back of the Camera and allow adequate space for ventilation

RoHS:

This product is fully compliant with the European Union Restriction of the Use of Certain Hazardous Substances in Electrical and Electronic Equipment ("RoHS") Directive (2002/95/EC). The RoHS directive prohibits the sale of electronic equipment containing certain hazardous substances such as lead, cadmium, mercury, and hexavalent chromium, PBB, and PBDE in the European Union.

BATTERY INFORMATION

This product contains a removable battery. If you need to replace or dispose of the internal battery.

The battery is located on the main board of the Camera. It is a primary lithium CR2032 button cell.

To access, remove and/or replace the battery:

- Ensure the Camera is turned OFF. NEVER open the Camera's case while power is connected.
- Remove the five screws holding the cover on the Camera.
- If replacing the battery, ensure that it is an exact match for **size, type and capacity**.
- Be sure to safely dispose of the battery. The process for battery disposal/recycling varies from location to location, please check with the relevant local authority for method.

BATTERY SAFETY INSTRUCTIONS

- Do **NOT** attempt to open, puncture, disassemble or modify the battery in any way.
- Do **NOT** subject it to sudden shock or heat.
- Do **NOT** dispose of battery in fire.

Getting Started.....	2	Maintenance.....	29
Notice.....	4	Performance.....	30
Contents.....	5	Reboot.....	30
Connection Diagram	6		
 		Device	
Client Software		SD Card.....	31
Install Software.....	7		
Live View.....	8	User	
Local Setting.....	11	Online User.....	32
Device Settings.....	12	Add User.....	32
Display Camera	13	Manager User.....	33
Recording		Preview Basic Setting.....	34
Encode.....	14	Preview Advanced Setting.....	35
Option.....	15		
Schedule.....	15	 	
 		Warranty Terms & Conditions	36
Network			
General.....	16		
Advanced.....	17		
DDNS Setup.....	18		
NTP Setup.....	19		
Email Setup.....	20		
FTP Setup.....	21		
Network Status.....	22		
WiFi Settings.....	23		
Alarm			
Motion Detection.....	24		
Alarm Motion.....	25		
Motion Detection Schedule.....	26		
System			
General	27		
Information.....	28		

This page shows how Camera connect to the Network System

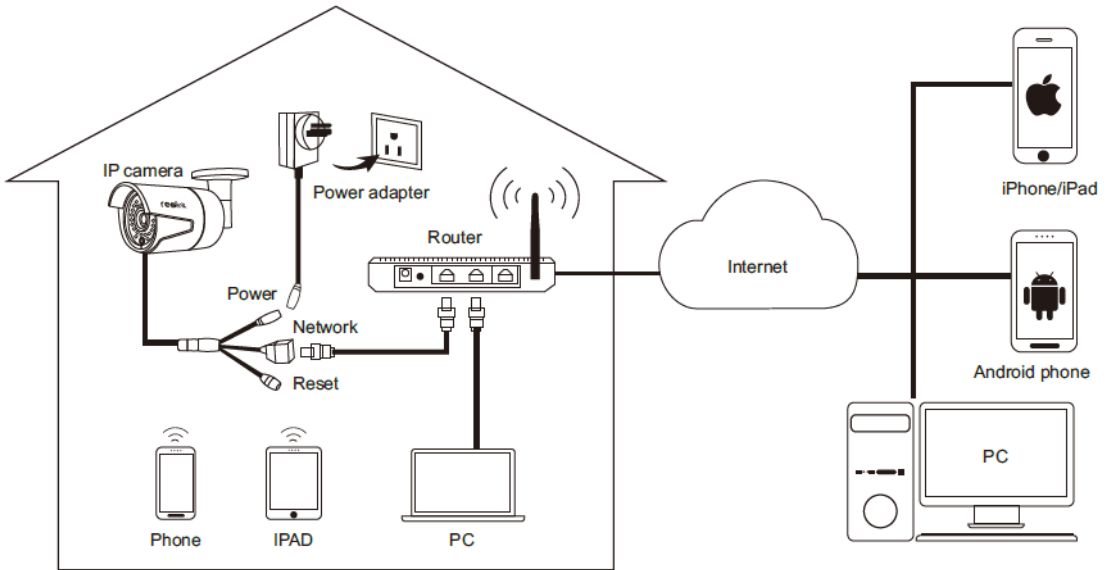

! Attention: For Initial Setup, connect the camera by network and power cable. Then follow the steps below.

1. Connect Network Cable to the Camera, and other end to the POE Switch or Router.
2. Connect Power adapter to the camera and turn on the power.
3. You may use your Mobile devices or PC to setup the camera.

You may view the camera from local network or Internet after successful set-up.

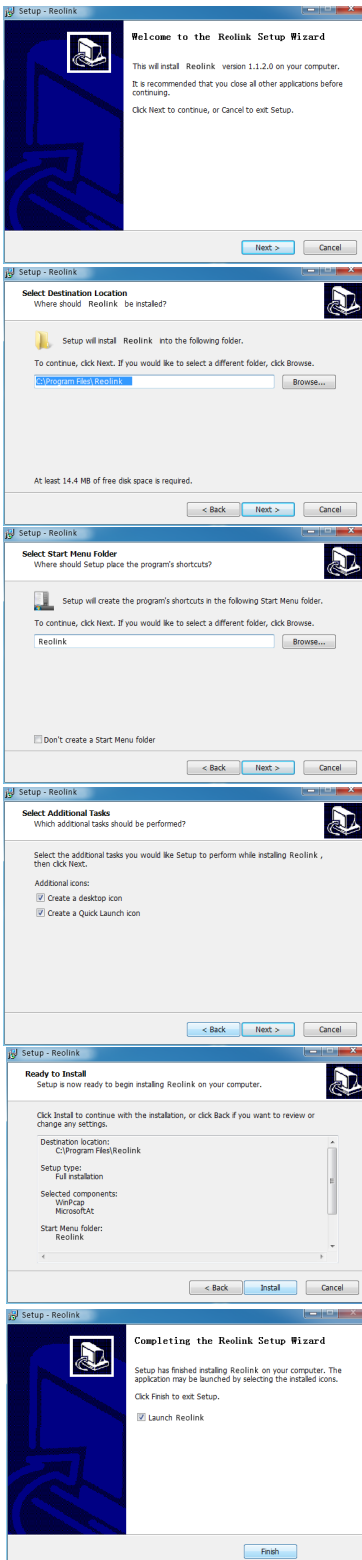

Reolink Client Software

The Reolink software will allow you to:

- view images from your Camera real-time,
- playback recorded footage,
- copy footage to your local PC and
- adjust settings and configure the Camera.

In fact, the Reolink software is so powerful, you don't need to connect a monitor to the Camera. You only need a computer on the same local network where the Reo-link camera is connected.

For quick and easy configuration of the Camera's settings, recording quality and schedule, we suggest to use the remote interface in *Reolink*.

How to install Reolink Software:

- Insert the included CD into your computer.
- Locate the file called **Reolink** and run this file.
- you may be asked by UAC (User Account Control) to allow Reolink to "make changes" to your system. Select **Allow** or **Continue**.
- You will see an installation wizard. Simply follow the procedure to install the software.
- Once the ReoLink software is installed, it should automatically detect your Camera on your network.

Minimum PC Requirements:

- 2.0GHz or faster CPU
- 2 GB or more RAM
- 10/100Mbps Network
- Internet connection
- 1024x768 resolution

Supported Operating Systems

Microsoft Windows XP, Microsoft Windows Vista, Microsoft Windows 7
 Setup your PC (Windows)

Log on to Reolink

After installing the Software, you will see below screen.



1. Click Add Device Button on the top right.
2. Click Scan Device in LAN.
3. Double click the device you want to add then device info will be displayed.
4. Input the password (default password is Blank), if you already create password on Reolink App, you need to use the password you created to log in.
5. Then click OK to Log in.

To connect from your PC to your Camera, make sure your Camera is on and all connections are ok.

IP Address

- If your Camera is in the same LAN network with your PC, you can click Search to automatically get the IP address.
- Then, enter your **Username** (the default of **admin** is already entered) and **Password** (default is **blank**), you need to use the password which you created on Mobile or create a new password here to continue, then click **Login**. After a few seconds, you will see your cameras live on your PC.

UID

- If your camera is not in the same LAN network with your PC, you can use UID connect mode.
- You can manually type the UID under the UID QR code which is on the body of camera UID field.
- Then, enter your **Username** (the default of **admin** is already entered) and **Password** (default is **blank**), you need to use the password which you create on Mobile or create a new password here to continue, then click **Login**. After a few seconds, you will see your cameras live on your PC.

Using the Live View Screen

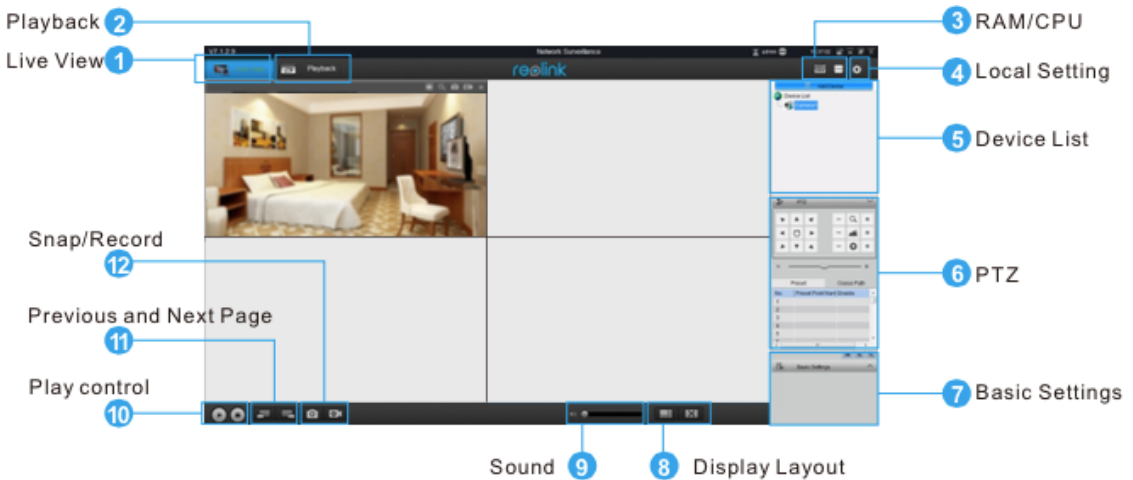

Live View is the default mode for the Camera.



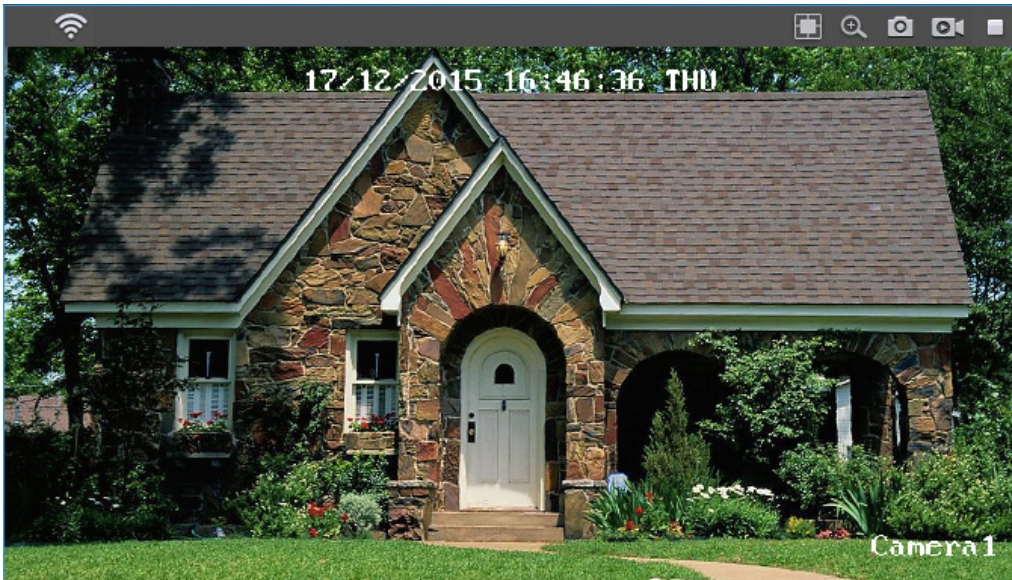

1. **Live View:** Shows the live view of the camera
2. **Playback:** Remotely playback video recorded to Camera or PC or NVR
3. **RAM/CPU:** Place your mouse over RAM icon, it will show the memory loading performance
CPU: Place your mouse over CPU icon, it will Shows the CPU loading performance
4. **Local Setting:** can set the record/Download/Capture path of the file
5. **Device List :** Shows the device connected to the software
6. **PTZ :** Set the Pan/Tilt/Zoom Parameters
7. **Basic Settings:** Can set OSD/Encode/Image parameters
8. **Display Layout :** Choose 1/4 and multi-channel view up to 32 Channels
9. **Sound:** you may enable/disable the sound and adjust its volume.
10. **Play Control:** Choose to play Clear/Balanced /Fluent/Auto Live video
11. **Previous and Next Page:** choose which group of channel to display during multichannel view
12. **Snap/Record:**
 - Snap:** Capture the image of the Channel which you choose
 - Record:** Initiates manual recording, and stop recording

More details will be explained in the next pages.





Click  to compress the image to centre or click to  stretch image to full window.



Click  to show the digital zoom page . Here you can click

 choose the zoom region

 Zoom In  Zoom Out

 restore zoom back to default setting  Exit Digital zoom

Click Capture button  to take a snapshot of the image

Record Button  Manual start record or stop record of the selected channel. During the recording, on Device Tree area, status icon next to device name will show  record icon on the device .

Click  to start Live View.

Click  to Stop Live View.

This Symbol  shows your camera with WIFI Functions .

Click Gear Icon  Local Settings button on the upper right of the screen. The local Settings screen is where you can customise how ReoLink will store and process footage on the local PC when you download it from the Camera.

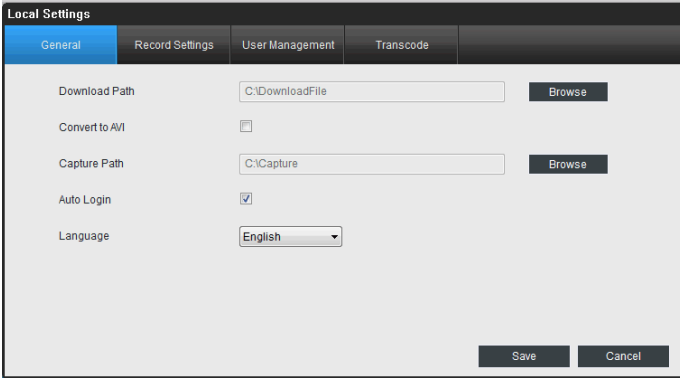

The screenshot shows the 'Local Settings' window with the 'General' tab selected. It contains the following fields:

- Download Path: C:\DownloadFile (with a 'Browse' button)
- Convert to AVI:
- Capture Path: C:\Capture (with a 'Browse' button)
- Auto Login:
- Language: English (dropdown menu)

Buttons for 'Save' and 'Cancel' are at the bottom right.

Download Path: Where ReoLink will save footage that you've downloaded from the Camera.

Convert to AVI: When selected, ReoLink will use your PC to *transcode* footage from the Camera's native format (H.264) into AVI file .

Capture Path: Where ReoLink will save still images captured using the snapshot function.

After finished Setting, click Save, Popup box will note "Save Succeed"!

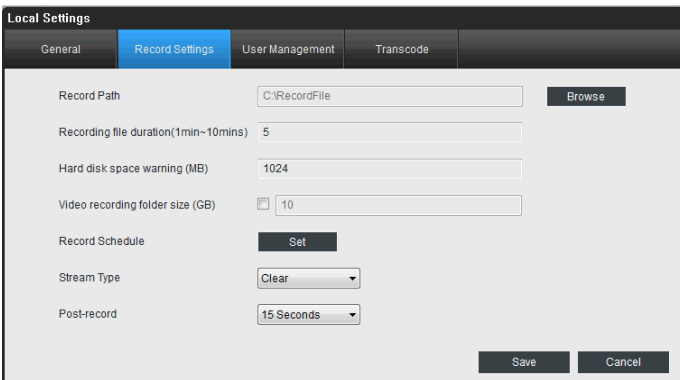

The screenshot shows the 'Local Settings' window with the 'Record Settings' tab selected. It contains the following fields:

- Record Path: C:\RecordFile (with a 'Browse' button)
- Recording file duration(1min~10mins): 5
- Hard disk space warning (MB): 1024
- Video recording folder size (GB): 10
- Record Schedule: Set (button)
- Stream Type: Clear (dropdown menu)
- Post-record: 15 Seconds (dropdown menu)

Buttons for 'Save' and 'Cancel' are at the bottom right.

Record Path: Where ReoLink will save recordings if you select Record from the Preview screen.

You may set the Recording File duration, folder size, Recording Schedule, the stream File Type and choose the record file time length from this page .

After finished setting, click Save, Popup box will note "Save Succeed"!

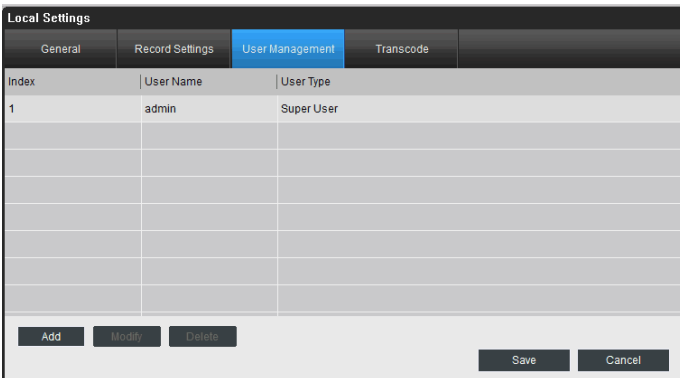

The screenshot shows the 'Local Settings' window with the 'User Management' tab selected. It displays a table with user information:

Index	User Name	User Type
1	admin	Super User

Buttons for 'Add', 'Modify', 'Delete', 'Save', and 'Cancel' are at the bottom.

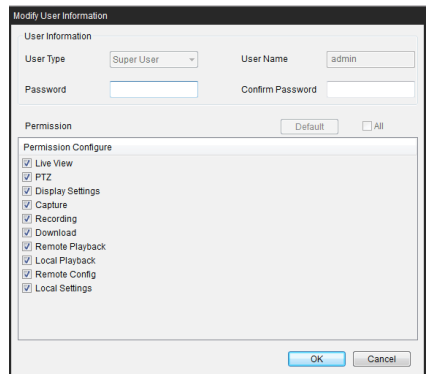

The screenshot shows the 'Modify User Information' dialog box. It contains the following fields:

- User Type: Super User (dropdown menu)
- User Name: admin
- Password: (empty text field)
- Confirm Password: (empty text field)
- Permission: Default (radio button), All (checkbox)
- Permission Configure (checkboxes):
 - Live View
 - PTZ
 - Display Settings
 - Capture
 - Recording
 - Download
 - Remote Playback
 - Local Playback
 - Remote Config
 - Local Settings

Buttons for 'OK' and 'Cancel' are at the bottom right.

Double Click the user you want to set, Then you will see the Modify user information window. You can set the password for the user and set the permission for this user. Click OK , Then click Save to keep the settings.

On This page , allows you to transfer the H.264 file to AVI file .

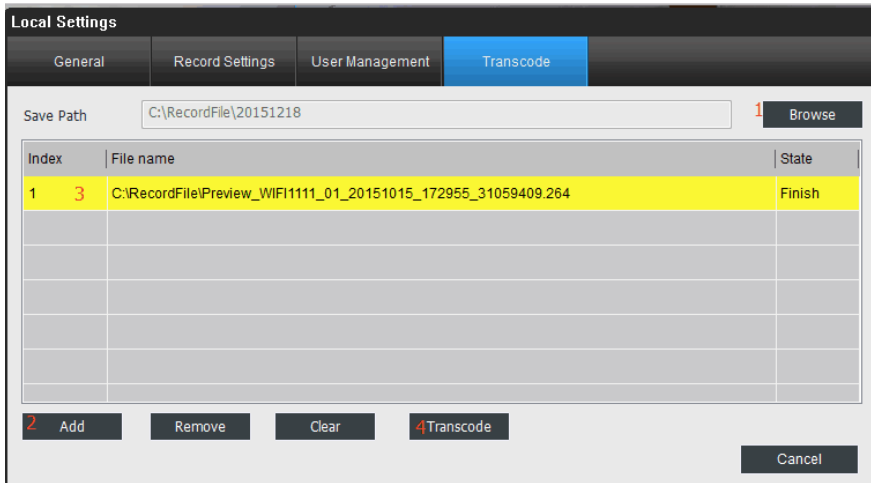

- 1.Click the Browse to setting the Save Path .
- 2,Click Add to add the file which you want to transcode to AVI format
- 3,Choose the file , then click Transcode ,On Status it will show Start and Finish after transcode succeed .

Client Software - Device Settings

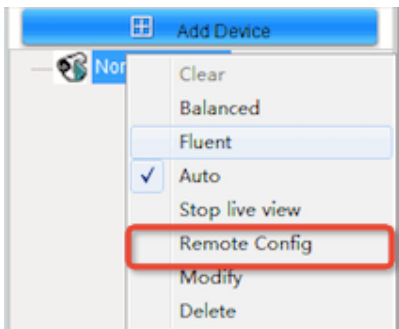

Right Click the Device , it will show the setting window, Right click the Remote Config , you will see below window and set the the related parameters.





Click OSD icon, you will see below

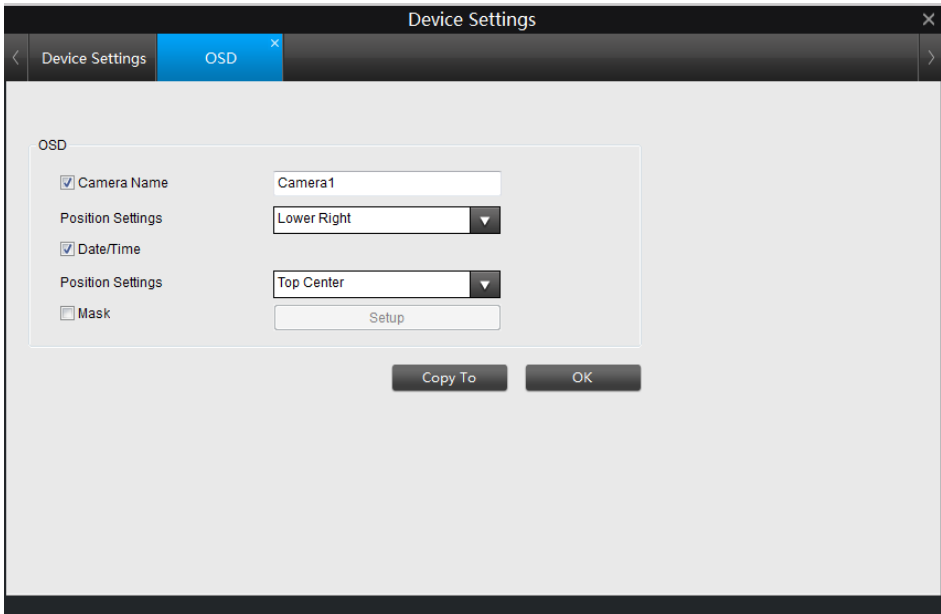

- **Channel Name:** Enable/Disable channel name, you may also rename the Channel name here.
- **Position Settings:** you may put the Channel name on the upper left, lower left, upper right, lower right, top center or bottom center.
- **Date /Time :** Enable or disable to show the date and time on the screen.
- **Mask (Check Box):** Turns on/off the masking function.
- **Mask (Setup):** Creates a black privacy overlay which masks part of your images. Will affect recordings.

Click OK to keep the settings, also you can copy the above settings to other channels, choose checkbox on the copy to window, then click OK.

On the bottom of the window it will show , Channel Setting Succeed.



The **Recording: Encode** menu allows you to alter and customise how the Camera records footage and “encodes” the files. You can choose and alter:

- the resolution (per channel),
- the frame rate (how many images per second the Camera records), and
- the data-rate of each video stream. The higher the data rate, the “better” your images will look.

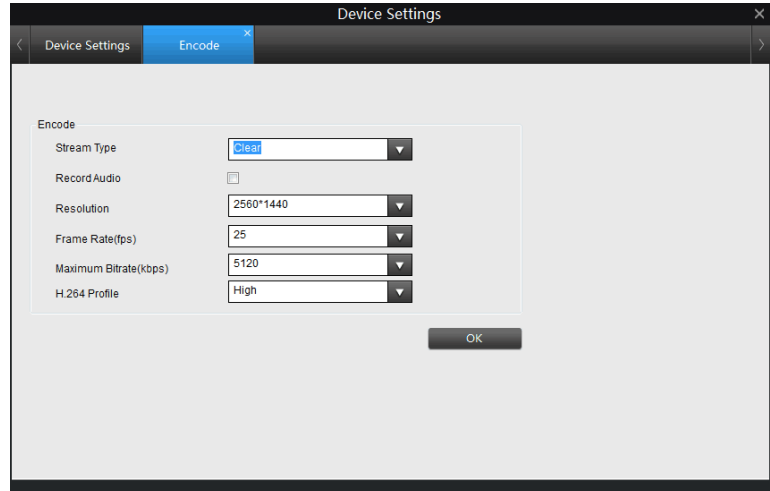

- **Stream Type:** Whether you're editing the parameters for the mainstream or the sub-stream.
 - **Clear(Main-Stream):** the video feed that the Camera will record and display. This is the higher-quality stream.
 - **Fluent(Sub-Stream):** the video stream that the Camera will send to remote devices via a network or the Internet. It is the lower-quality stream as a reduction in video size makes it easier to send over a network.
- **Record Audio:** recording with Audio
- **Resolution:** Tells how many “little dots” are going to make up your image.
- **Frame Rate:** Tells the number of frames per second (fps) that the Camera will record. Reducing the number of fps will **not** save hard drive space but potentially improve the data-rate per frame.
- **Max. BitRate(Kbps):** The actual amount of data that the Camera will use to record video. The higher the bitrate, the more space each recording will take up on the hard disk. Generally speaking, recordings encoded at higher bitrates will be of better quality, especially when recording movements.
- **H.264 Profile:** Reolink can support Baseline/Main/High profile .
 - BaseLine :The basic image, short delay and less competitive
 - Main: Main Image ,with high encoding
 - High: Super image, used for streaming applications.

The main-stream uses a variable bitrate to record video - the more movement occurs in the video, the higher the bitrate will have to be.

If you set a high bitrate but a low frame rate, the Camera will still use all the data, resulting in potentially higher quality per frame than at higher frame rates.

The sub-stream uses a constant bit-rate to makes the video easier to stream over a network or the Internet.

Note: Both the main-stream and the sub-stream are always operating - in fact, the sub-stream forms part of the main-stream. The options will affect the output quality of each stream, but won't change which one is being used in different circumstances.

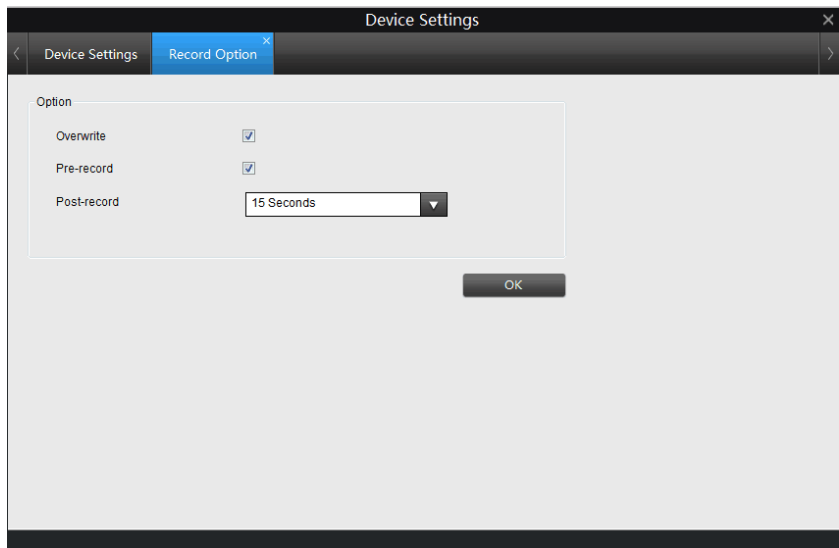

Overwrite When enabled, the SD card will record over the files already stored on the card. The camera will always record over the oldest files on your SD card first.

Pre-record While Pre-Record is enabled, the camera will record a few seconds *before* an event occurs.

Post-record How long after an event occurs that the camera will continue to record.

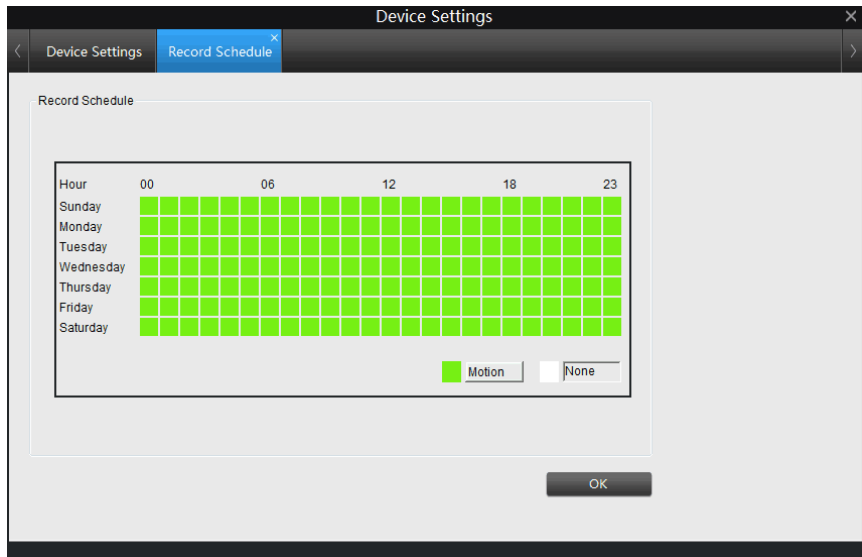

Here you can setting the record schedule for Motion detection on SD Card .

SD card can only storage Motion Detection alarm , it don't support continuous recording .

The SD card will only record when it detects something moving in front of a camera, and will then only record footage from the camera(s) that do detect motion.



Device Settings

Device Settings Network General

General

Network Access: DHCP

IP Address: 192 . 168 . 1 . 100

Subnet Mask: 255 . 255 . 255 . 0

Gateway: 192 . 168 . 1 . 1

Auto DNS: Auto DNS

Static DNS: Static DNS

Preferred DNS: 202 . 96 . 134 . 133

Alternate DNS: 202 . 96 . 128 . 68

Mac Addr: EC:71:DB:5A:0D:4E

OK

- **Network Access:** Here you can choose between the three different types of networks that the Camera can be connected to. The three types of networks are:
 - **DHCP:** DHCP is a system where one device on your network (usually a router) will automatically assign IP address to device connected to the network.
 - **STATIC:** Static networks require all devices to have their IP addresses manually defined, as there is no device dedicated to automatically assign IP address.
 - **PPPoE:** An advanced protocol that allows the Camera to be more directly connected via a DSL modem. This is an option for advanced users only.
- **IP Address:** Just as Home and Office needs to have an address which identifies their location on the road network, the Camera uses IPv4 addressing, which consists of four groups of numbers between 0 and 255, separated by periods. For example, a typical IP address might be “192.168.1.24” or similar.
- **Subnet Mask:** If the IP address is like a street address, then a subnetwork is like your neighbourhood. This will be formatted in a similar way to the IP address (ie. four numbers up to 255 separated by periods) but contain very different numbers. In the above example, the Subnet Mask might be something like: “255.255.255.0”.
- **Gateway:** This is the address of the “way to the Internet.” To continue the road analogy, this is like your local access point to the highway. This is an IP address in the same format as the others, and is typically very similar to the IP address of the Camera. To continue the above example, it might be something such as: “192.168.1.254”.
- **Auto DNS / Static DNS:** Choose how you would like to define your DNS servers. We recommend leaving it on Auto configuration.
- **Auto DNS:** The Camera will automatically choose a DNS server. This is the recommended setting.
- **Static DNS:** If you need to manually define a DNS server, then choose Static DNS. This is recommended for advanced users only.
- **Preferred DNS Server:** “Domain Name System”. Everything on the Internet is located via an IP address - however, for ease of use, we associate domain names (such as “www.exampledomainname.com”) with those IP addresses. These index are accessible in many locations online, and we call those locations “DNS servers”.
- **Alternate DNS Server:** A backup DNS server. This is for redundancy - your Camera will probably work without one.
- **MAC Address:** The Media Access Control address. This is a unique code which nothing else should share. You can’t change this one - it’s pre-set when the Camera ships out.

***Note:** Many of the following networking settings are not required when using ReoLink P2P for remote access.

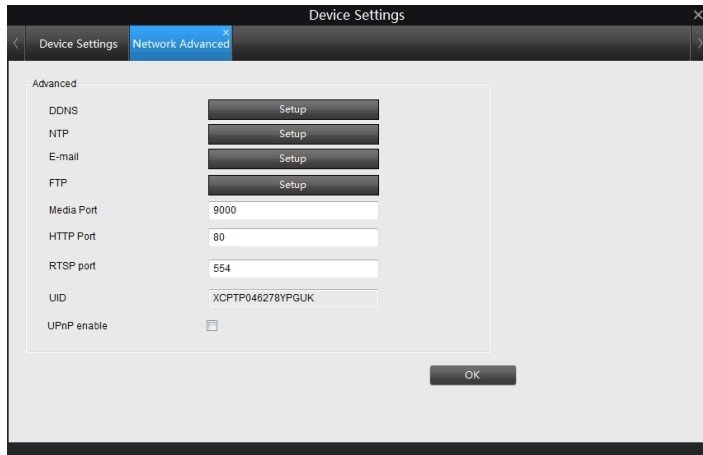

- **DDNS:** The place to configure the Camera to automatically update a dynamic DNS service. If you want to remotely access the Camera via the Internet, you'll probably need to configure a DDNS account.
- **NTP:** Network Time Protocol. If you've got the Camera connected to the Internet, you can have it automatically sync time with an online server.
- **Email Settings:** You may configure the Camera to work with an email account of your choice. This must be correctly configured for the Camera's auto-email feature to work.
- **FTP:** File Transfer Protocol, you can use FTP to transfer files between Camera and computers on a network.
- **Media Port:** Camera will use server port to send information through. Please note that,

You'll need to enable UPnP on your router so your router can selectively open these ports, allowing the Camera to communicate via the Internet. If your router doesn't support UPnP, You may either get a new router (which support UPNP) or you can manually forward ports from the router to the Camera. Port Forwarding is a technical process and may require router knowledge.

The default port number is **9000**, which is not used by many other devices/programs. However, if you have another Camera or Camera-like device, this port may be used already. If this is the case, change this value to be unique.

- **HTTP Port:** This is the port through which you will be able to log in to the Camera. it will need to be forwarded properly in order to ensure smooth, latency-free communication. The default value is "85", as this port is seldom used by other devices. If another device on your network is using this port, please change to other value. This is the port number you'll need to remember when logging in remotely from a remote PC via the HTTP interface.

What port number(s) should I use?

If the default port numbers are in use (85 and/or 9000) if 85 is already taken, try 86 or 87.

There's no "right" port number, any port number will work, avoid using port numbers 80, 81, 82, 88, 90, and 99 as these are often used by other devices.

- **RTSP Port:** Real Time Streaming Protocol", you may use this port to send the streaming file to Realplayer, the default RTSP port is 554
- **UPNP enable (This feature is not required if you are using ReoLink P2P to access the Camera):** UPnP makes configuring your network easier and faster. To use the UPnP setting on the Camera, you'll need a router which supports this feature, with UPnP enabled. Note that many routers which do support UPnP do not come with the feature enabled by default. You may need to ask your Internet service provider to turn it on.

When UPnP is enabled on your Camera and your router, the Ports that the Camera requires to be open for access to and from the Internet will automatically be opened and closed as necessary by your router, saving you the trouble of manually forwarding these ports. If UPnP is not enabled, or your router does not support this feature, you'll need to forward the ports the Camera uses from the router to the Camera - since this is a technically challenging process, we strongly recommend using UPnP if possible.

UID: The Camera's **U**nique **I**Dentifier code for P2P. For convenience, you may have this code sent to your email account by clicking the **Send UID** button(provided that you've already set up your email account).

DDNS Setting

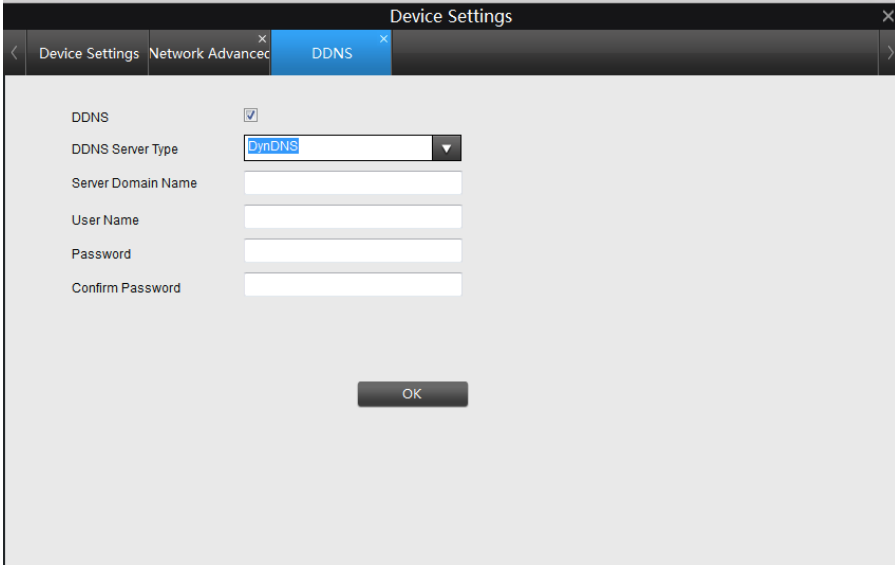

The screenshot shows a 'Device Settings' window with a tabbed interface. The 'DDNS' tab is active. The settings are as follows:

- DDNS:
- DDNS Server Type:
- Server Domain Name:
- User Name:
- Password:
- Confirm Password:

An 'OK' button is located at the bottom center of the window.

In the same way as your home network can use static or dynamic IP addresses, many Internet providers don't issue (or charge more for) a static IP address for users. The easiest way to find out is to contact your Internet Service Provider. Alternately, you can access the www.whatismyip.com service, make a note of your IP, then reboot your router/gateway. This should refresh your Internet connection. If your IP address changes, you have a dynamic IP address. If it stays the same, you may have a static IP - contact your ISP to confirm.

- **DDNS Type:** Choose the server that you're using.
- **Server Domain Name:** Enter the host name that you set up in your DDNS service. This is the address you use to access your network.
- **Username and Password:** Enter the username and password you setup with your DDNS server. These do not have to match your username/password combination in either your Camera or router. (for the sake of security, we suggest making them different).
- **Confirm Password:** Retype the password to confirm

If the test is unsuccessful, a message will appear onscreen informing you that the "Update was Unsuccessful". This could mean that there's a problem with your network setup, or there's a problem with the DDNS Account Name and Password you're using.

The screenshot shows the 'NTP' configuration screen within a 'Device Settings' application. The interface includes a breadcrumb trail at the top: 'Device Settings' > 'Network Advanced' > 'NTP'. The main configuration area contains the following fields:

- NTP Server:** A dropdown menu with 'pool.ntp.org' selected.
- NTP Port:** A text input field containing '123'.
- Enable Auto-Synchronize:** A checked checkbox.
- Synchronize Every:** A text input field containing '720', followed by the label 'Minutes' and a range '(60-65535)'.

At the bottom of the screen, there are two buttons: 'Synchronize' and 'OK'.

NTP Setup

- **NTP Server:** The server you intend to use to access the current date and time. The default is **pool.ntp.org**.
- **NTP Port:** The port that the NTP server uses. The default for pool.ntp.org is **123**.
- **Enable Auto-Synchronize:** click the checkbox to enable Auto-Sync
- **Synchronize Every :** to set the Sync interval time .

Important: If you have enabled NTP - set this to the time zone where you are. For example, people in Eastern Australia (Canberra, Sydney and Melbourne) choose GMT+10:00, whilst the Eastern Time zone in the USA and Canada is GMT-05:00. (GMT stands for Greenwich Mean Time - it's the baseline that keeps all the different time zones in sync.)

NOTE: Some NTP servers are NOT fully compatible with DST (Daylight Savings Time). This may cause your system to double-count adding one or removing one more hour than they should, or cancel each other out. You may need to change your time zone to adjust accordingly or simply not use NTP and DST simultaneously.

We suggest using **Gmail** as your email client - it's quite easy to set up an account and use it solely for the Camera. Other email servers may not work correctly. For the Auto-Mail function to work correctly, the Camera will need to be correctly configured with the details of the email servers and addresses you want to use.

- **Enable SSL or TLS:** Whether the email server you're using requires a secure link. This is **on** by default and should be left on if you're using any of the preset email servers.
- **SMTP Server:** You may use below mailbox : Gmail (smtp.gmail.com), Windows Live Mail (smtp.live.com) and Yahoo Mail (smtp.mail.yahoo.com).

You'll need to setup an account with one of these email providers. All offer free email accounts. To signup, visit the email provider's website:

- **Gmail (Google):** smtp.gmail.com
- **Yahoo Mail:** smtp.mail.yahoo.com
- **Windows Live Mail (Hotmail):** smtp.live.com

The Camera will automatically adjust some settings to make the configuration significantly easier. If you want to use a different email server, typically the outgoing email server of their ISP, then you'll need to contact your ISP to learn the correct values.

- **SMTP Port:** The SMTP port used by the email provider of your choice. This field will automatically self-populate if you use one of the presets.
- **Sender Address:** The address you're sending the email **from**. This will be the username you've

set up for the email server you're using, followed by "@" and then the email server. For example: "youraddress@gmail.com" or similar.

- **Sender Password:** The password for the outgoing email account.
- **Recipient Address:** The email address you want the Camera to send emails to. Note that the Camera might send a large number of automatic emails under certain conditions.
- **Attachment :** You can select to attach picture or video when send e-mail or receive only notification.

For motion-based email alerts, this will be an image of whatever triggered the motion detection.

- **Interval:** The length of time that must elapse after the Camera sends an email alert before it will send another.

Short **Interval** settings are likely to lead to huge numbers of alerts being sent by the Camera - perhaps even several emails for one event (if that one event lasts longer than the interval setting). On the other hand, a long interval setting might mean you'll miss a specific update that you needed. It will depend on your requirement.

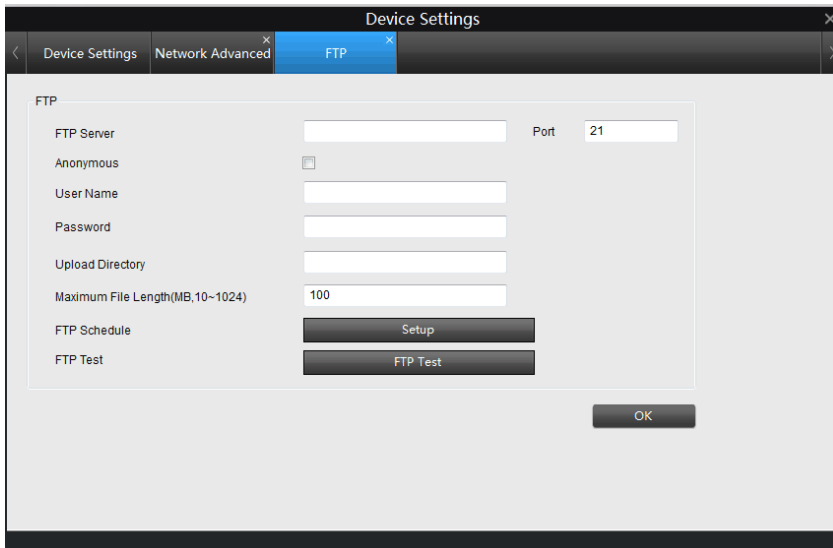

- **FTP:** File Transfer Protocol, you can use FTP to transfer files between Camera and computers on a network.
 - **FTP Server:** Your FTP server address, can be IP address or the FTP link address, then input the FTP port # .
 - **Anonymous:** If your FTP does not need username and password, you can click the Anonymous checkbox, else you need to input your FTP username and password below.
 - **Upload Directory:** You need to input the upload folder name here .
- Maximum File Length: You may manage your FTP storage file size, the default setting is 100MB/file .
- **FTP Schedule:** You may set the FTP schedule time from below window, then click OK to save settings.

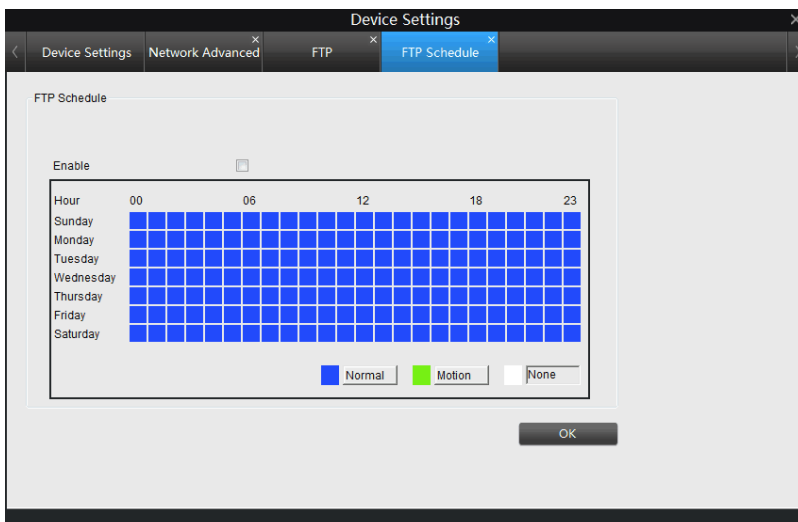

- **FTP Test:** After finished setting, you may click Testing to verify your FTP settings, it will show FTP Test Succeed or FTP Test Failed on the bottom of the window. If setting is failed, please check your configuration again .

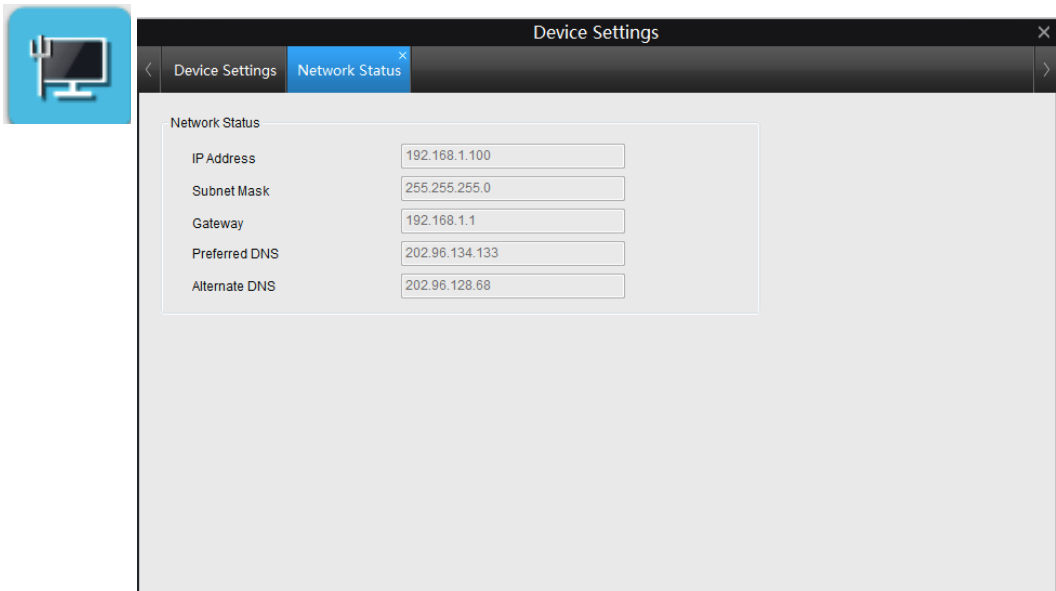

Here you may find the network information of the camera that you are viewing :

- **IP Address**
- **Subnet Mask**
- **Gateway**
- **Preferred DNS**
- **Alternate DNS**

For more details , you can refer to Device Setting -> Network -> General .

Here you can setting the WIFI of the Camera . This function is only valid for the WiFi Camera .

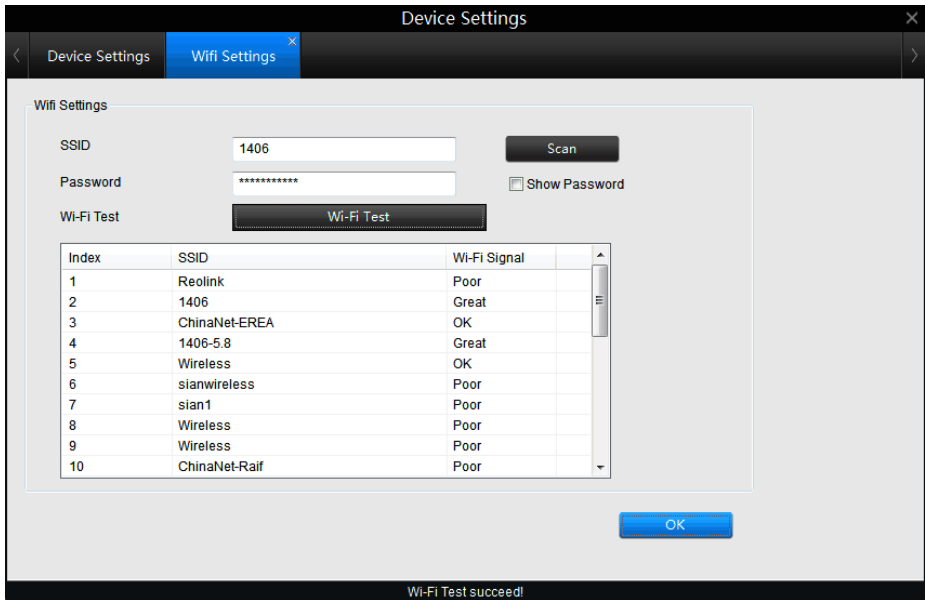

- 1, Click Scan Button , it will show all the WiFi Signal SSID and the WiFi Signal Strength .
- 2, Choose the WIFI you want to join in , Suggest choose the signal which show great or OK for better WIFI performance .
- 3,Then input the WIFI password . You can choose show password to check if the password you input is correct or not .
- 4, After then , you can click WiFi Test Button , to test if the WIFI Setting is succeed . If succeed ,it will show WiFi Test Succeed on bottom , if not will show WiFi Test Failed .
If WiFi Test Failed , you need to double check :
 - a) if the SSID password is correct
 - b) If the Antenna on WiFi Camera connected properly
 - c) if the WiFi Router working well

How Motion Detection Works?

The way that the Camera detects motion is quite straight forward - it's a process where it compares one frame with the next. A certain amount of "difference" between these two "frames" is interpreted as motion.

As a result, the Camera is able to detect when there is a change in the picture. However, this does not necessarily need to be something moving in the frame. For example, a light being turned on or off, a lightning flash or even the sun coming out momentarily on a cloudy day might be enough to trigger the motion detection on the Camera. However, as these events last only a moment (and are relatively rare) they will only create a few redundant clips, which will not take up too much space or pose a problem with scanning through footage.

For this reason, **don't use PTZ systems and motion detection simultaneously**. The Camera will interpret the camera moving as 'motion' and record. This is particularly true when using Cruise Mode - as the camera is moving almost continuously, so too is the Camera recording almost continuously!

Here, you'll be able to set the motion detection features of the Camera for each channel. We suggest that motion detection, under most circumstances, is the most practical recording method for the Camera to employ.

How it Works: Once motion detection has been enabled for a channel, it will register to the Camera as a **Motion Event**. Thus, you can use the Motion recording mode in the schedule to trigger the Camera to record when motion detection triggers an alarm signal.

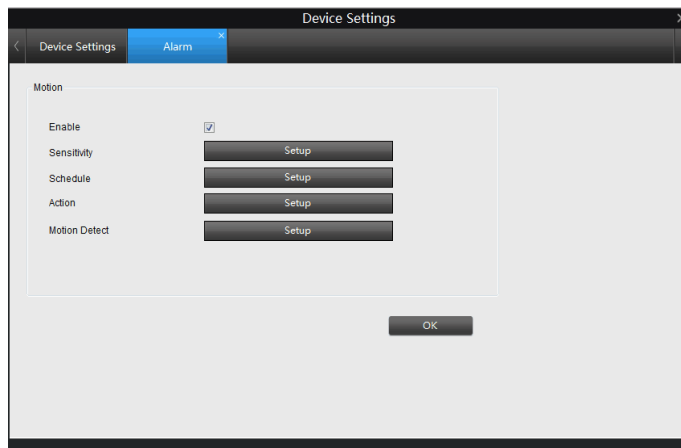

- **Enable:** Whether or not motion detection is enabled on a specific channel. Each channel can be configured independently to one another.
- **Sensitivity:** If the motion detection sensitivity is **too high**, then the Camera will record too frequently or continuously - any benefit of motion detection will be lost. If the motion detection sensitivity is too low, then the Camera will not record when it should and may not record anything at all.

Here you may set the sensitivity on different time, for example, night time sensitivity is higher and day time sensitivity is lower for frequent movement on the daytime .

- **Schedule:** you may set the motion detection schedule time here, one box means 1 hour.
- **Action:** Here you may define what will happen when the camera you've selected detects motion. You may enable Audio Warning, and send e-mail when motion happens .

Note: If you've used the Copy-To feature to copy from one camera to another, remember that you still need to set the *Action* for each channel independently - that information isn't copied

- **Motion Detect Setup:**

- **Full Screen:** Setting the motion detection area, you may drag the box to un-choose the area. For example , you can using the grid to cover your front door, so your front door will be set as the motion detection area.
- **Clear Area :** Clear Area means no area for motion detection .

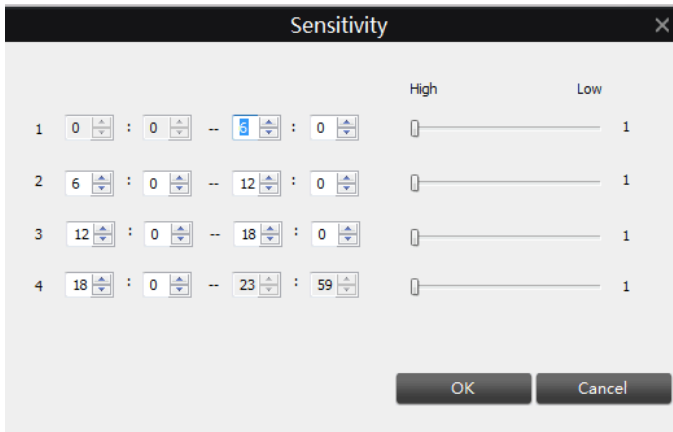

● **Sensitivity:** The Sensitivity setting is controlled by a slider, allowing you to set a value between 0 and 50. The lower the number, the more sensitive the motion detection will be. 1 is the highest sensitivity.

There are **four time periods** which you may define different motion sensitivity values.

You may change each period's start and end time to best match the changing lighting conditions in your location.

values between 5 - 10 will give good results in the daytime.

At night, you may get numerous false triggers unless you raise the sensitivity setting, perhaps

as high as 25 - 30. This is because when cameras use active infrared night vision, they dramatically increase the gain controls to the image sensor. This creates a level of "noise" in the camera's images, which are interpreted by the Camera as motion.

By default, the day is divided into four periods:

- 00:00 (Midnight) - 06:00 (6:00 AM)
- 06:00 (6:00 AM) - 12:00 (Mid-day)
- 12:00 (Mid-day) - 18:00 (6:00 PM)
- 18:00 (6:00 PM) - 00:00 (Midnight)

You might need to shift the beginning and end times to best suit the lighting condition at your location.

The start and end times can be set to anything you like, provided the different time periods don't overlap and there's no gap between one ending and the next starting.

There's no requirement for all four time periods to have different sensitivity levels, although we suggest that usually gives the best performance.

To find the best sensitivity values for different times of day/ night, it's best to test the system during different time periods. Get an able-bodied volunteer to move about in front of the cameras you'd like to tune the sensitivity for. The ideal sensitivity level is when your volunteer moving about always triggers the motion detection, but there are no false triggers (or very few) when your volunteer isn't moving about.

● False Triggers

Setting the motion detection at high sensitivity levels (4 or lower) increases the frequency of false alarms. On the other hand, low sensitivity levels (20 or higher) increase the risk that a significant motion event (such as an intruder) will not trigger the motion detection to record.

Check the Motion Detection settings both during the day and night. In low-light conditions (or when your cameras are using infrared night vision) the Camera may be more or less sensitive to motion, depending on the circumstances. The difference might be very dramatic!

● Weather

The weather conditions are going to affect your motion detection. Dramatic weather phenomenon such as heavy rain, strong winds, lightning and so on, may trigger the motion detection with surprising frequency. On the other hand, things like fog, mist and other obscuring kinds of weather might mask or obscure something moving to the point that the Camera fails to detect them.

Here are a few steps you can take to minimise the amount of noise in your images.

- Try adjusting the Image Settings to fine-tune the brightness and contrast to get a more stable image.
- Limit the motion sensitive area to only the areas in view that a target could be. In particular, large featureless areas in the camera's view are the ones most likely to give false triggers - turning off the motion sensitivity to any area a target cannot move in front of will help reduce false triggers.

Note: The motion detection feature will seem more sensitive at night, particularly when using low-light or active infrared cameras. We recommend that you test your motion detection sensitivity both during the day and at night to ensure your sensitivity setting is suitable for either lighting condition.

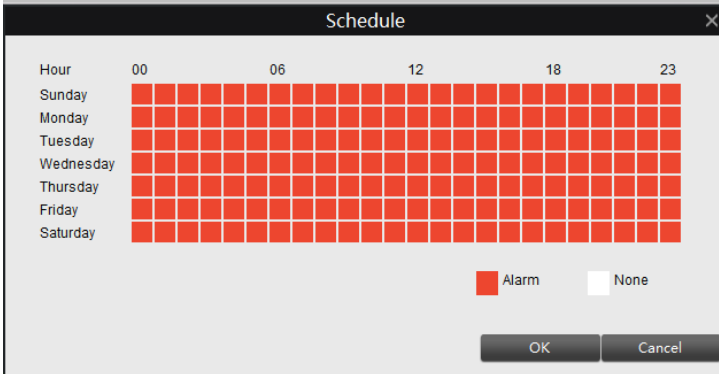

Motion Detection - Schedule

Here you may set the schedule time 7 days, 24 hours a week , red box means when motion is detected , it will trigger an alarm .

Action: The action you'd like the Camera to take when motion occurs. It is set in the same way as the Action for any other event.

Send Email: The Camera will send an auto-email alert when the event type you have selected occurs.



Click **Full Screen** , you will see a grid of white boxes. The outlined boxes mark the area that is sensitive to motion. The area without the white outlines is not sensitive to motion.

Click mouse to select and click again to de-select .

Use the mouse to move the cursor around the screen. By pressing select an area in the grid, you may toggle motion detection ON or OFF in that location.

Areas marked by white boxes will be sensitive to motion, those not marked will not be.

Click and drag to select the area you want to select or de-select.

Click **Clear Area** to clear up the motion Area .

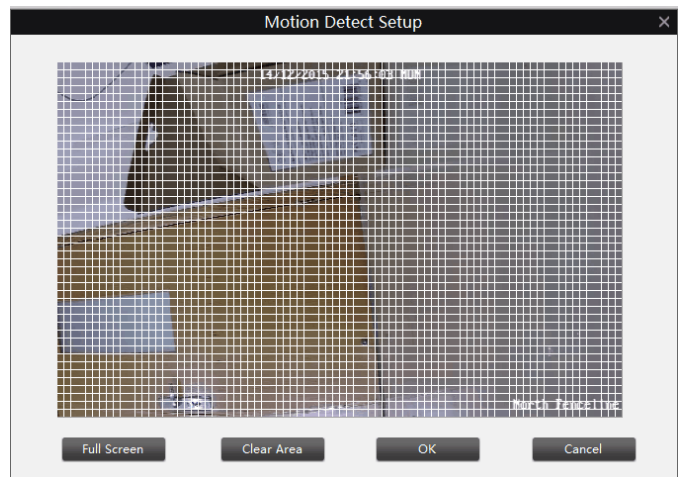



- **Video Standard:** Here you can choose between PAL and NTSC. PAL is used in Western Europe and Australia, NTSC is used in the US, Canada and Japan. If the Camera's picture is black and white, flickering or similar, then this is probably caused by the video system being set incorrectly.
- **Time Zone:** Particularly important if you have enabled NTP - set this to the time zone where you are. For example, people in eastern Australia (Canberra, Sydney and Melbourne) choose GMT+10:00, whilst the Eastern Time zone in the USA and Canada is GMT-05:00. (GMT stands for Greenwich Mean Time - it is the baseline that keeps all the different time zones in sync.)
- **Date Format:** The format of the date (eg. DD/MM/YYYY or MM/DD/YYYY and so on).
- **System Time:** This can be edited manually, or set to update automatically by using NTP.
- **Synchronize Local time :** After clicked this button, Camera time will sync with local PC time .
- **DST Setting:** As the standards for daylight savings differ from country to country, and often state to state, you might need to manually tell the Camera exactly when it commences and ends in your locality. First, turn DST on. We suggest setting the **Daylight Saving Time Mode to Date**, and manually entering the dates and times that daylight savings time applies to and from, in your locality.

Note: Some NTP servers are NOT fully compatible with DST. This may cause your system to double-count adding one or removing one more hour than they should, or cancel each other out. You may need to intentionally change your time zone to compensate, or simply not use NTP and DST simultaneously.
- **Enable Password:** When enabled, the Camera will require a password to access, even for local users. It is advisable to enable password for security.
- **Device Name:** Differentiates your Camera from other devices. If you don't have any other Camera or similar device, then you can leave this blank. If you've got multiple Cameras running on the same network, then it's a great idea to give each a unique ID.

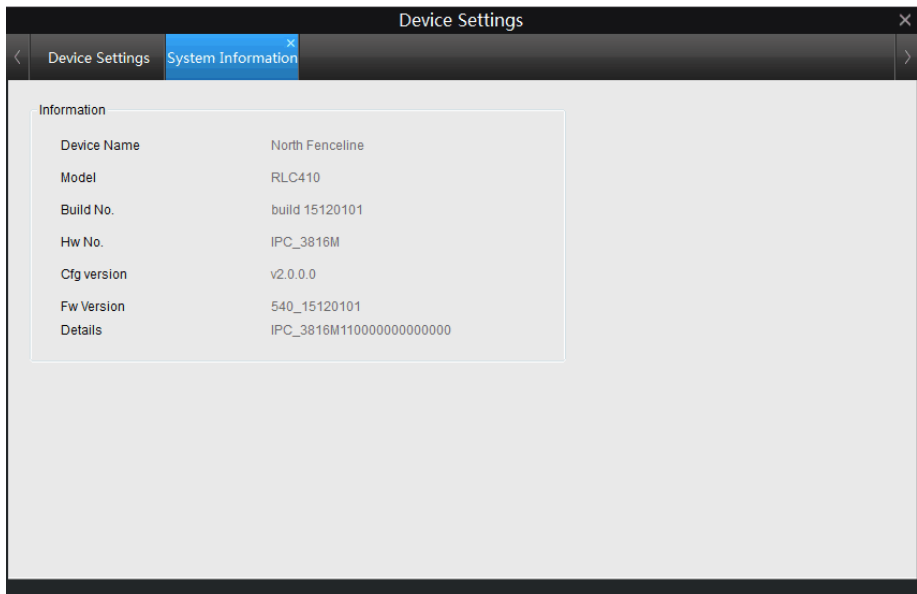

If you're looking at the System Information screen, you've probably been directed to do so by Technical Support.

If we haven't told you to come here, you might be wondering what all the information means. On a day-to-day level, the answer is "very little". However, if you're still curious:

Device Name: The name that the Camera considers to be its own, and what it will use to register an IP address with your DHCP host.

The remaining information is for use by Technical Support, in the event that you require assistance. The various model and build numbers help us track down any known issues, or catalogue new issues as they come to light. It also helps us figure out if you're running the most recent firmware on the Camera, and whether you'd benefit from an upgrade.

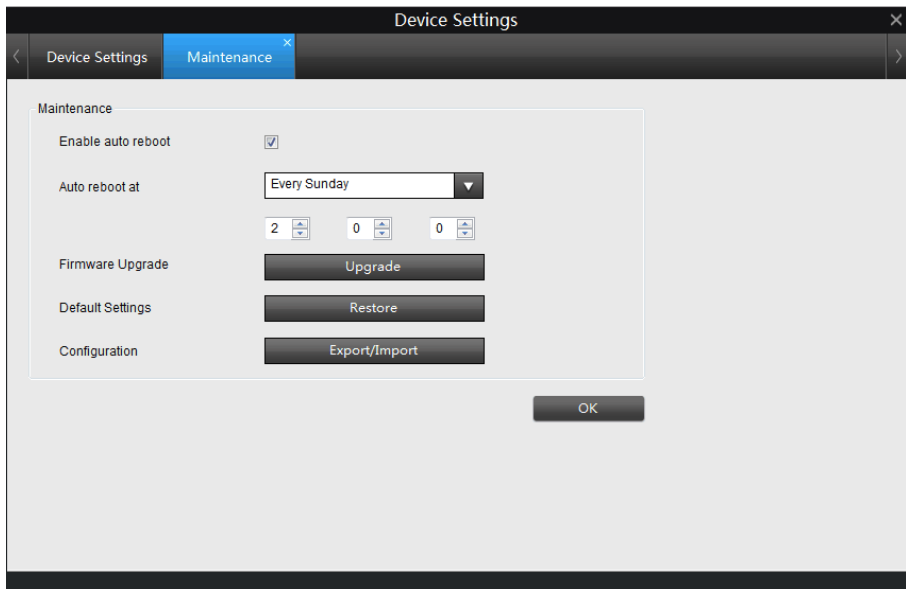

To maintain the operational integrity of the camera, it is suggested that it must be rebooted periodically. In much the same way that a computer can become unstable if left on for an extremely long time, the camera can become unstable too. It is strongly suggested that the camera be rebooted at least once per week. However, as this can be a hassle (particularly if the camera is installed away) you can set the camera to reboot itself.

- **Enable auto reboot:** Will automatically shut down and restart a camera at a certain time of the day or week.
- **Auto reboot at:** Choose when you'd like the camera to reboot. Typically, this will be a time when it's unlikely there'll be any activity for the camera to record.
- **Firmware Upgrade:** Instructs the Camera to update its firmware. You'll only need to use this option if instructed to do so by Reolink Technical Support. (Remember to Export your configuration first so you don't have to re-set everything!)
- **Default Settings:** Loads the Factory default settings.
This must be done after a firmware upgrade to ensure proper operation of the Camera. You may retain your settings, recording schedule and so on by using the Import/Export Configuration function *before* upgrading the firmware.
- **Configuration:** Creates a file containing all the settings you've customised, including your recording preferences, schedule, user-list and so on.

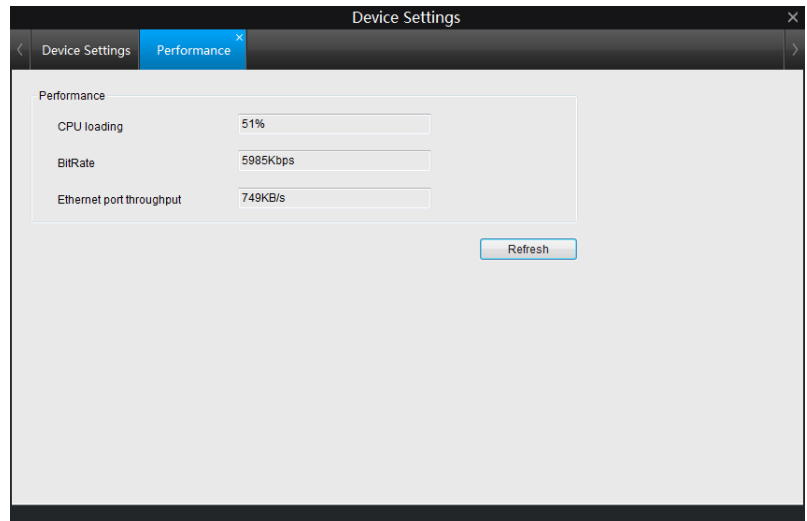

System performance page shows the CPU loading for the connected Camera , bit rate and Ethernet Port Throughout .



Reboot

If you want to shut down or reboot the camera, or simply log out of the user account you're logged in as, click on the Shutdown menu which is accessible via the Main Menu.

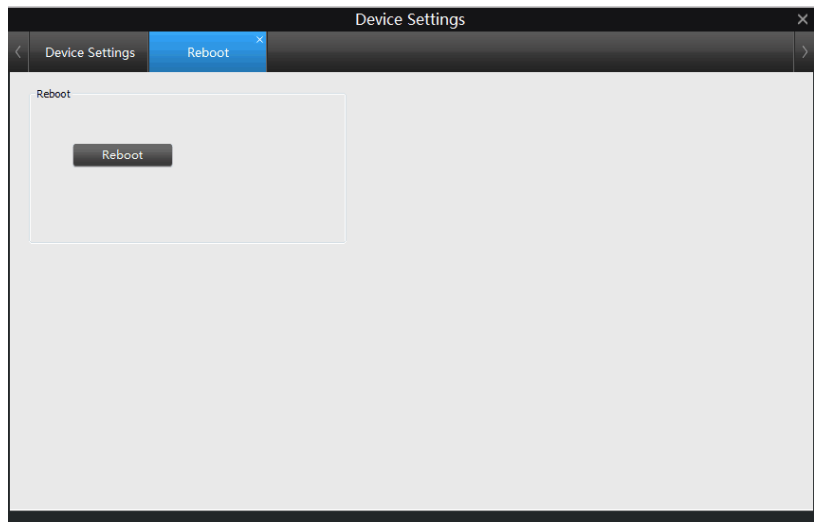

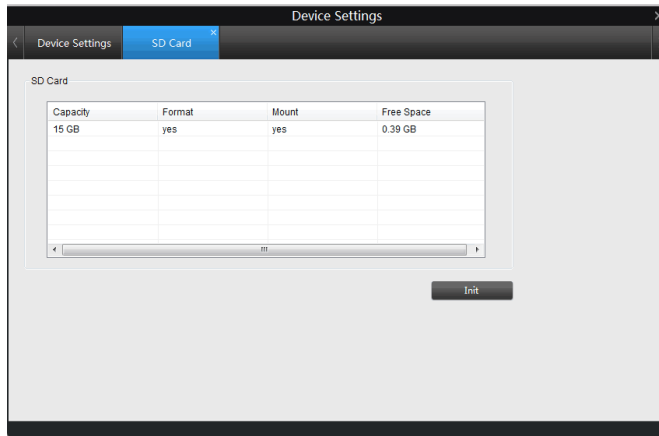

Here you can see the Micro SD card info , this function is only valid when you connect with built-in SD card devices.

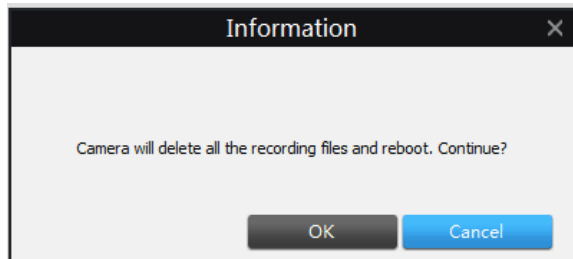

If you want to delete all the recording files from SD card , you can click Init here. Then click OK.

User -> Online User

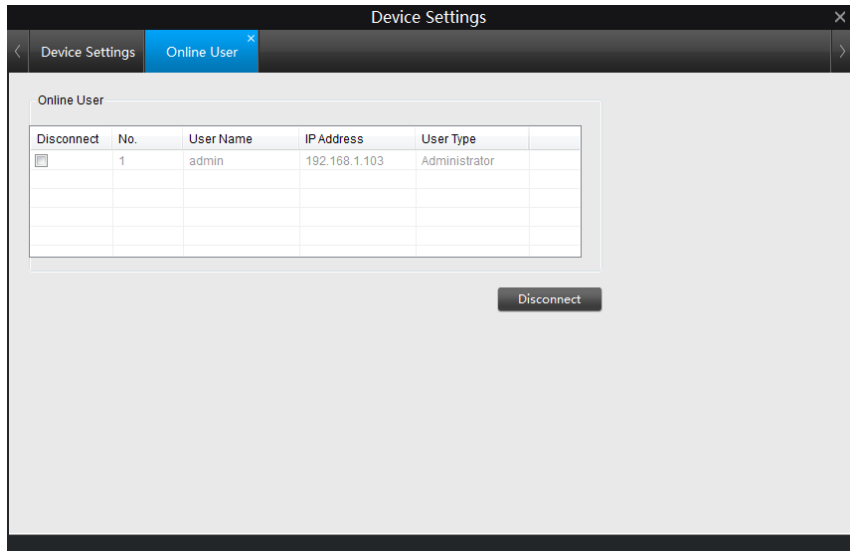

Disconnect	No.	User Name	IP Address	User Type
<input type="checkbox"/>	1	admin	192.168.1.103	Administrator

Disconnect

Here you may know how many users are online and you may disconnect the online user from viewing the camera.

User -> Add User

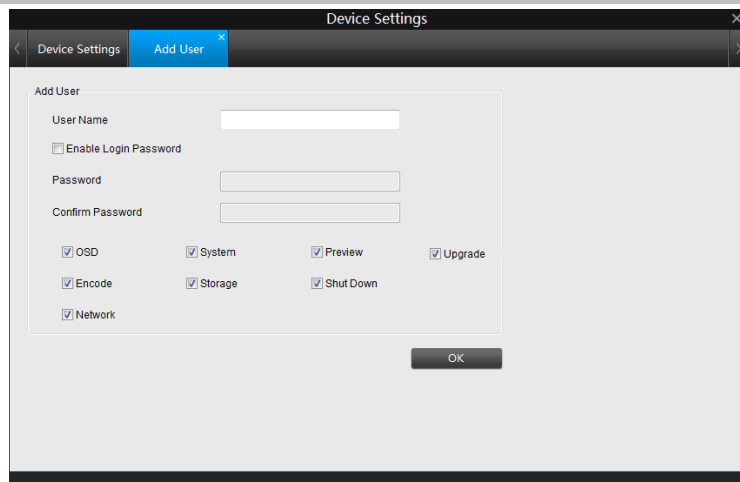

Add User

User Name

Enable Login Password

Password

Confirm Password

OSD System Preview Upgrade

Encode Storage Shut Down

Network

OK

On this page, you may add user and set the user authorities.



Device Settings

Device Settings Manage User

Manage User

No.	User Name	User Type
1	admin	Administrator

Modify Password Permission Delete User

Modify Password

User Name

Enable Login Password

Old Password

New Password

Confirm New Password

OK

Permission

User Name

Permission Configure

- OSD
- Encode
- Network
- Storage
- System
- Preview
- Shut Down
- Upgrade

OK

Here you may edit the user by modify password and set the permission authorities.

Basic Settings - OSD - Please refer to Device Setting -> Display -> Camera

Basic Settings - Encode - Please refer to Recording -> Encode

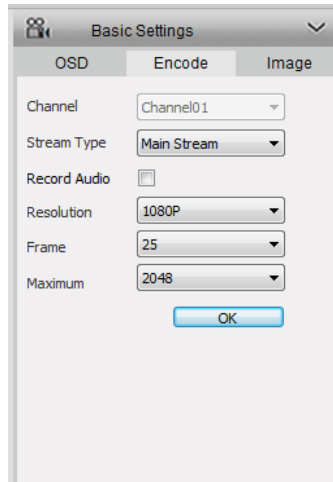
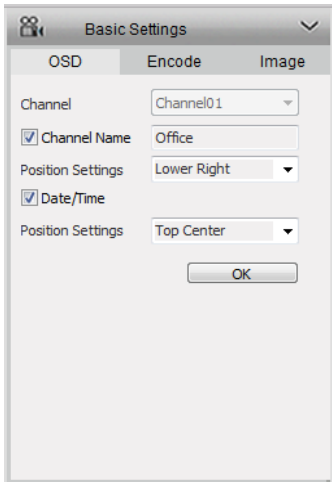

Basic Setting Image :

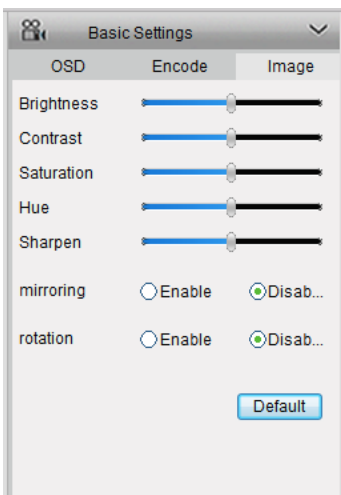

Brightness: Changes how light the image appears to be.

Contrast: Increases the difference between the blackest black and the whitest white in the image.

Saturation: Alters how much color is displayed in the image. The higher the saturation, the more bright and vivid colors will appear to be.

Hue: Changes the color mix of the image (this can have very dramatic results).

Sharpen: Sharpen image to increase the Signal Noise Ratio .

Mirroring: Change the orientation of the image to be horizontally reversed.

Rotation: Turn the image up side down.

Notice : Your image settings **will** affect your recordings!

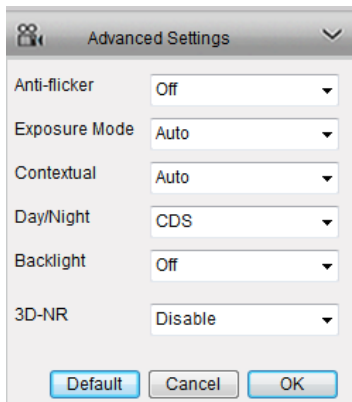

Advanced Settings: Adjust various camera settings according to the environment where the camera is installed.

- **Anti-flicker:** Use this feature if some devices such as TV screens and lights are flickering. For USA and Canada, set this to 60Hz. For Australia and the UK, set this to 50Hz. Outdoor mode is also available.
- **Exposure Mode:** Select the exposure level of the camera based on pre-defined conditions. Select Manual to adjust shutter speed and gain value of the camera manually.
- **Contextual:** Change the way the camera processes white balance to correct image colours. Auto, Day, Night or Manual (adjust the red and blue gain manually).
- **Day/Night:** Set the camera's colour mode during different times of the day and night - AGC(Auto set by image sensor, Colour (Always in Day mode), Black&White (Always in Night mode) or CDS (Auto set by light sensor).
- **Backlight:** Optimise brightness and contrast levels to compensate for differences between dark and bright objects using either BLC or WDR mode. This may improve image clarity in high contrast situations but should be tested at different times of the day and night to ensure there is no negative effect.
- **3D-NR:** 3D-Noise Ratio: if Enabled may decrease the noise of the image .

Reolink warrants this product against defects in workmanship and material for a period of One (1) year from its original purchase date. You must present your receipt as proof of purchase for warranty validation. Any unit which proves defective during the stated period will be repaired without charge for parts or labour or replaced at the sole discretion of Reolink. The end user is responsible for all freight charges incurred to send the product to Reolink's repair centre. The end user is responsible for all shipping costs incurred when shipping from and to any country other than the country of origin.

The warranty does not cover any incidental, accidental or consequential damages arising from the use of or the inability to use this product. Any costs associated with the fitting or removal of this product by a tradesman or other person or any other costs associated with its use are the responsibility of the end user. This warranty applies to the original purchaser of the product only and is not transferable to any third party. Unauthorised end user or third party modifications to any component or evidence of misuse or abuse of the device will render all warranties void.

By law some countries do not allow limitations on certain exclusions in this warranty. Where applicable by local laws, regulations and legal rights will take precedence.