

CCG15-48-D**

RELIABILITY DATA

信頼性データ

INDEX

	PAGE
1. MTBF計算値 Calculated Values of MTBF	3
2. 部品デレーティング Components Derating	5
3. 主要部品温度上昇値 Main Components Temperature Rise ΔT List	7
4. 出力デレーティング Output Derating	8
5. アブノーマル試験 Abnormal Test	10
6. ノイズシミュレート試験 Noise Simulate Test	12
7. その他試験 Other Test	14

* 試験結果は、代表データではありますが、全ての製品はほぼ同等な特性を示します。

従いまして、以下の結果は参考値とお考え願います。

Test results are typical data. Nevertheless the following results are considered to be reference data because all units have nearly the same characteristics.

1. MTBF計算値 Calculated Values of MTBF

MODEL : CCG15-48-12D

(1) 算出方法 Calculating Method

Telcordiaの部品ストレス解析法(*1)で算出されています。

故障率 λ_{ss} は、それぞれの部品ごとに電気ストレスと動作温度によって決定されます。

Calculated based on parts stress reliability prediction of Telcordia(*1).

Individual failure rate λ_{ss} is calculated by the electric stress and temperature rise of the each device.

*1: Telcordia document “Reliability Prediction Procedure for Electronic Equipment”
(Document number SR-332,Issue3)

$$\text{<算出式>} \quad MTBF = \frac{1}{\lambda_{equip}} = \frac{1}{\pi_E \sum_{i=1}^m N_i \cdot \lambda_{ssi}} \times 10^9 \quad \text{時間 (hours)}$$

$$\lambda_{ssi} = \lambda_{Gi} \cdot \pi_{Qi} \cdot \pi_{Si} \cdot \pi_{Ti}$$

λ_{equip} : 全機器故障率 (FITs)
Total Equipment failure rate (FITs = Failures in 10⁹ hours)

λ_{Gi} : i番目の部品に対する基礎故障率
Generic failure rate for the ith device

π_{Qi} : i番目の部品に対する品質ファクタ
Quality factor for the ith device

π_{Si} : i番目の部品に対するストレスファクタ
Stress factor for the ith device

π_{Ti} : i番目の部品に対する温度ファクタ
Temperature factor for the ith device

m : 異なる部品の数
Number of different device types

N_i : i番目の部品の個数
Quantity of ith device type

π_E : 機器の環境ファクタ
Equipment environmental factor

(2) MTBF値 MTBF Values

条件 Conditions

・入力電圧 : 48VDC

・環境ファクタ : GF (Ground, Fixed)

Input Voltage

Environmental Factor

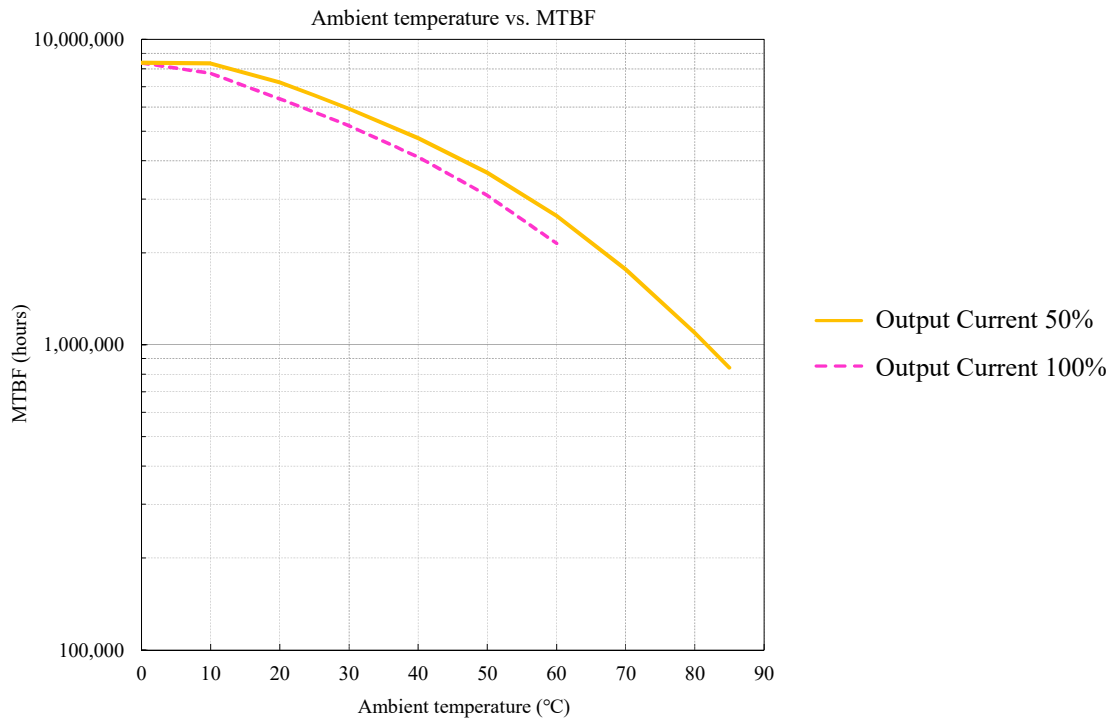

Ambient temperature	MTBF	
	Output Current 50%	Output Current 100%
25°C	6,553,752hours	5,781,772hours
40°C	4,752,811hours	4,116,588hours
60°C	2,641,914hours	2,145,007hours
85°C	841,557hours	-

2. 部品デイレートイング Components Derating

MODEL : CCG15-48-12D

(1) 算出方法 Calculating Method

(a) 測定方法 Measuring method

・入力電圧 Input Voltage	: 48VDC	・出力電流 Output Current	: 100%
・周囲温度 Ambient Temperature	: 60°C	・冷却法 Cooling	: 自然空冷 Natural convection
・取り付け Mounting	: 水平置き Horizontal		

(b) 半導体 Semiconductors

ケース温度、消費電力、熱抵抗より使用状態の接合点温度を求め最大定格、接合点温度との比較を求めました。

Compared with maximum junction temperature and actual one which is calculated based on case temperature, power dissipation and thermal impedance.

(c) IC、抵抗、コンデンサ等 IC, Resistors, Capacitors, etc.

周囲温度、使用状態、消費電力など、個々の値は設計基準内に入っています。

Ambient temperature, operating condition, power dissipation and so on are within derating criteria.

(d) 熱抵抗算出方法 Calculating method of thermal impedance

$$\theta_{j-c} = \frac{T_j(\max) - T_c}{P_j(\max)} \quad \theta_{j-a} = \frac{T_j(\max) - T_a}{P_j(\max)} \quad \theta_{j-l} = \frac{T_j(\max) - T_l}{P_j(\max)}$$

T_c : デイレートイングの始まるケース温度 一般に25°C
Case Temperature at Start Point of Derating; 25°C in General

T_a : デイレートイングの始まる周囲温度 一般に25°C
Ambient Temperature at Start Point of Derating; 25°C in General

T_l : デイレートイングの始まるリード温度 一般に25°C
Lead Temperature at Start Point of Derating; 25°C in General

$P_j(\max)$: 最大接合点(チャンネル)損失
($P_{ch}(\max)$) Maximum Junction (channel) Dissipation

$T_j(\max)$: 最大接合点(チャンネル)温度
($T_{ch}(\max)$) Maximum Junction (channel) Temperature

θ_{j-c} : 接合点(チャンネル)からケースまでの熱抵抗
(θ_{ch-c}) Thermal Impedance between Junction (channel) and Case

θ_{j-a} : 接合点から周囲までの熱抵抗
(θ_{ch-a}) Thermal Impedance between Junction (channel) and Air

θ_{j-l} : 接合点からリードまでの熱抵抗
(θ_{ch-l}) Thermal Impedance between Junction (channel) and Lead

(2) 部品デイレートイング表 Components Derating List

部品番号 Location No.	部品名 Part Name	最大定格 Maximum Rating	使用状態 Actual Rating	デイレートイング率 Derating Factor
Q1	CHIP MOS FET	Tj(max): 150°C	Tj: 87.1°C	58.1%
Q2	CHIP MOS FET	Tj(max): 150°C	Tj: 80.9°C	53.9%
D101	CHIP SBD	Tj(max): 150°C	Tj: 84.7°C	56.5%
D102	CHIP SBD	Tj(max): 150°C	Tj: 85.2°C	56.8%
A1	CHIP IC	Tj(max): 150°C	Tj: 82.2°C	54.8%
A2	CHIP IC	Tj(max): 140°C	Tj: 82.8°C	59.1%
A3	CHIP IC	Tj(max): 150°C	Tj: 81.2°C	54.1%
A4	CHIP IC	Tj(max): 150°C	Tj: 83.8°C	55.8%
A101	CHIP IC	Tj(max): 150°C	Tj: 81.7°C	54.5%
PC1	CHIP COUPLER	Tj(max): 125°C	Tj: 80.4°C	64.3%

3. 主要部品温度上昇値 Main Components Temperature Rise ΔT List

MODEL : CCG15-48-12D

(1) 測定条件 Measuring Conditions

・入力電圧 Input Voltage	: 48VDC	・出力電流 Output Current	: 100%
・周囲温度 Ambient Temperature	: 60°C	・冷却法 Cooling	: 自然空冷 Natural convection
・取り付け Mounting	: 水平置き Horizontal		

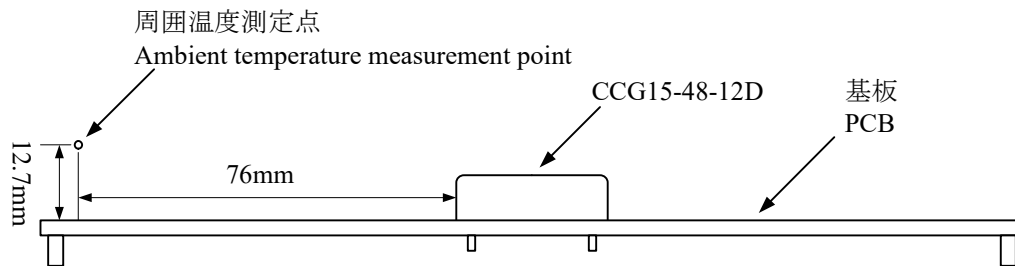

(2) 測定結果 Measuring Results

部品番号 Location No.	部品名 Part Name	温度上昇値 ΔT Temperature Rise
Q1	CHIP MOS FET	27.1°C
Q2	CHIP MOS FET	20.9°C
D101	CHIP SBD	24.7°C
D102	CHIP SBD	25.2°C
A1	CHIP IC	22.2°C
A2	CHIP IC	22.8°C
A3	CHIP IC	21.2°C
A4	CHIP IC	23.8°C
A101	CHIP IC	21.7°C
PC1	CHIP COUPLER	20.4°C
L1	CHOKE COIL	21.9°C
L101	CHOKE COIL	23.7°C
L102	CHOKE COIL	22.1°C
T1	TRANS, PULSE	30.0°C

4. 出力デレーティング Output Derating

MODEL : CCG15-48-12D, CCG15-48-15D

(1) 測定条件 Measuring Conditions

・入力電圧 Input Voltage	: 18, 24, 48, 76VDC	・冷却法 Cooling	: 自然空冷、強制空冷 Natural convection, Forced air cooling
・取り付け Mounting	: 水平置き、垂直置き Horizontal, Vertical		

(1)-1 測定方法(自然空冷、水平置き) Measuring Method(Natural convection, Horizontal)

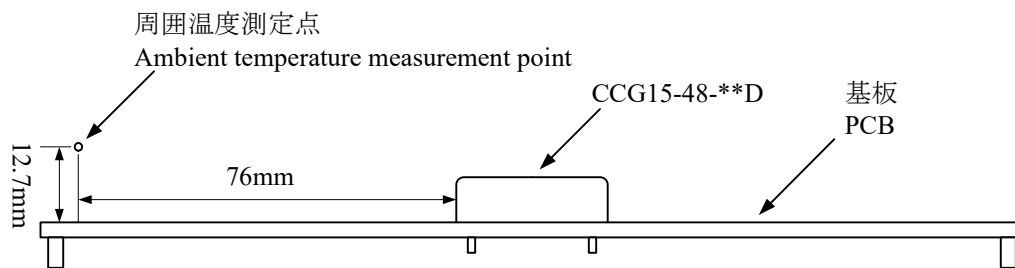

(1)-2 測定方法(強制空冷、垂直置き) Measuring Method(Forced air cooling, Vertical)

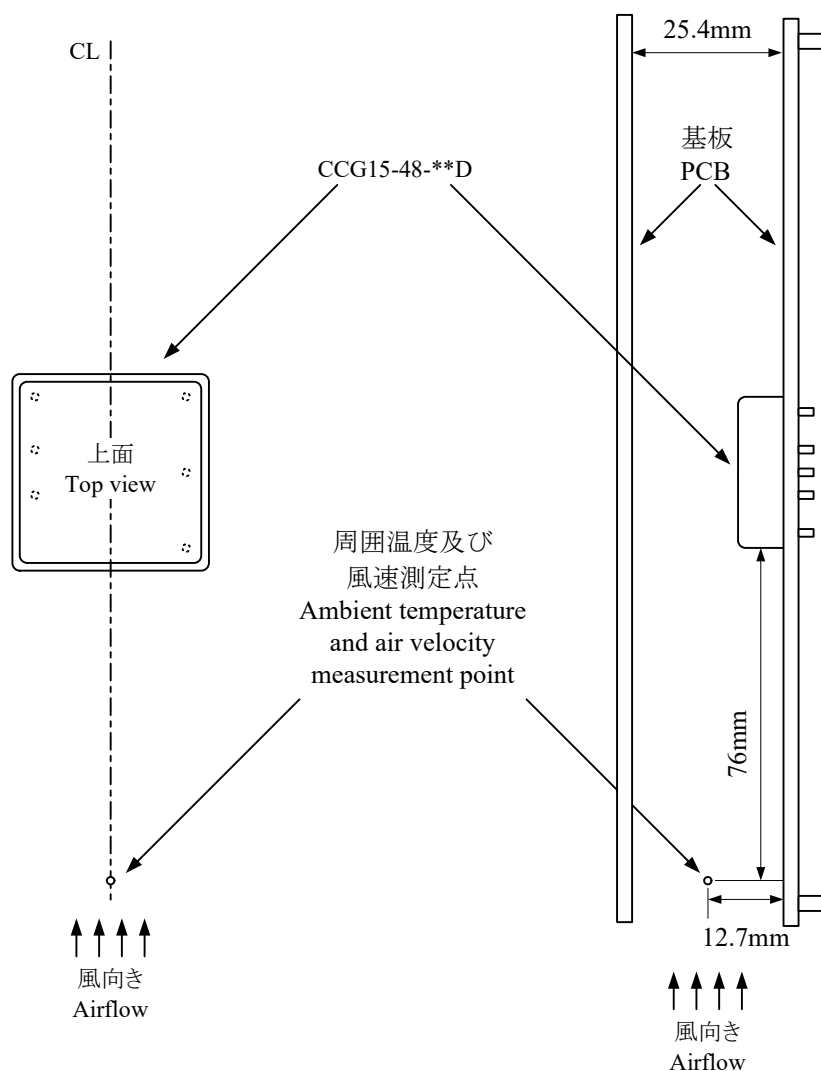

(2) 測定結果 Measuring Results

(2)-1 CCG15-48-12D

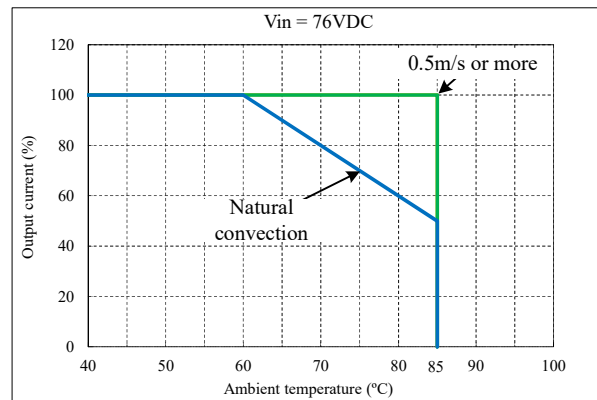
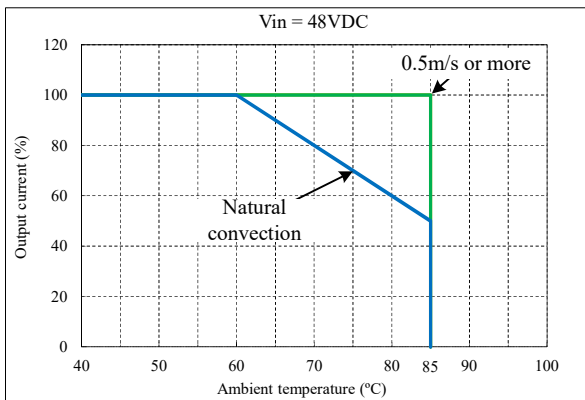
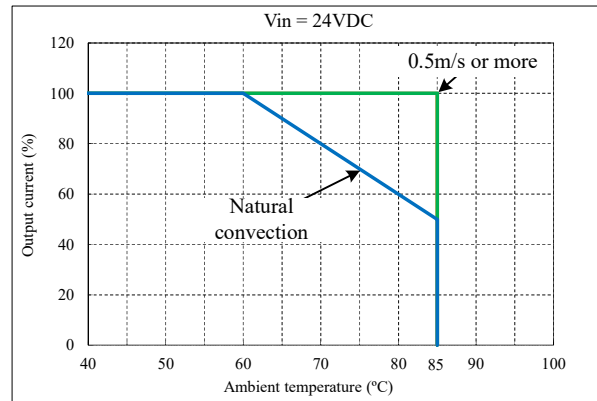
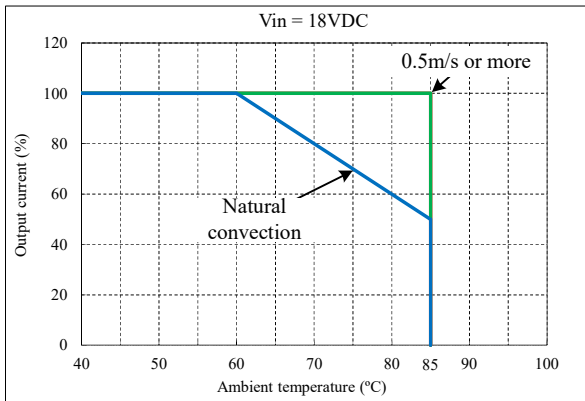

(2)-2 CCG15-48-15D

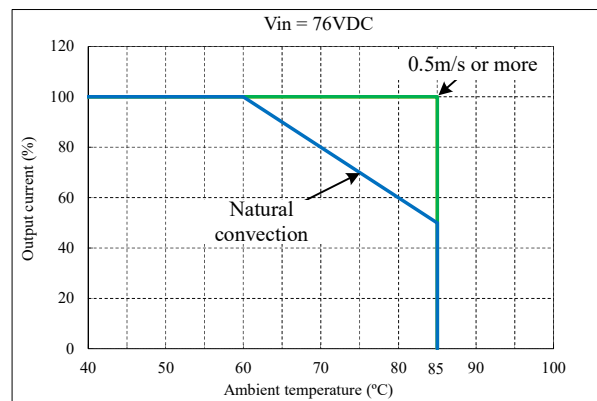
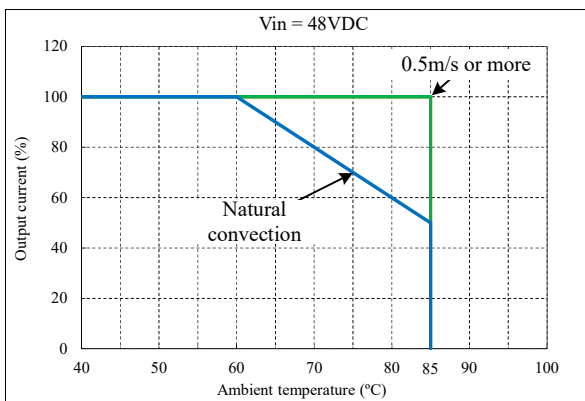
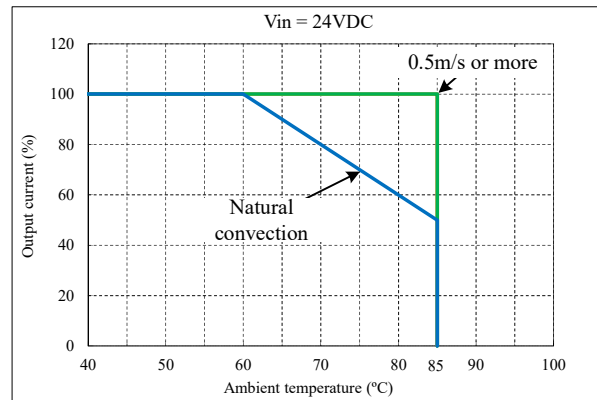
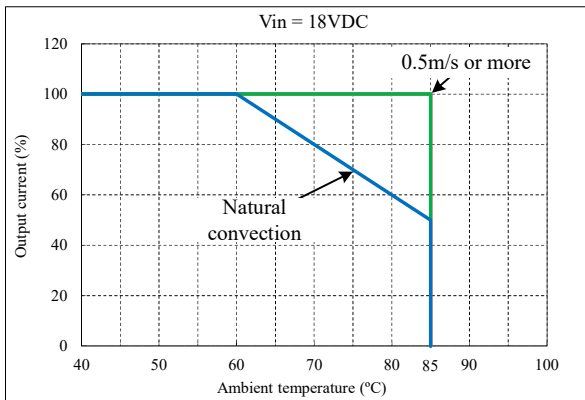

No.	Test position		Test mode		Test result											Note		
	部品No. Location No.	試験端子 Test Point	ショート Short	オープン Open	a 発火 Fire	b 発煙 Smoke	c 破裂 Burst	d 異臭 Smell	e 赤熱 Red hot	f 破損 Damaged	g ヒューズ断 Fuse blown	h O V P	i O C P	j 出力断 No output	k 変化なし No change		l その他 Others	
11	PC1	1-2	●							●			●			●	Da:D101 出力電圧増加 Output voltage increase	
12		3-4	●											●				
13		1		●						●			●				●	Da:D101 出力電圧増加 Output voltage increase
14		2		●						●			●				●	Da:D101 出力電圧増加 Output voltage increase
15		3		●						●			●				●	Da:D101 出力電圧増加 Output voltage increase
16		4		●						●			●				●	Da:D101 出力電圧増加 Output voltage increase
17	L1		●													●		
18				●														
19	L101		●													●	出力リップル増加 Output ripple increase	
20				●												●	Vo(+) $12V \Rightarrow 0V$ 、Vo(-) $12V \Rightarrow 24V$	
21	L102		●													●	出力リップル増加 Output ripple increase	
22				●												●	Vo(+) $12V \Rightarrow 24V$ 、Vo(-) $12V \Rightarrow 0V$	
23	T1	1-2	●								●		●					
24		2-3(4)	●							●	●		●				Da:Q1	
25		(3)4-5	●								●		●					
26		6-7	●										●					
27		9-10	●										●					
28		1		●													●	効率低下 Efficiency down
29		2		●													●	効率低下 Efficiency down
30		3		●													●	効率低下 Efficiency down
31		4		●													●	効率低下 Efficiency down
32		5		●													●	効率低下 Efficiency down
33		6		●													●	Vo(+) $12V \Rightarrow 24V$ 、Vo(-) $12V \Rightarrow 0V$
34		7		●													●	Vo(+) $12V \Rightarrow 0V$ 、Vo(-) $12V \Rightarrow 24V$
35		9		●													●	Vo(+) $12V \Rightarrow 24V$ 、Vo(-) $12V \Rightarrow 0V$
36		10		●													●	Vo(+) $12V \Rightarrow 0V$ 、Vo(-) $12V \Rightarrow 24V$

6. ノイズシミュレート試験 Noise Simulate Test

MODEL : CCG15-48-12D, CCG15-48-15D

(1) 使用計測器 Equipment Used

- ・ノイズシミュレーター : INS-4320A (Noise Laboratory)
Noise Simulator
- ・カップリングクランプ : CA-805B (Noise Laboratory)
Coupling Clamp

(2) 供試電源台数 The number of D.U.T. (Device Under Test)

- ・ CCG15-48-12D : 1台 (unit)
- ・ CCG15-48-15D : 1台 (unit)

(3) 試験条件 Test Conditions

- | | |
|---|--|
| ・ 入力電圧 : 48VDC
Input Voltage | ・ 出力電圧 : 定格
Output Voltage Rated |
| ・ 出力電流 : 0%、100%
Output Current | ・ 極性 : +、-
Polarity |
| ・ ノイズ電圧 : 入力ポート 0~2kV
Noise Level Input Port | ・ 印加モード : 入力ポート ノーマル
Mode Input Port Normal |
| Signal Port 0~750V | Signal Port コモン |
| Signal Port | Signal Port Common |
| ・ パルス幅 : 50~1000ns
Pulse Width | ・ トリガ選択 : Line
Trigger Select |
| ・ 周囲温度 : 25°C
Ambient Temperature | |

(4) 判定条件 Acceptable Conditions

1. 試験中、5%を超える出力電圧の変動のない事
The regulation of output voltage must not exceed 5% of initial value during test.
2. 試験後の出力電圧は初期値から変動していない事
The output voltage must be within the regulation of specification after the test.
3. 発煙・発火のない事
Smoke and fire are not allowed.

(5) 試験回路 Test Circuit

- A. 入力ポート (+Vin、-Vin) に同時に印加
Apply to input port (+Vin, -Vin) at the same time.

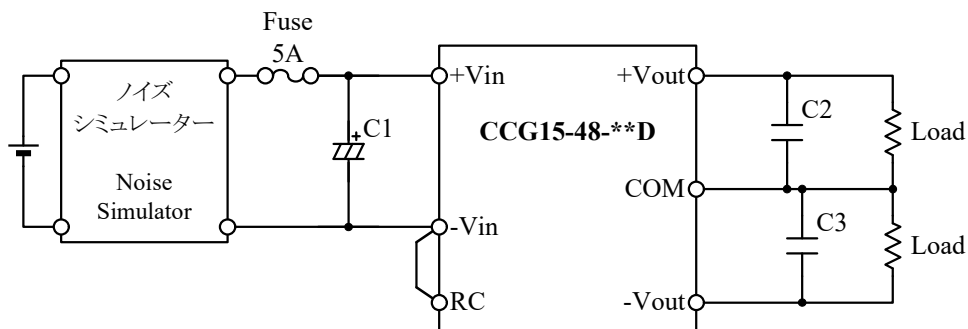

- B. 信号ポート (RC, -Vin)に印加
Apply to signal port (RC, -Vin).

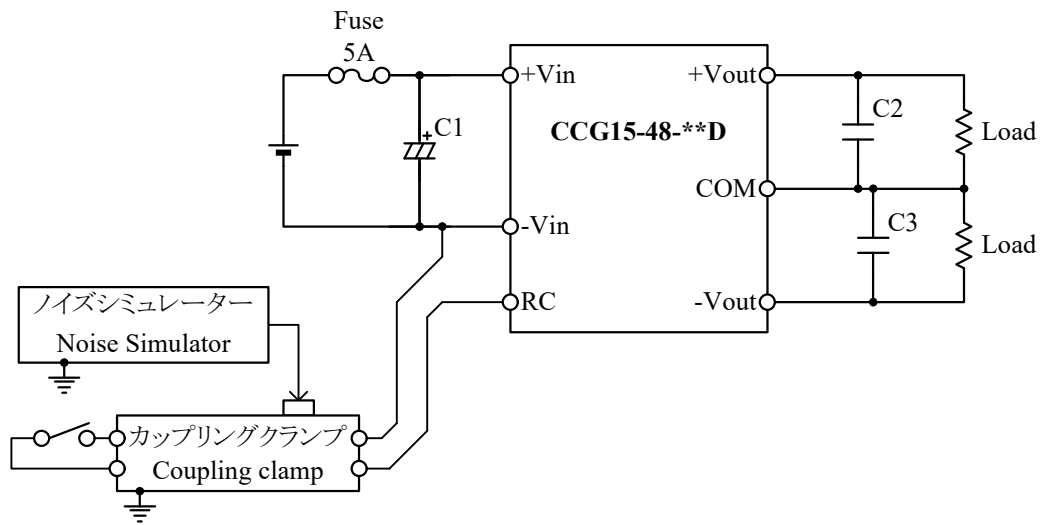

- ・電解コンデンサ(C1) : 100V 47 μ F
Electrolytic Cap.
- ・セラミックコンデンサ(C2,C3) : 25V 22 μ F
Ceramic Cap.

(6) 試験結果 Test Results

- ・ CCG15-48-12D 合格 OK
- ・ CCG15-48-15D 合格 OK

7. その他試験 Other Test

- 振動試験 Vibration Test
- はんだ耐熱性試験 Resistance to Soldering Heat Test
- 熱衝撃試験 Thermal Shock Test
- 高温加湿通電試験 High Temperature and High Humidity Bias Test

上記試験結果は、CCG15-24-***Dの信頼性データをご参照ください。

For the above test results, refer to the reliability data of CCG15-24-***D.