

Data Sheet

Reed relay 5 V/DC (2270598)

Reed relay 12 V/DC (2273680)

Features

- Epoxy molded, 4pin single-in-line packages.
- Can be immersed during board cleaning operations.
- High isolation between input and output.
- High density board mounting.
- Diode and Magnetic shield available.



Order Code

SIP - XX XX X X	a:Relay Model
a b c d e	b:Contact Form:1A=1Form,1B=1FormB
	c:Nominal Coil Voltage:05=5V,12=12V,24=24V
	d:Nil=Standard Type,D=Diode,S=Magnetic Shield ,N=Dilide+Magnetic Shield
	e:Special code:Nil=Standard Type,Y=ATE Grade
	f:Special code:Nil=Standard Type,U=Customize

Coil Data-Standard Type 1 Form A (at 20°C)

Nominal voltage DC±10%[V]	Coil Resistance ±10% (ohm)		Max. Operate Voltage (VDC)	Min. Release Voltage (VDC)	Max. Allowable Voltage (VDC)
	Standard	High-sensitivity			
5	500	1000	3.75	0.6	10
12	1000	2000	9	1	20
24	2000	—	18	2	32

Coil Data-Standard Type 1 Form B (at 20°C)

Nominal voltage DC±10%[V]	Coil Resistance ±10% (ohm)	Nominal Input Power	Max. Operate Voltage (VDC)	Min. Release Voltage (VDC)	Max. Allowable Voltage (VDC)
5	500	50mW	3.75	0.6	6
12	1000	144mW	9	1	14.5
24	2150	268mW	18	2	29

Contact Rating

Contact Form	1 Form A	1 Form B
Max. Switching Power	10W	
Max. Switching Voltage	100VDC or Peak AC	
Max. Switching Current	0.5A	
Max. Carry Current	1A	

Data Sheet

Specification

Contact Resistance	Max. 150m ohm
Operate Time (Incl. bounce)	1.0ms
Release Time	0.5ms
Insulation Resistance	1G ohm Min. (100VDC)
Dielectric Strength	Between Open Contacts 200VDC Between Coil to Contacts 1500VDC
Capacitance(between open contacts)	1.0 pF
Vibration	20G (10~2KHz)
Shock Resistance	30G (11ms, 1/2sin Wave)
Operating Temperature	-40°C ~ +85°C
Life Expectancy of Electrical	1x10 ⁸ ops (10VDC, 10mA)

Dimensions (Unit: mm)

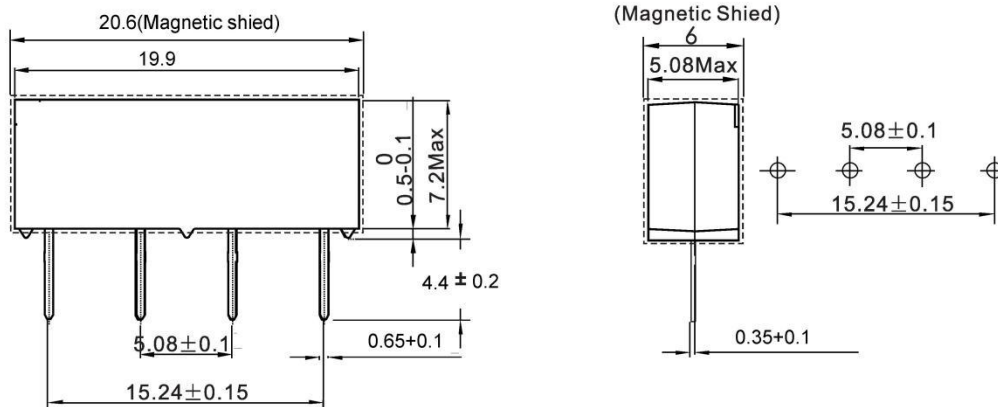

Wiring Diagrams (Bottom View)

