

SATA III 2242 M.2 SSD

# MTS400

## Datasheet

### Products

TS512GMTS400

TS256GMTS400

TS128GMTS400

TS64GMTS400

TS32GMTS400

TS16GMTS400

### Product Description

M.2 2242 SSD, SATA3 B+M Key, MLC

### Datasheet version

1.1



No.70, Xingzhong Rd., Neihu Dist., Taipei City 114, Taiwan, R.O.C.  
Tel:+886-2-2792-8000 Fax:+886-2-2792-1614  
[www.transcend-info.com](http://www.transcend-info.com)

Copyright© Transcend Information, Inc. All Rights Reserved.

 **Transcend**<sup>®</sup>

## Revision History

Revision No.	History	Released Date	Editor by
1.0	First version (WD 15nm)	2019/12/31	TSD
1.1	Vibration Format Updated Add 2.6 Recommended Measurement Point Revise 5.2.5 PS(Power shield) description Remove 5.2.9 hardware purge (Optional)	2020/05/21	TSD

# Transcend MTS400 Features

Part Name	Capacity
TS512GMTS400	512GB
TS256GMTS400	256GB
TS128GMTS400	128GB
TS64GMTS400	64GB
TS32GMTS400	32GB
TS16GMTS400	16GB

## FEATURES

- SATA 6Gbps
- 2D MLC NAND Flash
- M.2 SATA 2242 B+M Key
- DDR3 DRAM cache
- Global wear-leveling function
- Enhance Bad block management
- Power shield function
- BCH ECC function
- TRIM Command function
- Advanced Garbage Collection
- Supports S.M.A.R.T. function
- Supports DEVSLP mode
- Self-encrypting drives (SED) with AES-256 (Optional)

## PERFORMANCE<sup>1)</sup>

- Data Transfer Rate
  - Sequential Read Up to 530 MB/s
  - Sequential Write Up to 470 MB/s

## RELIABILITY<sup>1)</sup>

- TBW
  - 512GB 1,100TB
  - 256GB 740TB
  - 128GB 360TB
  - 64GB 180TB
  - 32GB 90 TB
  - 16GB 50 TB

- UBER 10<sup>-15</sup>
- DWPD 2.0 DWPD
- MTBF 2,500,000 hours
- Data Retention 1 year
- Warranty 3 years

## ENVIRONMENTAL SPECIFICATIONS<sup>1)</sup>

- Temperature
  - Operating 0°C to 70°C
  - Non-operating -40°C to 85°C
- Humidity (non-condensing) 5%~95%
- Shock 1500G, 0.5ms
- Vibration 20G, 7~2000Hz

## POWER REQUIREMENTS<sup>1)</sup>

- Supply voltage / Tolerance 3.3V±5%
- Active (max) 2.48W
- Idle (max) 0.48W

## PHYSICAL DIMENSION

- Width 22.00±0.15mm
- Length 42.00±0.15mm
- Height (max) 3.58mm
- Weight Up to 5g

**Note:** 1) For detail information, please refer to document content.

# Table of Content

<b>1 Introduction</b> .....	<b>5</b>
<b>1.1 General Feature Information</b> .....	<b>5</b>
<b>1.2 Product List</b> .....	<b>5</b>
<b>1.3 Ordering Information</b> .....	<b>6</b>
<b>2 Product Specifications</b> .....	<b>7</b>
<b>2.1 Interface and Compliance</b> .....	<b>7</b>
<b>2.2 Drive Capacity</b> .....	<b>7</b>
<b>2.3 System Performance</b> .....	<b>7</b>
<b>2.4 Supply Voltage</b> .....	<b>8</b>
<b>2.5 System Power Consumption</b> .....	<b>8</b>
<b>2.6 Environment Specifications</b> .....	<b>8</b>
<b>2.7 System Reliability</b> .....	<b>9</b>
<b>3 Mechanical Specification</b> .....	<b>11</b>
<b>4 Pin Assignment</b> .....	<b>12</b>
<b>4.1 Pin Assignments</b> .....	<b>12</b>
<b>5 Block Diagram and Function Explanations</b> .....	<b>13</b>
<b>5.1 Block Diagram</b> .....	<b>13</b>
<b>5.2 Function Explanations</b> .....	<b>13</b>
<b>6 Technology Term Explanations</b> .....	<b>16</b>
<b>6.1 TBW</b> .....	<b>16</b>
<b>6.2 DWPD</b> .....	<b>16</b>
<b>6.3 MTBF – Telcorida SR332</b> .....	<b>16</b>
<b>7 Installation Requirements</b> .....	<b>17</b>
<b>7.1 Card Insertion</b> .....	<b>17</b>
<b>8 Command Descriptions</b> .....	<b>18</b>
<b>8.1 Support ATA Commands</b> .....	<b>18</b>
<b>8.2 SMART Data Structure</b> .....	<b>20</b>
<b>8.3 SMART Attributes</b> .....	<b>21</b>
<b>9 Contact Information</b> .....	<b>22</b>

# 1. Introduction

## 1.1 General Feature Information

### Hardware Feature

- SATA 6Gbps
- Transcend Controller TS6500
- 2D MLC NAND Flash
- Temperature operation from 0°C to 70°C
- M.2 SATA 2242 B+M Key
- Embedded DDR3 DRAM cache
- Power shield function
- AES-256 function (Optional)

### Firmware Feature

- Global wear-leveling function
- Enhance Bad block management function
- BCH ECC(Error Correction Code) function
- TRIM Command function
- Advanced Garbage Collection function
- StaticDataRefresh function
- S.M.A.R.T. function
- DEVSLP mode
- TCG-Opal function (Optional)

### Software Feature

- Transcend SSD Scope Pro



TS512GMTS400

## 1.2 Product List

Form Factor	Part Name	Capacity
2242-D2-B-M	TS512GMTS400	512GB
	TS256GMTS400	256GB
	TS128GMTS400	128GB
	TS64GMTS400	64GB
	TS32GMTS400	32GB
	TS16GMTS400	16GB

## 1.3 Ordering Information

**TSXXXGMTS400**  
1            2            3            4            5

1 – Transcend

2 – SSD Density

3 – G: Gigabyte; T: Terabyte

4 – M.2 SATA device

5 – 2242 form factor

## 2. Product Specifications

### 2.1 Interface and Compliance

- SATA3, compatible to SATA2 and SATA1
- Compatible with ATA/ATAPI-7 Standard
- Native Command Queuing(NCQ) Command Set
- RoHS Compliance
- CE, FCC and BSMI Compliance

### 2.2 Drive Capacity

[Table 1] User Capacity and Addressable Sectors

	16GB	32GB	64GB	128GB
User-Addressable Sectors	31,277,232	62,533,296	125,045,424	250,069,680
Byte per Sector	512 Byte			

	256GB	512GB
User-Addressable Sectors	500,118,192	1,000,215,216
Byte per Sector	512 Byte	

### 2.3 System Performance

[Table 2] Sequence Read / Write Performance

Read / Write	16GB	32GB	64GB	128GB	256GB	512GB
Sequential Read	140 MB/s	280 MB/s	530MB/s	530MB/s	530MB/s	530MB/s
Sequential Write	26 MB/s	50 MB/s	105MB/s	200MB/s	400MB/s	470MB/s

**Note: Maximum transfer speed recorded**

1) 25°C, test on GIGABYTE GA-Z87X-D3H, 4GB, Windows® 7 Professional with AHCI mode, benchmark utility CrystalDiskMark (version 3.0.1), copied file 1000MB.

2) The recorded performance is obtained while the SSD is not operated as an OS disk Physical Specification.

[Table 3] Random Read / Write Performance

Read / Write	16GB	32GB	64GB	128GB
Random Read IOPS	14K	25K	50K	70K
Random Write IOPS	6K	10K	25K	50K

Read / Write	256GB	512GB
Random Read IOPS	70K	70K
Random Write IOPS	70K	70K

**Note: Maximum transfer speed recorded**

1) 25°C, test on GIGABYTE GA-Z87X-D3H, 4GB, Windows® 7 Professional with AHCI mode, benchmark utility IOmeter2006 with

4K file size and queue depth of 32, unit IOPs

2) The recorded performance is obtained while the SSD is not operated as an OS disk Physical Specification.

## 2.4 Supply Voltage

[Table 4] Supply Voltage

Item	Requirements
Allowable voltage	3.3V±5%
Allowable noise / ripple	100 mV p-p or less

## 2.5 System Power Consumption

[Table 5] Power Consumption

Read / Write	16GB	32GB	64GB	128GB	256GB	512GB
Active Write (Max.) <sup>1)</sup>	0.62W	0.78W	1.06W	1.52W	1.52W	2.48W
Active Read (Max.) <sup>1)</sup>	0.61W	0.73W	0.73W	0.76W	0.96W	1.58W
Idle	0.39W	0.4W	0.41W	0.41W	0.43W	0.48W
DEVSLP	5mW					

**Note:**

1) The power consumption is measured under SSD operation in maximum performance. The value is effected by system operation performance and workload.

## 2.6 Environment Specifications

[Table 6] Environment Specification

Features	Operating <sup>1)</sup>	Non-Operating <sup>2)</sup>
Temperature	0°C to +70°C	-40°C to 85°C
Temperature Gradient	60°C/Hr	60°C/Hr
Humidity	5% to 95%, non-condensing	
Shock	1500G, duration 0.5 ms, 3 axis <sup>3)</sup>	
Vibration	20G, 7~2000Hz, 3 axis <sup>4)</sup>	

**Note:**

1) The operating specification is regarded as Ambient Temperature. Standard grade (0°C to +70°C) and Industrial grade (-40°C to +85°C) indicate the temperature conditions for testing devices on programmable temperature and humidity chamber room.

2) The non-operating specification is regarded as storage specification.

3) Refer IEC 68-2-27 standard.

4) Refer IEC 68-2-6 standard.



# Recommended Measurement Point

Recommended temperature measurement point is in the center of the connector inserted by the device. Sufficient airflow is recommended for proper operation on heavier workloads within the device operating temperature.

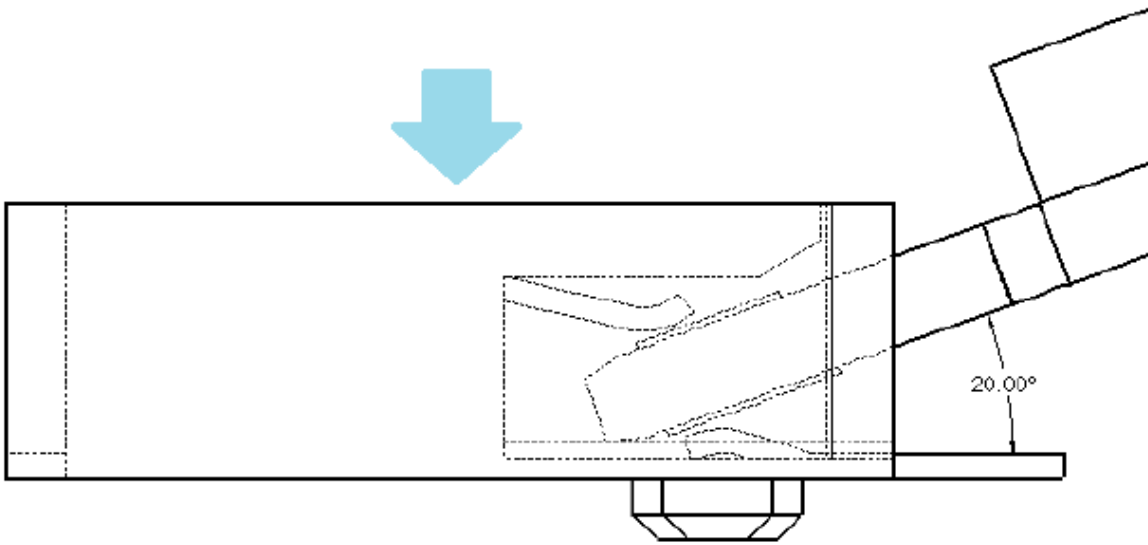

## 2.7 System Reliability

[Table 7] Telcordia SR332 issue 4 MTBF Specifications

Parameter	16GB	32GB	64GB	128GB	256GB	512GB
MTBF	2,500,000 hours					

**Note:**

1) The calculation is based on 25°C.

[Table 8] UBER Specifications

Parameter	16GB	32GB	64GB	128GB	256GB	512GB
UBER	10 <sup>-15</sup>					

**Note:**

1) Uncorrectable Bit Error Rate (UBER) is a metric for the rate of occurrence of data errors, equal to the number of data errors per bits read as specified in the JESD218 document of JEDEC standard. For the client application, JEDEC recommends that UBER shall be below 10<sup>-15</sup>.

[Table 9] TBW (Terabytes Written) Specifications

Parameter	16GB	32GB	64GB	128GB	256GB	512GB
TBW	50 TB	90 TB	180 TB	360 TB	740 TB	1,100 TB

**Note:**

1) TBW specification follows JESD219A Client workload.

[Table 10] Drive Write Per Day (DWPD) Specifications

Parameter	16GB	32GB	64GB	128GB	256GB	512GB
DWPD <sup>1)</sup>	2 (3 Years)					

**Note:**

1) DWPD is based on [Table 11] value and Warranty year to calculate.

[Table 11] Data Retention Specifications

Parameter	16GB	32GB	64GB	128GB	256GB	512GB
Data Retention	1 year					

**Note:**

1) Data retention was measured by assuming that SSD reaches the maximum rated endurance at 30°C in power-off state.

2) The data retention is defined in JESD218 Requirements for standard classes of SSDs.

[Table 12] Power On to Ready

Parameter	16GB	32GB	64GB	128GB	256GB	512GB
Setup time	0.4 s					

[Table 13] Warranty

Parameter	16GB	32GB	64GB	128GB	256GB	512GB
Warranty	3 years limited					

[Table 14] Regulations

Parameter	16GB	32GB	64GB	128GB	256GB	512GB
Compliance	CE, FCC and BSMI					

### 3. Mechanical Specification

The figure below illustrates the Transcend M.2 Type 2242-D2-B-M Solid State Drive.  
 [Table 15] Physical Dimensions and Weight

Model	Height (mm)	Width (mm)	Length (mm)	Weight (gram)
16GB/32GB/64GB/128GB/ 256GB/512GB	Max 3.58	22.00±0.15	42.00±0.15	Max 5g

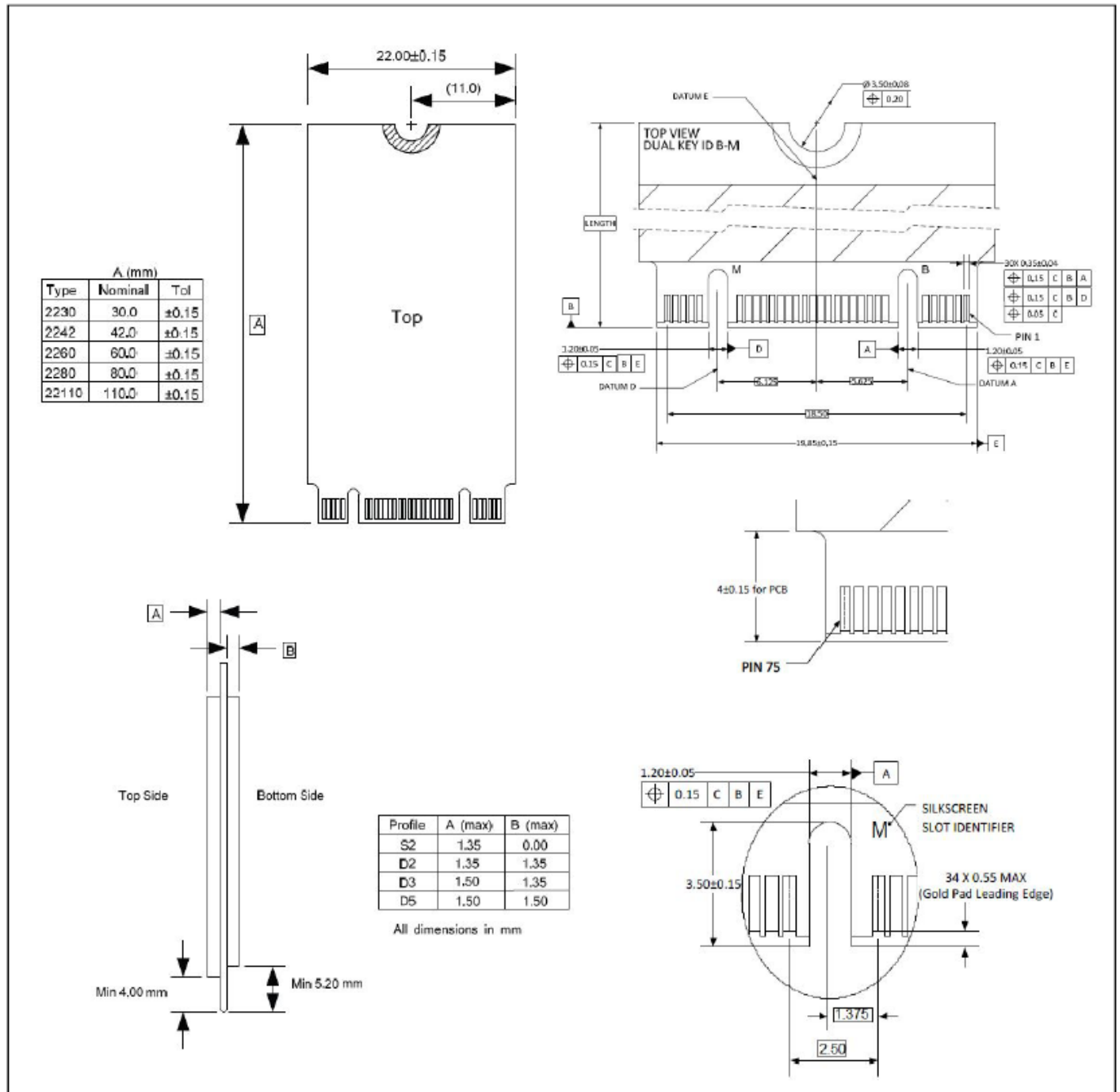

## 4. Pin Assignment

### 4.1 Pin Assignments

[Table 16] Pin Assignments

Pin No.	Pin Name	Pin No.	Pin Name	Pin No.	Pin Name	Pin No.	Pin Name
01	CONFIG_3 <sup>1)</sup>	02	3.3V	39	GND	40	NC
03	GND	04	3.3V	41	TX+	42	NC
05	NC	06	NC	43	TX-	44	NC
07	NC	08	NC	45	GND	46	NC
09	NC	10	DAS/DSS <sup>2)</sup>	47	RX-	48	NC
11	NC	12	NOTCH	49	RX+	50	NC
13	NOTCH	14	NOTCH	51	GND	52	NC
15	NOTCH	16	NOTCH	53	NC	54	NC
17	NOTCH	18	NOTCH	55	NC	56	MFG1 <sup>4)</sup>
19	NOTCH	20	NC	57	GND	58	MFG2 <sup>4)</sup>
21	CONFIG_0 <sup>1)</sup>	22	NC	59	NOTCH	60	NOTCH
23	NC	24	NC	61	NOTCH	62	NOTCH
25	NC	26	NC	63	NOTCH	64	NOTCH
27	GND	28	NC	65	NOTCH	66	NOTCH
29	NC	30	NC	67	NC	68	NC
31	NC	32	NC	69	CONFIG_1 <sup>1)</sup>	70	3.3V
33	GND	34	NC	71	GND	72	3.3V
35	NC	36	NC	73	GND	74	3.3V
37	NC	38	DEVSLP <sup>3)</sup>	75	CONFIG_2 <sup>1)</sup>		

**Note:**

- 1) For SATA M.2 SSD, these pins are connected to GND internally.
- 2) Device Activity Signal / Disable Staggered Spin-up
- 3) Device Sleep is an input pin. If driven high, the host is informing the SSD to enter a low power state.
- 4) Manufacturing pins. Do not connect.

## 5. Block Diagram and Function Explanations

### 5.1 Block Diagram

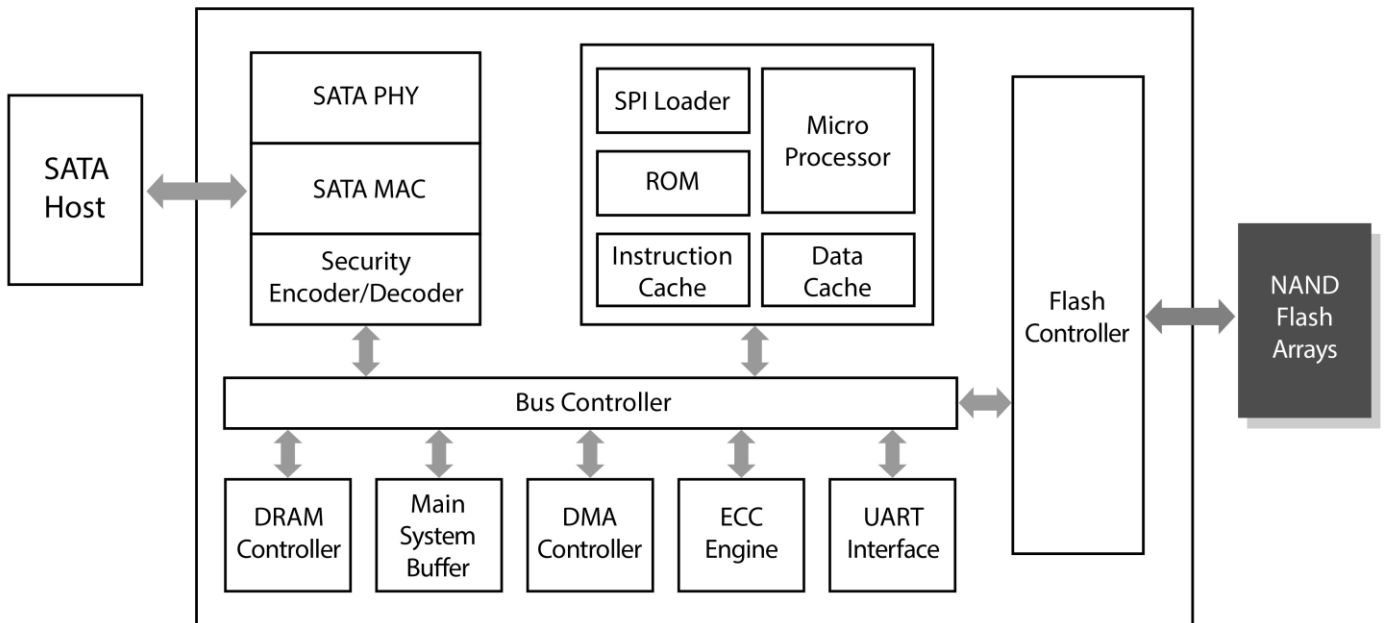

### 5.2 Function Explanations

#### 5.2.1 Global Wear Leveling Function

Global wear leveling ensures that every block has an even erase count. This helps to extend the life expectancy of an SSD.

There are three main processes in global wear leveling:

- (1) Record the block erase count and save this in the wear-leveling table.
- (2) Find the static-block and save this in the wear-leveling pointer.
- (3) Check the erase count when a block is pulled from the pool of spare blocks. If the block erase count is larger than WEARCNT, then swap the static-block and over-count-block.

#### 5.2.2 Bad Block Management Function

When the flash encounters ECC failed, program fail or erase fail, the controller will mark the block as a bad block. This will prevent the usage of bad blocks which may result in data loss in the future.

#### 5.2.3 Enhanced S.M.A.R.T. function

Transcend SSD supports S.M.A.R.T. command (Self-Monitoring, Analysis, and Reporting Technology) that allows the user to read the health information of the SSD. Transcend also define some innovated S.M.A.R.T. features which allows the user to evaluate the status of the SSD in a much more efficient way.

## 5.2.4 StaticDataRefresh Technology

Normally, ECC engine corrections are taken place without affecting the host normal operations. As time passes by, the number of error bits accumulated in the read transaction exceeds the correcting capability of the ECC engine, resulting in corrupted data being sent to the host. To prevent this, the controller monitors the error bit levels at each read operation; when it reaches the preset threshold value, the controller automatically performs data refresh to “restore” the correct charge levels in the cell. This implementation practically restores the data to its original, error-free state, and hence, lengthening the life of the data.

## 5.2.5 PS(Power shield) Function

Power Shield (PS) is a basic technology supported by all Transcend's embedded SSDs to prevent internal NAND flash data loss in event of a sudden power outage. The internal voltage detection circuit (VDT) of the controller monitors the external power supply. When the external voltage drops from 5V to 4V or from 3.3V to 2.7V, the VDT activates the PS detection mechanism. When a sudden power outage occurs, the internal power shield circuit would trigger the PS function so that the controller will stop accepting new write commands. The write operation is terminated to ensure that the firmware and the data in the NAND flash are undamaged.

When the external voltage drops to a certain level, the internal voltage detection circuit (VDT) of the controller activates the PS mechanism. The SSD controller then stops accepting new write commands from the host, ensuring the integrity of existing data for the NAND flash.

The PS function ensures the safety of the data which has already been written into the flash before sudden power outage.

## 5.2.6 DEVSLP Function

DevSlp or DevSleep (regarded as device sleep or SATA DEVSLP) is a feature in SATA SSD which allows them to go into a low power "device sleep" mode when sent the appropriate signal, which uses one or two orders of magnitude less power than a traditional idle (about 5 mW). This function can save more battery power in platform idle, so that the user can operate the platform for longer time.

## 5.2.7 AES-256 Function(Optional)

Defined by the National Institute of Standards and Technology (NIST) under the Federal Information Processing Standards Publication 197 (FIPS PUB 197), the Advanced Encryption Standard (AES) specifies a FIPS-approved cryptographic algorithm that can be used to protect electronic data.

Transcend Information's SSDs equipped with hardware-based AES-256 encryption offer superior data protection and performance compared to competing offerings that utilize software-based or firmware-based encryption. With hardware-based encryption, all data is encrypted before being stored in NAND Flash. After the encrypted data has been written into the flash, it becomes virtually impossible to decrypt the data without the original key. Performance is also improved compared to software-based solutions, since hardware-based encryption does not require system resources to perform the encryption/decryption process.

## 5.2.8 TCG-Opal Function(Optional)

Opal is a comprehensive set of guidelines. The target audience includes manufacturers of storage devices, software vendors, system integrators, and academia. These specifications cover the manufacture of storage devices, system setup, management, and use; they allow for password protection and hierarchical storage management, while preventing data from being stolen or tampered with.

They are self-encrypting devices: Data encryption is performed on the device, without need to pass through the host. The encryption key is also stored on the device (commonly AES is utilized).

(1) Features boot authentication:

When the user starts the device, the shadow MBR will conduct a pre-boot identification; where the user is cleared, the normal boot process will begin and connections to devices be made.

(2) Sector specific permissions:

The device manager may create a logical block address (LBA) range and assign different permissions for each LBA range. Only users with the correct key for a particular LBA range may perform permitted actions. Where drive locations are password-protected, only users with the correct key will be authorized entry.

## 5.2.9 Transcend SSD Scope Pro

Transcend's SSD Scope Pro is a convenient software package that helps users monitor and manage SSD status via an intuitive interface. It offers various useful features, including drive information and S.M.A.R.T. status monitoring, diagnostic scan, secure erase, health indication, system clone, and monitoring. For more information, please refer the website link. <https://us.transcend-info.com/Embedded/Essay-20>

## 5.2.10 Other Functions

Transcend SSD embedded lot of cutting-edge technology. If there is any technical request, please contact with local support team or e-mail to us.

## 6. Technology Term Explanations

### 6.1 TBW

Terabytes Written (TBW) directly measures how much you can write cumulatively into the drive over its lifetime. Essentially, it just includes the multiplication we did above in the measurement itself.

For example, if your drive is rated for 365 TBW, that means you can write 365 TB into it before you may need to replace it.

If its warranty period is 5 years, that works out to  $365 \text{ TB} \div (5 \text{ years} \times 365 \text{ days/year}) = 200 \text{ GB}$  of writes per day. If your drive was 200 GB in size, that's equivalent to 1 DWPD. Correspondingly, if your drive was rated for 3.65 PBW = 3,650 TBW, that works out to 2 TB of writes per day, or 10 DWPD.

As you can see, if you know the drive's size and warranty period, you can always get from DWPD to TBW or vice-versa with some simple multiplications or divisions. The two measurements are really very similar.

### 6.2 DWPD

Drive Writes Per Day (DWPD) measures how many times you could overwrite the drive's entire size each day of its life. For example, suppose your drive is 200 GB and its warranty period is 5 years. If its DWPD is 1, that means you can write 200 GB (its size, one time) into it every single day for the next five years.

If you multiply that out, that's  $200 \text{ GB per day} \times 365 \text{ days/year} \times 5 \text{ years} = 365 \text{ TB}$  of cumulative writes before you may need to replace it.

If its DWPD was 10 instead of 1, that would mean you can write  $10 \times 200 \text{ GB} = 2 \text{ TB}$  (its size, ten times) into it every day. Correspondingly, that's  $3,650 \text{ TB} = 3.65 \text{ PB}$  of cumulative writes over 5 years.

### 6.3 MTBF – Telcordia SR332

MTBF (mean time between failures) is a measure of how reliable a hardware product or component is. For most components, the measure is typically in thousands or even tens of thousands of hours between failures. For example, a SSD may have a mean time between failures of 200,000 hours. A desired MTBF can be used as a quantifiable objective when designing a new product. The MTBF figure can be developed as the result of intensive testing, based on actual product experience, or predicted by analyzing known factors. The manufacturer may provide it as an index of a product's or component's reliability and, in some cases, to give customers an idea of how much service to plan for. In Transcend MTBF data, we use Telcordia SR-332 Issue 4 method to do estimated calculation.



## 7. Installation Requirements

### 7.1 Card Insertion

Angles insertion is allowable and preferred; intent is to minimize the insertion/extraction force.

- Minimum of angle of insertion is 5°

Minimum two step insertion is desirable; intent is to minimize the insertion/extraction force.

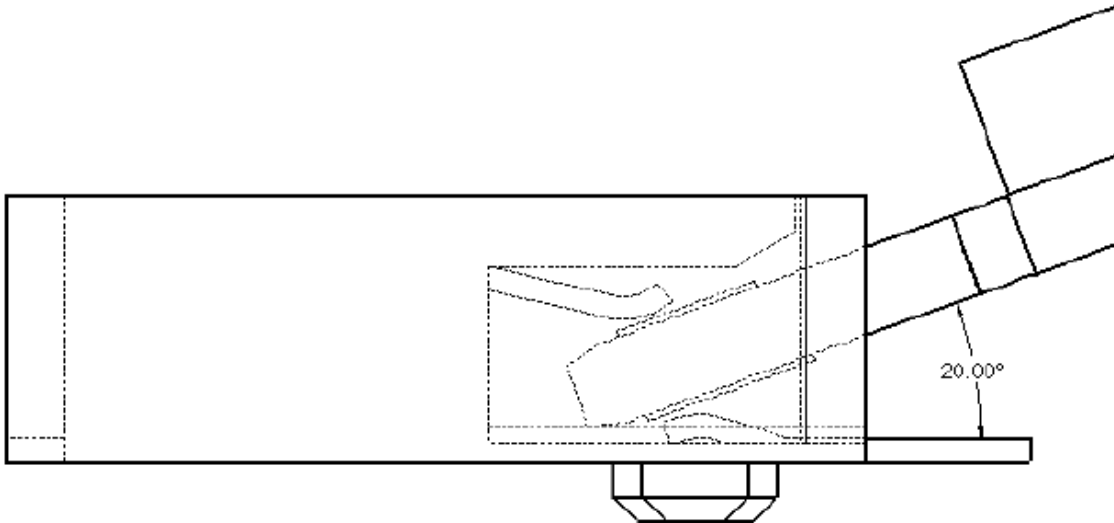

## 8. Command Descriptions

### 8.1 Support ATA Commands

This table and the following paragraphs summarize the ATA command set.

[Table 17] ATA Command Table

Support ATA/ATAPI Command	Code	Protocol
<b>General Feature Set</b>		
EXECUTE DIAGNOSTICS	90h	Device diagnostic
FLUSH CACHE	E7h	Non-data
IDENTIFY DEVICE	ECh	PIO data-In
Initialize Drive Parameters	91h	Non-data
READ DMA	C8h	DMA
READ LOG Ext	2Fh	PIO data-In
READ MULTIPLE	C4h	PIO data-In
READ SECTOR(S)	20h	PIO data-In
READ VERIFY SECTOR(S)	40h or 41h	Non-data
SET FEATURES	EFh	Non-data
SET MULTIPLE MODE	C6h	Non-data
WRITE DMA	CAh	DMA
WRITE MULTIPLE	C5h	PIO data-out
WRITE SECTOR(S)	30h	PIO data-out
NOP	00h	Non-data
READ BUFFER	E4h	PIO data-out
WRITE BUFFER	E8h	PIO data-out
<b>Power Management Feature Set</b>		
CHECK POWER MODE	E5h or 98h	Non-data
IDLE	E3h or 97h	Non-data
IDLE IMMEDIATE	E1h or 95h	Non-data
SLEEP	E6h or 99h	Non-data
STANDBY	E2h or 96h	Non-data
STANDBY IMMEDIATE	E0h or 94h	Non-data
<b>Security Mode Feature Set</b>		
SECURITY SET PASSWORD	F1h	PIO data-out
SECURITY UNLOCK	F2h	PIO data-out
SECURITY ERASE PREPARE	F3h	Non-data
SECURITY ERASE UNIT	F4h	PIO data-out
SECURITY FREEZE LOCK	F5h	Non-data
SECURITY DISABLE PASSWORD	F6h	PIO data-out
<b>SMART Feature Set</b>		
SMART Disable Operations	B0h	Non-data

SMART Enable/Disable Autosave	B0h	Non-data
SMART Enable Operations	B0h	Non-data
SMART Execute Off-Line Immediate	B0h	Non-data
SMART Read LOG	B0h	PIO data-In
SMART Read Data	B0h	PIO data-In
SMART Read THRESHOLD	B0h	PIO data-In
SMART Return Status	B0h	Non-data
SMART SAVE ATTRIBUTE VALUES	B0h	Non-data
SMART WRITE LOG	B0h	PIO data-out
<b>Host Protected Area Feature Set</b>		
Read Native Max Address	F8h	Non-data
Set Max Address	F9h	Non-data
Set Max Set Password	F9h	PIO data-out
Set Max Lock	F9h	Non-data
Set Max Freeze Lock	F9h	Non-data
Set Max Unlock	F9h	PIO data-out
<b>48-bit Address Feature Set</b>		
Flush Cache Ext	Eah	Non-data
Read Sector(s) Ext	24h	PIO data-in
Read DMA Ext	25h	DMA
Read Multiple Ext	29h	PIO data-in
Read Native Max Address Ext	27h	Non-data
Read Verify Sector(s) Ext	42h	Non-data
Set Max Address Ext	37h	Non-data
Write DMA Ext	35h	DMA
Write Multiple Ext	39h	PIO data-out
Write Sector(s) Ext	34h	PIO data-out
<b>NCQ Feature Set</b>		
Read FPDMA Queued	60h	DMA Queued
Write FPDMA Queued	61h	DMA Queued
<b>Other</b>		
Data Set Management	06h	DMA
SEEK	70h	Non-data

## 8.2 SMART Data Structure

[Table 18] SMART Data Structure

BYTE	F / V	Description
0-1	X	Revision code
2-361	X	Vendor specific
362	V	Off-line data collection status
363	X	Self-test execution status byte
364-365	V	Total time in seconds to complete off-line data collection activity
366	X	Vendor specific
367	F	Off-line data collection capability
368-369	F	SMART capability
370	F	Error logging capability 7-1 Reserved 0 1=Device error logging supported
371	X	Vendor specific
372	F	Short self-test routine recommended polling time (in minutes)
373	F	Extended self-test routine recommended polling time (in minutes)
374	F	Conveyance self-test routine recommended polling time (in minutes)
375-385	R	Reserved
386-395	F	Firmware Version/Date Code
396-397	F	Reserved
398-399	V	Reserved
400-406	V	TS6500
407-415	X	Vendor specific
416	F	Reserved
417	F	Program/write the strong page only
418-419	V	Number of spare block
420-423	V	Average Erase Count
424-510	X	Vendor specific
511	V	Data structure checksum

**Note:**

- 1) F = content (byte) is fixed and does not change.
- 2) V= content (byte) is variable and may change depending on the state of the device or the commands executed by the device.
- 3) X= content (byte) is vendor specific and may be fixed or variable.
- 4) R= content (byte) is reserved and shall be zero.

## 8.3 SMART Attributes

The following table shows the vendor specific data in byte 2 to 361 of 512-byte SMART data.

[Table 19] SMART Attributes

Attribute ID (hex)	Raw Attribute Value							Attribute Name
01	MSB	00	00	00	00	00	00	Read Error Rate
05	LSB	MSB	00	00	00	00	00	Reallocated sectors count
09	LSB	-	-	MSB	00	00	00	Power-on hours
0C	LSB	-	-	MSB	00	00	00	Power Cycle Count
A0	LSB	-	-	MSB	00	00	00	Uncorrectable sectors count when read/write
A1	LSB	MSB	00	00	00	00	00	Number of valid spare blocks
A3	LSB	MSB	00	00	00	00	00	Number of initial invalid blocks
A4	LSB	-	-	MSB	00	00	00	Total erase count
A5	LSB	-	-	MSB	00	00	00	Maximum erase count
A6	LSB	-	-	MSB	00	00	00	Minimum erase count
A7	LSB	-	-	MSB	00	00	00	Average erase count
A8	LSB	-	-	MSB	00	00	00	Max erase count of spec
A9	LSB	-	-	MSB	00	00	00	Remain Life (percentage)
AF	LSB	-	-	MSB	00	00	00	Program fail count in worst die
B0	LSB	MSB	00	00	00	00	00	Erase fail count in worst die
B1	LSB	-	-	MSB	00	00	00	Total wear level count
B2	LSB	MSB	00	00	00	00	00	Runtime invalid block count
B5	LSB	-	-	MSB	00	00	00	Total program fail count
B6	LSB	MSB	00	00	00	00	00	Total erase fail count
C0	LSB	MSB	00	00	00	00	00	Power-off retract Count
C2	MSB	00	00	00	00	00	00	Controller temperature <sup>1)</sup>
C3	LSB	-	-	MSB	00	00	00	Hardware ECC recovered
C4	LSB	-	-	MSB	00	00	00	Reallocation event count
C5	LSB	MSB	00	00	00	00	00	Current Pending Sector Count
C6	LSB	-	-	MSB	00	00	00	Uncorrectable error count off-line
C7	LSB	MSB	00	00	00	00	00	Ultra DMA CRC Error Count
E8	LSB	MSB	00	00	00	00	00	Available reserved space
F1	LSB	-	-	-	-	-	MSB	Total LBA written (each write unit = 32MB)
F2	LSB	-	-	-	-	-	MSB	Total LBA read (each read unit = 32MB)
F5	LSB	-	-	-	-	-	MSB	Flash write sector count

**Note:**

1) Controller temperature is only presented as a positive value.

## 9. Contact Information

### TAIWAN

No.70, XingZhong Rd., NeiHu Dist., Taipei, Taiwan,  
R.O.C

TEL +886-2-2792-8000

Fax +886-2-2793-2222

E-mail: [sales-tw@transcend-info.com](mailto:sales-tw@transcend-info.com)

### Shanghai

E-mail: [sales-cn@transcendchina.com](mailto:sales-cn@transcendchina.com)

TEL: +86-21-6161-9388

### Beijing

E-mail: [sales-cn@transcendchina.com](mailto:sales-cn@transcendchina.com)

TEL: +86-10-8265-9969

### Shenzhen

E-mail: [sales-cn@transcendchina.com](mailto:sales-cn@transcendchina.com)

TEL: +86-755-2598-7200

### Hong Kong

E-mail: [sales-hk@transcend-info.com](mailto:sales-hk@transcend-info.com)

TEL: +852-2331-8929

### Los Angeles

E-mail: [sales-us@transcend-info.com](mailto:sales-us@transcend-info.com)

TEL: +1-714-921-2000

### Maryland

E-mail: [sales-us@transcend-info.com](mailto:sales-us@transcend-info.com)

TEL: +1-410-689-4900

### Silicon Valley

E-mail: [sales-us@transcend-info.com](mailto:sales-us@transcend-info.com)

TEL: +1-408-785-5990

### JAPAN

E-mail: [sales-jp@transcend-info.com](mailto:sales-jp@transcend-info.com)

TEL: +81-3-5820-6000

### KOREA

E-mail: [sales-kr@transcend-info.com](mailto:sales-kr@transcend-info.com)

TEL: +82-2-782-8088

### GERMANY

E-mail: [sales-de@transcend-info.com](mailto:sales-de@transcend-info.com)

TEL: +49-40-538-907-0

### NETHERLANDS

E-mail: [sales-nl@transcend-info.com](mailto:sales-nl@transcend-info.com)

TEL: +31-10-298-8500

### United Kingdom

E-mail: [sales-uk@transcend-info.com](mailto:sales-uk@transcend-info.com)

TEL: +44-1442-202-880