

SATA III MSATA SSD

MSA452T-I

Datasheet

Products

TS1TMSA452T-I

TS512GMSA452T-I

TS256GMSA452T-I

TS128GMSA452T-I

TS64GMSA452T-I

Product Description

mSATA SSD, SATA3, 3D TLC, PE: 3K, Wide Temp

Datasheet version

1.1



No.70, Xingzhong Rd., Neihu Dist., Taipei City 114, Taiwan, R.O.C.
Tel:+886-2-2792-8000 Fax:+886-2-2792-1614
www.transcend-info.com

Copyright© Transcend Information, Inc. All Rights Reserved.



Revision History

Revision No.	History	Released Date	Editor by
1.0	First version (WD BICS4)	2020/03/03	TSD
1.1	Vibration Format Updated Add 2.6 Recommended Measurement Point Revise 5.2.5 PS(Power shield) description Revise 5.2.9 hardware purge Revise 5.2.11 Dynamic Thrtmal Throttling	2020/05/11	TSD

Transcend MSA452T-I Features

Part Name	Capacity
TS1TMSA452T-I	1TB
TS512GMSA452T-I	512GB
TS256GMSA452T-I	256GB
TS128GMSA452T-I	128GB
TS64GMSA452T-I	64GB

FEATURES

- SATA 6Gbps
- 3D TLC NAND Flash
- Wide-temperature operation
- MO-300A form factor
- DDR3 DRAM cache
- Global wear-leveling function
- Enhance Bad block management
- Power shield function
- LDPC ECC (Error correction code) functionality
- TRIM and NCQ command function
- Advanced Garbage Collection
- Internal RAID Engine
- Supports S.M.A.R.T. Function
- Dynamic Thermal Throttling (Optional)
- Supports DEVSLP mode (Optional)
- Self-encrypting drives (SED) with AES-256 (Optional)

- UBER 10⁻¹⁵
- DWPD 1.61 DWPD
- MTBF 3,000,000 hours
- Data Retention 1 year
- Warranty 3 years

ENVIRONMENTAL SPECIFICATIONS¹⁾

- Temperature
 - Operating -40°C to 85°C
 - Non-operating -40°C to 85°C
- Humidity(non-condensing) 5%~95%
- Shock 1500G, 0.5ms
- Vibration 20G, 7~2000Hz

POWER REQUIREMENTS¹⁾

- Supply voltage / Tolerance 3.3V±5%
- Active (max) 2.4W
- Idle (max) 0.4W

PERFORMANCE¹⁾

- Data Transfer Rate
 - Sequential Read Up to 560 MB/s
 - Sequential Write Up to 520 MB/s

PHYSICAL DIMENSION

- Width 29.85±0.15 mm
- Length 50.80±0.15 mm
- Height Max 4.85mm
- Weight Max 8g

Note:

1) For detail information, please refer to document content.

RELIABILITY¹⁾

- TBW
 - 1TB 1,760TB
 - 512GB 880TB
 - 256GB 440TB
 - 128GB 220TB
 - 64GB 110TB

Table of Content

1 Introduction	5
1.1 General Feature Information	5
1.2 Product List	5
1.3 Ordering Information	6
2 Product Specifications	7
2.1 Interface and Compliance	7
2.2 Drive Capacity	7
2.3 System Performance	7
2.4 Supply Voltage	8
2.5 System Power Consumption	8
2.6 Environment Specifications	8
2.7 System Reliability	9
3 Mechanical Specification	11
4 Pin Assignments	12
4.1 mSATA Serial ATA Interface	12
4.2 Pin Assignments	12
5 Block Diagram and Function Explanations	14
5.1 Block Diagram	14
5.2 Function Explanations	14
6 Technology Term Explanations	16
6.1 TBW	17
6.2 DWPD	17
6.3 MTBF – Telcordia SR-332	17
7 Installation Requirements	18
7.1 Card Insertion	18
8 Command Descriptions	19
8.1 Support ATA Commands	19
8.2 SMART Data Structure	22
8.3 SMART Attributes	23
9 Contact Information	24

1. Introduction

1.1 General Feature Information

Hardware Feature

- SATA 6Gbps
- Controller SM2258H
- 3D TLC NAND Flash
- Wide-temperature operation from -40°C to 85°C
- MO-300A form factor
- Embedded DDR3 DRAM cache
- Power shield function
- TCG-Opal function (Optional)

Firmware Feature

- Global wear-leveling function
- Enhance Bad block management function
- LDPC ECC(Error Correction Code) function
- TRIM Command function
- Advanced Garbage Collection function
- StaticDataRefresh function
- Internal RAID Engine
- S.M.A.R.T. Function
- Dynamic Thermal Throttling (Optional)
- DEVSLP mode (Optional)
- AES-256 function (Optional)

Software Feature

- Transcend SSD Scope Pro



TS512GMSA452T-I

1.2 Product List

Form Factor	Part Name	Capacity
MO-300A	TS1TMSA452T-I	1TB
	TS512GMSA452T-I	512GB
	TS256GMSA452T-I	256GB
	TS128GMSA452T-I	128GB
	TS64GMSA452T-I	64GB

1.3 Ordering Information

T S X X X G M S A 4 5 2 T I
1 2 3 4 5 6

- 1 – Transcend
- 2 – SSD Density
- 3 – G: Gigabyte; T: Terabyte
- 4 – mSATA device
- 5 – 3D TLC NAND flash
- 6 – Wide-temperature operation

2. Product Specifications

2.1 Interface and Compliance

- SATA3, compatible to SATA2 and SATA1
- Compatible with ATA/ATAPI-7 Standard
- Native Command Queuing(NCQ) Command Set
- RoHS Compliance
- CE, FCC and BSMI Compliance

2.2 Drive Capacity

[Table 1] User Capacity and Addressable Sectors

	64GB	128GB	256GB	512GB	1TB
User-Addressable Sectors	125,045,424	250,069,680	500,118,192	1,000,215,216	2,000,409,264
Byte per Sector	512 Byte				

2.3 System Performance

[Table 2] Sequential Read / Write Performance

Read / Write	64GB	128GB	256GB	512GB	1TB
Sequential Read	400MB/s	560MB/s	560MB/s	560MB/s	560MB/s
Sequential Write	200MB/s	410MB/s	410MB/s	520MB/s	520MB/s

Note: Maximum transfer speed recorded

1) 25°C, test on acer X6620G, 4GB, Windows® 7 Professional with AHCI mode, benchmark utility CrystalDiskMark (version 5.1.2), copied file 1000MB.

2) The recorded performance is obtained while the SSD is not operated as an OS disk Physical Specification.

[Table 3] Random Read / Write Performance

Read / Write	64GB	128GB	256GB	512GB	1TB
Random Read IOPS	35K	64K	65K	90K	95K
Random Write IOPS	60K	75K	75K	85K	85K

Note: Maximum transfer speed recorded

1) 25°C, test on acer X6620G, 4GB, Windows® 7 Professional with AHCI mode, benchmark utility IOmeter2008 with 4K file size and queue depth of 32, unit IOPS

2) The recorded performance is obtained while the SSD is not operated as an OS disk Physical Specification.

2.4 Supply Voltage

[Table 4] Supply Voltage

Item	Requirements
Allowable voltage	3.3V±5%
Allowable noise / ripple	100 mV p-p or less

2.5 System Power Consumption

[Table 5] Power Consumption

Read / Write	64GB	128GB	256GB	512GB	1TB
Active Write (Max.) ¹⁾	1.8W	2.0W	2.1W	2.3W	2.4W
Active Read (Max.) ¹⁾	1.5W	1.6W	1.7W	1.9W	2.2W
Idle	0.4W	0.4W	0.4W	0.4W	0.4W
DEVSLP	5mW				

Note:

1) The power consumption is measured under SSD operation at maximum performance. The value is affected by system operation performance and workload.

2.6 Environment Specifications

[Table 6] Environment Specification

Features	Operating ¹⁾	Non-Operating ²⁾
Temperature	-40°C to 85°C	-40°C to 85°C
Temperature Gradient	60°C/Hr	60°C/Hr
Humidity	5% to 95%, non-condensing	
Shock	1500G, duration 0.5 ms, 3 axis ³⁾	
Vibration	20G, 7~2000Hz, 3 axis ⁴⁾	

Note:

1) The operating specification is regarded as Ambient Temperature. Standard grade (0°C to +70°C) and Industrial grade (-40°C to +85°C) indicate the temperature conditions for testing devices on programmable temperature and humidity chamber room.

2) The non-operating specification is regarded as storage specification.

3) Refer IEC 68-2-27 standard.

4) Refer IEC 68-2-6 standard.

Recommended Measurement Point

Recommended temperature measurement point is in the center of the connector inserted by the device. Sufficient airflow is recommended for proper operation on heavier workloads within the device operating temperature.

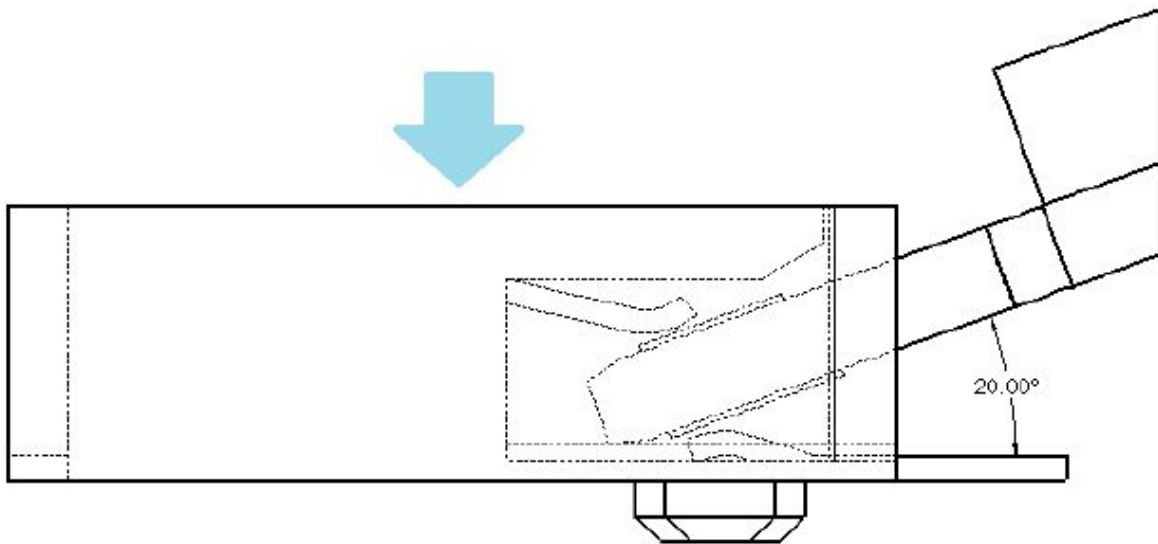

2.7 System Reliability

[Table 7] Telcordia SR332 issue 4 MTBF Specifications

Parameter	64GB	128GB	256GB	512GB	1TB
MTBF	3,000,000 hours				

Note:

1) The calculation is based on 25°C.

[Table 8] UBER Specifications

Parameter	64GB	128GB	256GB	512GB	1TB
UBER	10^{-15}				

Note:

1) Uncorrectable Bit Error Rate (UBER) is a metric for the rate of occurrence of data errors, equal to the number of data errors per bits read as specified in the JESD218 document of JEDEC standard. For the client application, JEDEC recommends that UBER shall be below 10^{-15} .

[Table 9] TBW (Terabytes Written) Specifications

Parameter	64GB	128GB	256GB	512GB	1TB
TBW	110 TB	220 TB	440 TB	880 TB	1,760 TB

Note:

1) TBW specification follows JESD219A Client workload.

[Table 10] Drive Write Per Day (DWPD) Specifications

Parameter	64GB	128GB	256GB	512GB	1TB
DWPD ¹⁾	1.61 (3 years)				

Note:

1) DWPD is based on [Table 11] value and Warranty year to calculate.

[Table 11] Data Retention Specifications

Parameter	64GB	128GB	256GB	512GB	1TB
Data Retention	1 year				

Note:

- 1) Data retention was measured by assuming that SSD reaches the maximum rated endurance at 30°C under power-off state.
- 2) The data retention is defined in JESD218 Requirements for standard classes of SSDs.

[Table 12] Power On to Ready

Parameter	64GB	128GB	256GB	512GB	1TB
Setup time	0.22 s				

[Table 13] Warranty

Parameter	64GB	128GB	256GB	512GB	1TB
Warranty	3 years limited				

[Table 14] Regulations

Parameter	64GB	128GB	256GB	512GB	1TB
Compliance	CE, FCC and BSMI				

3. Mechanical Specification

The figure below illustrates the Transcend mSATA Solid State Drive.

[Table 15] Physical Dimensions and Weight

Model	Height (mm)	Width (mm)	Length (mm)	Weight (gram)
64GB/128GB/256GB/ 512GB/1TB	Max 4.85	29.85±0.15	50.80±0.15	Max 8g

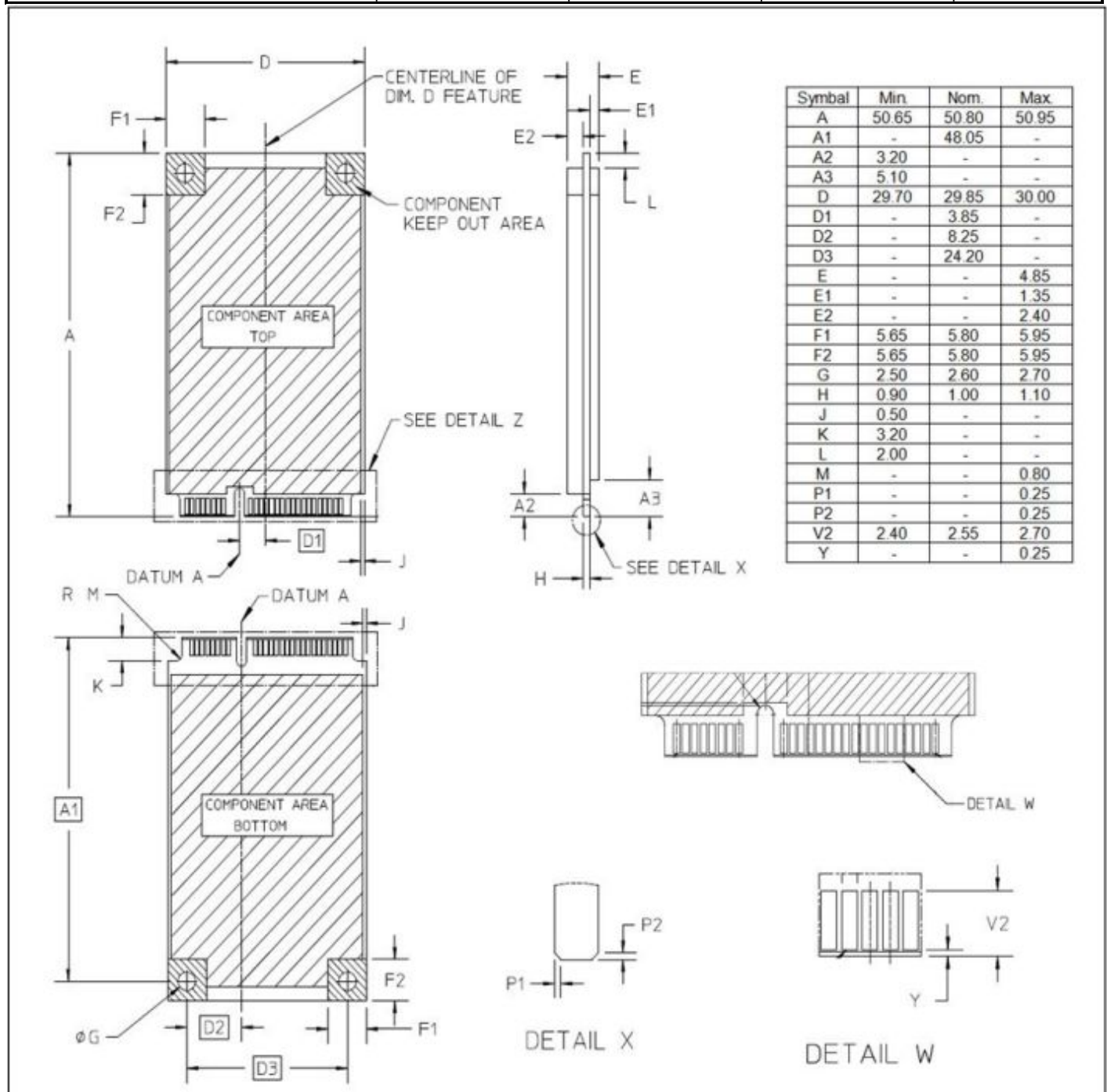

4. Pin Assignments

4.1 mSATA Serial ATA Interface

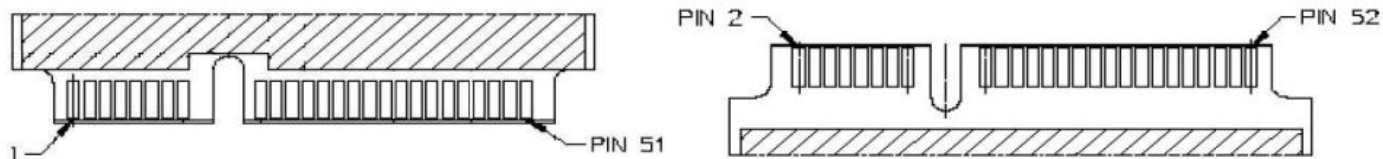

4.2 Pin Assignments

[Table 16] Pin Assignments

Pin No.	Pin Name	Pin No.	Pin Name
01	NC	02	3.3V
03	NC	04	GND ¹⁾
05	NC	06	NC
07	NC	08	NC
09	GND ¹⁾	10	NC
11	NC	12	NC
13	NC	14	NC
15	GND ¹⁾	16	NC
17	NC	18	GND ¹⁾
19	NC	20	NC
21	GND ¹⁾	22	NC
23	TX+	24	3.3V
25	TX-	26	GND ¹⁾
27	GND ¹⁾	28	NC
29	GND ¹⁾	30	NC
31	RX-	32	NC
33	RX+	34	GND ¹⁾
35	GND ¹⁾	36	NC
37	GND ¹⁾	38	NC
39	3.3V	40	GND ¹⁾
41	3.3V	42	NC
43	NC	44	DEVSLP ³⁾
45	NC	46	NC
47	NC	48	NC
49	DAS/DSS ²⁾	50	GND ¹⁾
51	Presence Detection ⁵⁾	52	3.3V

Note:

- 1) For SATA M.2 SSD, these pins are connected to GND internally.
- 2) Device Activity Signal / Disable Staggered Spin-up
- 3) DEVSLP, Device Sleep is an input pin. If driven high, the host is informing the SSD to enter a low power state. (Optional)
- 4) NC. Do not connect.
- 5) Presence Detection. This pin is connected to GND internally.

5. Block Diagram and Function Explanations

5.1 Block Diagram

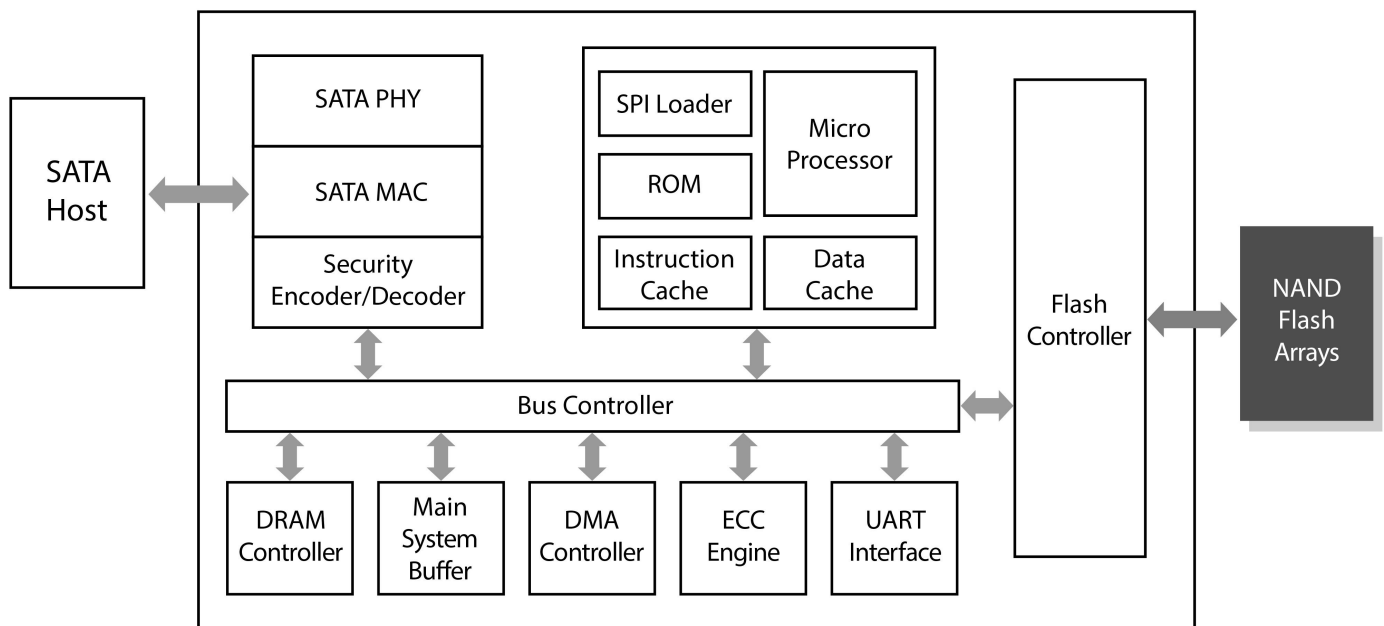

5.2 Function Explanations

5.2.1 Global Wear Leveling Function

Global wear leveling ensures that every block has an even erase count. This helps to extend the life expectancy of an SSD.

There are three main processes in global wear leveling:

- (1) Record the block erase count and save this in the wear-leveling table.
- (2) Find the static-block and save this in the wear-leveling pointer.
- (3) Check the erase count when a block is pulled from the pool of spare blocks. If the block erase count is larger than WEARCNT, then swap the static-block and the over-count-block.

5.2.2 Bad Block Management Function

When the flash encounters ECC fail, program fail or erase fail, the controller will mark the block as a bad block. This will prevent the usage of bad blocks which may result in data loss in the future.

5.2.3 Enhanced S.M.A.R.T. function

Transcend SSD supports S.M.A.R.T. command (Self-Monitoring, Analysis, and Reporting Technology) that allows users to read the health information of the SSD. Transcend also define some innovated S.M.A.R.T. features which allows the user to evaluate the status of the SSD in a much more efficient way.

5.2.4 StaticDataRefresh Technology

Normally, ECC engine corrections are taken place without affecting the host normal operations. As time passes by, the number of error bits accumulated in the read transaction exceeds the correcting capability of the ECC engine, resulting in corrupted data being sent to the host. In order to prevent such occurrence,

the controller monitors the error bit levels at each read operation; when it reaches the preset threshold value, the controller automatically performs data refresh to “restore” the correct charge levels in the cell. This implementation practically restores the data to its original, error-free state, and hence lengthening data life.

5.2.5 PS(Power shield) Function

Power Shield (PS) is a basic technology supported by all Transcend's embedded SSDs to prevent internal NAND flash data loss in event of a sudden power outage. The internal voltage detection circuit (VDT) of the controller monitors the external power supply. When the external voltage drops from 5V to 4V or from 3.3V to 2.7V, the VDT activates the PS detection mechanism. When a sudden power outage occurs, the internal power shield circuit would trigger the PS function so that the controller will stop accepting new write commands. The write operation is terminated to ensure that the firmware and the data in the NAND flash are undamaged.

When the external voltage drops to a certain level, the internal voltage detection circuit (VDT) of the controller activates the PS mechanism. The SSD controller then stops accepting new write commands from the host, ensuring the integrity of existing data for the NAND flash.

The PS function ensures the safety of the data which has already been written into the flash before sudden power outage.

5.2.6 DEVSLP Function(Optional)

DevSlp or DevSleep (regarded as device sleep or SATA DEVSLP) is a feature in SATA SSD which allows them to go into a low power "device sleep" mode when sent the appropriate signal, which uses one or two orders of magnitude less power than a traditional idle (about 5 mW). This function can help save battery power in platform idle, so that the user can operate the platform for longer time.

5.2.7 AES-256 Function(Optional)

Defined by the National Institute of Standards and Technology (NIST) under the Federal Information Processing Standards Publication 197 (FIPS PUB 197), the Advanced Encryption Standard (AES) specifies a FIPS-approved cryptographic algorithm that can be used to protect electronic data.

Transcend Information's SSDs, equipped with hardware-based AES-256 encryption, offer superior data protection and performance compared to competing offerings that utilize software-based or firmware-based encryption. With hardware-based encryption, all data are encrypted before being stored in NAND Flash. After the encrypted data has been written into the flash, it becomes virtually impossible to decrypt the data without the original key. Performance is also improved as compared to software-based solutions, since hardware-based encryption does not require system resources to perform the encryption/decryption process.

5.2.8 TCG-Opal Function(Optional)

Opal is a comprehensive set of guidelines. The target audience includes manufacturers of storage devices, software vendors, system integrators, and academia. These specifications cover the manufacture of storage devices, system setup, management, and use; they allow for password protection and hierarchical storage management, while preventing data from being stolen or tampered with.

They are self-encrypting devices: Data encryption is performed on the device, without need to pass

through the host. The encryption key is also stored on the device (commonly AES is utilized).

(1) Features boot authentication:

When the user starts the device, the shadow MBR will conduct a pre-boot identification; where the user is cleared, the normal boot process will begin and connections to the devices are to be made.

(2) Sector specific permissions:

The device manager may create a logical block address (LBA) range and assign different permissions for each LBA range. Only users with the correct key for a particular LBA range may perform permitted actions. Where drive locations are password-protected, only users with the correct key will be authorized entry.

5.2.9 Hardware-purge function(Optional)

Hardware purge is the effective, hardware-based erasure of all data blocks in flash memory, which returns the SSD to its original state at the time of manufacture. Compared to software-based methods which utilize the ATA command to erase data, hardware purge uses an external switch to adjust the voltage level from High to Low via the controller's General Purpose Input/Output. By short-circuiting the hardware purge pin, the quick erase function is activated and all data written to the SSD is fully erased. Erased data is non-recoverable, meaning that confidential information is made safe by being destroyed.

In addition to data encryption, Transcend Information offers a variety of SATA III SSD models that can be equipped with a hardware purge function to execute a quick, secure erase. The hardware purge pin is connected to the designated pin of the controller's GPIO¹. With Transcend's hardware purge feature, sensitive data can be securely, permanently erased in an effective way.

Note:

1) Customized firmware settings are required to support the hardware purge pin.

5.2.10 RAID engine

RAID engine technology stores data parity information in a specific area. The parity information can restore damaged data back which can enhance data reliability.

5.2.11 Dynamic Thermal Throttling(Optional)

For 3D TLC SSD applications, when operation temperature increases, system CLK will decrease to protect the SSD and controller with dynamic thermal throttling algorithm. The read/write speeds of the SSD will change at different temperature levels in order to extend its lifespan.

5.2.12 Transcend SSD Scope Pro

Transcend's SSD Scope Pro is a convenient software package that helps users monitor and manage SSD status via an intuitive interface. It offers various useful features, including drive information and S.M.A.R.T. status monitoring, diagnostic scan, secure erase, health indication, system clone, and monitoring. For more information, please refer the website link. <https://us.transcend-info.com/Embedded/Essay-20>

5.2.13 Other Functions

Transcend SSD embedded a lot of cutting-edge technology. Should you have any technical request, please contact the local support team or send us an e-mail.

6. Technology Term Explanations

6.1 TBW

Terabytes Written (TBW) directly measures how much you can write cumulatively into the drive over its lifetime. Essentially, it just includes the multiplication conducted above in the measurement itself.

For example, if your drive is rated for 365 TBW, that means you can write 365 TB into it before a replacement is required.

If its warranty period is 5 years, that works out to $365 \text{ TB} \div (5 \text{ years} \times 365 \text{ days/year}) = 200 \text{ GB}$ of writes per day. If your drive was 200 GB in size, that's equivalent to 1 DWPD. Correspondingly, if your drive was rated for 3.65 PBW = 3,650 TBW, that works out to 2 TB of writes per day, or 10 DWPD.

As you can see, if you know the drive's size and warranty period, you can always calculate TBW from DWPD and vice-versa with simple multiplications or divisions. The two measurements are very similar.

6.2 DWPD

Drive Writes Per Day (DWPD) measures how many times you could overwrite the drive's entire size each day of its life. For example, suppose your drive is 200 GB and its warranty period is 5 years. If its DWPD is 1, that means you can write 200 GB (its size, one time) into it every single day for the next five years.

If you multiply that out, that's $200 \text{ GB per day} \times 365 \text{ days/year} \times 5 \text{ years} = 365 \text{ TB}$ of cumulative writes before you may need to replace it.

If the DWPD is 10 instead of 1, that means you can write $10 \times 200 \text{ GB} = 2 \text{ TB}$ (its size, ten times) into it every day. Correspondingly, that's $3,650 \text{ TB} = 3.65 \text{ PB}$ of cumulative writes over 5 years.

6.3 MTBF – Telcordia SR-332

MTBF (mean time between failures) is a measure of how reliable a hardware product or component is. For most components, the measurement is typically in thousands or even tens of thousands of hours between failures. For example, a SSD may have a mean time between failures of 200,000 hours. A desired MTBF can be used as a quantifiable objective when designing a new product. The MTBF figure can be developed as the result of intensive testing, based on actual product experience, or predicted by analyzing known factors. The manufacturer may provide it as an index of a product's or component's reliability and, in some cases, to give customers an idea of how much service to plan for. In Transcend MTBF data, we use Telcordia SR-332 Issue 4 method to do estimated calculation.

7. Installation Requirements

7.1 Card Insertion

Angles insertion is allowable and preferred; the intention is to minimize the insertion/extraction force.

- Minimum of angle of insertion is 5°

Minimum two step insertion is desirable; the intention is to minimize the insertion/extraction force.

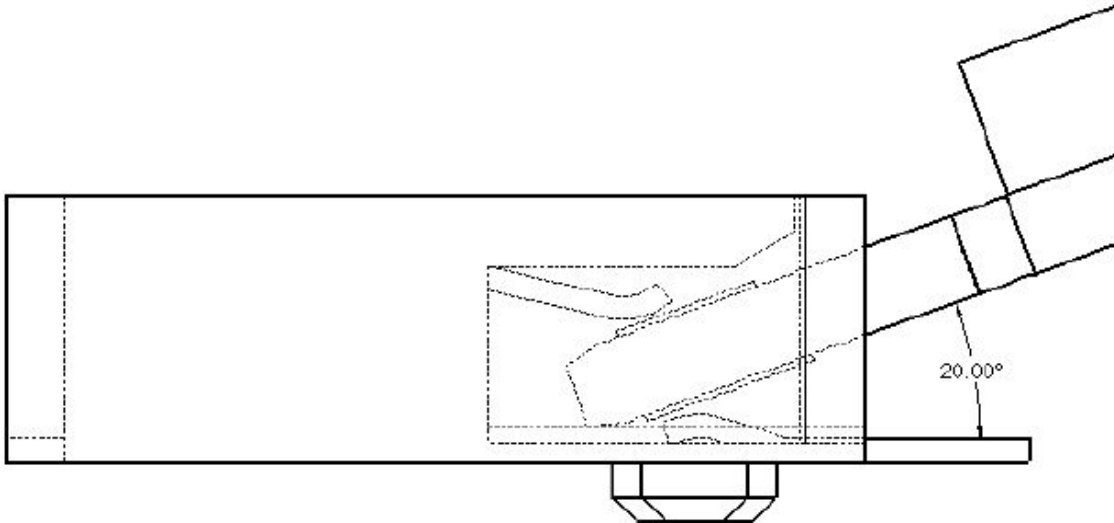

8. Command Descriptions

8.1 Support ATA Commands

This table and the following paragraphs summarize the ATA command set.

[Table 17] ATA Command Table

Support ATA/ATAPI Command	Code	Subcode / Page
NOP	00h	
Data Set Management	06h	
Trim		01h
Recalibrate	1Xh	
Read Sectors	20h	
Read Sectors (w/o retry)	21h	
Read Sectors Ext	24h	
Read DMA Ext	25h	
Read Native Max Address Ext	27h	
Read Multiple Ext	29h	
Read Log Ext	2Fh	
Log Directory		00h
Extended Comprehensive SMART Error Log		03h
Device Statistics Logs		04h
<i>List of supported log pages</i>		00h
<i>General Statistics</i>		01h
<i>General Errors Statistics</i>		04h
<i>Transport Statistics</i>		06h
<i>SSD Statistics</i>		07h
Extended SMART Self-test Log		07h
NCQ Error Log		10h
SATA Phy Event Counters Log		11h
Identify Device Data Log		30h
<i>List of Supported Pages</i>		00h
<i>Copy of IDENTIFY DEVICE Data</i>		01h
<i>Capacity</i>		02h
<i>Supported Capabilities</i>		03h
<i>Current Settings</i>		04h
<i>ATA Strings</i>		05h
<i>Security</i>		06h
<i>Serial ATA</i>		08h
Write Sectors	30h	
Write Sectors Ext	34h	
Write DMA Ext	35h	

Set Max Address Ext	37h	
Write Multiple Ext	39h	
Write DMA FUA Ext	3Dh	
Write Log Ext	3Fh	
Selective Self-Test log(SMART)		09h
Host Specific(SMART)		80h~9Fh
SCT Command/Status(SCT)		E0h
SCT Data Transfer(SCT)		E1h
Read Verify Sectors	40h	
Read Verify Sectors (w/o retry)	41h	
Read Verify Sectors Ext	42h	
Write Uncorrectable Ext	45h	
Pseudo-UECC with logging		55h
Read FPDMA Queued	60h	
Write FPDMA Queued	61h	
Seek	7Xh	
Execute Device Diagnostic	90h	
Initialize Drive Parameters	91h	
Download Microcode	92h	
Download with offsets and save microcode for immediate and future use.		03h
Download (without offsets) and save microcode		07h
Download with offsets and save microcode for future use / Activate downloaded microcode		0Eh/0Fh
SMART	B0h	
Read Data		D0h
Read Thresholds		D1h
Enable/Disable Attr Autosave		D2h
Exec Off-line Immediate		D4h
<i>Execute Off-Line routine</i>		00h
<i>Execute Short Self-test routine (Off-Line)</i>		01h
<i>Execute Extended Self-test routine (Off-Line)</i>		02h
<i>Abort Off-Line Self-test routine</i>		7Fh
<i>Execute Short Self-test routine (Captive)</i>		81h
<i>Execute Extended Self-test routine (Captive)</i>		82h
Read Log Sector		D5h
Write Log Sector		D6h
Enable Operations		D8h
Disable Operations		D9h
Return Status		Dah
Sanitize Device	B4h	

Sanitize Status Ext		00h
Block Erase Ext		12h
Sanitize Freeze Lock Ext		20h
Read Multiple	C4h	
Write Multiple	C5h	
Set Multiple Mode	C6h	
Read DMA	C8h	
Read DMA (w/o retry)	C9h	
Write DMA	CAh	
Write DMA (w/o retry)	CBh	
Write Multiple FUA Ext	CEh	
Standby Immediate	E0h	
Idle Immediate	E1h	
Standby	E2h	
Idle	E3h	
Read Buffer	E4h	
Check Power Mode	E5h	
Sleep	E6h	
Flush Cache	E7h	
Write Buffer	E8h	
Flush Cache Ext	EAh	
Identify Device	ECh	
Set Features	EFh	
Security Set Password	F1h	
Security Unlock	F2h	
Security Erase Prepare	F3h	
Security Erase Unit	F4h	
Security Freeze Lock	F5h	
Security Disable Password	F6h	
Read Native Max Address	F8h	
Set Max Address	F9h	
Set Max Set Password		01h
Set Max Lock		02h
Set Max Unlock		03h
Set Max Freeze Lock		04h
Set Max Set Password DMA		05h
Set Max Unlock DMA		06h

8.2 SMART Data Structure

[Table 18] SMART Data Structure

BYTE	F / V	Description
0-1	X	Revision code
2-361	X	Vendor specific
362	V	Off-line data collection status
363	X	Self-test execution status byte
364-365	V	Total time in seconds to complete off-line data collection activity
366	X	Vendor specific
367	F	Off-line data collection capability
368-369	F	SMART capability
370	F	Error logging capability 7-1 Reserved 0 1=Device error logging supported
371	X	Vendor specific
372	F	Short self-test routine recommended polling time (in minutes)
373	F	Extended self-test routine recommended polling time (in minutes)
374	F	Conveyance self-test routine recommended polling time (in minutes)
375-385	R	Reserved
386-395	F	Firmware Version/Date Code
396-399	F	Reserved
400-409	V	SMI2258TLC
410-510	X	Vendor specific
511	V	Data structure checksum

Note:

- 1) F = content (byte) is fixed and does not change.
- 2) V= content (byte) is variable and may change depending on the state of the device or the commands executed by the device.
- 3) X= content (byte) is vendor specific and may be fixed or variable.
- 4) R= content (byte) is reserved and shall be zero.

8.3 SMART Attributes

The following table shows the vendor specific data in byte 2 to 361 of 512-byte SMART data.

[Table 19] SMART Attributes

Attribute ID (hex)	Raw Attribute Value							Attribute Name
01	MSB	00	00	00	00	00	00	Read Error Rate
05	LSB	MSB	00	00	00	00	00	Reallocated sectors count
09	LSB	-	-	MSB	00	00	00	Power-on hours
0C	LSB	-	-	MSB	00	00	00	Power Cycle Count
94	LSB	-	-	MSB	00	00	00	SLC Total Erase Count
95	LSB	-	-	MSB	00	00	00	SLC Max Erase Count
96	LSB	-	-	MSB	00	00	00	SLC Min Erase Count
97	LSB	-	-	MSB	00	00	00	SLC Average Erase Count
9F	LSB	-	-	MSB	00	00	00	DRAM one bit error count
A0	LSB	-	-	MSB	00	00	00	Uncorrectable sectors count when read/write
A1	LSB	MSB	00	00	00	00	00	Number of valid spare blocks
A3	LSB	MSB	00	00	00	00	00	Number of initial invalid blocks
A4	LSB	-	-	MSB	00	00	00	TLC Total erase count
A5	LSB	-	-	MSB	00	00	00	TLC Maximum erase count
A6	LSB	-	-	MSB	00	00	00	TLC Minimum erase count
A7	LSB	-	-	MSB	00	00	00	TLC Average erase count
A8	LSB	-	-	MSB	00	00	00	Max erase count of spec
A9	LSB	-	-	MSB	00	00	00	Remain Life (percentage)
B1	LSB	-	-	MSB	00	00	00	Total wear level count
B5	LSB	-	-	MSB	00	00	00	Total program fail count
B6	LSB	MSB	00	00	00	00	00	Total erase fail count
C0	LSB	MSB	00	00	00	00	00	Power-off retract Count
C2	MSB	00	00	00	00	00	00	Controller temperature ¹⁾
C3	LSB	-	-	MSB	00	00	00	Hardware ECC recovered
C4	LSB	-	-	MSB	00	00	00	Reallocation event count
C7	LSB	MSB	00	00	00	00	00	Ultra DMA CRC Error Count
E8	LSB	MSB	00	00	00	00	00	Available reserved space
F1	LSB	-	-	-	-	-	MSB	Total LBA written (each write unit = 32MB)
F2	LSB	-	-	-	-	-	MSB	Total LBA read (each read unit = 32MB)
F5	LSB	-	-	-	-	-	MSB	Flash write sector count

Note:

1) Controller temperature is only presented as a positive value.

9. Contact Information

TAIWAN

No.70, XingZhong Rd., NeiHu Dist., Taipei, Taiwan,
R.O.C

TEL +886-2-2792-8000

Fax +886-2-2793-2222

E-mail: sales-tw@transcend-info.com

Shanghai

E-mail: sales-cn@transcendchina.com

TEL: +86-21-6161-9388

Beijing

E-mail: sales-cn@transcendchina.com

TEL: +86-10-8265-9969

Shenzhen

E-mail: sales-cn@transcendchina.com

TEL: +86-755-2598-7200

Hong Kong

E-mail: sales-hk@transcend-info.com

TEL: +852-2331-8929

Los Angeles

E-mail: sales-us@transcend-info.com

TEL: +1-714-921-2000

Maryland

E-mail: sales-us@transcend-info.com

TEL: +1-410-689-4900

Silicon Valley

E-mail: sales-us@transcend-info.com

TEL: +1-408-785-5990

JAPAN

E-mail: sales-jp@transcend-info.com

TEL: +81-3-5820-6000

KOREA

E-mail: sales-kr@transcend-info.com

TEL: +82-2-782-8088

GERMANY

E-mail: sales-de@transcend-info.com

TEL: +49-40-538-907-0

NETHERLANDS

E-mail: sales-nl@transcend-info.com

TEL: +31-10-298-8500

United Kingdom

E-mail: sales-uk@transcend-info.com

TEL: +44-1442-202-880