

MAIN FEATURE

1. Gold Silver alloy contact good for low switching application.
2. 2.54mm terminal pitch employment equivalent to I.C. Terminal.
3. Different types of coil sensitivity available to meet user's selection.
4. Plastic epoxy resin sealed type for washing procedure.
5. Comply with RoHS and REACH regulations.

CONTACT RATING

Item no.	2347593	2347594	2347595	2347596	2347597	2347598
Load Type	GS-SH-205D	GS-SH-212D	GS-SH-224D	GS-SH-205T	GS-SH-212T	GS-SH-224T
Relay type (category)	PCB relay	PCB relay	PCB relay	PCB relay	PCB relay	PCB relay
Certifications	UL&CUL	UL&CUL	UL&CUL	UL&CUL	UL&CUL	UL&CUL
Additional product specs	DPDT	DPDT	DPDT	DPDT	DPDT	DPDT
Coil nominal Voltage	5 V DC	12 V DC	24 V DC	5 V DC	12 V DC	24 V DC
Coil voltage rating	0.36 W	0.36 W	0.36 W	0.2 W	0.2 W	0.2 W
Colour	Black	Black	Black	Black	Black	Black
Connection (components)	Solder pins	Solder pins	Solder pins	Solder pins	Solder pins	Solder pins
Contact material	Ag-alloy	Ag-alloy	Ag-alloy	Ag-alloy	Ag-alloy	Ag-alloy
Contact type	2 change-overs	2 change-overs	2 change-overs	2 change-overs	2 change-overs	2 change-overs
Content	1 pc(s)	1 pc(s)	1 pc(s)	1 pc(s)	1 pc(s)	1 pc(s)
Control mode	monostable, 1 coil	monostable, 1 coil	monostable, 1 coil	monostable, 1 coil	monostable, 1 coil	monostable, 1 coil
Durability	1 x 10 ⁷ switching operations	1 x 10 ⁷ switching operations	1 x 10 ⁷ switching operations	1 x 10 ⁷ switching operations	1 x 10 ⁷ switching operations	1 x 10 ⁷ switching operations
Electrical lifespan	1 x 10 ⁶ cycles	1 x 10 ⁶ cycles	1 x 10 ⁶ cycles	1 x 10 ⁶ cycles	1 x 10 ⁶ cycles	1 x 10 ⁶ cycles
Fall time	4 ms	4 ms	4 ms	4 ms	4 ms	4 ms
Max. pick-up voltage	3.75 VDC	9 VDC	18 VDC	3.75 VDC	9 VDC	18 VDC
Max. temperature	80 °C	80 °C	80 °C	80 °C	80 °C	80 °C
Min. pick-up voltage	0.5 VDC	1.2 VDC	2.4 VDC	0.5 VDC	1.2 VDC	2.4 VDC
Min. temperature	-30°C	-30°C	-30°C	-30°C	-30°C	-30°C
Packaging type (components)	Tube	Tube	Tube	Tube	Tube	Tube
Product size (height)	11.5 mm	11.5 mm	11.5 mm	11.5 mm	11.5 mm	11.5 mm
Product size (length)	20.5 mm	20.5 mm	20.5 mm	20.5 mm	20.5 mm	20.5 mm
Product size (width)	10 mm	10 mm	10 mm	10 mm	10 mm	10 mm
Product type	PCB relay	PCB relay	PCB relay	PCB relay	PCB relay	PCB relay
Resistance (coil)	70 Ω	400 Ω	1600 Ω	125 Ω	720 Ω	2880 Ω
Response time	6 ms	6 ms	6 ms	8 ms	8 ms	8 ms
RoHS-compliant	Yes	Yes	Yes	Yes	Yes	Yes
Switching capacity (max.)	120VA 48 W	120VA 48 W	120VA 48 W	120VA 48 W	120VA 48 W	120VA 48 W
Switching current (max.)	2A	2A	2A	2A	2A	2A
Switching voltage (max.)	120 V AC 24 V DC	120 V AC 24 V DC	120 V AC 24 V DC	120 V AC 24 V DC	120 V AC 24 V DC	120 V AC 24 V DC
Weight	4.8 g	4.8 g	4.8 g	4.8 g	4.8 g	4.8 g

APPLICATION

Telecommunication, Domestic Appliances,
Office Machine, Audio Equipment, Remote Control, etc

PERFORMANCE (AT INITIAL VALUE)

- Contact Resistance 100mΩ Max. @100mA, 6VDC
- Operate Time GS-D 6 mSec. Max.
GS-T/L 8 mSec. Max.
- Release Time 4 mSec. Max.
- Dielectric Strength:

- Temperature Range -30 ~ +80°C
- Humidity Range 45 ~ 85% RH.
- Coil Temperature Rise 25°C Max. (D Type)
20°C Max. (T /L Type)
- Vibration:
 - Destruction 10 to 55 to 10 Hz, 0.75 mm single amplitude (1.5mm double amplitude)
 - Malfunction 10 to 55 to 10 Hz, 0.75 mm single amplitude (1.5mm double amplitude)
- Shock:
 - Destruction 1,000 m/S²
 - Malfunction 100 m/S²
- Life Expectancy:
 - Mechanical 10⁷ Operations at No

- Between Coil & Contact..... 1,000VAC at 50/60 Hz
for one minute
- Between Contacts500VAC at 50/60 Hz
for one minute
- Surge Strength 1,500V (between coil
& contact 1.2x50µSec.)
- Insulation Resistance..... 100 MegaΩ Min. at
500VDC
- Max. On/Off Switching:
Electrical6 Cycles per Minute
Mechanical 300 Cycles per Minute

- Electrical..... Load condition
10⁵ Operations at
Rated Resistive Load
- Weight About 4.8 g

SAFETY STANDARD & FILE NUMBER

- UL & C-UL E141060 (D,T only)

COIL SPECIFICATION (AT 20°C)

Coil Sensitivity	Nominal Voltage (VDC)	Nominal Current (mA)	Coil Resistance (Ω±10%)	Power Consumption (W)	Pull-In Voltage (VDC)	Drop-Out Voltage (VDC)	Maximum Allowable Voltage (VDC)
GS-SH-205D	5	71.4	70	Abt. 0.36	75% Maximum	10% Minimum	150%
GS-SH-212D	12	30.0	400				
GS-SH-224D	24	15.0	1,600				
GS-SH-205T	5	40.0	125	Abt. 0.20	75% Maximum	10% Minimum	150%
GS-SH-212T	12	16.7	720				
GS-SG-224T	24	8.3	2,880				

ORDERING INFORMATION

GS - SH - 2 12 D

Coil Sensitivity: D: Standard DC

Coil Voltage: 05: 5V, 12: 12V, 24: 24V

Number of Pole: 2: Two Poles

Type of Sealing: SH: RT III Wash Tight
GS

DIMENSION (≤ 5mm ± 0.2mm, > 5mm ± 0.3mm, the tolerance of PCB thru hole: +0.1mm)

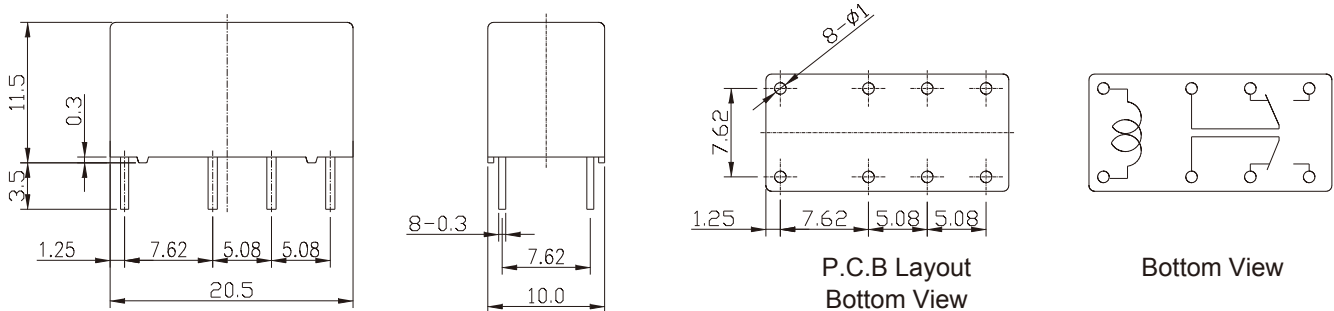

REFERENCE DATA

