



Electric Vehicle Charging Box User Manual



Enjoy it.





Content

Preface.....	A01
Safety precautions.....	A02
1. Product introduction.....	A03
2. Mechanical and electrical installation.....	A04
2.1 Internal structure diagram.....	A04
2.2 Installation.....	A04-07
3. Charging Process.....	A08-10
4. Use of card reader (RFID).....	A11-12
5. Warranty	A13

Language

A-English B-Dansk/Norsk C-Deutsch D-Nederlands
 E-Suomalainen F-Française G-Polski H-Svenska

Preface

This product is designed and manufactured according to IEC61851 and SAEJ1772 international standards.

Use limitations of the Electric Vehicle Charging box

This EV charging box is designed for use in the following conditions:

Sea level < 2000m

Surrounding Temperature -40°C ~ 45°C

Relative humidity of < 85%.

More severe conditions require special instructions when ordering.

Precautions and dangers

Note: please follow the safe use instructions and legal notes.

The EV Charging Box must always be installed according to the legal requirements in the country of installation.

Danger: voltage hazard

This product can cause serious injury if you come into contact with its internal parts during work. Furthermore, please disconnect the power supply after use.

Repair:

Do not try to repair the product. In case of problems please contact the customer service.

Warning: opening the device without permission may cause danger

Opening the device without permission may cause harm to the user or cause significant damage to itself or the surroundings.

Note: unauthorized modification of the device will result in the loss of manufacturer's warranty

No unauthorized modification of the device is allowed, any attempt to do so and the manufacturer's warranty will be revoked.

Safety Precautions

1. Do not put inflammable, explosives, combustible materials, chemicals, combustible steam and other dangerous articles near the charging pile.
2. Keep the charging connector head clean and dry. In case of dirt, wipe it with a clean dry cloth. It is strictly prohibited to touch the core of the charging connector core with your hand while it is charging.
3. It is strictly prohibited to use the EV Charging Box if there is visible damage, cracks, abrasions or exposed metal in the connector or charging cable. In case of such, please contact the After Sales Service.
4. Do not attempt to dismantle, repair or modify the EV Charging Box. If in need for repair or modification, please contact the After Sales Service. Improper operation may cause damage, water leakage, power leakage or other situations which can lead to personal injury or product failure.
5. In case of rain and thunder, be cautions when charging.
6. Children are not allowed to approach or use the EV Charging Box during the charging process in order to avoid injury.
7. Do not attempt to charge the vehicle when moving. The vehicle must be at a complete stand still during the entire charging process.

1.Product Introduction

1.1 Product introduction

This product is a single-phase or three-phase EV Charging Box, solely used for a charging of electric vehicles. The equipment adopts industrial design principles. The protection level of the EV Charging Box reaches IP55, with good dustproof and waterproof functions, and can be operated and maintained safely outdoors. This series Electric Vehicle Charging Box come in two version: the cable version and the socket version.



Cable



Socket



RFID

Type	AWB1P32AT1/ AWB1P32AT2	AWB3P32AT2	AWB1P32AT2NCB	AWB3P32AT2NCB
Type (RFID)			AWB1P32ARF	AWB3P32ARF
AC power	1P+N+PE	3P+N+PE	1P+N+PE	3P+N+PE
Power supply Voltage	AC230V~±10%	AC400V~±10%	AC230V~±10%	AC400V~±10%
Rated current	10-32A			
Frequency	50-60Hz			
Cable length	5m			
Sockets/plugs	type1/type2	type2	type2	type2
Weight	4.9kg	5.9kg	2.8kg	3.0kg
IP grade	IP55			
Environment temperature	-40℃ ~45℃			
Humidity	no condensation			
Cooling way	natural cooling			

2. Mechanical And Electrical Installation

2.1 Internal Structure Drawing

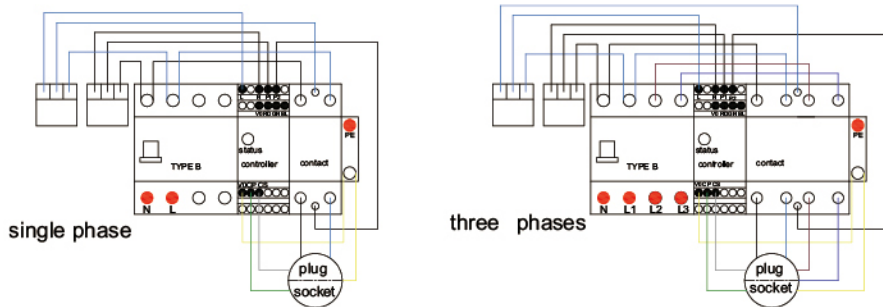
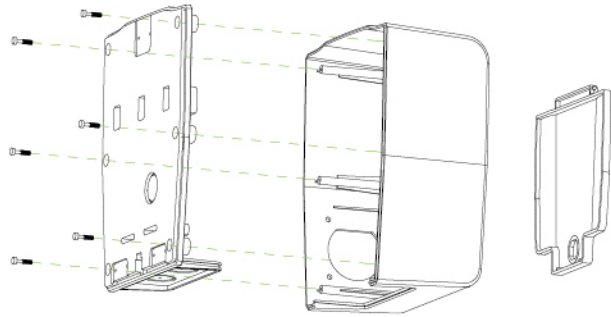

2.2 Installation

1). Overall dimension and installation size (unit: mm)

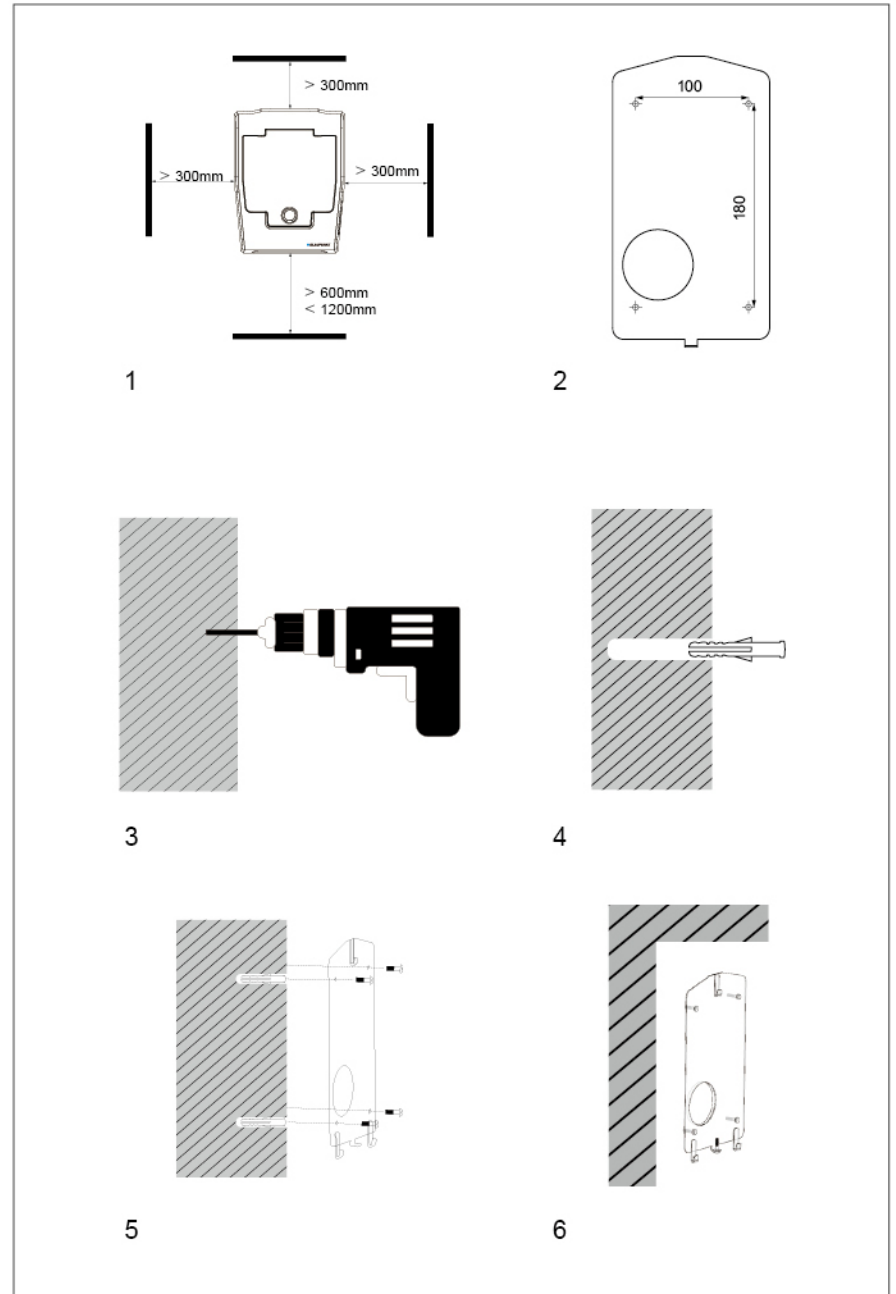
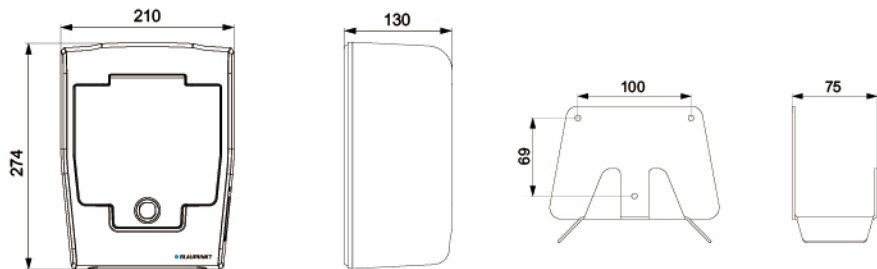

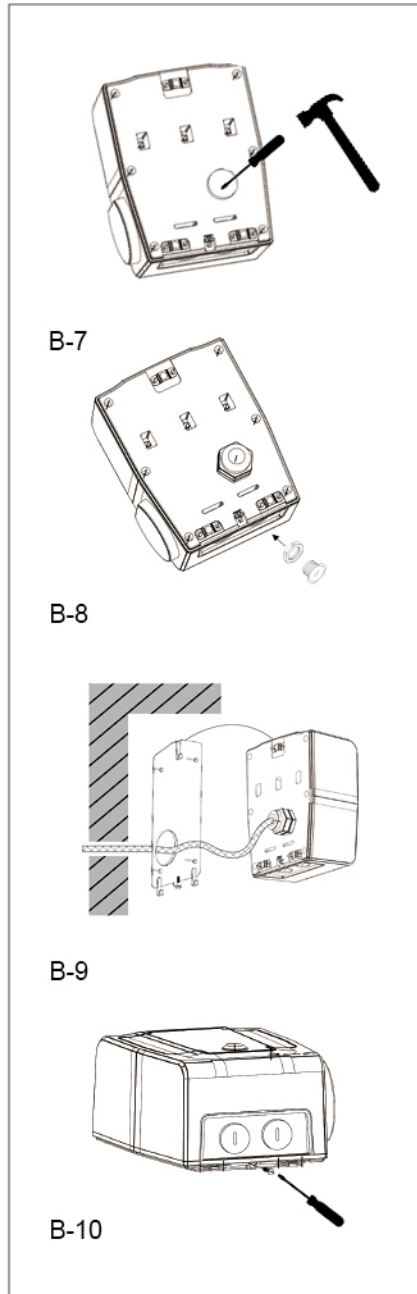
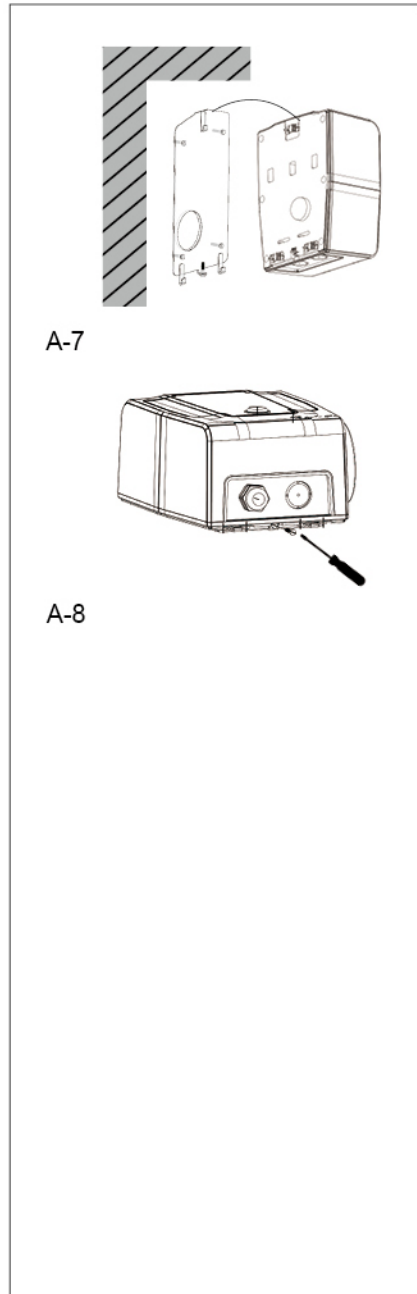

2). The power line is connected with a Type B Residual current circuit breaker, the single-phase EV Charging Box is connected with N and L, and the three-phase EV Charging Box is connected to N, L1, L2 and L3. Ground wire (PE wire) is connected to the yellow and green terminals.

3). Recommended cable section:

A	10	16	20	25	32
mm ²	2.5	2.5	4	4	6

4). Current option and setting by DIP switch

WARNING: Installation and AMP settings are only to be carried out by a trained and authorized electrical installer.

The current of the device is set to 32Amp as default factory setting

However, the rating can be adjusted to 10, 16, 20, 25, 32A via built-in DIP switch of protocol controller as user request.

DIP switch settings for the RFID version:



If you want to use the charging station without RFID authorization the "Lost Card" setting can be used.

DIP switch settings for the cable and socket version:

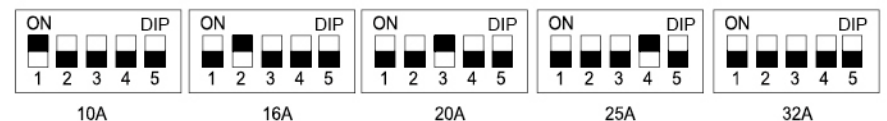
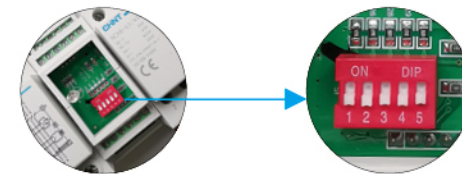

3. Charging Process

3.1 Check before operation

Before operation, please carefully check and ensure the following items:

The installation position of the EV Charging Box should be convenient for operation and maintenance. The EV Charging Box shall be properly installed using the mounting bracket included in the accessories.

No external objects or parts are left on top of the EV Charging Box.

3.2 Power on the equipment

A. Confirm that all the above pre-operation inspection items meet the requirements.

B. Switch on the power supply inlet circuit breaker.

C. After the EV Charging Box is connected to the power supply, allow for 7 seconds of startup self-test time, and the indicator light will be displayed switching between red, blue and green.

D. Standard version: After the self-test is completed, the indicators blue light flashes for cable version, the indicators blue steady light for free/socket version and the EV Charging Box is ready for use and you can connect to you Electric Vehicle.

E. After connecting your EV Charging box to you Electric Vehicle, please refer to the table below for the status of the charging process.

LED Display		Cable Version
LED Display		Activity
No Power	No Light	Product not on
		No Power
		The EV Charging Box has malfunctioned
Blue	Light Flashing	To be connected
Blue	Stable	Connection OK – 1 sec stable blue before the charging process begins. Upon completion of the charging process the light returns to stable blue.
Green	Stable	Charging
Red	Stable	Your Electric vehicles require heat dissipation, stop charging
Red	Light Flashing	Failure, not charging

4. Use of the card reader (RFID)

LED Display		Activity
No Power / No Light		Product not on
No Power / No Light		No power
No Power / No Light		The EV Charging Box has malfunctioned
Blue	Stable	To be connected
Blue	Light Flashing	Connection OK
Green	Stable	Charging
Green	Light Flashing	Charging completed
Red	Stable	Electric vehicles require heat dissipation, stop charging
Red	Light Flashing	Failure, not charging

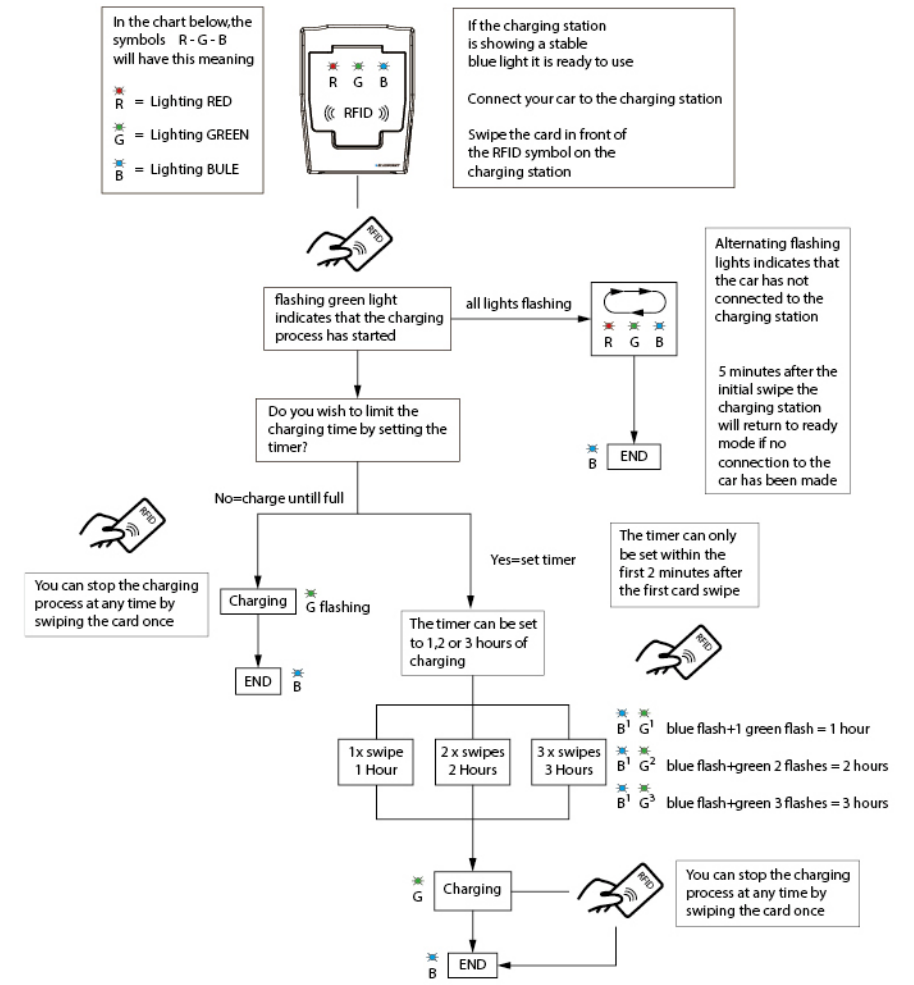

5. Warranty

RFID Version		
LED Display		Activity
No Power	No Light	Product not on
		No power
		The EV Charging Box has malfunctioned
Blue	Stable	To be connected
Blue	Light Flashing	Connection OK
Green	Light Flashing	Charging
Green	Stable	Charging completed
Red	Stable	Electric vehicles require heat dissipation, stop charging
Red	Light Flashing	Failure, not charging

5.1 The warranty period of this product is 24 months after the date of purchase. During the warranty period, if handled properly and according to manual, if the product becomes defect please contact our After Sales Service for assistance.

5.2 During the warranty period, a certain maintenance fee will be charged for damage caused by the following reasons:

- A. Damage caused by wrong use of the product and unauthorized repair and modification.
- B. Damage caused by abnormal fire, flood or other natural disasters and secondary disasters.
- C. Damage caused by dropping the unit or damage caused by transportation after the purchase.
- D. Damage caused by failure to operate according to the user manual provided by our company.

5.3 For After sales service, please call:

- Sweden 031 3045 665
- Denmark 77 34 33 30
- International +45 77 34 33 30

5.4 BLAUPUNKT reserves the right to interpret this agreement.