



akYtec ALP

Programming software for akYtec programmable devices

User manual

Contents

1	General	4
1.1	Abbreviations and terms	4
1.2	About software	4
1.3	System requirements	4
2	User interface	6
2.1	Menu	6
2.2	Toolbars	9
2.3	Workspace	10
2.4	Library Box	11
2.5	Property Box	12
2.6	Display Manager	12
2.7	Status bar	14
2.8	Variable Box	15
2.9	Component Manager	15
2.9.1	Online Database	16
2.9.2	Local library	17
3	Usage basics	18
3.1	Program execution	18
3.2	Program cycle time	18
3.3	Project creation	18
3.4	Connection to device	19
3.4.1	OFFLINE mode	20
3.5	Device information	20
3.6	Project information	21
3.7	Upload project to device	21
3.8	Firmware update / repair	22
3.8.1	Forced firmware update / repair	23
4	Device configuration	24
4.1	Display	24
4.2	Clock	24
4.3	Interfaces	25
4.3.1	Modbus working	25
4.3.2	Add / remove interface	27
4.3.3	RS485 Interface configuration	28
4.4	Extension modules	33
4.5	Inputs	33
4.6	Outputs	34

4.7	Calibration	35
4.7.1	Input calibration.....	35
4.7.2	Output calibration.....	35
4.8	Change target device	36
5	Variables.....	37
5.1	Properties	37
5.2	Data type	38
5.3	Standard variables	38
5.4	Service variables	39
5.5	Network variables.....	39
5.6	Copy / paste variable block	40
6	Library	42
6.1	Functions.....	42
6.1.1	Logical operators	42
6.1.2	Mathematical operators	44
6.1.3	Relational operators.....	47
6.1.4	Bitshift operators	49
6.1.5	Bit operators.....	50
6.2	Function blocks	52
6.2.1	Triggers	52
6.2.2	Timers	54
6.2.3	Generators	57
6.2.4	Counters.....	57
6.2.5	Analog.....	60
6.3	Project macros	62
6.3.1	Export, import, download macro	63
6.3.2	FB in macro.....	63
6.3.3	New macro using main menu	64
6.3.4	New macro using context menu	65
6.3.5	Update macro	66
6.3.6	Replace macro.....	66
6.3.7	Changing I/O points order.....	67
6.4	Display elements	67
6.4.1	Text box	68
6.4.2	I/O box (INT/REAL).....	68
6.4.3	I/O box (BOOL)	70
6.4.4	Dynamic box	70
6.4.5	ComboBox	71
7	Circuit program development	73
7.1	Using of library blocks	73

7.2	Using of text field.....	74
7.3	Using of variables.....	75
7.4	Using of constants.....	76
7.5	Using of delay lines	76
7.6	Network data exchange	77
7.7	Read / write in FB.....	78
7.8	Conversion blocks.....	79
7.9	Arrange elements.....	79
7.10	Execution sequence	80
7.11	Simulation	80
7.11.1	Operation	80
7.11.2	Watch Window.....	82
7.12	Online debugging.....	82
8	Display programming	84
8.1	Display Editor	85
8.2	Graphical structure	85
8.3	Form properties / Jumps	85
8.4	Copy / paste display form.....	87
9	Keyboard shortcuts.....	88
10	Program examples	89
10.1	Task 1: Light switch with automatic switch-off.....	89
10.2	Task 2: Mixer control	91

1 General

1.1 Abbreviations and terms

Abbreviations and terms used in this manual:

Table 1.1

Abbreviations and terms	Explanation
ALP	Programming software
FBD	Function Block Diagram is a graphical programming language
Function	Structural unit of a program with one return value. The function does not store information about its internal state, i.e. if the function is called with the same input values, it will return the same output value.
Function block	Structural unit of a program with internal memory and one or more output values. It is used in a program as an instance, i.e. a copy with its own memory.
Macro	Function block created by the user
Program cycle	Execution time of the circuit program, which depends on its complexity
Project	User application created for a programmable device with ALP software
Target device	Device for which the project is created
Workspace	Area in the software user interface to create a user program by placing program blocks and connecting lines between them

1.2 About software

ALP is the programming software for programmable devices of akYtec GmbH. The programming language is the graphical language FBD (Function block diagram). The software enables testing of the created program and its upload to the non-volatile memory of a programmable device.

Each project contains one or several circuit programs and a device configuration.

The first workspace contains the main circuit program. Macros (user function blocks) can be created as circuit programs on separate workspaces.

If the target device has a display, it can be programmed using display forms, each of them is opened in separate workspace.

Only one project at a time can be opened.

1.3 System requirements

ALP software runs on Windows XP/Vista/7/8/10. Pre-installed software .NET Framework 4.0 is required. If not installed, you will be asked to install it.

Minimum hardware requirements:

- 1.5 GHz processor
- 1 GB RAM
- 100 MB available hard disk space
- Free USB port

General

- Keyboard and mouse
- Screen resolution 1024x768

Recommended hardware requirements:

- 3.2 GHz processor
- 4 GB RAM
- 200 MB available hard disk space
- Free USB port
- Keyboard and mouse
- Screen resolution 1280x800

Internet connection is required for:

- Software update
- Device firmware update
- Slave device template download
- Macros download in Component Manager

User interface

2 User interface

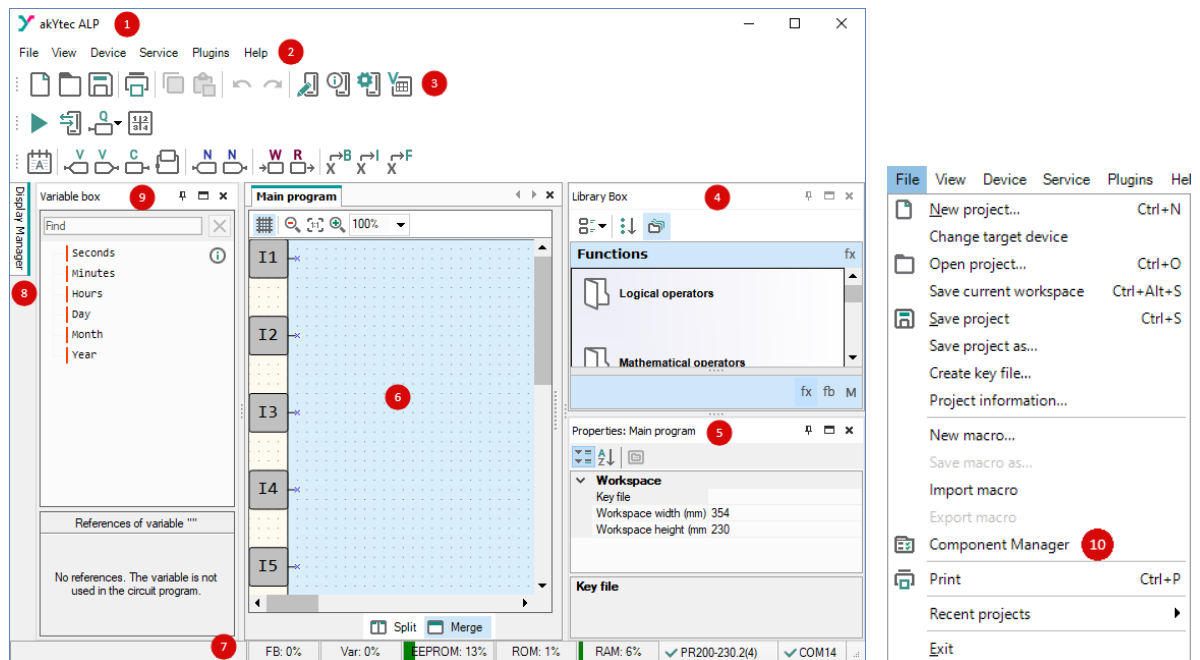

Fig. 2.1

1. **Title bar** – shows the name of the software and the path to the open project file
2. **Menu bar** – consists of the following groups: File, View, Device, Service, Plugins and Help
3. **Toolbars** – Standard, Service and Insert: quick access to the essential functions of ALP
4. **Library Box** – a panel that displays all the functions, function blocks, and macros that can be added to the project
5. **Property Box** – a panel where the properties of the selected project element can be viewed and modified
6. **Workspace** – a field in the user interface where a circuit program, display structure or a display form can be viewed and modified
7. **Status bar** – shows status and error messages, target device memory usage, status of the connected device and the programming interface
8. **Display Manager** – a tool to program the displayed information (available only for devices with display)
9. **Variable Box** – a panel in which all project variables with their parameters and references are displayed. Use drag-and-drop to place a variable block in a circuit program.
10. **Component Manager** – a special tool in a separate window to access the Online Database and to add the elements from Online Database to an offline library or to the project library. Internet connection is needed.

2.1 Menu

Table 2.1 Menu **File**

New project	Open a new project. The current project will be closed. (sect. 3.3)
Change target device	Change the target device in the project (sect. 4.8)

User interface

Open project	Open a previously saved project
Save current workspace	Save the currently opened workspace
Save project	Save the current project
Save project as...	Make a copy of the project in a different folder or with a different name
Create key file...	Create a file with a key to protect the project from unauthorized access (in development)
Project information...	View and modify the information about the project (sect. 3.6)
New macro...	Open the new macro in the separate workspace (sect. 6.3.1)
Save macro as...	Save the current macro under a new name in the project library
Import macro	Import a macro from a file into the project library (sect. 6.3.3)
Export macro	Save the current macro as a file (sect. 6.3.2)
Component Manager	Open the Component Manager interface (sect. 2.9)
Print	Open the dialog to set the print options and print the active workspace
Recent projects	List of recently opened projects
Exit	Close ALP

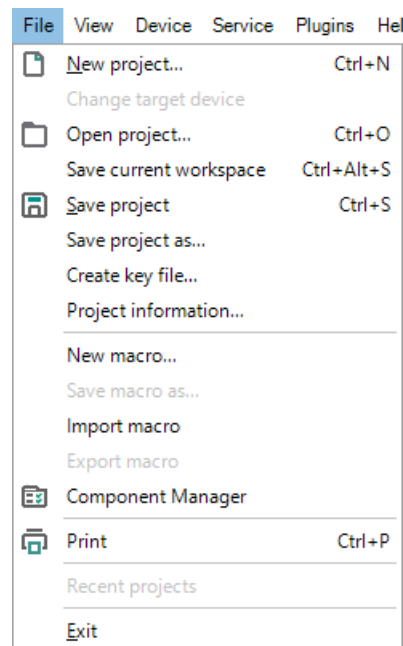

Fig. 2.2 Menu **File**

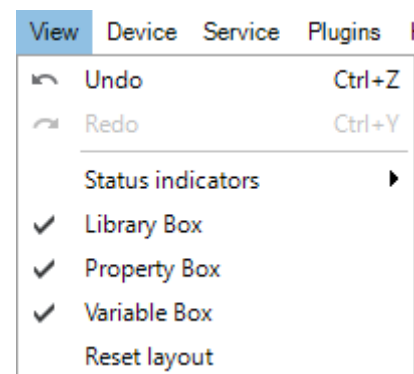

Fig. 2.3 Menu **View**

Table 2.2 Menu **View**

Undo	Undo the last action
Redo	Redo the last undone action
Status indicators	Add / remove the indicators to / from the status bar (sect. 2.7)
Library Box	Show / hide Library Box (sect. 2.4)
Property Box	Show / hide Property Box (sect. 2.5)
Variable Box	Show / hide Variable Box (sect. 2.8)
Display Manager *	Show / hide Display Manager (sect. 2.6)

* Available only for devices with display

User interface

Table 2.3 *Menu Device*

Transfer application to device	Upload the current project to the device memory (sect. 3.7)
Firmware update...	Update the firmware of the connected device (sect. 3.8)
Device information	Information about the software, the target device and the connected device (sect. 3.5)
Variable table...	The editable table of the project variables with their parameters (sect. 5)
Calibration...	Start calibration (sect. 4.7)
Configuration...	Device configuration (sect. 4)
Port settings...	Settings of the programming interface (sect. 3.4)

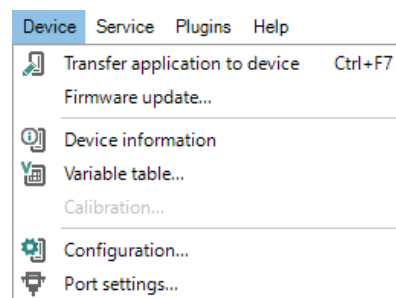

Fig. 2.4 *Menu Device*

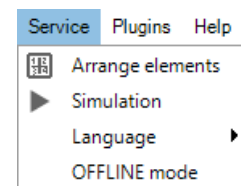

Fig. 2.5 *Menu Service*

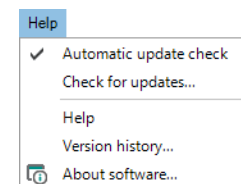

Fig. 2.6 *Menu Help*

Table 2.4 *Menu Service*

Arrange elements	Function blocks of the same type are automatically renumbered in the workspace from top to bottom and from right to left (sect. 7.9)
Simulation	Start / stop simulation (sect. 7.11)
Language	Select the interface language
OFFLINE mode	Activate OFFLINE mode (sect. 3.4.1)

Table 2.5 *Menu Help*

Automatic update check	If activated, the update check is performed on program startup
Check for updates	Check if software updates are available
Help	Online help
Version history	The list of changes for all software versions
About Software	Information about the current software version

User interface

2.2 Toolbars

Table 2.6

Standard		
	New project	Open a new project. The current project will be closed.
	Open project	Open a previously saved project
	Save project	Save the current project
	Print	Open the dialog to set the print options for the current workspace
	Copy	Copy the element selected in the workspace
	Paste	Paste the copied element
	Undo	Undo the last action
	Redo	Redo the last undone action
	Transfer application to device	Upload the current project to the device memory
	Device information	Information about the software, the target device and the connected device (sect. 3.5)
	Configuration...	Device configuration (sect. 4)
	Variable table...	Open the table of project variables for editing (sect. 5)
Service		
	Simulation	Start / stop simulation (sect. 7.11)
	Online debugging	Start / stop online debugging (sect. 7.12)
	Execution order	Change the execution order for the outputs or delay lines in a circuit program or in a macro (sect. 7.10)
	Arrange elements	Function blocks of the same type are automatically renumbered in the workspace from top to bottom and from right to left (sect. 7.9)
Insert		
	Comment field	Text field for program comments (sect. 7.2)

User interface

	Variable output block	Variable, which value can be written in the program (sect. 7.3)
	Variable input block	Variable, which value can be read in the program (sect. 7.3)
	Constant block	Constant value (sect. 7.4)
	Delay line	Feedback with one-cycle delay (sect. 7.5)
	Network variable output block	Variable, which value can be written via network (sect. 7.6)
	Network variable input block	Variable, which value can be read via network (sect. 7.6)
	Block WriteToFB	Connects the input value of the block to the selected parameter of the selected function block and used to change the parameter (sect. 7.7)
	Block ReadFromFB	Connects the output value of the block to the selected parameter of the selected function block and used to read the parameter (sect. 7.7)
	Conversion to BOOL	Conversion of any value to a BOOL value (sect. 7.8)
	Conversion to INT	Conversion of any value to an INT value (sect. 7.8)
	Conversion to REAL	Conversion of any value to a REAL value (sect. 7.8)

2.3 Workspace

When a project is opened, the workspace with the tab **Main program** is shown in the middle part of the window (Fig. 2.7).

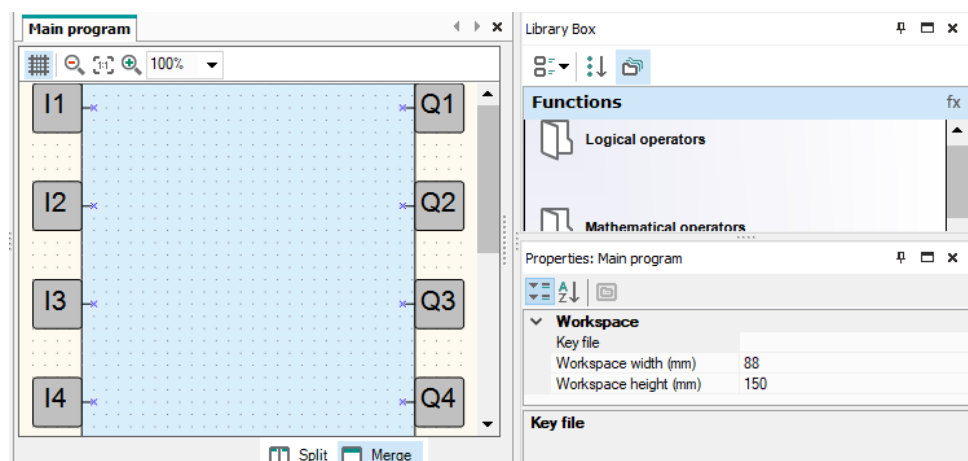

Fig. 2.7 Workspace

Circuit program is built and modified by placing program blocks and connecting lines between them in the workspace. The size of the workspace can be changed in Property Box. The inputs (left) and outputs (right) are signed as follows:

- Ix – digital inputs
- Alx – analog inputs
- Qx – relay outputs
- AOx – analog outputs

User interface

Fx – LED indicators

The numbers (x) correspond to the ordinal numbers of physical I/O points of the target device. I/O points can be moved up and down along the workspace by drag-and-drop.

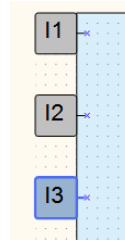

Fig. 2.8

Table 2.7 Workspace toolbar

	Show / hide grid	Show / hide vertical and horizontal rulers and a grid in the workspace. If the grid is visible, the blocks and connecting lines are snapped to the grid.
	Zoom -	Decrease the workspace by 10%
	Original size	Return to the original size (100%)
	Zoom +	Increase the workspace by 10%
	Select scale	Scale list from 20% to 400%

The icons **Split** and **Merge** are located on a toolbar below the workspace. Use the icon **Split** to show the same circuit program in two workspaces. It can be useful if the program is too large and you want to view two different parts of the program at the same time. Use the icon **Merge** to return to one workspace.

2.4 Library Box

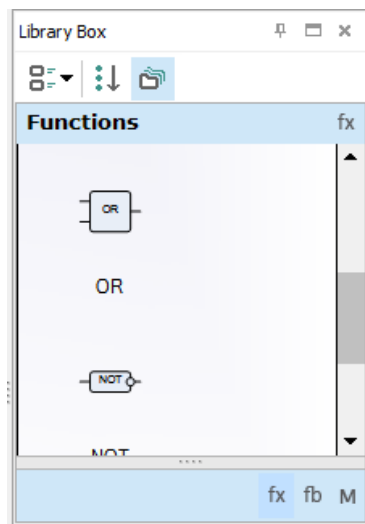

Fig. 2.9 Grouped tiles

The panel Library Box is a summary of program blocks available in the project. The panel consists of three libraries: **Functions**, **Function blocks** and **Project macros**.

Select an item on the lower toolbar of the panel to show the respective content.

The standard position of the panel is the upper right window corner (can be changed).

The panel view can be changed using the icons on the upper toolbar.

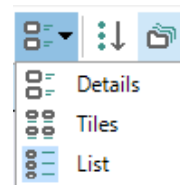

Click the icon **Show all** to show all the blocks of the selected library (Fig. 2.10):

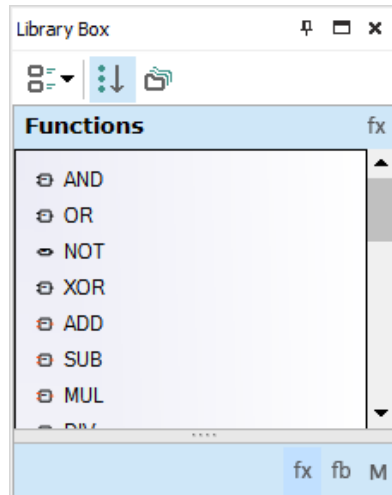

Fig. 2.10 Show all

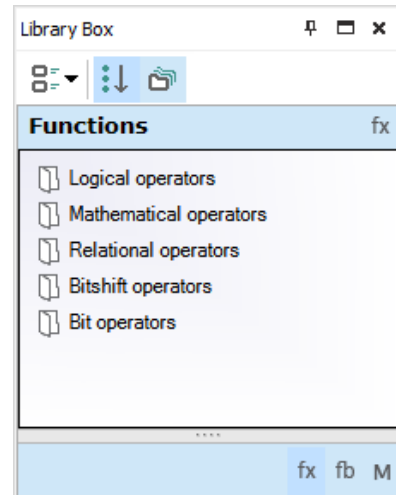

Fig. 2.11 Show grouped

Click the icon **Show grouped** to show the blocks of the selected library grouped (Fig. 2.11). Double-click the folder to open it.

For descriptions of the library groups and individual blocks see sect. 6.

2.5 Property Box

The panel Property Box is used to view and modify the parameters of the program elements. Select the element to view its properties.

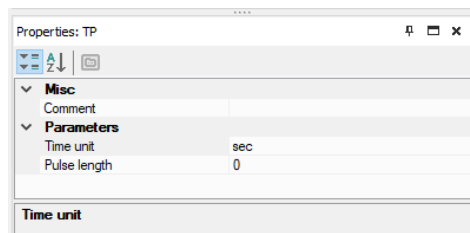

Fig. 2.12

The standard position of the panel is the lower right window corner (can be changed).

The parameters are shown grouped by categories by default.

To show them in alphabetical order, click the icon .

To show them grouped, click the icon .

Select the parameter input field to edit its value.

2.6 Display Manager

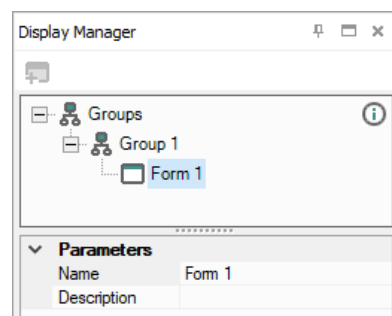

Fig. 2.13

If the target device has a display, the displayed information can be programmed using one or more display forms. For further details about display programming see sect. 8.

The programming is carried out using the programming tool **Display Manager**. The tab Display Manager is located in the upper left corner of the window. Click the tab to open the panel. The panel contains a toolbar, a display form hierarchical structure (tree) and a list of properties of the selected object.

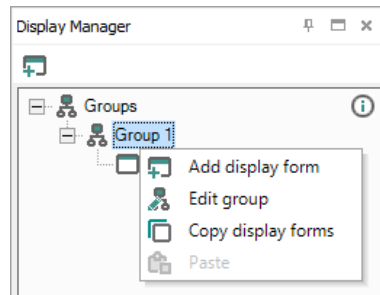

Fig. 2.14

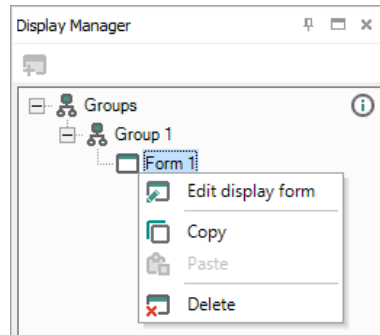



Fig. 2.15

The parameters of the selected display form are shown in the lower part of the panel.

To program the selected form, open it in a separate workspace **Display Editor** (Fig. 2.16), using the context menu or double-click the form in the group (Fig. 2.15).

The workspace shows the selected display form with the icons  on the right of it, which are used to change the number of the displayed rows. The rows displayed first are bold outlined.

For working with Display Editor see sect. 8.1.

If more than one display forms are created, you should specify "jumps" between them so that the operator can switch between forms to see the desired information. It can be done in a separate workspace **Structure Editor** (Fig. 2.17), presented the graphical structure of display forms with "jumps" and their conditions. To open it, use the command **Edit group** in the group context menu (Fig. 2.14).

For working with Structure Editor see sect. 8.2.

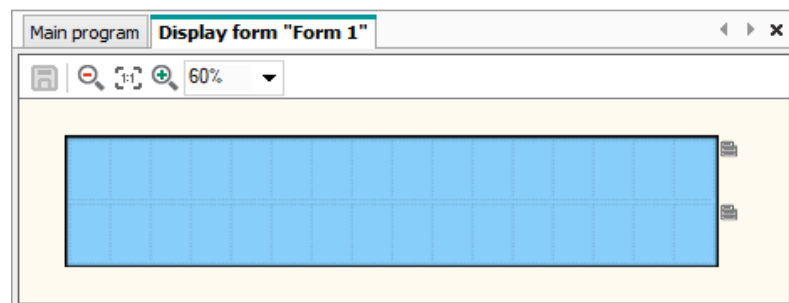

Fig. 2.16 Display Editor

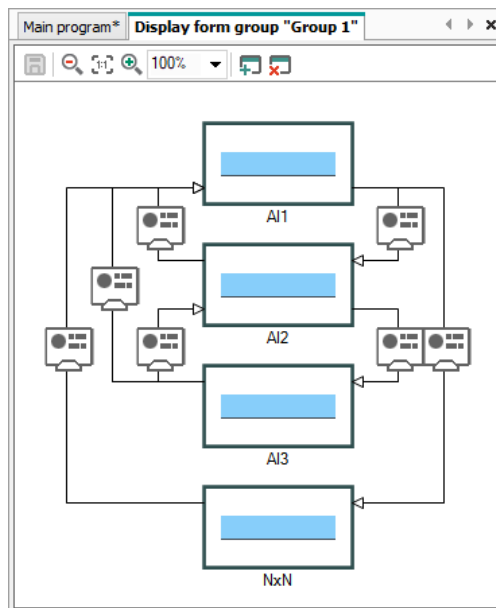

Fig. 2.17 Structure Editor

Table 2.8 Editor toolbars

Common	
	Save workspace
Zoom	
	Zoom out by 10%
	Original size
	Zoom in by 10%
<input type="text" value="100%"/>	Select scale
Display form	
	Add display form
	Delete display form

2.7 Status bar

Status and error messages are displayed in the left field of the status bar.

Besides that the status bar contains different status indicators that show information about the memory usage of the target device (resource indicators), status of the connected device and the programming interface. Which indicators are available in the status bar, depends on the type of the target device.

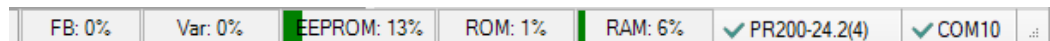

Fig. 2.18

Resource indicators show the used resource in percent of the total available amount. Move the mouse over the indicator to see the absolute amount of the resource.

If the device is connected, the status bar contains the following information:

- **FB** – the number of the available and used function blocks
- **Var** – the number of the available and used variables
 - Note: Some variables can be created by the software automatically, if such elements as delay lines or multiple connecting lines with common nodes are used in a project.*
- **Stack** – the number of the available and used stack levels
- **EEPROM** – the available and used retain memory
- **ROM** – the available and used ROM memory
- **RAM** – the available and used RAM memory
 - Note: ALP software automatically calculates the available resources of the device and shows a warning if the critical value is reached.*
- **Device** – the type of the connected device
 - Note: Click the indicator to switch to **OFFLINE** mode. In this mode the connection to device is interrupted. The next click deactivate **OFFLINE** mode (sect.3.4.1).*
- **Port** – the selected COM port number (programming interface).
 - Note: Click on the indicator to open the window **Port settings**.*

User interface

2.8 Variable Box

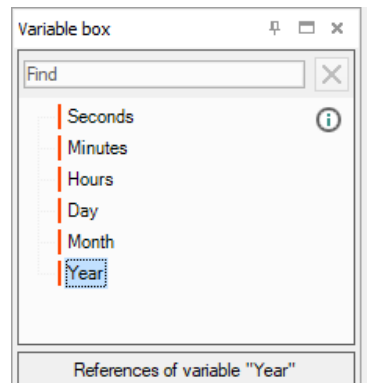

Fig. 2.19

The panel **Variable Box** shows the project variables from the variable table.

The standard position of the panel in the upper left window corner and can be changed.

You can view the information about the variable in a tooltip text.

The variable references are shown as links in the lower panel part. If you click on the link, the block to which the variable is referred is highlighted in the workspace.

Drag-and-drop a variable to place it in the circuit program as an input block.

To use a variable as an output block, hold the Shift key pressed as you drag-and-drop the variable.

If a variable is drag-and-dropped onto a connection pin of a block, the created variable block is connected to this connection pin.

If a variable is used at more than one place in the project, all the references can be viewed with the item **Show references** in the variable block context menu. Click on the link to view the reference (Fig. 2.20).

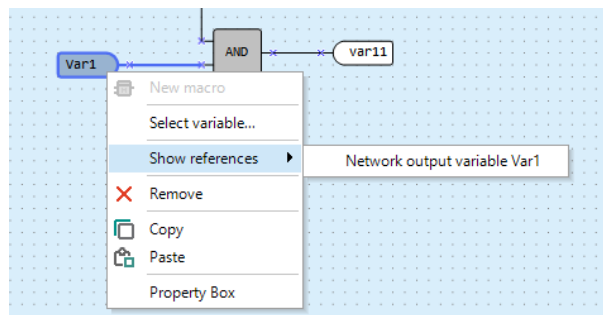

Fig. 2.20

2.9 Component Manager

New macros and device templates can be downloaded from akYtec Online Database. Component Manager is the tool for all interactions with this database. Select the menu item **File > Component Manager** to open it in a separate window.

User interface

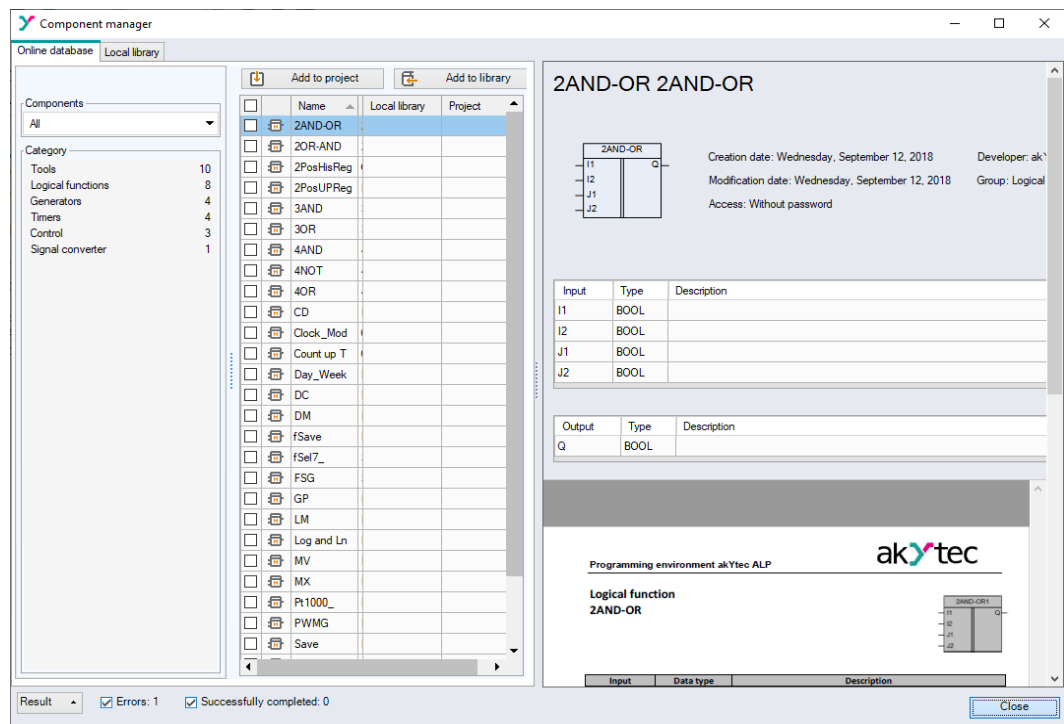

Fig. 2.21

The internet access is necessary for Component Manager to interact with Online Database.

The interface has two tabs: **Online Database** (sect. 2.9.1) and **Local library** (sect. 2.9.2). Blocks are shown in categories and can be filtered by name.

2.9.1 Online Database

- **Add to project** button – the selected blocks (macros or device templates) from Online Database are added to the project library. The blocks are then stored in the project file and can be viewed in Library Box (sect. 2.4) in the **Project Macros** area.
- **Add to library** button – the selected blocks from Online Database are downloaded to the local library and can then be used offline.

A check mark in the column **Project** or **Library** indicates that the block has been successfully downloaded / added.

Library files are stored at the local address:

**C: \Users \[username] \Documents \akYtec ALP \Library **

The brief description of the selected block is displayed in the upper right field, and the full description in the lower right field. The full description is a PDF document. Scroll the document to the end to see the PDF toolbar. Using it, you can download the document or print it.

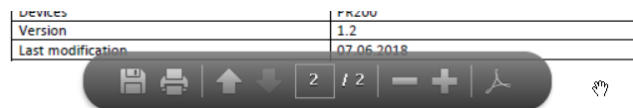

Fig. 2.22

Click the button **Operation result** at the bottom of the window to view the program messages about the performed operations.

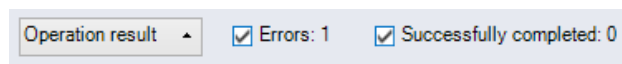





Fig. 2.23

User interface

2.9.2 Local library

- **Add to project** button  – the selected blocks (macros or device templates) from Online Database are added to the project library. The blocks are saved in the project file and can be viewed in the Library Box (sect. 2.4) in **the Project Macros** (sect. 6.3) area.
- **Import** button  – the selected blocks are added from a file in the project library.
- **Export** button  – the selected blocks from the project library are saved as files under the specified path.
- **Remove** button  – the selected blocks are removed from the local library.

3 Usage basics

To program the device, proceed as follows:

- Start ALP
- Create a new project for the selected target device or open an existing project (sect. 3.3)
- Save the project on the PC
- Test and debug the program in the simulation mode (sect. 7.11)
- Upload the project to the connected device (sect. 3.7)

3.1 Program execution

The selected target device determines the number of available inputs and outputs and the availability of a real-time clock. The general structure of the programmable relay is shown in Fig. 3.1.

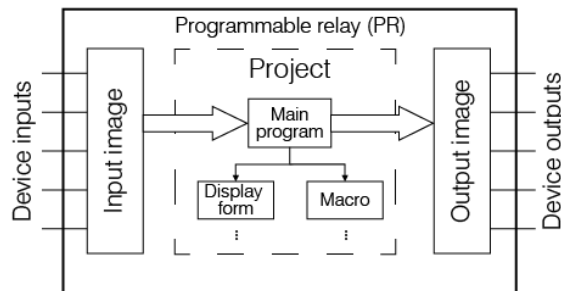

Fig. 3.1 PR operation flowchart

The programmable relay is a kind of PLC with a cyclically executed program:

Step 1 – The status of physical inputs is saved to the input memory cells (Input Image Table).

Step 2 – The input memory cells are read out and the program is executed from its first instruction to the last one.

Step 3 – The results are saved to the output memory cells (Output Image Table) and applied to the outputs.

When the last step is completed, the program runs again from the first step.

3.2 Program cycle time

The cycle time is calculated by the device and depends on program complexity. The following blocks are especially resource-intensive:

- FBs (sect. 6.2)
- macros (sect. 6.3)
- network variables (sect. 5.5)
- display elements (sect. 6.4).

It is a read-only parameter and can be viewed on the device display (if exists) using the system menu (see user guide). The minimum cycle time is 1 ms.

Note: The parameters **Cycle time** in device and in ALP simulation mode (sect. 7.11) are different in spite of the same name.

3.3 Project creation

To create a new project select **File > New project** in the main menu or use the equivalent icon in the taskbar. Select the target device in the dialog window **Device selection** and confirm it with **OK** (Fig. 3.2).

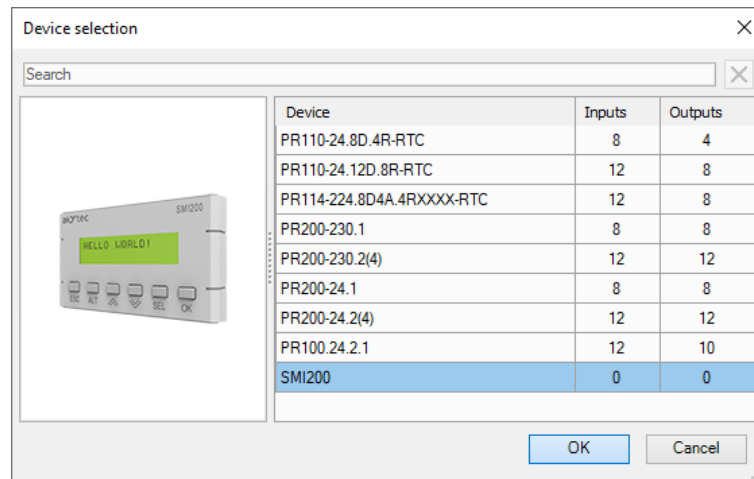

Fig. 3.2

The new project appearance:

- workspace – empty circuit program
- status bar – information about available resources
- Library Box – available program blocks
- Property Box – workspace properties.

Circuit program

Now you can create the main circuit program in the workspace using the common program blocks from the toolbar **Insert** and the specific program blocks from Library Box. Draw connecting lines between inputs, outputs and program elements to establish logical connections in the program. For details about individual program block and connecting lines see sect. 7.

Display Manager

If the selected device has a display, the **Display Manager** tab appears to the left from the workspace. With this tool you can program the displayed information.

Simulation

Program can be simulated offline. Start the simulation mode using the menu item **Service > Simulation** or the toolbar icon , change the state of the inputs and notice the state of the outputs to check the correctness of the program (sect. 7.11).

Online debugging

If the device is connected and the program in the device and in ALP is the same, you can use online debugging to check the correctness of the program in the device (sect. 7.12).

3.4 Connection to device



The device must be powered off before connecting to PC.

Devices can be connected to PC directly (PR200, SMI200) or over PR-KP20 adapter (PR110, PR114). The required connection cable is included in the package of PR200 or the adapter.

Connect the device to a USB port of the PC, switch the power on and select the serial port in the menu **Device > Port settings**. The number of the emulated COM port can be found in the Windows Device Manager under “Connections (COM and LPT)”.

Usage basics

If the operating system does not find the correct driver, install the driver for PR200 or for the adapter PR-KP20. It can be downloaded from akytec.de.

Select the port number in the dialog window **Port settings** and confirm with **OK**. All other settings are fixed and displayed only for your information.

If the connection is established, the information about the connected device and the serial port is shown in the status indicators.

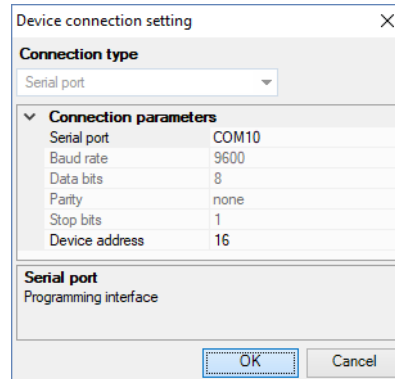

Fig. 3.3

3.4.1 OFFLINE mode

In this mode, the connection between ALP and the device is interrupted.

The mode is helpful when you work with two ALP instances running on PC and trying to communicate with the same device. Both applications will alternately occupy the port and the connection to the device will be constantly interrupted.

The application that should not communicate with the device should be switched to OFFLINE mode.

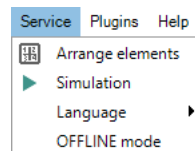



Fig. 3.4

OFFLINE mode can be activated / deactivated using the menu item **Service > OFFLINE mode** or by clicking the status indicator **Device** (sect. 2.7). With the next click is OFFLINE mode deactivated.

3.5 Device information

To view information about the software, the target device and the connected device use the menu item **Device > Information...** or the icon  in the toolbar.

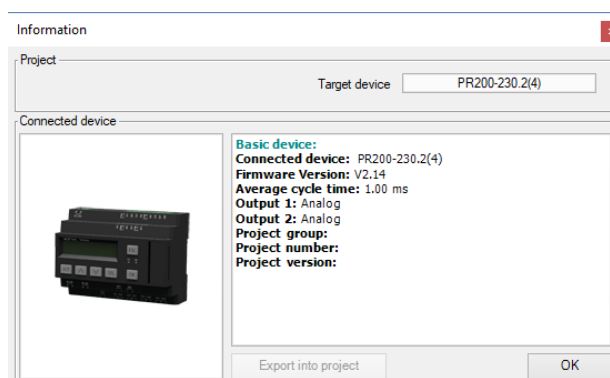

Fig. 3.5

The window **Device Information** contains the following information:

Target device – the device for which the project was created

Connected device – the information about the device connected to the PC

Export into project – the button is active only if the device PR114-224.8D4A.4RXXXX is connected. It can be used to export the real output types of the connected device into the project. Alternatively the type of each output can be manually changed in **Property Box** in accordance with the hardware.

3.6 Project information

Use the menu item **File > Project** information to view and modify the information about the project. The tab **General** contains the information about the version of the software.

Software version at project creation – the version of the software in which the project has been created

Software version at project modification – the version of the software in which the project has been modified

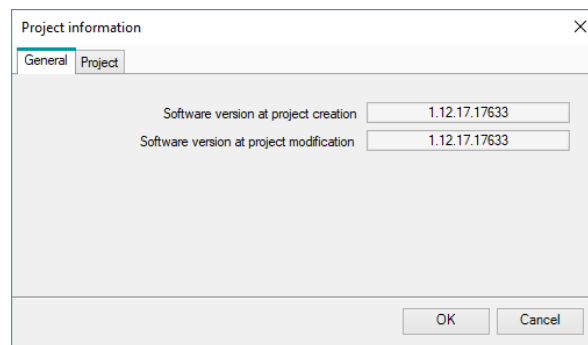

Fig. 3.6

The tab **Project** contains information about project version and is only for PR200 available.

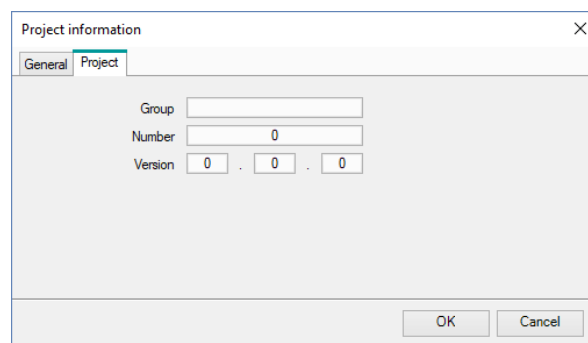

Fig. 3.7

Group – project group name

Name – project number within a Group

Version – project version

After you complete the desired entries, confirm them with OK, or click Cancel to discard them.

3.7 Upload project to device

Attention! The program already stored in the connected device will be replaced by the new one.

Usage basics

Proceed as follows:

- connect the device to PC
- power on the device
- adjust the port settings if necessary
- upload the project to the device

The project can be uploaded to the device using the menu item **Device > Transfer application to device** or clicking the icon  in the toolbar. When the upload is completed, the device can be powered off and disconnected from the PC.

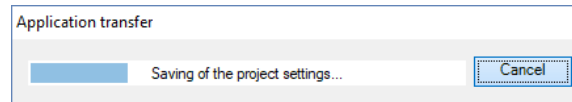

Fig. 3.8

If the target device does not match the connected device, a warning message will be displayed.

Note: After the program transfer is completed, the device goes to the operating mode and the program starts automatically.

3.8 Firmware update / repair

If a new ALP version includes a new version of the firmware for the connected device or extension module, you will be prompted to update the firmware before uploading a user program to the device. No internet connection is needed. Click **Yes** to start the update.

Note: Ensure the power supply of the device and extension modules (if any) and the safe connection between the PC, the device and the extension modules (if any) during the update process.

You can also update the firmware manually using the menu item **Device > Firmware update**. This way the firmware can be repaired when the firmware damage is detected (see respective user guide, table “Error indication”).

Note: The user program will not be affected by firmware update.

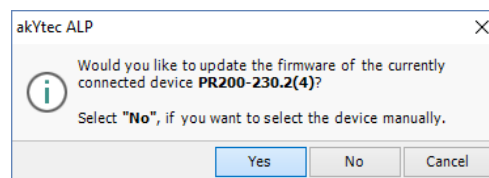

Fig. 3.9

If you select **Yes**, the firmware of the currently connected and recognized device will be updated (repaired).

If you select **No**, lists of devices and extension modules will be offered to select from (Fig. 3.10). The opened window has two tabs: **Device** and **Extension Module**. This way a forced firmware update can be made (sect. 3.8.1).

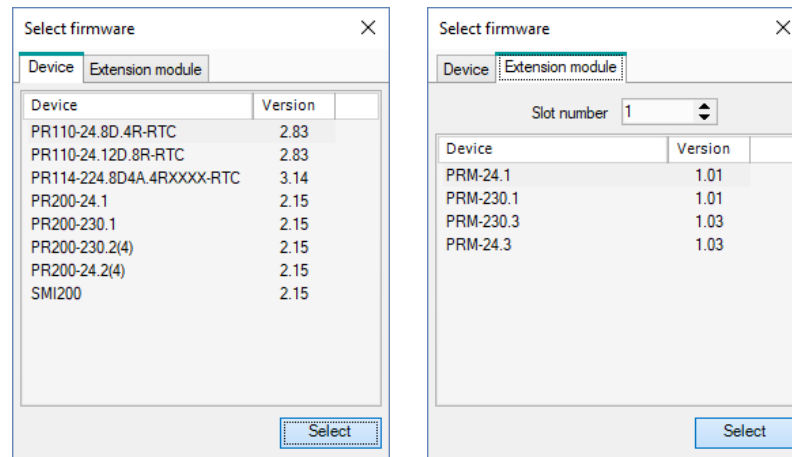

Fig. 3.10

Click **Select** to confirm the selection and start the update (repair) process. The message about the update result is shown upon the update completion.

3.8.1 Forced firmware update / repair

If the firmware is damaged (see respective user guide, table “Error indication”) and device automatic recognition is not possible, a forced firmware update should be used. Proceed as follows:

1. set the device in the forced download mode (see the device user guide)
2. select the menu item **Device > Firmware update**, lists of devices and extension modules will be offered to select from
3. select the device (extension module)
4. click **Select** to confirm the selection and start the update (repair) process.

The message about the update result is shown upon the update completion.

If the basic device and the extension module have incompatible firmware versions and the user program is uploaded to the basic device without the extension module connected, this may lead to an expansion module error displayed. To fix the error, use forced firmware update for the expansion module as described, skipping step 1.

4 Device configuration

The configuration of the device is a part of a project and can be set using the menu item **Device > Configuration**. The dialog window **Device configuration** consists of two parts. The configurable parameters of the device are presented in the parameter tree in the left part of the window. The content of a group is presented in the right part.

The content of the parameter tree depends on the target device and may include the following groups:

- Display
- Clock
- Interfaces
- Extension modules
- Inputs
- Outputs

All the settings are saved in the project, except the clock settings. The configuration is also possible without connecting the device.

4.1 Display

If the target device has a display, the following parameters can be set:

Backlight – the duration of the backlight since the last user activity

Brightness – 0...100%

Contrast – 0...100%

The button **Read** can be used to read out the current display settings from the connected device.

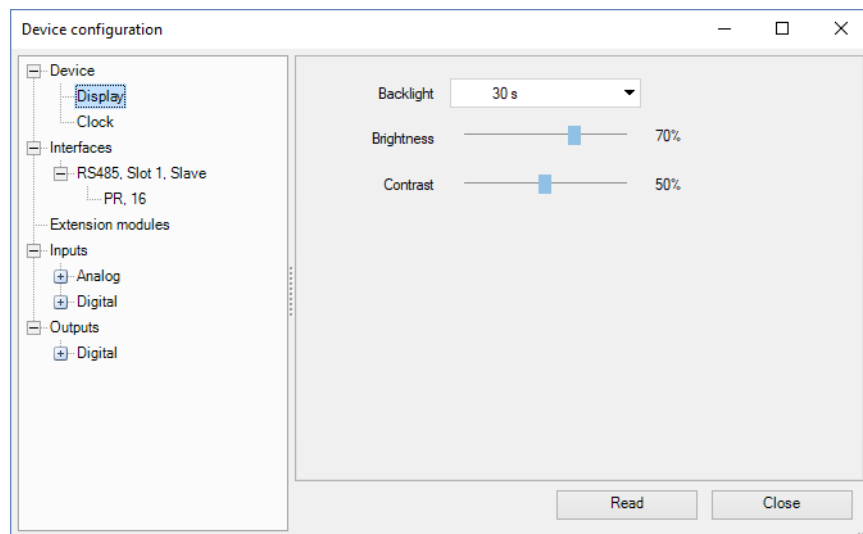

Fig. 4.1

4.2 Clock

If the target device has a built-in real-time clock, the date and time can be set in the **Clock** group.

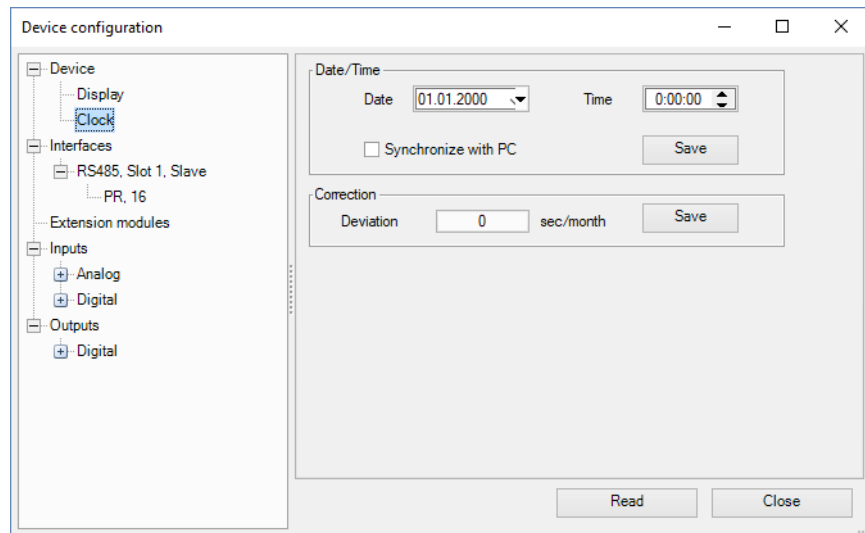

Fig. 4.2

To synchronize the device clock with the PC clock, check the checkbox **Synchronize with PC**. In this case the fields **Date** and **Time** become inactive. To set the device clock to the new values click the button **Save** in the section **Date/Time**.

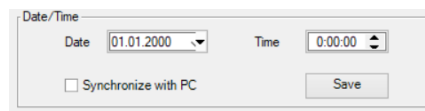

Fig. 4.3

Specify the clock error in seconds per month in the field **Deviation** to set the clock correction. Enter a negative value if the device clock is too fast.



Fig. 4.4

To save the clock correction in the device, click the button **Save** in the section **Correction**.

The button **Read** can be used to read the current time settings from the connected device.

4.3 Interfaces

If the target device has a serial network interface RS485, its parameters can be set in the group **Interfaces**.

By default, there is one interface configured as a slave and assigned to the hardware slot 1 with the following settings: master device with the name PR and the network address 16.

If the number of interfaces on the target device can be changed, interfaces can be added or deleted in the configuration, but their number cannot exceed the number of the existing slots (sect. 4.3.2).

If an interface is configured as a master, slaves can be added to the configuration or removed, but their number may not exceed 16.

4.3.1 Modbus working

ALP can be used to program devices that support Modbus-RTU or Modbus-ASCII (master / slave) protocols.

Device configuration

Note: The devices PR110 and PR114 can operate only in the slave mode and only with the PR-MI485 interface adapter.

In order to organize data exchange in the network over the RS485 interface, a master device is required. There can be only one master in the network.

Cycle time

The program execution time (cycle time) is automatically adjusted (auto-tuning) depending on the program complexity. The auto-tuning affects data exchange over Modbus, since the program execution has a higher priority than request processing. If the program is large, it can take up all the CPU time and Modbus data exchange will not be performed correctly.

To avoid this problem, the lower limit for the volume of the Modbus data exchange is reserved: 50 requests per second. Thus, at least 50 requests per second can be executed even if the user program is large, and even more if the program is small and the processor capacity is sufficient. If there is not enough time to poll all devices, the number of requests should be optimized in the user program.

The **Query cycle** setting depends on the number of polled variables and the polling frequency in the program. It is recommended to set **Query cycle** to 1 s. In this case, the device will be able to request up to 50 variables.

Query time

The query time is the actual time it takes the device to run all requests in a queue. If the queue is short, the device will perform all the request-response cycles and wait for the specified **Query cycle** to expire (Fig. 4.5). If the queue is long and the query takes longer than the specified **Query cycle**, the device will poll all slaves in the shortest possible time.

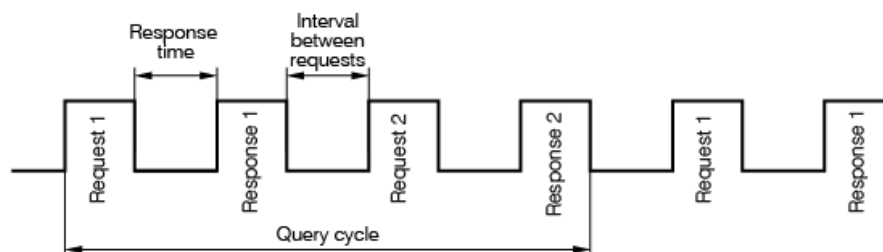

Fig. 4.5 Query time diagram

To minimize the request time, the following is recommended:

- If one or several slaves are not connected or temporarily unavailable, consider to block the polling in a program or to minimize the **Timeout** parameter for these devices.
- Consider the number of slaves and the total number of requests when setting the **Query cycle** parameter. If the processing time of all requests (query time) takes longer than **Query cycle**, the parameter will be ignored.

Polling of multiple devices in the network

Slaves are polled according to the generated queue from the smallest to the largest address. In the following example, the slave with the address 8 is polled first, with the address 32 last.

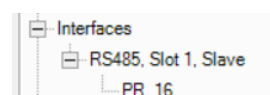

Fig. 4.6

Device configuration

Query cycle can be set for each slave individually.

4.3.2 Add / remove interface

If the device has a slot, for which no interface is configured, an appropriate interface can be added using the item **Add Interface** in the context menu.

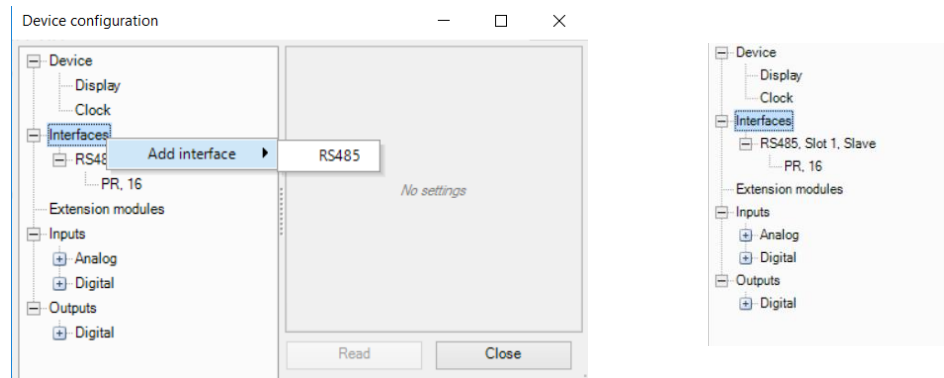

Fig. 4.7

An interface of the selected type with default settings is added.

Depending on device, the interface can be replaced by another type of interface or removed using the context menu.

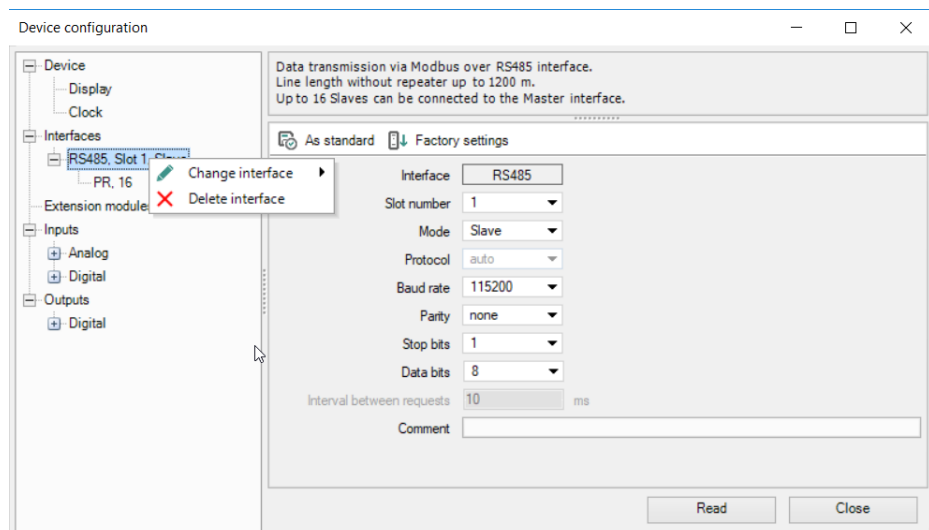

Fig. 4.8

Device configuration

4.3.3 RS485 Interface configuration

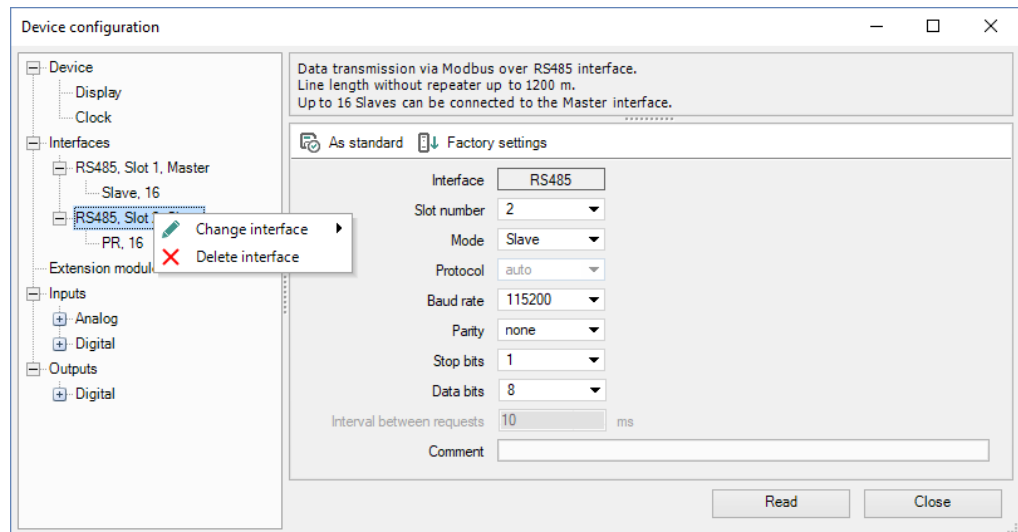



Fig. 4.9 Interface configuration

The type of the interface (RS485), the number of the assigned slot and the mode (master / slave) are displayed in the tree.

To establish the connection over the interface, it has to be configured. The parameters of the interface are displayed in the right part of the window. The default value depends on the target device. The parameters **Protocol** and **Interval between requests** are only in the master mode available. In the slave mode they are inactive and grayed out.

The icon  **As standard** is used to save the settings as default values for future projects.

The icon  **Factory settings** is used to apply the unchangeable factory settings.

The button **Read** is used to read out the current settings from the connected device.

Use the button **Close** to save the settings in the project and close the dialog.

4.3.3.1 Master mode

Each interface can control up to 16 slaves. Each slave supports up to 256 variables. The addresses and names of the variables need only be unique if they belong to the same slave.

In the master mode, all slaves connected to the interface are sequentially requested. Select the mode **Master** in the parameter list, set other connection parameters and add the required number of slaves using the item **Add slave** in the interface context menu.

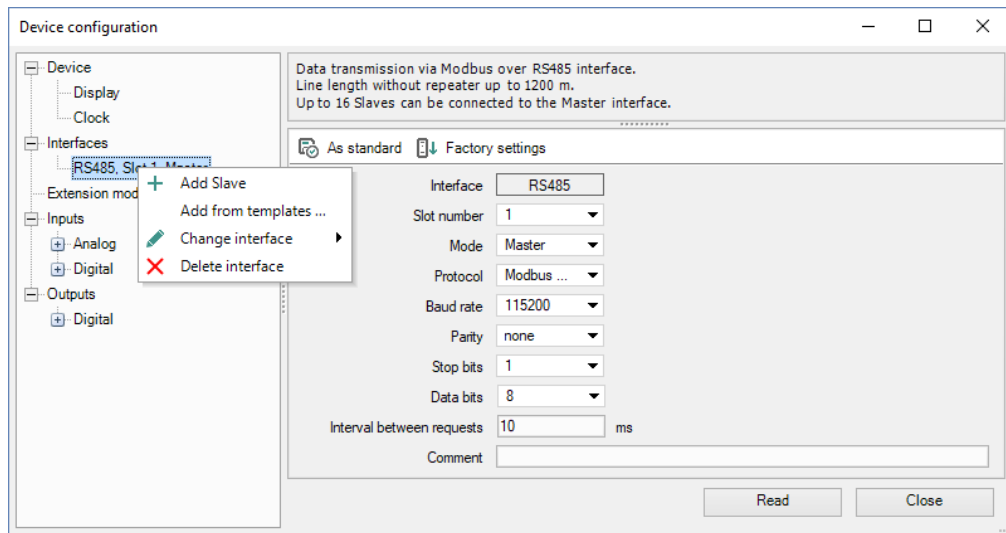

Fig. 4.10 Master configuration in master mode

The added slave device is displayed with its name and address in the tree below the interface. Select a slave to configure it in the right part of the window.

The parameters of the slave can be specified in the upper part of the window (Fig. 4.11).

To delete the slave, use the context menu or the icon **Remove Slave**.

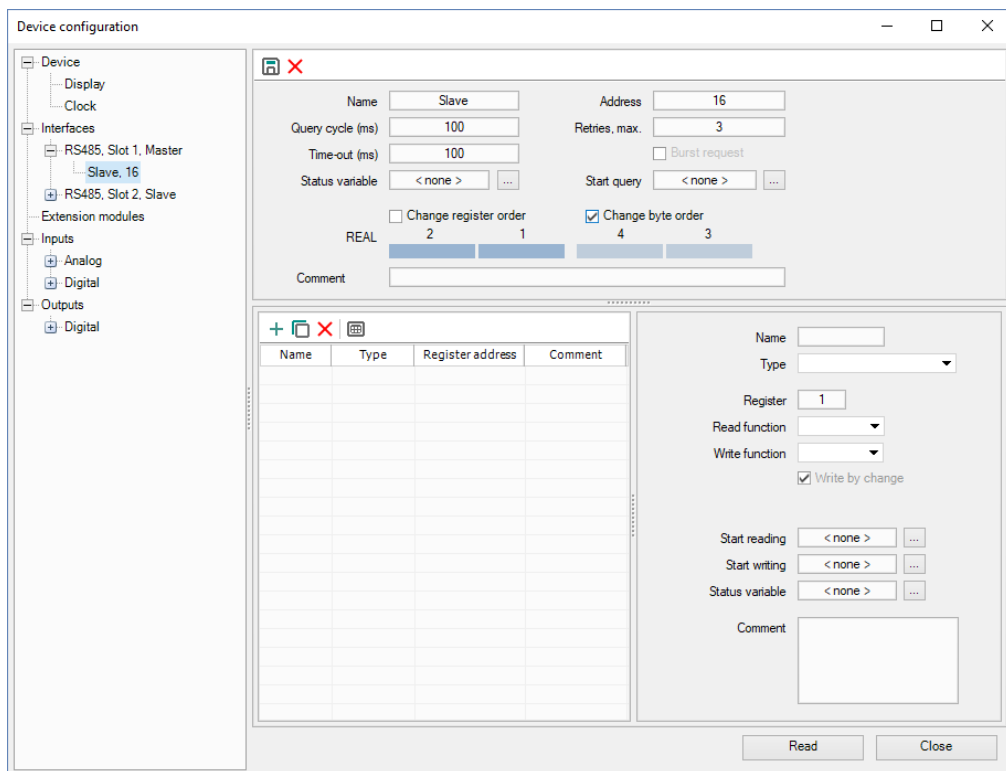



Fig. 4.11 Slave configuration in master mode

- **Name** – the name of the slave displayed in the tree
- **Address** – the network address of the slave
- **Query cycle (ms)** – the time interval between queries. A query comprises the number of requests according to the number of variables listed for the slave. The valid range is 0...65535 ms.
- **Timeout (ms)** – the time that request can take before the attempt is considered as failed. The valid range is 0...65535 ms.

Device configuration

- **Retries, max.** – the number of the failed request attempts before query is stopped and the status of the device changes. The valid range is 0...255.
- **Burst request** – group request of consecutive registers to increase the data throughput
- **Status variable** – select a BOOL variable using the icon  to record the device status:
 - 1 – the device functions properly
 - 0 – the device is not connected.
- **Start query** – select a BOOL variable using the icon  to control the query:
 - 0 – query disabled
 - 1 – query enabled.
- **Change register order** – determines the register order in two-register variables
- **Change byte order** – determines the byte order in the register
- **Comment** – the text comment to describe the device

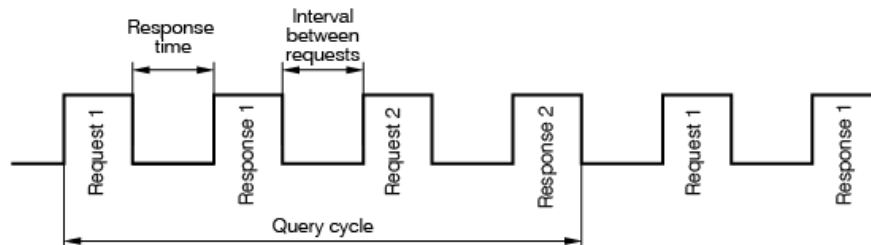
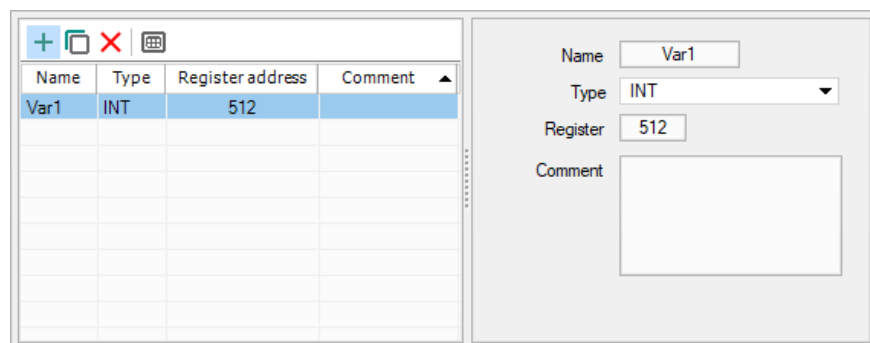

Fig. 4.12 Query time diagram

The list of the variables to be requested from this slave is in the lower part of the window. Each variable created in this list can be found in the variable table under the tab **Network, Slot X** with a separate list of variables (sect. 5.5) for each slave device.

Add a variable by clicking the icon  **New variable**, and set its properties.



Name	Type	Register address	Comment
Var1	INT	512	

Fig. 4.13 Variable configuration in master mode

- **Name** – the name of the variable
- **Type** – the data type of the variable: BOOL, INT or REAL
- **Register** – the register address
- **Bit** – the number of the bit of the register (0...15) (only for BOOL variables)
- **Read function / Write function** – selection of the read / write function or disable reading / writing.
- **Number of registers** – the number of registers occupied by the variable (only for INT variables)

Device configuration

- **Start reading** – assign the BOOL variable for forced reading of the requested variable
- **Start writing** – assign the BOOL variable for forced writing of the requested variable
- **Status variable** – assign the INT variable to record the error code
- **Comment** – the text comment to describe the requested variable

To create several variables with the same settings, select a variable and click the icon  **Duplicate**.

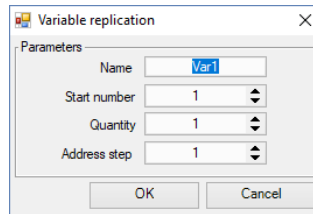



Fig. 4.14 Variable duplication

- **Name** – the name of the duplicated variable
- **Start number** – the initial number to add to the name of the duplicated variable
- **Quantity** – the quantity of the duplicated variables
- **Address step** – the address increment

Click **OK** to add the duplicated variables to the list of variables. The variables will be stored in adjacent register cells with consecutive addresses.

To remove the variable from the list, use the icon  **Delete**.

4.3.3.2 Templates

A slave device in the configuration mask can be saved as a template, with its parameters and variables, to be used in further projects. Use the context menu item or the icon  **Save Slave as a template** (Fig. 4.15). The template is saved as a file with the extension **.dvtp**.

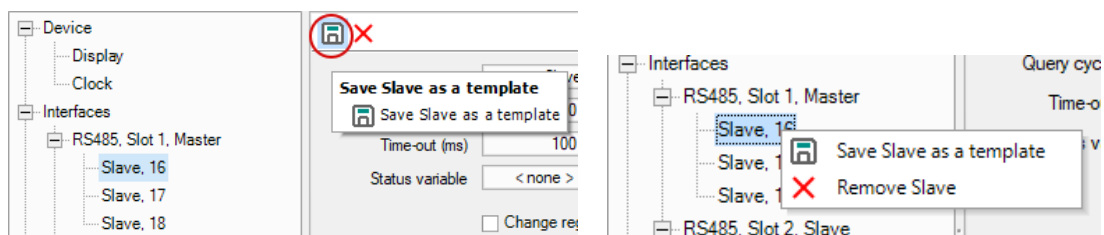

Fig. 4.15 Slave context menu

A slave can be added to a master as a template using the context menu item **Add from templates...** (Fig. 4.16).

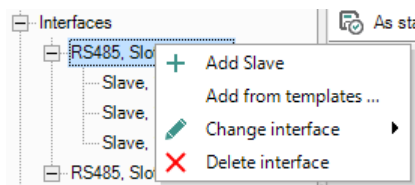

Fig. 4.16 Master context menu

4.3.3.3 Slave mode

An RS485 interface added to the tree item **Interfaces** has the default mode Slave and the default master with the name PR and the address 16 added below. Select the interface to set the connection parameters.

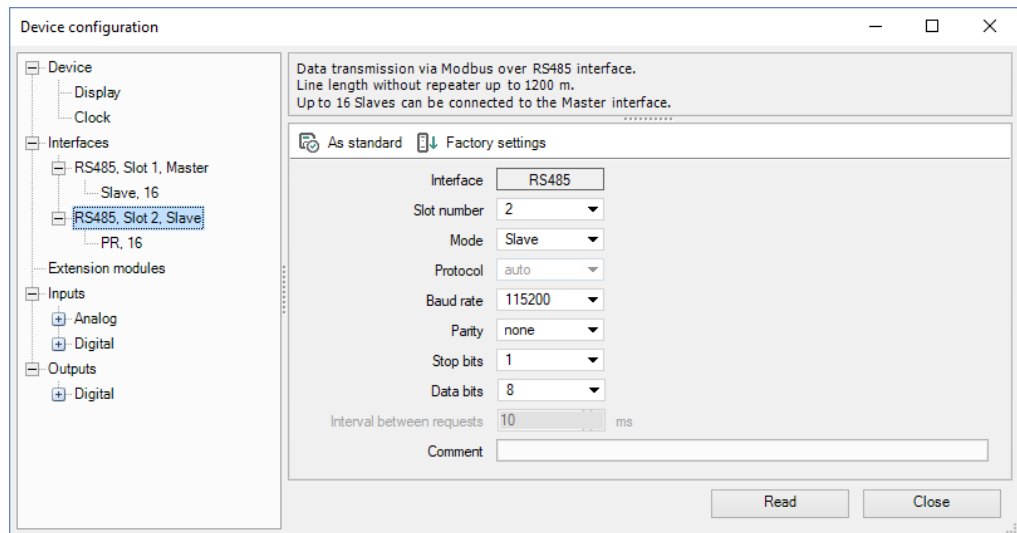

Fig. 4.17 Slave configuration in slave mode

Select the master in the tree to set the parameters for data exchange.

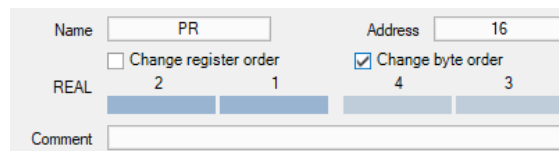

Fig. 4.18 Master configuration in slave mode

The common parameters for data exchange can be set in the upper window part.

- **Name** – the name of the master displayed in the tree
- **Address** – the network address of the master
- **Change register order** – the register order in two-register variables
- **Change byte order** – the byte order in the register
- **Comment** – the text comment to describe the device

The list of the variables to be requested by the master is in the lower part of the window. Each variable created in this list can be found in the variable table under the tab **Network, Slot X** (sect. 5.5).

Add a variable by clicking the icon **+** **New variable** and set its properties.

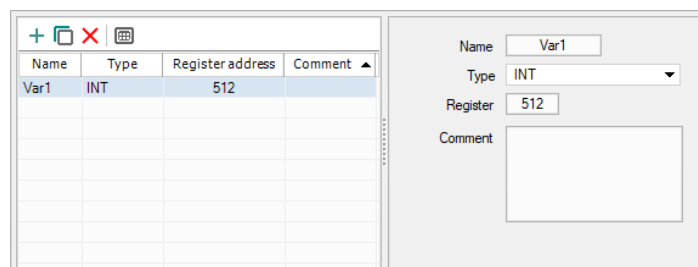



Fig. 4.19 Variable configuration in slave mode

- **Name** – the name of the variable
- **Type** – the data type of the variable: BOOL, INT or REAL
- **Register** – the register address. The range of the available addresses is specified in the device user guide.
- **Comment** – the text comment to describe the requested variable

Device configuration

To create several variables with the same settings, select a variable and click the icon  **Duplicate**.

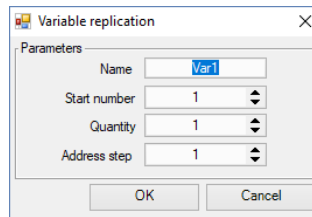



Fig. 4.20 Variable duplication

- **Name** – the name of the duplicated variable
- **Start number** – the initial number added to the name of the duplicated variable
- **Quantity** – the quantity of the duplicated variables
- **Address step** – the address increment

Click **OK** to add the duplicated variables to the list of variables. The variables will be stored in adjacent register cells with consecutive addresses.

To remove the variable from the list, use the icon  **Delete**.

4.4 Extension modules

Up to two I/O extension modules of type PRM can be connected to PR200. For further information about extension modules refer to the PRM user guide.

To use module I/O points in the circuit program, add the module to the group **Extension modules** using its context menu (Fig. 4.21).

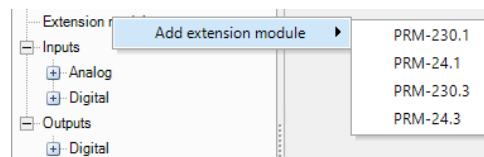

Fig. 4.21

The additional I/O points of the added modules can be configured in branches **Inputs** and **Outputs** respectively (sect. 4.5, 4.6). They are displayed in the tree as **Ix(y)** and **Qx(y)** respectively, where **x** is the ordinal number of the I/O points on the module and **y** is the ordinal number of the module counting from the basic device.

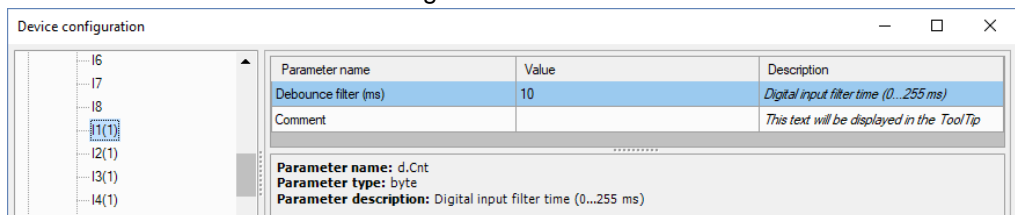

Fig. 4.22

Before uploading the project to the basic device, all modules must be connected via the internal bus to PR200 and powered on. The module firmware is synchronized with the current version of ALP when project uploading.

4.5 Inputs

The content of the branch **Inputs** depends on the resources of the target device. It can be analog and/or digital inputs (Fig. 4.23, 4.24).

Device configuration

The parameter **Comment** is common for all types of inputs. The text in this field is displayed in a tooltip, when the mouse is over the input in the workspace. The text can be entered in Property Box too.

For further details about the configuration of the inputs, refer to the device user guide.

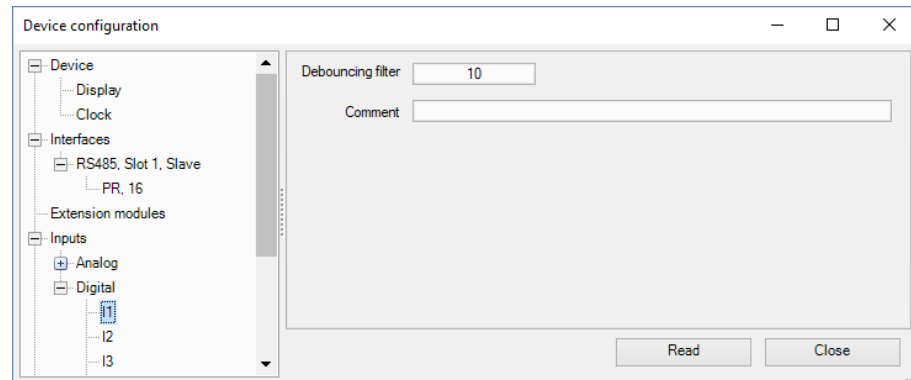

Fig. 4.23 PR200 digital input configuration

Other input parameters depend on the types of the input and the device.

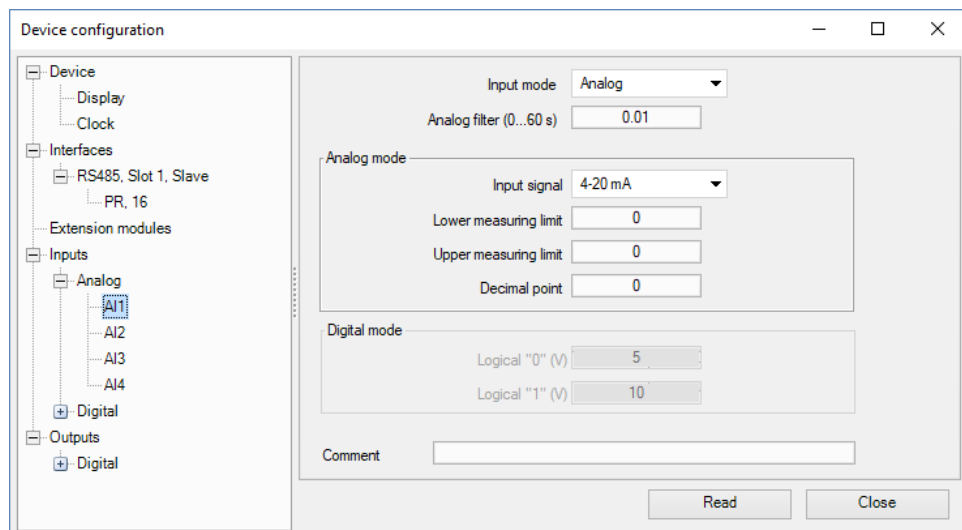

Fig. 4.24 PR200 analog input configuration

4.6 Outputs

The content of the branch **Outputs** depends on the resources of the target device. It can be analog and/or digital outputs (Fig. 4.24).

The parameter **Comment** is common for all types of outputs. The text in this field is displayed in a tooltip, when the mouse is over the output in the workspace. It can be entered in Property Box too.

For further details about the configuration of the outputs, refer to the device user guide.

The digital outputs of the extension module have an additional parameter **Safe condition**. The parameter specifies the output state in case the connection between the module and the basic device is lost.

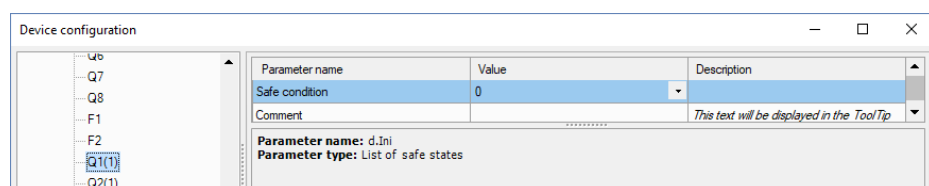

Fig. 4.25 PRM input configuration

Device configuration

4.7 Calibration

Only general information about calibration of analog inputs or outputs is given in this section. For detailed information about calibration refer to the user guide of the device.

If calibration of analog inputs or outputs is necessary, use the menu item **Device > Calibration....**

The item is active only if a device is connected. Select the calibration target (inputs or outputs) in the opened dialog.

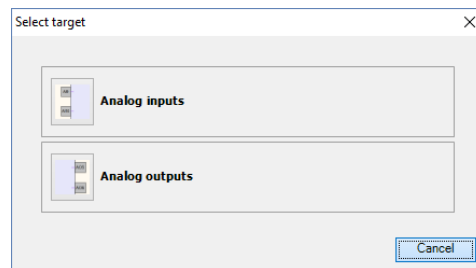

Fig. 4.26

After the calibration target selection, the execution of the program in the device is stopped. The program starts again upon the successful completion of the calibration.

4.7.1 Input calibration

To calibrate inputs, connect a reference signal source to them. Start calibration, select the type of signal connected to the input and set the calibration parameters in the opened dialog.

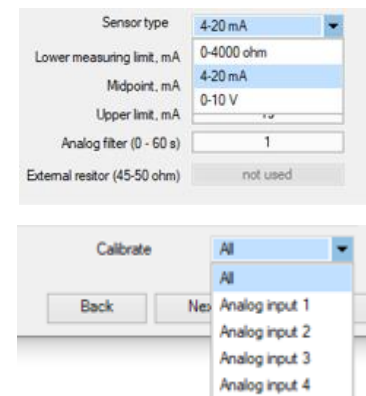
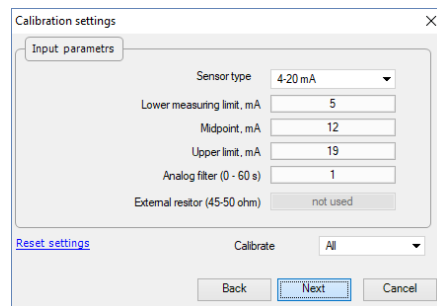

Fig. 4.27 PR200 input calibration

Use the item **Reset settings** to apply the default settings for calibration.

Use the list **Select input** to select the input to calibrate, click the button **Next** and follow the instructions.

4.7.2 Output calibration

Before calibrating an analog output, prepare the appropriate measuring device, than start calibration and follow the instructions. Measure the signal at the output indicated at the top right of the window and enter the value in the input field.

Device configuration

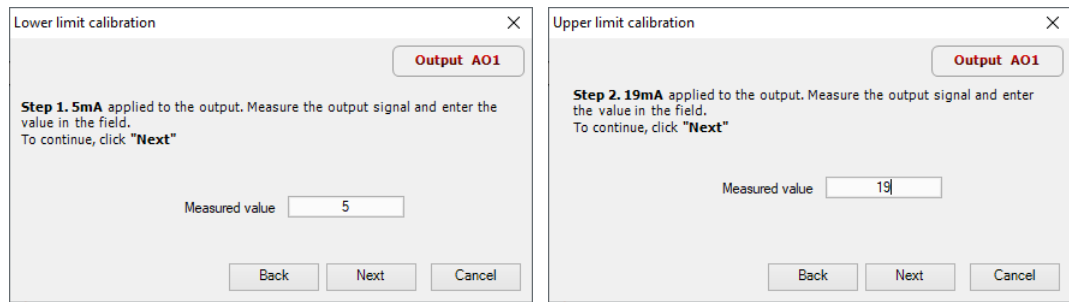

Fig. 4.28 PR200 output calibration

Proceed the same way with the other outputs if needed. The message about the calibration results will appear after the completion of the calibration.

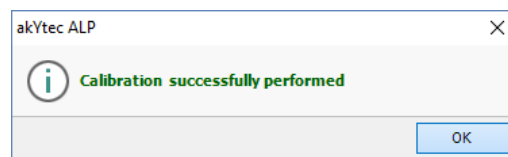

Fig. 4.29

4.8 Change target device

The target device of a project can be changed using the menu item **File > Change target device**. A list of devices to which you can transfer the project appears. Select the device and confirm with **OK**. Check and repair broken links, if any. The program can be checked using simulation (sect. 7.11). Save the modified project.

Consider the replacement rules:

1. The workspace size will be automatically adjusted to the changed number of I/O points.
2. User-configured layout of I/O points remains. New I/O points will be placed after existing I/O points of the original project.
3. The connections of I/O points whose data type has been changed will be removed.
4. If the number of I/O points becomes less than in the original project, the connections of the removed I/O points will be also removed.
5. If there were extension modules in the original project, they will be transferred to the new configuration with their connections.
6. Settings of analog I/O points will be transferred if there are analog I/O points on the new device.
7. Network interfaces will be transferred unchanged.
8. Display settings will be transferred unchanged.
9. Variables will be transferred unchanged.

Variables

5 Variables

To see all project variables, click the icon  in the toolbar or use the menu item **Device > Variable table**.

The variables are divided into three groups, each of which has a separate tab in the table:

- Standard (sect. 5.3)
- Service (sect. 5.4)
- Network (sect. 5.5)

Standard and network variables can be created, duplicated or deleted. The duplicated variable is a copy of the selected variable saved in the next free register cell. Consecutive indexes, starting with 2, will be added to the name of each duplicated variable.

To create a new variable, you can use:

- toolbar icon 
- key combination **Ctrl+N**

or simply write a new variable name in the last row.

If you create a new variable after an unsuccessful search, the name entered in the search field will be proposed as the name of the new variable.

To duplicate an existent variable you can use:

- toolbar icon 
- key combination **Ctrl+D**
- context menu item **Duplicate**

To delete a variable, you can use:

- toolbar icon 
- key **DEL**
- context menu item **Delete**

Service variables can neither be created nor deleted.

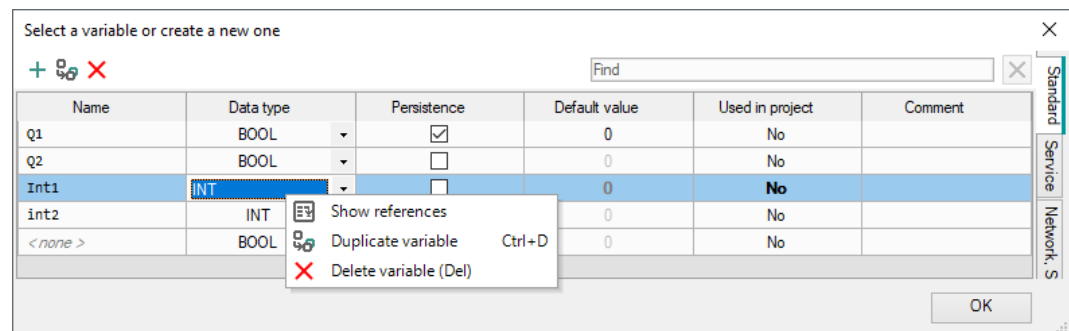

Fig. 5.1

The rows in the Variable Table can be sorted by each column.

5.1 Properties

Table 5.1 Variable properties

Name	The name of the variable
Data type	BOOL, INT or REAL (sect. 5.2)
Persistence	Only for standard variables available. The variable is stored in the non-volatile memory of the device and become retain variable . For detailed information about storage time and memory size, refer to the device user guide.
Default value	Only for retain and network variables available. It is the value at the first start of the program, until the new value is assigned to.

Variables

Used in project	The variable has a reference to a block in the program
Comment	The text displayed in a tooltip in the workspace, when the mouse is over the variable

5.2 Data type

The variables of the following types can be used in a program:

- Boolean (**BOOL**)
- Integer (**INT**)
- Real (**REAL**)

Note: Different devices can have restrictions related to support of certain types of variables.

1. BOOL

A variable of this type has only two possible values: 1 (**True**) or 0 (**False**).

The connecting lines between the BOOL variables in the circuit program are displayed in gray.

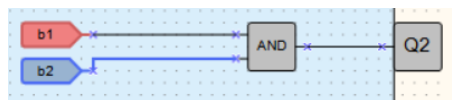

Fig. 5.2 BOOL connections

2. INT

A variable of this type is unsigned integer in the range 0...4,294,967,295 (4 Byte).

The connecting lines between the INT variables in the circuit program are displayed in red.

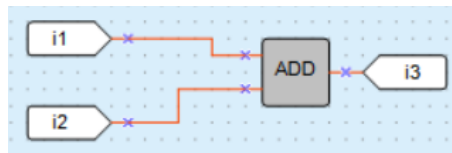

Fig. 5.3 INT connections

3. REAL

A variable of this type has a value in the range $-3.402823e+38 \dots 3.402823e+38$. It is represented by a floating-point number of single-precision (4 Byte).

The connecting lines between the REAL variables in the circuit program are displayed in violet.

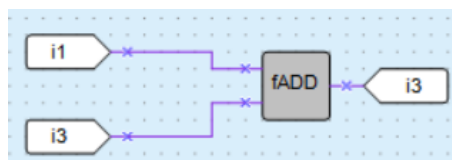

Fig. 5.4 REAL connections

5.3 Standard variables

These are common variables used for data exchange between blocks of the circuit program, inputs, outputs and display forms.

Standard variables are listed in the variable table under the tab **Standard**.

Variables

To create a variable, select the empty row in the table, enter the variable name and select its data type. Other parameters are optional. The created variable can be used in the project.

Use the item **Show references** in the variable context menu to see where the variable is used in the project.

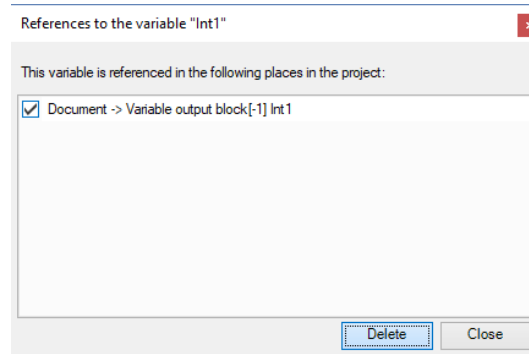

Fig. 5.5

In the dialog window **References to the variable** select the reference you want to delete and click **Delete**.

To remove the variable from the table, use the item **Delete variable** in its context menu.

5.4 Service variables

Service variables are associated with the device settings and can differ, depending on the device. Service variables are related to the hardware features, such as real-time clock, interface card in the slot etc. and cannot be deleted. Access rights to service variables may be limited.

The service variables are listed in the variable table under the tab **Service**.

The blocks of service variables are shown in the circuit program with a gray background.

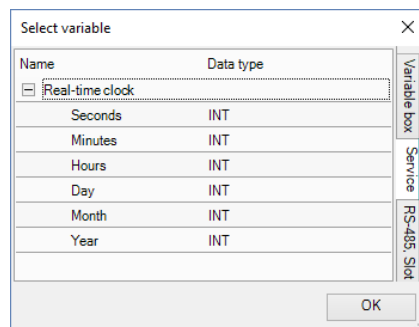

Fig. 5.6 Service variables in the table

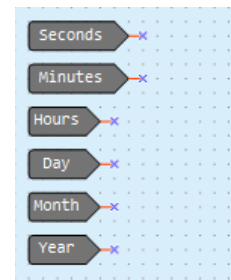

Fig. 5.7 Service variables in diagram

5.5 Network variables

Each interface slot has a separate tab in the table.

If the interface is configured as a master, there are separate tabs for each Slave device within the slot tab (Fig. 5.8). The Slave tab contains the variables to be requested for this Slave device.

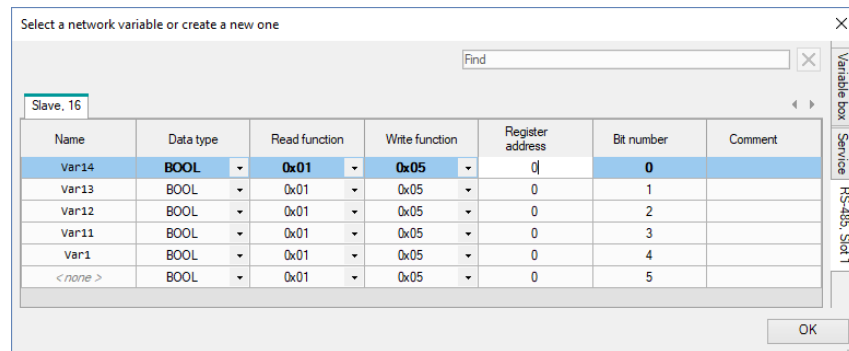

Fig. 5.8 Network variables for master interface

Network variables and their references are deleted in the same way as standard variables (sect. 5.3).

For more details about network variables for master interface see sect. 4.3.3.1.

If the interface is configured as a Slave, all network variables to be requested by the master are shown in one list (Fig. 5.9). For more details about network variables for Slave interface see sect. 4.3.3.3.

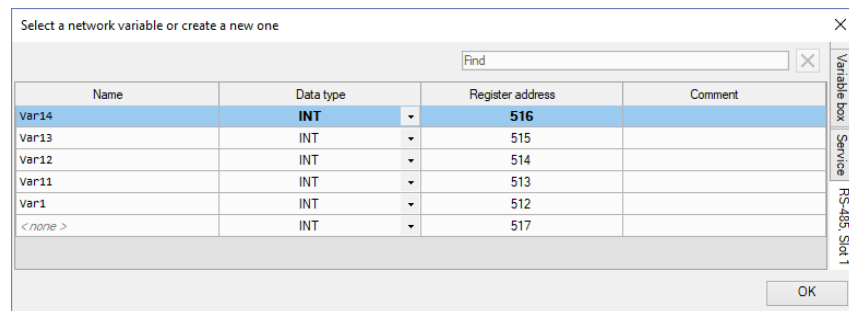



Fig. 5.9 Network variables for Slave interface

5.6 Copy / paste variable block

The variable blocks can be copied and pasted into another project.

To copy a variable block, select it in the workspace and use the toolbar icon  or the item **Copy** in the block context menu.

To paste a variable block into another project, open it in the second ALP instance and use the toolbar icon  or the item **Paste** in the workspace context menu.

Copy rules for all variables associated with the block:

- If the variable associated with the block is unique in the second project, it will be added with all properties to the variable table.
- If there is an identical variable in the second project, it will be associated with the pasted block. No new variables will be added to the variable table.
- If the second project has a variable with the same name but different parameters, a new variable will be created. To resolve the naming conflict, the name of one of the variables should be changed manually.
- It is not possible to insert variables of REAL type into a project for a target device that does not support REAL data type.
- Retain (persistent) variables cannot be copied into a project for a target device that does not support them.

Copy rules for service variables:

- Service variables cannot be copied to a project written to a target device without a real-time clock.

Variables

Copy rules for network variables:

- Only the variables of a slave interfaces can be copied into another project and the interfaces in both projects must have the same slot numbers. The variables of the master interface variables should be created manually.
- Any register conflict must be resolved manually.

Library

6 Library

If a project is open, the panel **Library Box** contains the following libraries:

- **Functions**
- **Function blocks**
- **Project macros**

Select an icon in the lower part of the panel to show the respective content.

The library **Project macros** comprises the macros that have been created, imported or included to the project from Online Database.

View options can be changed using the icons located in the toolbar of the panel.

6.1 Functions

The library contains the following function groups:

- Logical operators
- Mathematical operators
- Relational operators
- Bitshift operators
- Bit operators

6.1.1 Logical operators

- Conjunction (AND)
- Disjunction (OR)
- Negation (NOT)
- Exclusive OR (XOR)

The logical operators can operate with BOOL or INT variables.

If the input values are INT, the operation is bitwise performed and the output is also an INT.

6.1.1.1 Conjunction (AND)

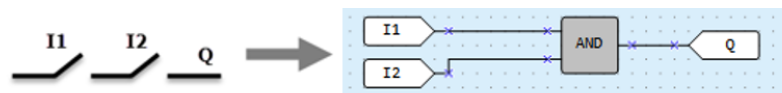

Fig. 6.1

The output **Q** is **True** if both inputs are **True**. The function **AND** represents a serial connection in an electrical circuit.

Table 6.1 Truth table

I1	I2	Q
0	0	0
0	1	0
1	0	0
1	1	1

Bitwise operation example with integer inputs:

```

0101 (decimal 5)
AND 0011 (decimal 3)
=   0001 (decimal 1)

```

Library

6.1.1.2 Disjunction (OR)

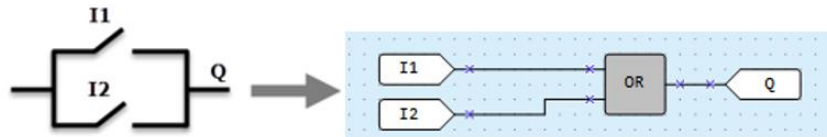

Fig. 6.2

The output **Q** is **True** if at least one of the inputs is **True**. The function **OR** represents a parallel connection in an electrical circuit.

Table 6.2 Truth table

I1	I2	Q
0	0	0
0	1	1
1	0	1
1	1	1

Bitwise operation example with integer inputs:

```

0101 (decimal 5)
OR 0011 (decimal 3)
= 0111 (decimal 7)
    
```

6.1.1.3 Negation (NOT)

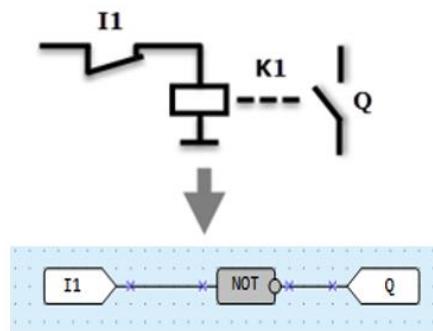

Fig. 6.3

The function **NOT** inverts the signal. The output **Q** is **True** if the input is **False** and vice versa.

Table 6.3 Truth table

I1	Q
0	1
1	0

Bitwise operation example with integer inputs:

```

NOT 0111 (decimal 7)
= 1000 (decimal 8)
    
```

The bitwise NOT, or complement, is a unary operation that performs logical negation on each bit, forming the ones' complement of the given binary value.

Library

6.1.1.4 Exclusive OR (XOR)

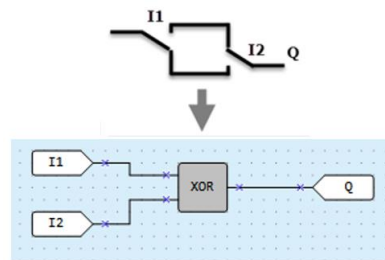

Fig. 6.4

The output **Q** is **True** if only one of the inputs is **True**.

Table 6.4 Truth table

I1	I2	Q
0	0	0
0	1	1
1	0	1
1	1	0

Bitwise operation example with integer inputs:

```

0101 (decimal 5)
XOR 0011 (decimal 3)
=    0110 (decimal 6)
    
```

6.1.2 Mathematical operators

There are different operators for different data types:

Table 6.5

Operator	INT	REAL
Addition	ADD	fADD
Subtraction	SUB	fSUB
Multiplication	MUL	fMUL
Division	DIV	fDIV
Modulo operation	MOD	-
Power function	-	fPOW
Absolute value	-	fABS

6.1.2.1 Addition (ADD, fADD)

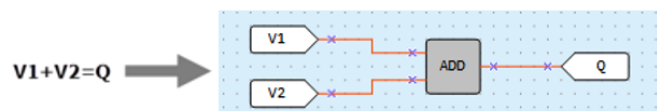

Fig. 6.5

The function **ADD** operates with INT variables, the function **fADD** operates with REAL variables.

The output value **Q** is the sum of the input values.

Example:

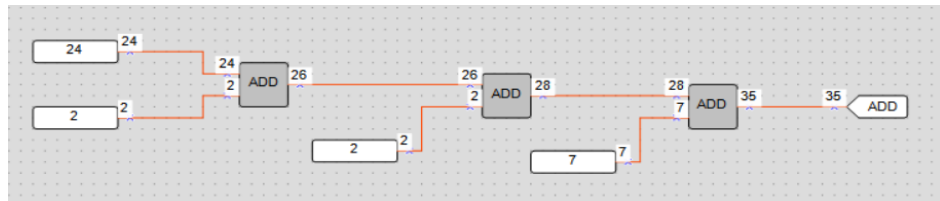

Fig. 6.6

The output value may not exceed 4294967295 (32 bits). Otherwise the extra bits will be truncated.

6.1.2.2 Subtraction (SUB, fSUB)



Fig. 6.7

The function **SUB** operates with INT variables, the function **fSUB** operates with REAL variables.

The output value **Q** is the result of subtraction of the value **I2** from the value **I1**.

Example 1:

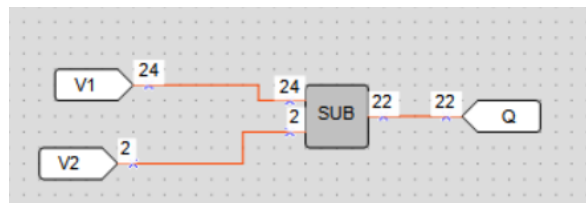

Fig. 6.8

If the value **I1** is less than the value **I2**, the output is calculated as follows:

$$Q = I1 + 0x100000000 - I2$$

$$0x100000000 = 4294967296$$

Example 2:

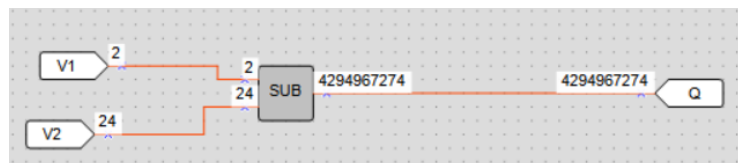

Fig. 6.9

6.1.2.3 Multiplication (MUL, fMUL)

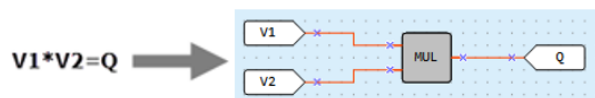

Fig. 6.10

The function **MUL** operates with INT variables, the function **fMUL** operates with REAL variables.

The output value **Q** is the product of the input values.

Example:

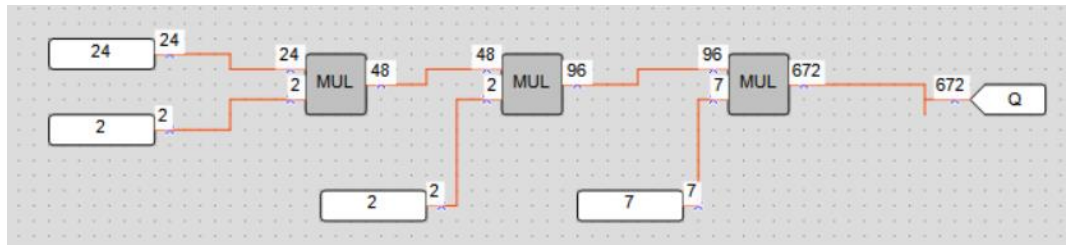

Fig. 6.11

The output value may not exceed 4294967295 (32 bits). If it does happen, the extra bits will be truncated.

6.1.2.4 Division (DIV, fDIV)

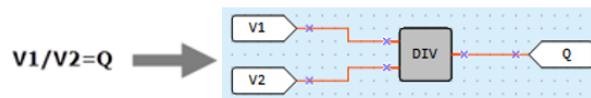

Fig. 6.12

The function **DIV** operates with INT variables, the function **fDIV** operates with REAL variables.

The output value **Q** is the quotient of the input values, where the value **I1** is the dividend and the value **I2** is the divisor.

If the quotient is not an INT, it is rounded down to an INT.

In case of division by 0 the output value is 0xFFFFFFFF.

6.1.2.5 Modulo operation (MOD)

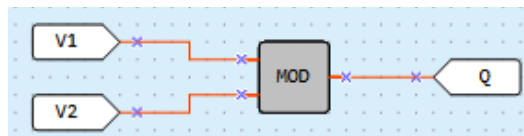

Fig. 6.13

The function **MOD** operates with INT variables. The output **Q** is a remainder of the division of input values.

$$Q = \left[\frac{V1}{V2} \right]$$

Example:

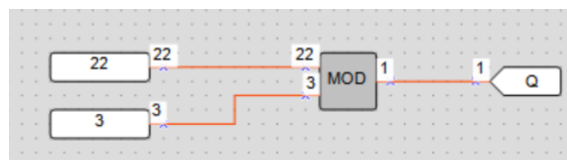

Fig. 6.14

6.1.2.6 REAL-Power function (fPOW)

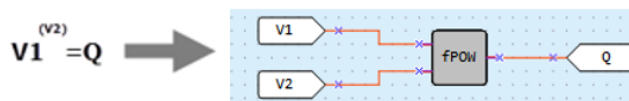

Fig. 6.15

The function **fPOW** operates with REAL variables.

Library

The output value **Q** is the value **I1** raised to the power of the value **I2**.

Example:

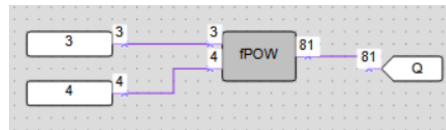

Fig. 6.16

6.1.2.7 REAL-Absolute function (fABS)



Fig. 6.17

The function **fABS** operates with REAL variables.

The output value **Q** is an absolute value of the input value.

$$Q = |V|$$

Examples:

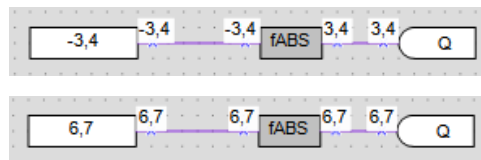

Fig. 6.18

6.1.3 Relational operators

The relational operators are functions that test or define some kind of relation between two or more values.

6.1.3.1 Equal (EQ)

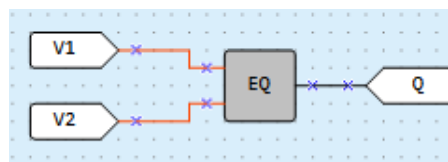

Fig. 6.19

The function **EQ** operates with INT variables.

The output value **Q** is **True** if the value **I1** and the value **I2** are equal.

Table 6.6 Truth table

I1 / I2	Q
I1 = I2	1
I1 > I2	0
I1 < I2	0

Examples:

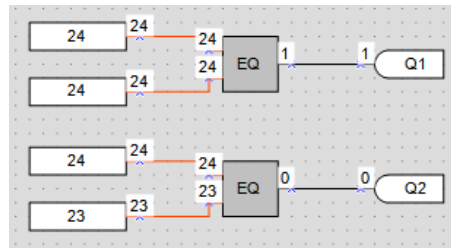

Fig. 6.20

6.1.3.2 Greater than (GT, fGT)

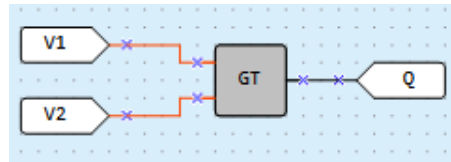

Fig. 6.21

The function **GT** operates with INT variables, the function **fGT** operates with REAL variables.

The output value **Q** is **True** if the value **I1** is greater than the value **I2**.

Table 6.7 Truth table

I1 / I2	Q
I1 = I2	0
I1 > I2	1
I1 < I2	0

Examples:

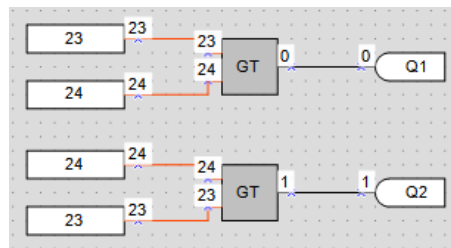

Fig. 6.22

6.1.3.3 Binary selection (SEL)

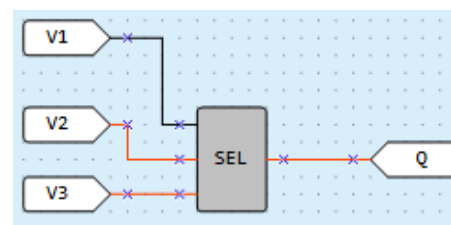

Fig. 6.23

The function **SEL** operates with INT variables, the function **fSEL** operates with REAL variables.

If **I1 = False**, the output value **Q** is set to the value **I2**, else to the value **I3**.

Library

Table 6.8 Table of states

I1	Q
0	I2
1	I3

Examples:

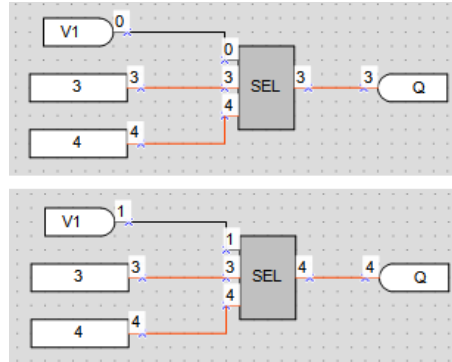

Fig. 6.24

6.1.4 Bitshift operators

The bitshift operators treat a variable as a series of bits that can be moved (shifted) to the left or right.

6.1.4.1 Shift register left (SHL)

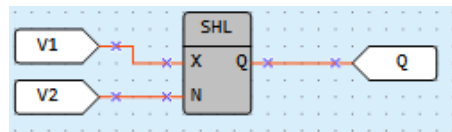

Fig. 6.25

The function **SHL** operates with INT variables. It is used to shift all bits of the operand **X** to the left by the **N** number of bits; vacated bits are zero-filled. The result is set to the output **Q**.

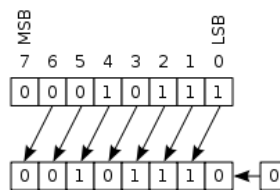

Fig. 6.26

Example: left shift of the number 38 (decimal) = 00100110 (binary) by 2 bits

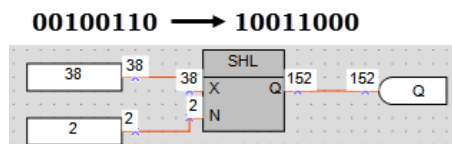

Fig. 6.27

6.1.4.2 Shift register right (SHR)

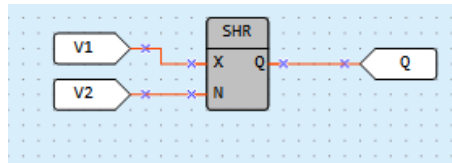

Fig. 6.28

The function **SHR** operates with INT variables. It is used to shift all bits of the operand **X** to the right by the **N** number of bits; vacated bits are zero-filled. The result is set to the output **Q**.

Example: right shift of the number 152 (decimal) = 10011000 (binary) by 2 bits

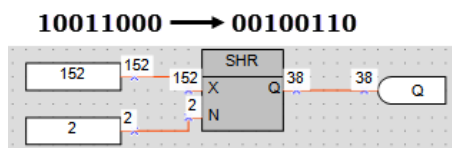

Fig. 6.29

6.1.5 Bit operators

The bit operator treats a value as a series of bits to perform operations on one or more individual bits of an operand.

6.1.5.1 Read single bit (EXTRACT)

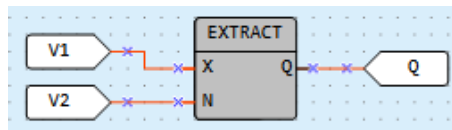

Fig. 6.30

The output value **Q** (BOOL) of the function **EXTRACT** is the value of bit **N** (INT) in the operand **X** (INT). The bit numbering is zero-based.

Example: reading of the 5th bit from the number 81 (decimal) = 1010001 (binary):

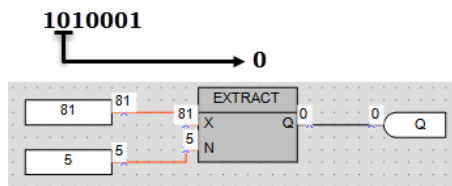

Fig. 6.31

6.1.5.2 Set single bit (PUTBIT)

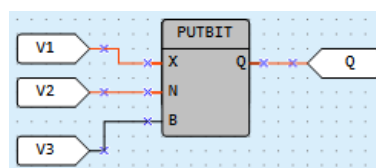

Fig. 6.32

This output value **Q** (INT) is the value of the operand **X** (INT) where the bit **N** (INT) is set to the value at the input **B** (BOOL). The bit numbering is zero-based.

Example: setting of the 4th bit to 1 in the number 38 (decimal) = 100110 (binary):

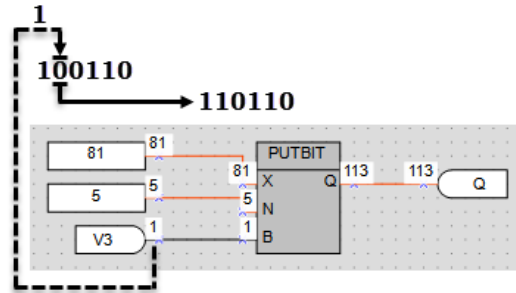

Fig. 6.33

6.1.5.3 Decoder (DC32)

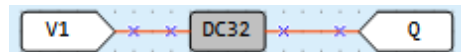

Fig. 6.34

The decoder converts a binary code at the input to a position code at the output. Decoding is carried out bitwise by the logical operation **AND** with the operand 0x1F (11111b).

Table 6.9 Truth table

Binary code					Position code								
5	4	3	2	1	32	31		6	5	4	3	2	1
0	0	0	0	0	0	0	...	0	0	0	0	0	1
0	0	0	0	1	0	0		0	0	0	0	1	0
0	0	0	1	0	0	0		0	0	0	1	0	0
0	0	0	1	1	0	0		0	0	1	0	0	0
0	0	1	0	0	0	0		0	0	1	0	0	0
0	0	1	1	0	0	0		0	0	1	1	0	0
...									
1	1	1	0	1	0	0		0	0	0	0	0	0
1	1	1	1	0	0	1		0	0	0	0	0	0
1	1	1	1	1	1	0		0	0	0	0	0	0

Example:

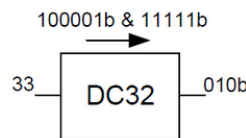

Fig. 6.35

6.1.5.4 Encoder (CD32)



Fig. 6.36

The encoder converts a position code at the input to a binary code at the output. If there is more than one "1" bits in the position code, the encoder operates only with the most significant "1" bit. For truth table see table 6.9 for Decoder.

Library

6.2 Function blocks

The library contains the following FB groups:

- Triggers
- Timers
- Generators
- Counters
- Control

6.2.1 Triggers

- RS trigger reset dominant (RS)
- SR trigger set dominant (SR)
- Rising edge (RTRIG)
- Falling edge (FTRIG)
- D-trigger (DTRIG)

6.2.1.1 RS trigger reset dominant (RS)

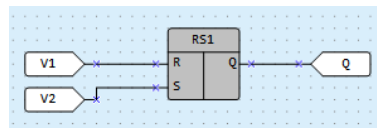

Fig. 6.37

The output **Q** is **True** with a rising edge at the input **S** (Set) and **False** with a rising edge at the input **R** (Reset). The input **R** has higher priority.

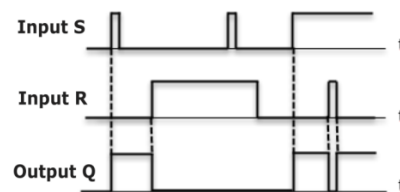

Fig. 6.38

6.2.1.2 SR trigger set dominant (SR)

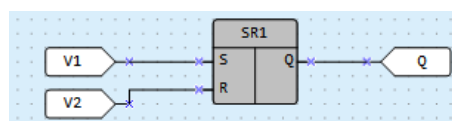

Fig. 6.39

The output **Q** is **True** with a rising edge at the input **S** (Set) and **False** with a rising edge at the input **R** (Reset). The input **S** has higher priority.

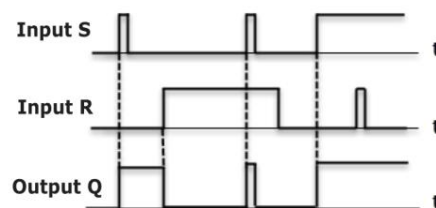

Fig. 6.40

6.2.1.3 Rising edge (RTRIG)

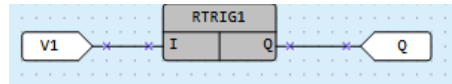

Fig. 6.41

Detector for a rising edge

The output **Q** remains **False** until a rising edge at the input **I**. As soon as the input **I** becomes **True**, the output becomes also **True** and remains for one program cycle.

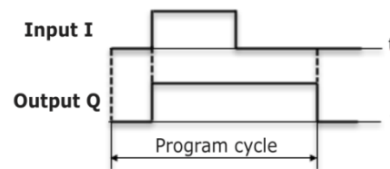

Fig. 6.42

6.2.1.4 Falling edge (FTRIG)

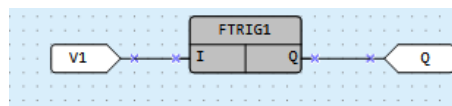

Fig. 6.43

Detector for a falling edge

The output **Q** remains **False** until a falling edge at the input **I**. As soon as the input **I** becomes **False**, the output becomes **True** and remains for one program cycle.

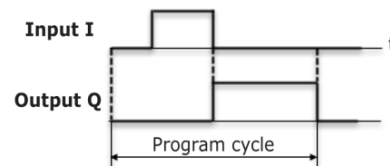

Fig. 6.44

6.2.1.5 D-trigger (DTRIG)

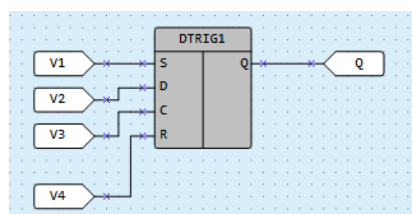

Fig. 6.45

D-trigger generates a pulse at the output **Q** with the pulse duration specified at the input **D** and synchronized with the clock pulse at the input **C**.

If the input **D** is **True**, the output **Q** becomes **True** with a rising edge of the clock pulse at the input **C**.

If the input **D** is **False**, the output **Q** becomes **False** with a rising edge of the clock pulse at the input **C**.

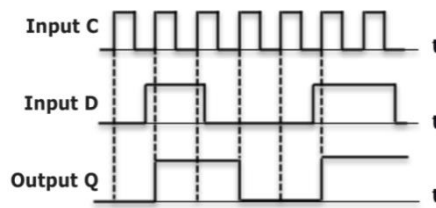

Fig. 6.46

The output **Q** can be forced set to **True** with a rising edge at the input **S** (Set) and forced reset to **False** with a rising edge at the input **R** (Reset), regardless of the states of the inputs **C** and **D**. The input **R** has higher priority.

6.2.2 Timers

- Pulse (TP)
- ON-delay timer (TON)
- OFF-delay timer (TOF)
- Timer (CLOCK)
- Weekly timer (CLOCKW)

6.2.2.1 Pulse (TP)

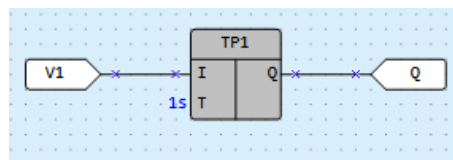

Fig. 6.47

The block **TP** is used to generate one output pulse with the specified pulse duration.

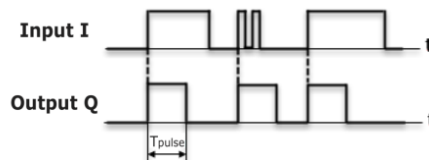

Fig. 6.48

The output **Q** becomes **True** with a rising edge at the input **I** for the time specified at the input **T**. During this time, the output **Q** remains **True** regardless of the signal change at the input **I**. The output **Q** is reset to **False** with the end of pulse.

The pulse duration and the time unit can be set in Property Box.

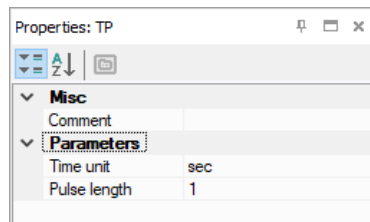

Fig. 6.49

Time range: 0...4147200000 ms or 48 days.

6.2.2.2 ON-delay timer (TON)

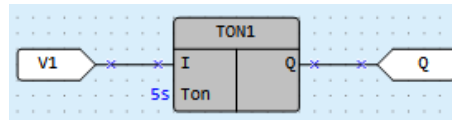

Fig. 6.50

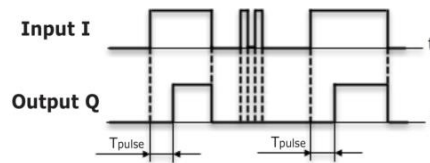

Fig. 6.51

The output **Q = False** if the input **I = False**. The delay time specified at the input **T_{ON}** starts with a rising edge at the input **I**. When the time **T_{ON}** is elapsed, the output **Q** becomes **True** and remains until a falling edge at the input **I**. Input changes shorter than **T_{ON}** are ignored.

The delay time and the time unit can be set in Property Box.

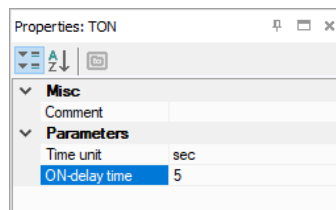

Fig. 6.52

Time range: 0...4147200000 ms or 48 days.

6.2.2.3 OFF-delay timer (TOF)

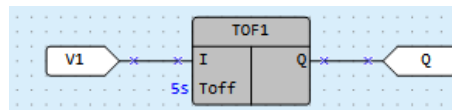

Fig. 6.53

The output **Q = False** if the input **I = True**. The delay time specified at the input **T_{OFF}** starts with a falling edge at the input **I**. When the time **T_{OFF}** is elapsed, the output **Q** becomes **False** and remains until a rising edge at the input **I**. Input changes shorter than **T_{OFF}** are ignored.

The delay time and the time unit can be set in Property Box.

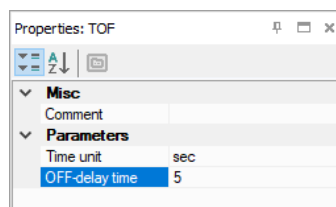

Fig. 6.54

Time range: 0...4147200000 ms or 48 days.

Library

6.2.2.4 Timer (CLOCK)

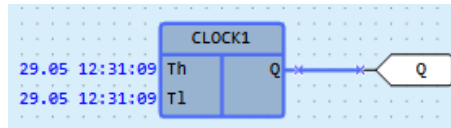

Fig. 6.55

The block **CLOCK** is an interval timer controlled by a real-time clock.

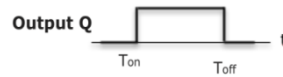

Fig. 6.56

The times T_H and T_L can be set in Property Box.

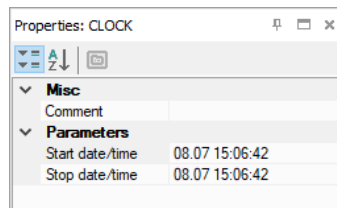

Fig. 6.57

Time range: from 0.00 seconds to 24 hours.

If $T_H < T_L$, the state of the output **Q** is as follows:

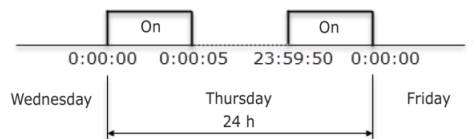

Fig. 6.58

6.2.2.5 Week timer (CLOCKW)

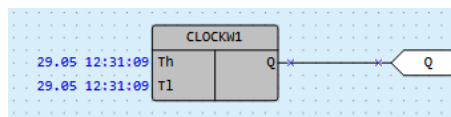

Fig. 6.59

The block **CLOCKW** is an interval timer with the parameter **Weekday** controlled by a real-time clock.

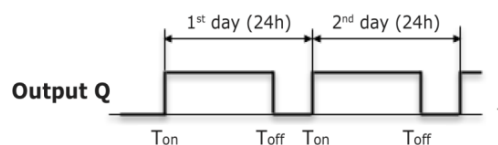

Fig. 6.60

The times T_H and T_L can be set in Property Box.

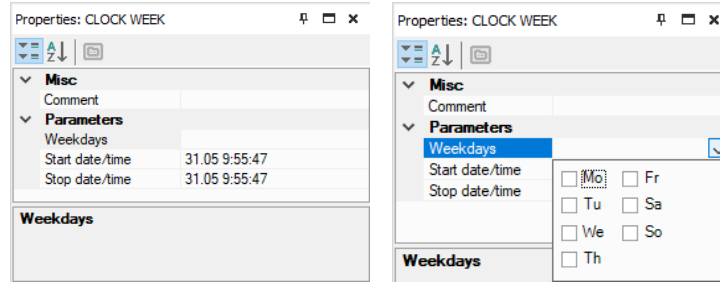

Fig. 6.61

Time range: from 0.00 seconds to 24 hours.

6.2.3 Generators

- Pulse generator (BLINK)

6.2.3.1 Pulse generator (BLINK)

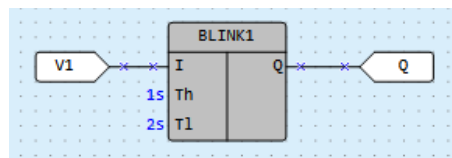

Fig. 6.62

If the input **I** becomes **True**, the block **BLINK** generates a square wave on the output **Q** with a period of $T_H + T_L$, starting with an interval of the duration of T_L , followed by a pulse of the duration of T_H . It continues that way until the input **I** is **False**.

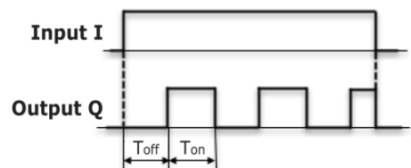

Fig. 6.63

The times T_H and T_L and the time units can be set in Property Box.

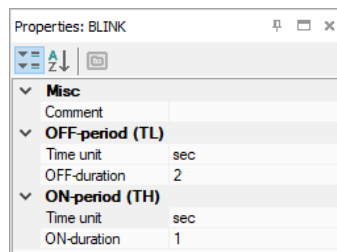

Fig. 6.64

Time range: 0...4233600000 milliseconds or 49 days.

6.2.4 Counters

- Threshold counter with self-reset (CT)
- Universal counter (CTN)
- Threshold counter (CTU)

6.2.4.1 Threshold counter with self-reset (CT)

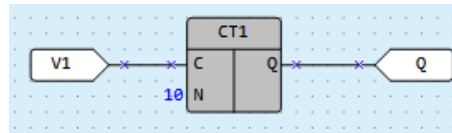

Fig. 6.65

The output **Q** is of type **BOOL**. If the number of pulses counted on the input **C** exceeds the threshold (**Setting**) specified at the input **N**, the output **Q** becomes **True** and remains for one program cycle.

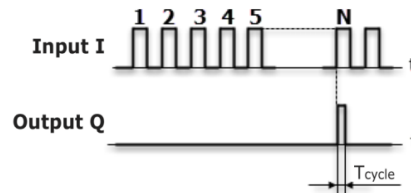

Fig. 6.66

The parameters **Setting** and **State saving** can be set in Property Box.

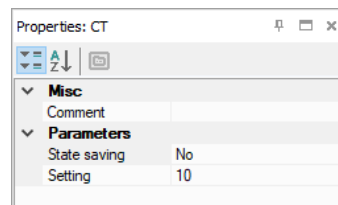

Fig. 6.67

Threshold range: 0...65535.

If **State saving** = **Yes**, the state of the counter is permanently stored in the non-volatile memory.

6.2.4.2 Universal counter (CTN)

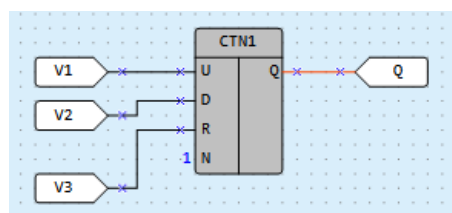

Fig. 6.68

The output **Q** is of type **INT**. A rising edge at the input **U** increases the value at the output **Q** by 1. A rising edge at the input **D** decreases the value at the output **Q** by 1.

If the input **R** = **True**, the output **Q** becomes the value **Setting** at the input **N**.

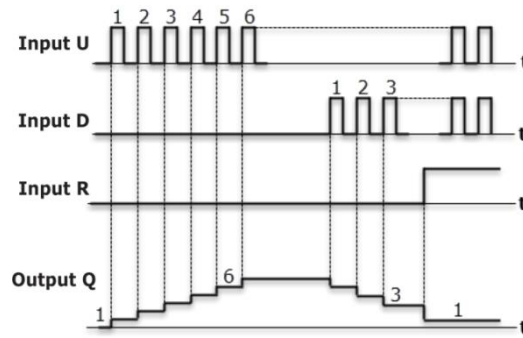

Fig. 6.69

The input **U** has higher priority than the input **D**.

The parameters **Setting** and **State saving** can be set in Property Box.

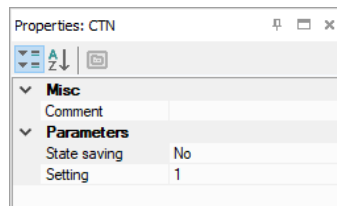

Fig. 6.70

Setting range: 0...65535.

If **State saving** = **Yes**, the state of the counter is permanently stored in the non-volatile memory.

6.2.4.3 Threshold counter (CTU)

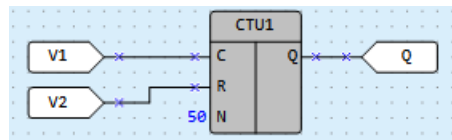

Fig. 6.71

The output **Q** is of type Boolean. If the number of pulses counted on the input **C** exceeds the threshold (**Setting**) specified at the input **N**, the output **Q** becomes **True** and remains until a rising edge at the input **R**. The input **R** has higher priority than the input **C**.

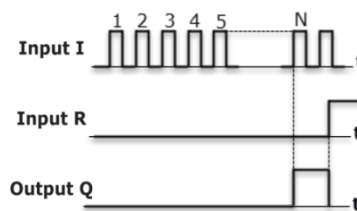

Fig. 6.72

The parameter **Setting** can be set in Property Box.

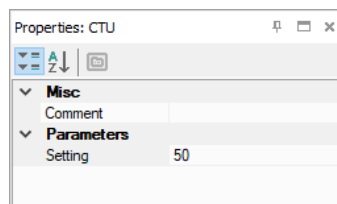

Fig. 6.73

Library

Threshold range: 0...65535.

6.2.5 Analog

- PID controller (PID)

6.2.5.1 PID controller (PID)

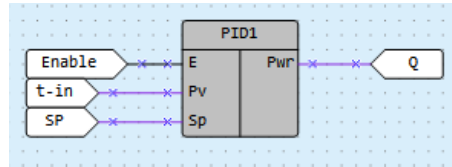

Fig. 6.74

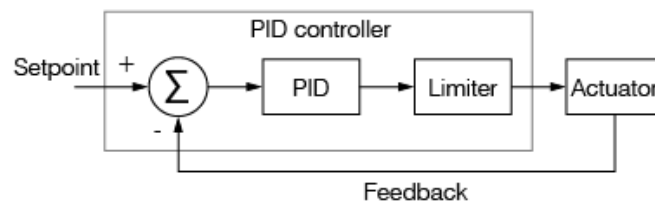

Fig. 6.75

The function block **PID** is used for implementation of the proportional-integral-derivative control.

Table 6.10 PID block inputs/outputs

Name	Type	I/O	Description	Values
E	BOOL	I	Enable control (0 = Off, 1 = On). If disabled, the parameter Pwr takes the value of the parameter Output safe state .	0/1
Pv	REAL	I	Process value	
Sp	REAL	I	Setpoint	
Pwr	REAL	O	Output power, %	0...100

Table 6.11 PID block parameters

Name	Type	Description	Values	Access		
				Property Box	Write ToFB	Read FromFB
Control mode	BOOL	0 – Heating 1 – Cooling	0/1	✓	✓	
Output safe state	REAL	Output value when control is disabled, %	0...100	✓	✓	
Kp	REAL	Proportional gain, multiplication factor for proportional control	0...100	✓	✓	
Ti (s)	REAL	Integral time, time constant for integral control in seconds	-3.402823e+38... 3.402823e+38	✓	✓	
Td (s)	REAL	Derivative time, time constant for derivative control in seconds	-3.402823e+38... 3..402823e+38	✓	✓	
Output max.	REAL	Output upper limit, % (default 80)	0...100	✓	✓	
Output min.	REAL	Output lower limit, % (default 20)	0...100	✓	✓	
Start AT	BOOL	0 – stop auto-tuning 1 – start auto-tuning	0/1		✓	

Name	Type	Description	Values	Access		
				Property Box	Write ToFB	Read FromFB
AT completed	BOOL	Flag: 0 – auto-tuning stopped 1 – auto-tuning started	0/1			✓
Kp calculated	REAL	Calculated proportional gain	0...100			✓
Ti calculated	REAL	Calculated integral time	-3.402823e+38... 3.402823e+38			✓
Td calculated	REAL	Calculated derivative time	-3.402823e+38... 3.402823e+38			✓

Tuning of a control loop is the adjustment of its control parameters (**Kp**, **Ti**, **Td**) to the optimum values for the desired control response.

Programmable tuning

Programmable loop tuning can be performed using the blocks **WriteToFB** ^W and **ReadFromFB** ^R (sect. 7.7).

To write the parameters, use the block WriteToFB (Fig. 6.76) or Property Box (Fig. 6.77).

To read the parameters, use the block ReadFromFB (Fig. 6.76).

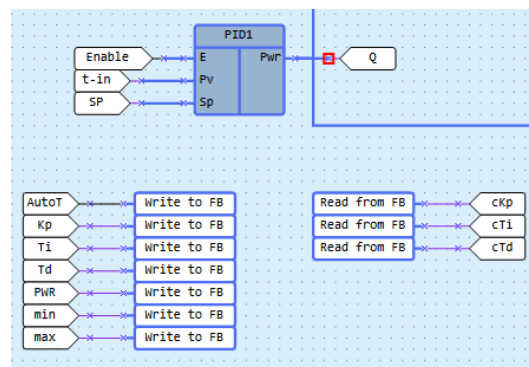

Fig. 6.76

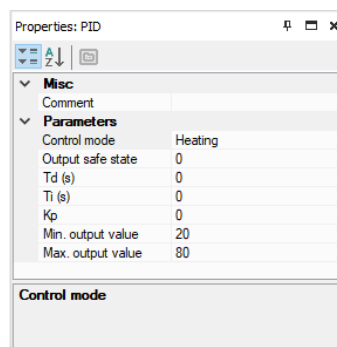

Fig. 6.77

Auto-tuning

To use auto-tuning, add the block WriteToFB to the circuit program and set the reference to the parameter **Start AT** of the PID block.

To start the auto-tuning, enable control (**E = 1**) and set the parameter **Start AT = 1**.

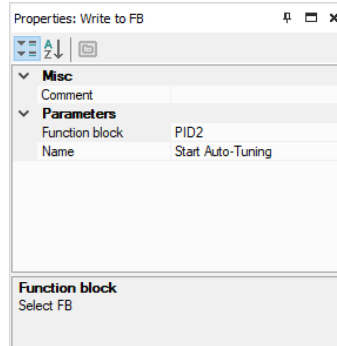

Fig. 6.78

Upon completion of the auto-tuning, the new values of the parameters **Kp**, **Ti** and **Td** are calculated and the flag **AT completed** becomes **1**.

If **Start AT = 0**, the flag **AT completed = 0** as well.

If you set **Start AT = 0** before the completion of auto-tuning, the auto-tuning is stopped, the flag **AT completed** becomes **0** and no new coefficients are calculated.

During the auto-tuning, a test signal limited by parameters **Output max.** and **Output min.** is applied to the output **Pwr**.

Note: If the maximum gain is not sufficient to reach the setpoint, the auto-tuning cannot be completed and will continue until it is stopped with **Start AT = 0**.

6.3 Project macros

Macro is a function block created like a main program in a separate workspace.

To create a new macro:

- use the menu item **File > New macro** (sect. 6.3.3) or
- select blocks in the main workspace and use the item **New macro** from the workspace context menu (sect. 6.3.4)

To use the macro in the project, drag-and-drop it from Library Box into the main workspace.

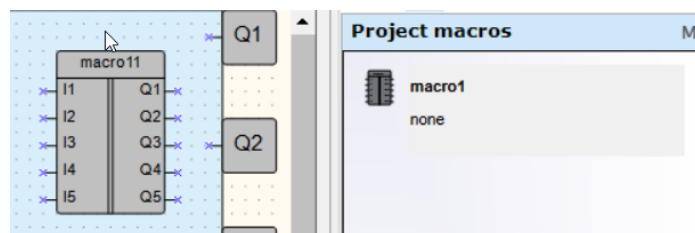

Fig. 6.79

To open the project macro in the separate workspace for editing, select it in the workspace or in the library and use the item **Edit macro** in the macro context menu.

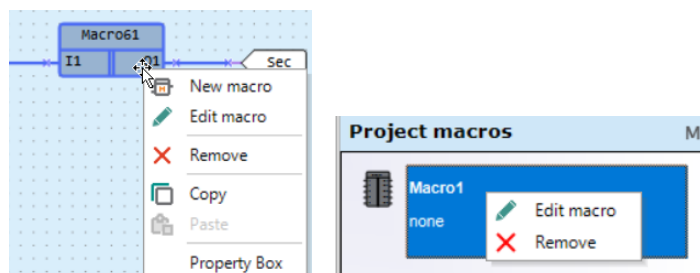

Fig. 6.80

Library

The macro can be saved in the project under another name using the menu item **File > Save macro as...** The saved macro is available only in this project.

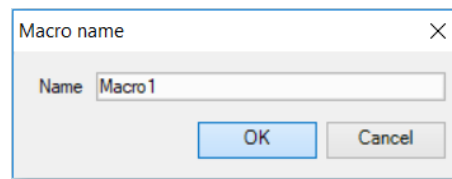

Fig. 6.81

If the macro should be used in other projects, it must be saved as a file i.e. exported, and then imported from this file into another project (sect. 6.3.1).

If a macro used in the project is changed, it will be displayed in red in the program and the user will be prompted to update the macro (sect. 6.3.5).

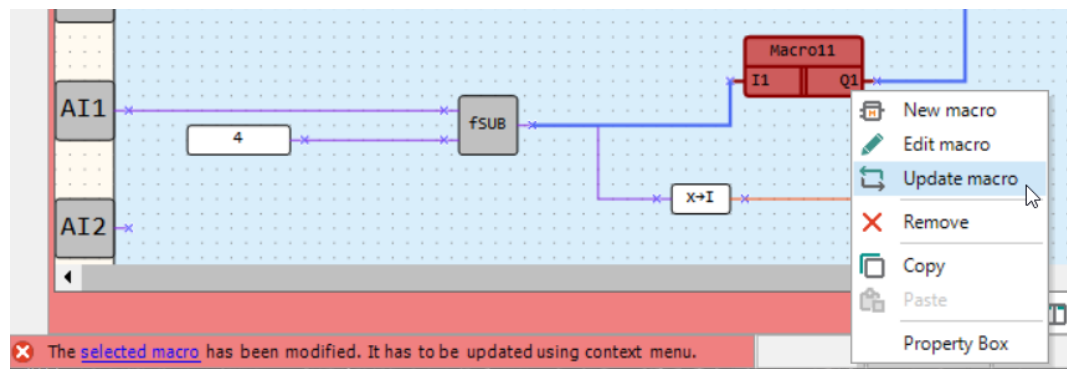

Fig. 6.82 Macro update request

6.3.1 Export, import, download macro

A macro can be exported to a file when the macro workspace is active.

Open the macro for editing, use the menu item **File > Export Macro**, specify the file name and the path and confirm with **OK**. The macro file has the extension ***.tpl**.

A macro can be imported from the file into the library if the main program is active. Use the menu item **File > Import macro**, select the file in the opened dialog and confirm it with **OK**. The macro is added to the library into the section **Macros**.

To download macros from **Online Database**, an internet connection is needed. Select the menu item **File > Component Manager** (the main workspace must be active) to open **Component Manager** in a separate window (sect. 2.9).

6.3.2 FB in macro

If a function block is used in the macro, the user can define whether the FB parameters are available as parameters of the macro in the main program.

If the parameter **Use in macro** is set to **Yes**, the FB parameters became parameters of the macro and a new option **Parameters of macro** is added to the macro. With this option, the user can specify the name for each FB parameter in the macro to use in the main program.

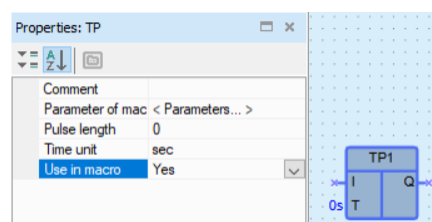

Fig. 6.83

Library

6.3.3 New macro using main menu

Select the item **File > New macro** in the main menu. Specify the number of inputs and outputs in the opened dialog and confirm with **OK**. The new empty macro is opened in a separate workspace.

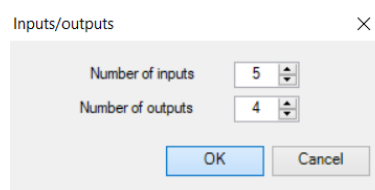

Fig. 6.84

The number of inputs and outputs can be always changed using workspace context menu.

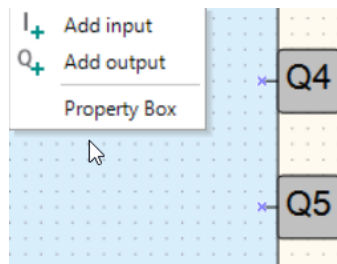

Fig. 6.85

To remove an input or an output, use **Delete** in its context menu.

The data type for each input and output can be selected in Property Box.

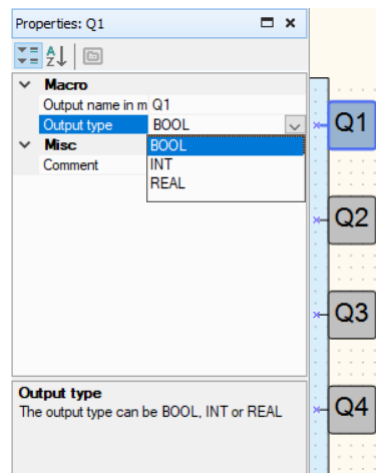

Fig. 6.86

Give a name, a description and a group to the macro in Property Box.

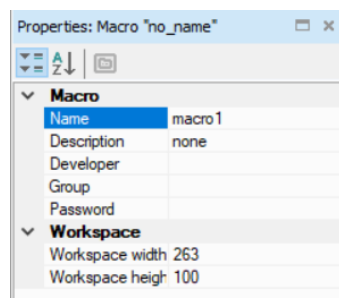

Fig. 6.87

Library

The name is displayed in the workspace tab. It is the name of the macro in the project.

The text in the parameter **Description** is displayed in a tooltip, when the mouse is over the macro in the workspace.

The name in the parameter **Group** is used in the library. If the group name is empty, the macro is assigned to the group **Other** in the project library.

If you set the password for the macro, it will be asked every time the menu item **Edit macro** is selected.

6.3.4 New macro using context menu

You can create a macro by drawing a selection rectangle in the workspace and using the item **New macro** from the workspace context menu. All selected blocks will be moved into a new macro block that will replace the selected blocks in the workspace. All external connecting lines will be retained.

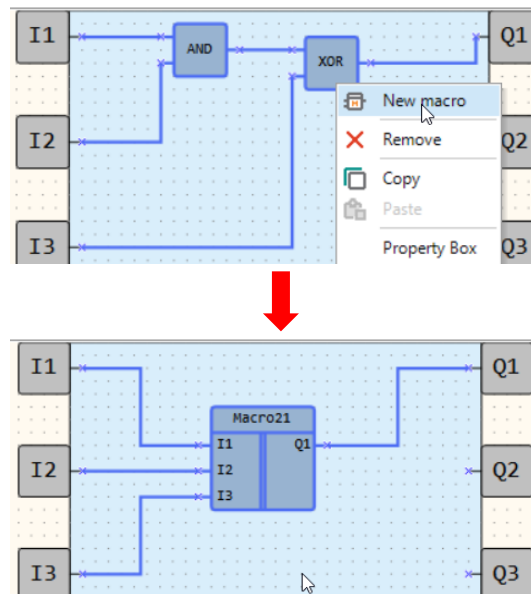

Fig. 6.88

There are some specific aspects of creating macros using context menu:

- The number of inputs and outputs of the macro is equal to the number of connected input and output connections in the selected area. In case the elements without connections are selected, the macro with one input and one output will be created.
 - If a block of the standard variable is selected, the variable will be copied under the same name into the macro.
- Note:** *Despite the same name, the variables in the macro and in the main program are different, there is no conflict between them.*
- If all blocks of the variable are selected and it has no other references in the program, the variable will be moved into the macro.
 - If the selected variable is used (has blocks or other references) outside the selected area, it will be copied under the same name into the macro and the original will remain in the workspace.
 - If only one block of the input or output variable is selected, the variable will be copied under the same name into the macro and the original will remain in the workspace.
 - When the macro is created using the context menu, the following elements will not be included in it:

Library

- device inputs and outputs
 - service variables
 - network variables
 - PID controller
- In case the above mentioned blocks are selected, they will remain in the main workspace and will be connected to the corresponding I/O points of the macro.
 - If any **WriteToFB / ReadFromFB** blocks (sect. 7.7) are assigned to the selected FB, they will be included to the macro, even if they are not selected. If the read/write blocks are selected but not the assigned FB, they will not be included in the macro.

6.3.5 Update macro

If the macro used in the program has been modified, (name, type, number of I/O points, or the parameter **Use in macro** of any block), it will be displayed in red in the program and the user will be prompted to update the macro. A macro is considered to be modified after the changes made in Macro Editor are saved.

To update the macro, use its context menu.

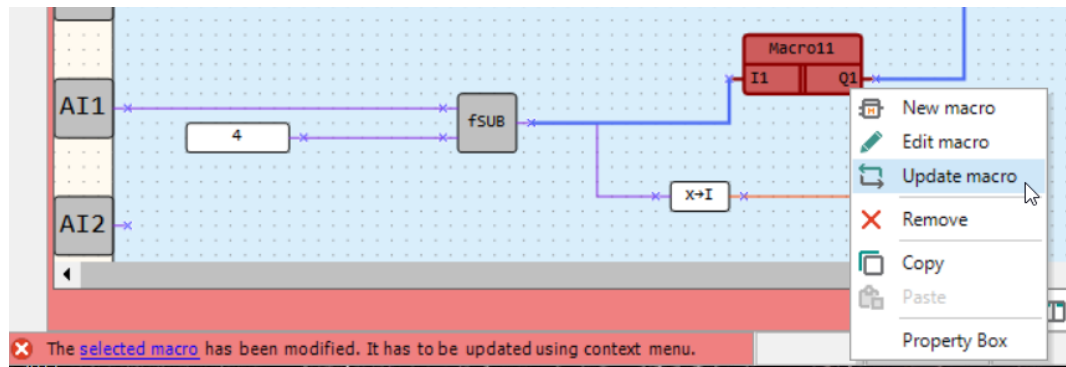

Fig. 6.89

Once the macro has been updated, the next modified macro will be prompted to update.

Update rules:

- If the type or name of the macro I/O points with the attached connection is changed, the connection will be disconnected after the update.
- If I/O points are added to the macro, the existing I/O points will not be disconnected after the update.
- Macro I/O points are identified by name and type. If you change the name or type of an I/O point with an external connection and create a new I/O point with the same name and type, the connection will be automatically linked to the new I/O point after the macro update.

6.3.6 Replace macro

If a macro should be replaced with another one, it can be done manually: delete the macro, add a new macro and restore the connecting lines.

It is more efficient to replace the macro using the context menu command **Replace**. The connecting lines to macro I/O points will be retained if the names and the data types of the old and the new I/O points are the same.

If the name or data type of an I/O point does not match, the connecting line will be cut and should be repaired manually.

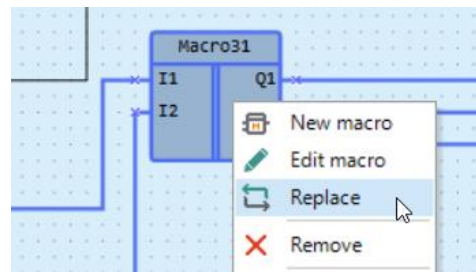



Fig. 6.90

6.3.7 Changing I/O points order

The I/O points of the macro are placed on the sides of the macro in the order in which they were added, from top to bottom.

This order can be changed. This can be useful if you want to place logically related I/O points nearby, or if you want to insert an empty macro into the program and determine the position of its I/O points later, after developing its algorithm.

Proceed as follows:

- Open the macro in the editor, drag and drop the I/O points into the desired order.
- Click on the toolbar icon  **Synchronize I/O order** to synchronize the positions of the I/O points by, and then save the macro.
 - Note:** The synchronization does not work if the macro I/O points are not connected to other program blocks.*
- Go to the main program. The changed macro is highlighted red and it is offered to update it using its context menu (sect. 6.3.5).
- After the update, the order of the macro I/O points in the main program will be the same as in the macro editor. The connecting lines of the macro will be retained.

If the synchronization switch  is not activated, the macro I/O points will be displayed in the main program in the default order. This can be useful if you need to add an I/O point to the macro, but don't want to entangle the existing lines.

6.4 Display elements

Display elements are library blocks of the library that control the information displayed on the device display. They are available in Library Box if the workspace with a display form is active, and can be placed within the display form by drag-and-drop. The following elements are available:

- Text box
- I/O box (INT/REAL)
- I/O box (BOOL)
- Dynamic box
- Combobox

Use Property Box to customize an element.

Common parameters for all elements:

- **Coordinate X** – the position of the first (left) character placeholder of the element from the left form edge (from 0 to 15).
- **Coordinate Y** – the position of the first (left) character placeholder of the element from the upper form edge, depending on the number of the rows in the form.
- There are two ways to determine coordinates: constant (default) or variable. To use the coordinate dependent on a variable, select the coordinate and open the list on the right of the input field.
 - **Constant** – specify the coordinates in Property Box or place the element within the form by drag-and-drop.



Fig. 6.91

- **Variable** – click **Select** to select an INT variable from the list and confirm with **OK**. The display element will move according to the coordinate value controlled by the variable.
- **Length** – the number of the reserved characters. The display element occupies one display row in height, its length can be from 1 to 16 characters.

6.4.1 Text box

Text box is used to display plain text.

Parameters:

Text – text to display. The parameter **Length** specifies the number of the reserved characters.

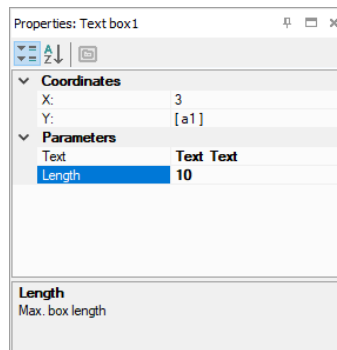

Fig. 6.92

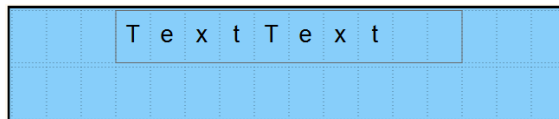

Fig. 6.93

6.4.2 I/O box (INT/REAL)

I/O box (INT/REAL) is used to display a variable of type INT or REAL. The value of the variable can be changed with the device function buttons.

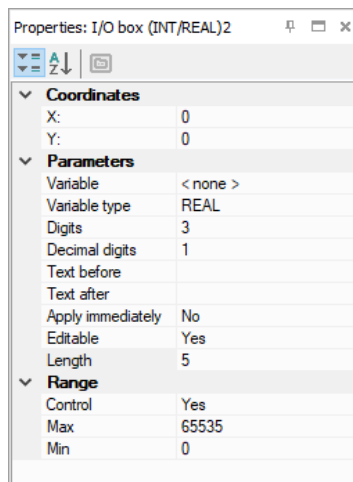



Fig. 6.94

Library

Parameters:

Variable – the reference to a variable. Use the icon  in the input field to select the variable.

Data type – INT or REAL. If the variable has been already selected, its data type will be accepted.

Digits – the total number of the displayed digits

Decimal digits – the number of the characters after the decimal point: 0...6 characters or **Auto** for Auto-precision *.

Text before – the text to the left of the displayed variable

Text after – the text to the right of the displayed variable

Editable – if **Yes**, the displayed value can be changed using the device function buttons

Note: An output variable should be selected. The option has no effect with an input variable.

Length – the total number of the reserved characters including the text before and the text after

Range:

The group of parameters is used to limit the input value. If **Editable = No**, the parameters of this group have no effect.

Limit – if **Yes**, the value entered using the device function buttons is limited by the user parameters **Max** and **Min**, else it is limited only by the available memory area.

Max – the maximum input value

Min – the minimum input value

Example:

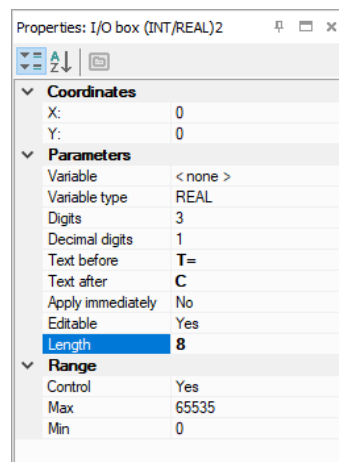

Fig. 6.95

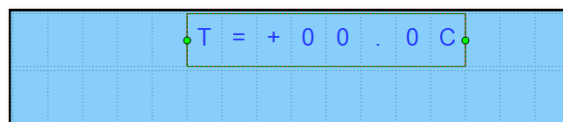

Fig. 6.96

* Auto-precision

The option enables to display a REAL variable most precisely for the set number of reserved characters (parameter **Digits**). To use the option, select in the workspace an I/O-Box display element with associated variable of REAL type and select **Auto** for the parameter **Decimal digits** in the Property Box.

Library

Example:

To display the variable VAR1, 4 digits with Auto-precision are reserved. The value 1.546745 will be displayed rounded as 1.547. If the value will be changed to 110.478696, it will be displayed as 110.5.

6.4.3 I/O box (BOOL)

I/O box (BOOL) is used to display a variable of BOOL type. The value of the variable can be changed with the device function buttons.

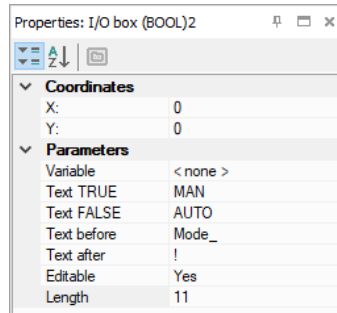



Fig. 6.97

Parameters:

Variable – the reference to a variable. Use the icon  in the input field to select the variable.

Text TRUE – the text displayed if the variable is **True**

Text FALSE – the text displayed if the variable is **False**

Text before – the text to the left of the displayed variable

Text after – the text to the right of the displayed variable

Editable – if **Yes**, the displayed value can be changed using the device function buttons

Note: An output variable should be selected. The option has no effect with an input variable.

Length – the total number of the reserved characters including the text before and the text after

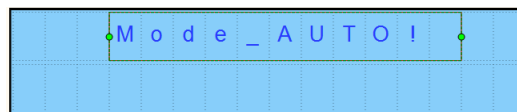

Fig. 6.98

6.4.4 Dynamic box

Dynamic box is an output field. It is used to display one of the text rows from a list depending on a row **ID**. The row **ID** is saved in a referenced variable of INT type.

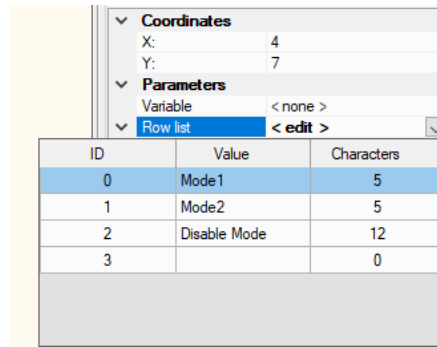

Fig. 6.99

Parameters:

Variable – the reference to a program variable. Use the icon in the input field to select the variable.

Row list – the list with text rows. The **Text** from the row is displayed if the value of the referenced variable is equal to the row ID. The column **Characters** shows the number of characters in the text. An exclamation mark is displayed near the number if the value of the parameter **Length** is exceeded.

Length – the number of the reserved characters

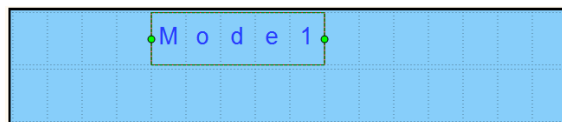

Fig. 6.100

6.4.5 ComboBox

ComboBox is an input / output field. It is used to display one of the text rows from a list depending on a row **ID**. The row **ID** is saved in a referenced variable of INT type. The **ID** can be selected also using the device function buttons.

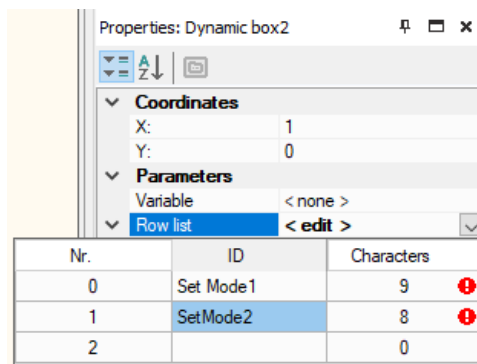

Fig. 6.101

Parameters:

Variable – the reference to a program variable. Use the icon in the input field to select the variable.

Row list – the table with text rows. The **Text** of the selected row is displayed and the row **ID** is saved in the referenced output variable. The column **Characters** shows the number of characters in the text. An exclamation mark is displayed near the number if the value of the parameter **Length** is exceeded.

Length – the number of the reserved characters

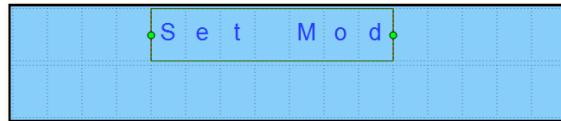

Fig. 6.102

7 Circuit program development

It is recommended to start creating a circuit program with planning. The plan should describe all possible states of the device during operation in form of a mode diagram, a table of I/O states, an electrical or functional diagram, etc.

After all the operation tasks are described, the program can be developed using the standard blocks from the toolbar **Insert** (Table 2.6) and the specific blocks from the project library (sect. 6). The project library presented in Library Box (sect. 2.4) contains the functions (sect. 6.1) and the function blocks (sect. 6.2) available for the target device, as well as the macros added to the project (sect. 6.3).

For details about using of an individual block see sect. 7.1 – 7.8, for other practices of program development see sect. 7.9 – 7.11.

To draw connecting lines, use the left mouse button:

- Click the output pin of the first block. The line is attached to it and follows the mouse cursor.
- To change the line direction, click on the workspace.
- Pull the line up to the input pin of the second block and click on it to finish the line.

The connecting line can be drawn only between block connection pins assigned to the same data type. To connect the connection pins assigned to different data types, use conversion blocks (sect. 7.8).

Click the block to select it. Pull the rectangle around several blocks to select a group.

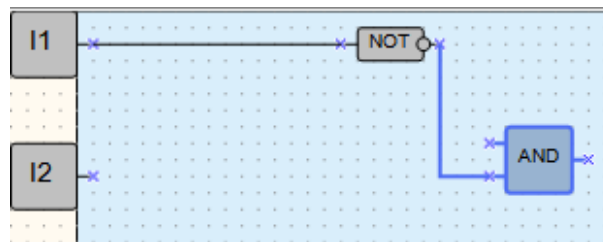

Fig. 7.1

The parameters of the program blocks can be set in Property Box (sect. 2.5).

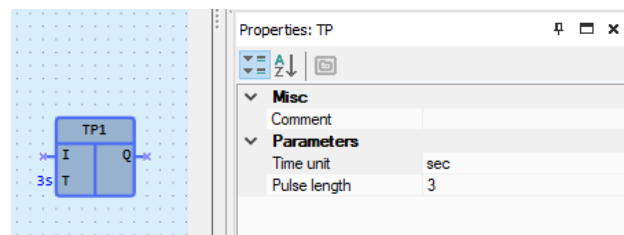

Fig. 7.2

Use element context menu for all manipulation available with the element.

7.1 Using of library blocks

To place a library block in the circuit program, select the desired block in Library Box and move it onto the workspace by drag-and-drop.

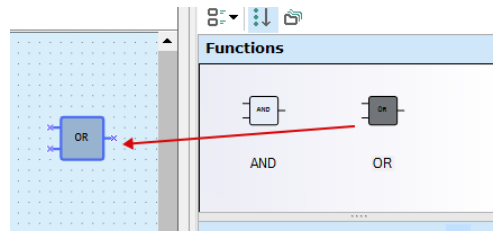

Fig. 7.3

7.2 Using of text field

Text fields are used to explain the program.

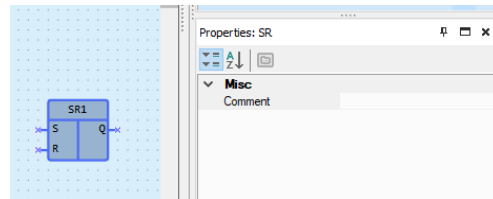

Fig. 7.4

To add a text field to the program, click the icon  in the toolbar **Insert** (Table 2.6), then choose the place for the text field in the workspace and use the left mouse button to draw a rectangle.



Fig. 7.5

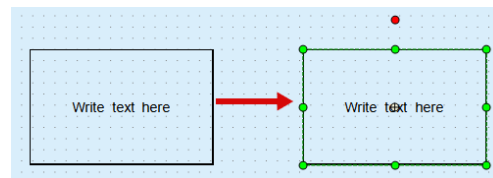

Fig. 7.6

Double-click the text field to write the text.

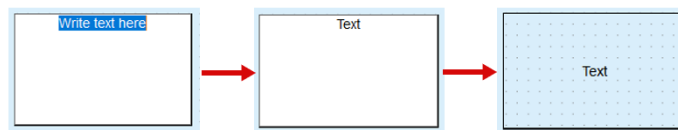

Fig. 7.7

The parameters of the text field can be changed in Property Box.

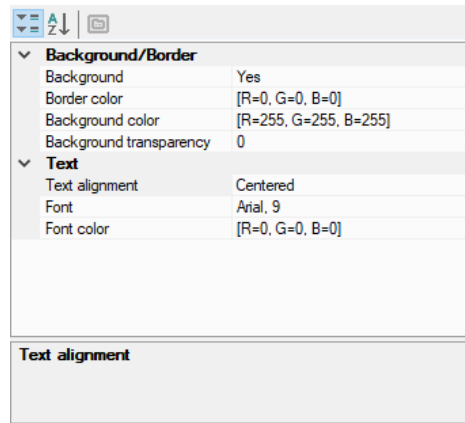

Fig. 7.8

7.3 Using of variables

To add a variable to the program click the corresponding icon in the toolbar **Insert** (Table 2.6), then click the workspace to place the variable block.



Fig. 7.9

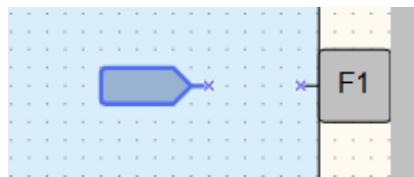



Fig. 7.10

To reference a variable to the block use the icon  in the row **Variable** in Property Box. The variable table opens, but only the appropriate tabs in the table are visible. The selection of the displayed variables is determined by the type of the block.

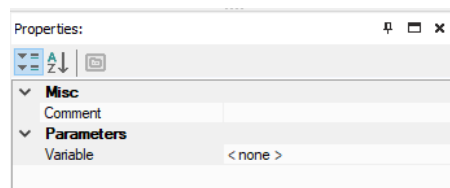

Fig. 7.11

Select a variable or create a new one in the variable table (sect. 5) and confirm with **OK**.

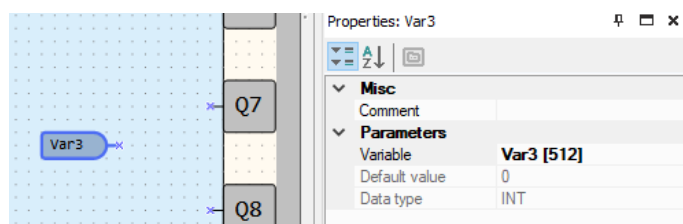

Fig. 7.12

Use network variables to exchange data with other devices connected to the target device over network. For further details about using of network variables, refer to sect. 7.6. If a variable block is highlighted in red, it means that the creation is incorrect or not completed.

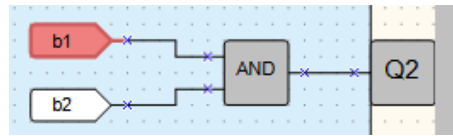



Fig. 7.13

The information about the error is displayed in the status bar.

It is recommended to start programming with the creation of variables in the variable table.

If a variable is used more than once in a project, all references can be followed with the item **Show references** in the variable block context menu. The function is also available in simulation or online debugging modes.

7.4 Using of constants

To add a fixed value to the program click the icon  in the toolbar **Insert** (Table 2.6), then click the workspace to place the constant block.

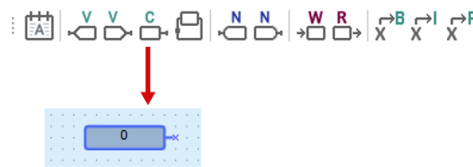



Fig. 7.14

Select the data type using the icon  in the row **Data type** and enter the value in the row **Constant value** in Property Box.

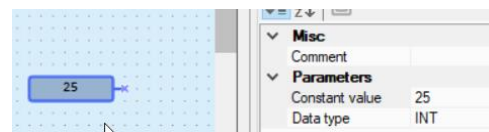

Fig. 7.15

The value of the constant is not subject to change throughout the program execution.

It can be changed after double clicking on the constant block, in Property Box or by selecting **Change value** in the block context menu.

Table 7.1 Data types valid values

Data type	Valid value
BOOL	0 / 1
INT	0...4,294,967,295
REAL	-3.402823e+38...3.402823e+38

7.5 Using of delay lines

A delay line is used to transfer the value from the block output to the block input, delayed for one cycle. The output and input may belong to different blocks.

Click the icon  in the toolbar **Insert** (Table 2.6) and draw a line from the output to the input of a function or a function block. The delay line is displayed as a red dashed line with an arrow.

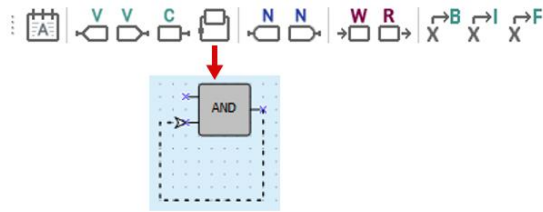

Fig. 7.16

Example:

A constant value 1 is transferred to the input I1 of the addition block ADD (Integer). A value from the block output (Q) calculated in the previous cycle is transferred to the input I1 over delay line.

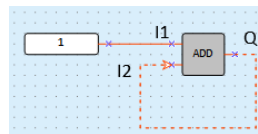

Fig. 7.17

Table 7.2 Cycle signal values

Cycle	1	2	3	4	5	6	7	8	9	10
I2	0	0	1	1	2	2	3	3	4	4
Q	1	1	2	2	3	3	4	4	5	5

7.6 Network data exchange

The network input and output variables are special type of variables for data exchange between devices connected to a common network.

The variables can be read via the network are called Network output variables ($\overset{N}{\square}$).

The variables can be written via the network are called Network input variables (\square^N).

To add a network variable to the program proceed as follows:

- Click the icon $\overset{N}{\square}$ or \square^N in the toolbar **Insert** (Table 2.6).
- Click the workspace to insert the variable.
- Click the icon \dots in the row **Variable** in Property Box to select a variable for the block.

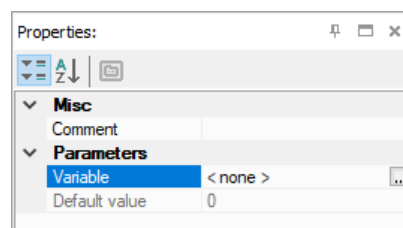

Fig. 7.18

- Select a variable or create a new one in the opened variable table and confirm with **OK**. The selected variable is assigned to the variable block.

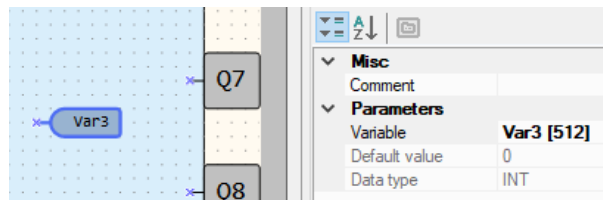

Fig. 7.19

- Connect the network variable output block to the desired block in the workspace.

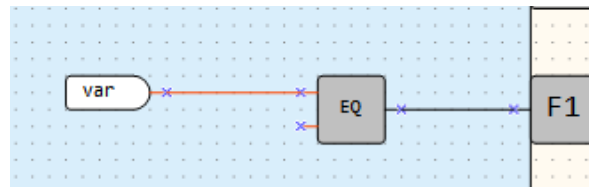

Fig. 7.20

If the network output variable block is used for requesting a slave, it receives an additional parameter **Write at the end of cycle**. If the parameter is set to **Yes**, the new value of the variable is assigned only at the end of the cycle, when all input variables are already read out.

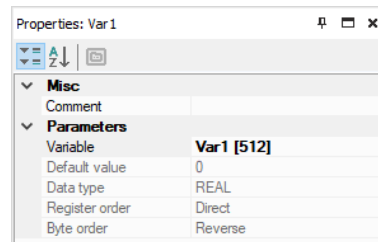

Fig. 7.21

Note: A variable cannot be coupled with a block if there is no communication interfaces in the device settings.

7.7 Read / write in FB

The block **WriteToFB** is used to change an FB parameter during the process.

Example:

The value of the parameter **ON-duration** of the FB **BLINK1** should be 2 or 10 depending on the value at the input **I5**.

To add the block **WriteToFB** to the program, click the icon  in the toolbar **Insert** (Table 2.6), then click the desired place in the workspace.

Go to Property Box, select the FB **BLINK1** in the row **Function block** and the parameter of the FB in the row **Parameter in FB** (Fig. 7.22).

Circuit program development

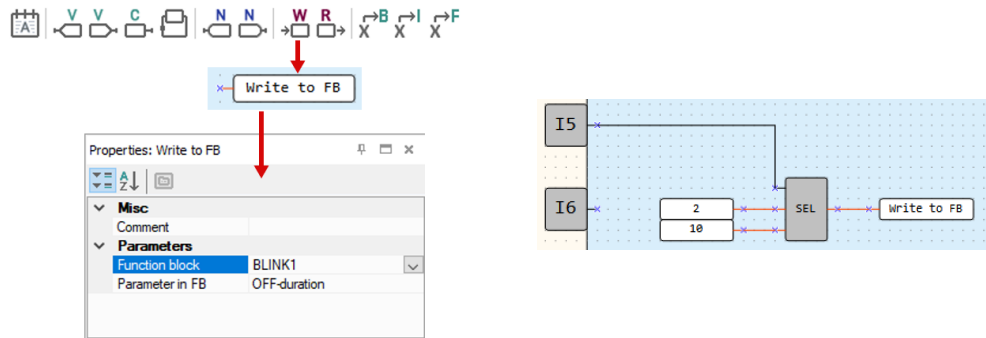

Fig. 7.22

The block **ReadFromFB** is used to read the current value of an FB parameter and use it in the program. The using is the same as of the **WriteToFB** block.

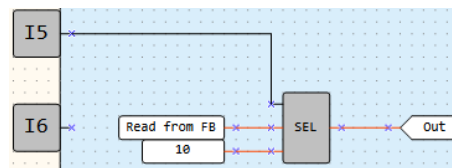

Fig. 7.23

7.8 Conversion blocks



Fig. 7.24

Conversion blocks are universal blocks used to convert an input value of any type into a value of a certain type. There are three blocks available in the **Insert** toolbar (Table 2.6):

Table 7.3 Conversion blocks

Conversion to BOOL	Conversion of INT or REAL to BOOL (If the input value > 0, the output = 1 / True)
Conversion to INT	Conversion of BOOL or REAL to INT (REAL is rounded down to INT)
Conversion to REAL	Conversion of BOOL or INT to REAL

To add the conversion block to the program click one of the three icons in the toolbar **Insert** (Table 2.6), then click the desired place in the workspace.

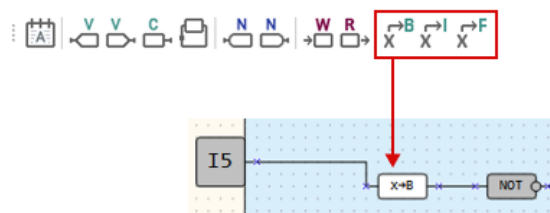

Fig. 7.25

7.9 Arrange elements

The sequence numbers of the function blocks can be automatically re-assigned by clicking the button **Arrange elements** in the toolbar **Service** (Table 2.6). The blocks of the same type are numbered sequentially from top to bottom and from left to right.

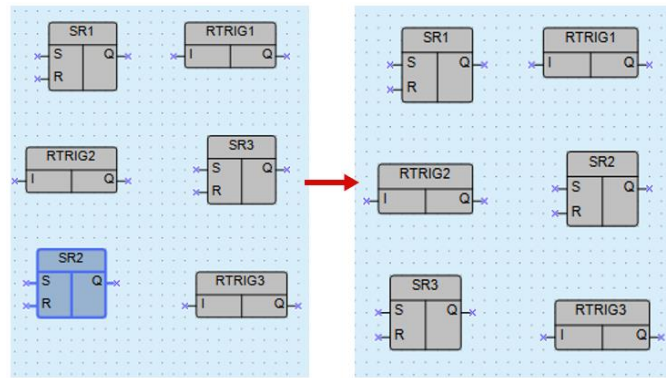

Fig. 7.26

7.10 Execution sequence

Calculation of the values for outputs and delay lines is performed in a certain order. To see this order click the arrow near the icon in the toolbar **Service** and select the **Delay lines** or **Outputs** (Table 2.6).

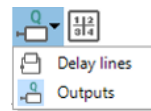

Fig. 7.27

To change the order, double-click an output or a delay line and enter the desired number.

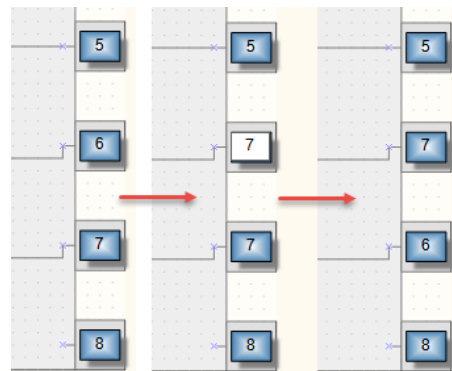

Fig. 7.28

Click the icon to deactivate the edit mode.

7.11 Simulation

Use the simulation to proof the correctness of the created program. Only the offline simulation is currently possible. The simulation enables to analyze the values of all signals within the circuit program. Change the values at the digital and analog inputs as well as of variables and constants and check the values at the outputs.

7.11.1 Operation

To start / stop the simulation mode, click the icon **Simulation mode** in the toolbar **Service** (Table 2.6). A new toolbar **Simulation** is displayed with the following controls:

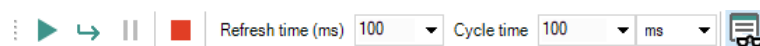

Fig. 7.29

Circuit program development

Table 7.4 Simulation toolbar

	Start	Start the permanent simulation
	Single cycle	Step-by-step simulation. Click the icon to execute one program cycle.
	Pause	Interrupt the simulation. Click the icon once more to continue the simulation.
	Stop	Stop simulation
Refresh time (ms) 100	Refresh time	Simulation refresh time in milliseconds
Cycle time 100	Cycle time	Cycle time
ms	Time unit	Cycle time units: milliseconds, seconds, minutes, hours
	Watch Window	Open / close the window to watch the variables values at each program step (sect. 7.11.2)

An additional toolbar **Calendar** is displayed in simulation mode if there are FBs of type CLOCK or CLOCKW in the project (available only for devices with real-time clock).



Fig. 7.30 Calendar toolbar

The parameter **Refresh time (ms)** specifies the simulation cycle.

The parameter **Cycle time** specifies the program execution cycle during the simulation.

Note: The parameters **Cycle time** in device (sect. 3.2) and in ALP simulation mode are different in spite of the same name.

Both parameters can be adjusted for faster or slower simulation of FBs CLOCK, CLOCKW and BLINK.

The values of inputs, outputs and variables can be set by clicking on the block in the workspace and entering a new value in the open dialog. The value of a network variable can be set as well.

The digital inputs and outputs change their value and the color after each click.

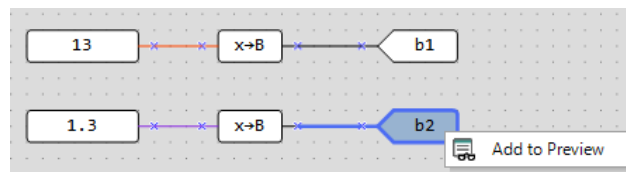

Fig. 7.31

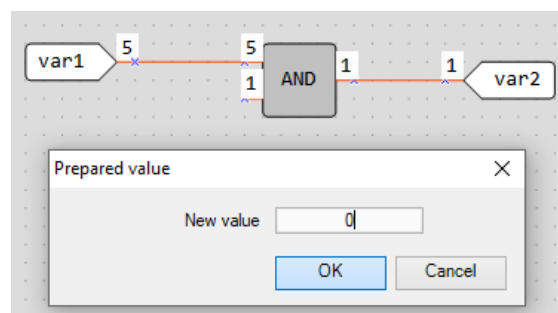

Fig. 7.32

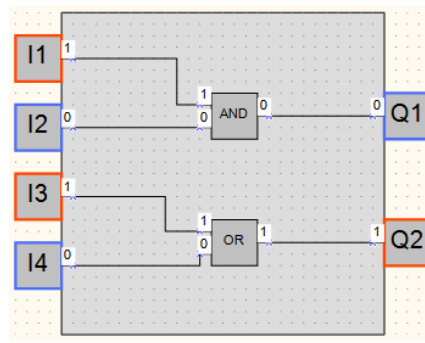

Fig. 7.33

If you want to make changes to the program, stop the simulation.

Notes:

- *Macros are excluded from simulation. Simulation for macros should be performed separately in the workspace of the macro.*
- *Simulation cannot be performed for*
 - o *blocks without connections with device outputs or a network variables*
 - o *incorrectly coupled variables*
 - o *retain variables*

7.11.2 Watch Window

Click the icon on the simulation toolbar to track the input, output or variable values at every program step.

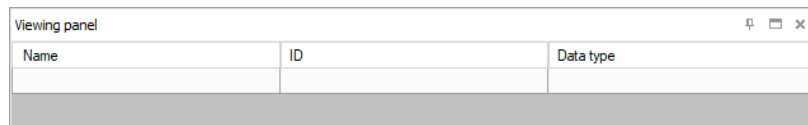

Fig. 7.34 Watch Window

To add a variable, input or output to the Watch Window, click in the empty field in the **Name** column and then click the icon appeared to the left. The context menu of these blocks can also be used.

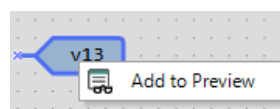

Fig. 7.35 Variable context menu in simulation

The values of the variables, inputs and outputs can be set in the **Value** column during simulation.

7.12 Online debugging

To start the online debugging, click the icon in the toolbar.

In this mode the current values of all program variables, including functions, function blocks, macros, inputs and outputs, are read out from the connected device and displayed in the workspace. This way you can check the logic of the device program.



Fig. 7.36

Circuit program development

The online debugging is possible only if:

- the device is connected to the PC
- the program in the device and the program opened in ALP is the same
- the version of the device firmware is compatible with the current version of ALP

The online debugging is only available for the main program workspace, not within macros.

It is not possible to make changes in the project during online debugging. Exit online debugging by clicking the  icon once more if you want to modify the project.

Note: If communication with the device is lost, online debugging is terminated after 10 seconds and the device is switched to operating mode. If the connection is restored within 10 seconds, online debugging continues, but the entered values are reset.

Manual value entry

It is possible to change the variable input value during online debugging by clicking on the displayed value (Fig. 7.34). The new value should be entered in the field **New value** in the opened window **Prepared value**. There are two options to change the value: one-off or permanent change.

The one-off change enables to change the variable input value for one program cycle. In the subsequent cycles, the signal from one of the device inputs or the output of another program component connected to this input is used. The option is useful for single pulse simulation.

When using the option **Permanent change**, the entered value is applied to the input until the option is unchecked or the online debugging is stopped. The option is useful for simulation of time-constant signals.

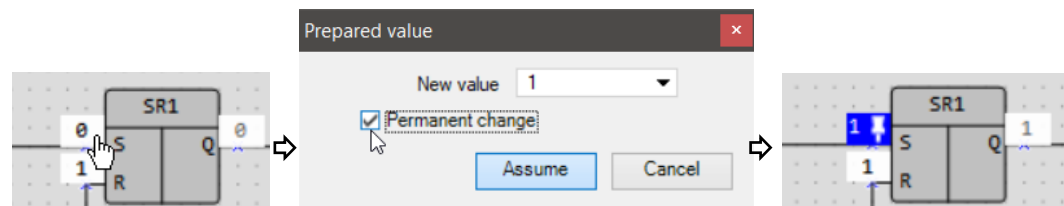

Fig. 7.37

Note: Data exchange in online debugging mode is limited, and the limit depends on the device model. A sign that the restriction is triggered are empty value cells in the diagram during online debugging. In this case you should increase the scale of the workspace (see 2.3) so that fewer values fall into the visible area. The entered values that do not fall into the visible area remain saved, but do not occupy the memory area allocated for the data exchange.

Display programming

8 Display programming

To determine the displayed information, use the tab **Display Manager** in the upper left corner of the window. Display Manager (sect. 2.6) is only for target devices with display available.

The display can be programmed using one or more display forms with “jumps” from one to another so that the displayed information can be changed by program events (change of variable) or by operator (button event).

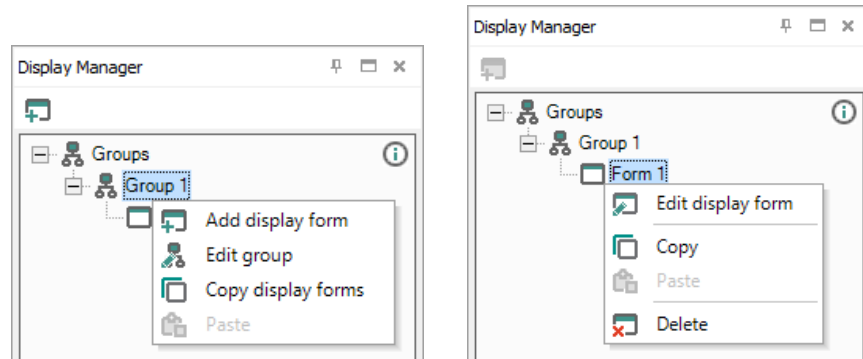

Fig. 8.1

To open the selected form in Display Editor (sect. 8.1), use the command **Edit display form** in the form context menu or double-click the form in the tree (Fig. 8.1).

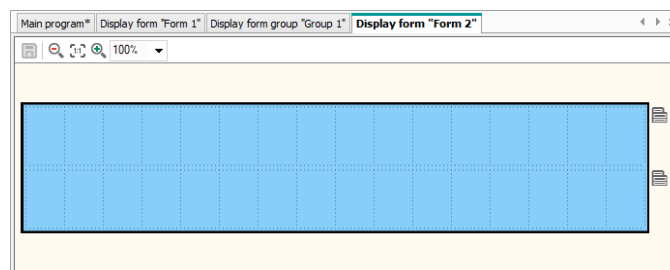

Fig. 8.2 Display Editor

To open a graphical structure of display forms in Structure Editor (sect. 2.6, 8.2), use the command **Edit group** in the group context menu (Fig. 8.1).

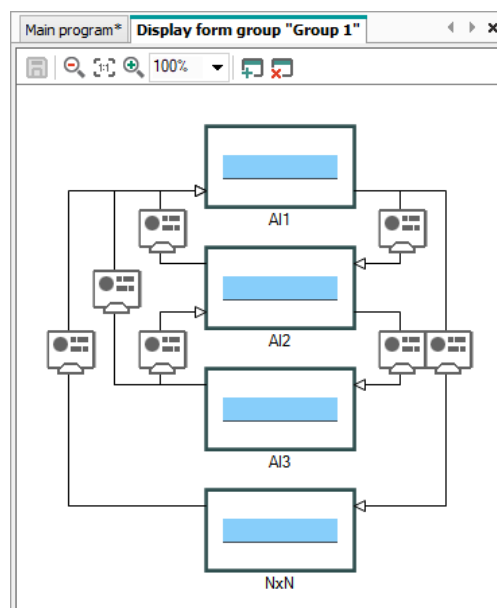



Fig. 8.3 Structure Editor

Display programming

8.1 Display Editor

A form may consist of several rows, at least two. The operator can switch between them using the device function buttons. A display form is shown in the workspace with icons  on the right edge, which are used to change the number of the displayed rows. The rows displayed first are outlined.

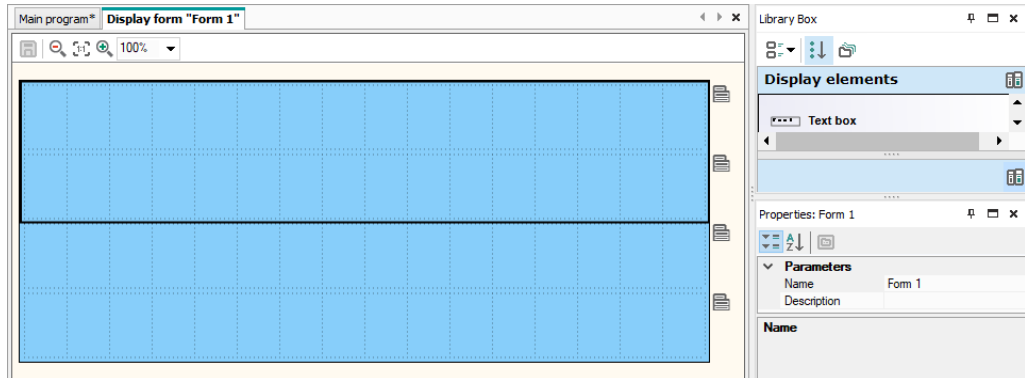



Fig. 8.4

Put the display elements from Library Box by drag-and-drop onto the form. For more information about display elements refer to sect. 6.4.

8.2 Graphical structure

To open a graphical structure of display forms in Structure Editor (sect. 2.6), use the command **Edit group** in the group context menu (Fig. 8.1).

By default, the graphical structure consists of one form. To add a display form to a group:

- In Display Manager, use the group context menu or the toolbar icon  (active if the group is selected) (Fig. 8.1).
- In Structure Editor, use the toolbar icon  (Fig. 8.2).

To remove the form:

- In Display Manager, use the item **Delete** in the form context menu (Fig. 8.1).
- In Structure Editor, use the toolbar icon  or the form context menu.

To change the position of a display form within a group in Display Manager, hold the Shift key while you drag-and-drop the form.

If the display structure consists of more than one form, “jumps” should be defined to enable the navigation between forms (sect. 8.3, Fig 8.2).

To use copy / paste operations for display forms see sect. 8.4.

8.3 Form properties / Jumps

Select a form in the structure to see its properties:

- Name
- Description
- Jump parameters

Each new display form has a default name that can be changed here. The description is optional.

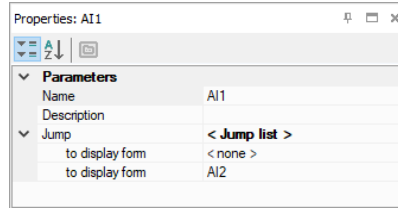

Fig. 8.5

To program the navigation through the display forms using different events, click the icon in the row **to display form**. In the opened dialog **Jump** in the section **to display form**, select the form to which the display should switch if in the **Jump condition** section specified event occurs.

Select the event in the section **Jump condition**, as a device event or change of a variable by value.

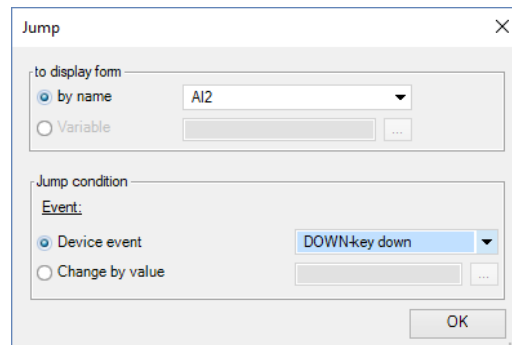

Fig. 8.6

A button event can be selected as **Device event**.

A BOOL variable can be selected for **Change by value** event.

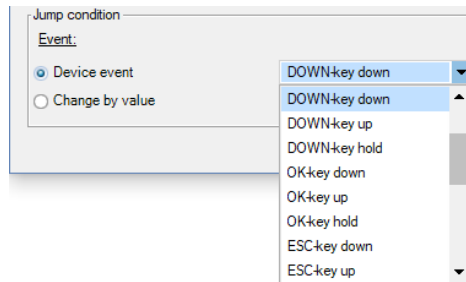

Fig. 8.7 Device events

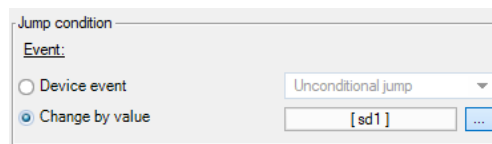

Fig. 8.8 Program events

Confirm with **OK**. The created jump is shown in the structure.

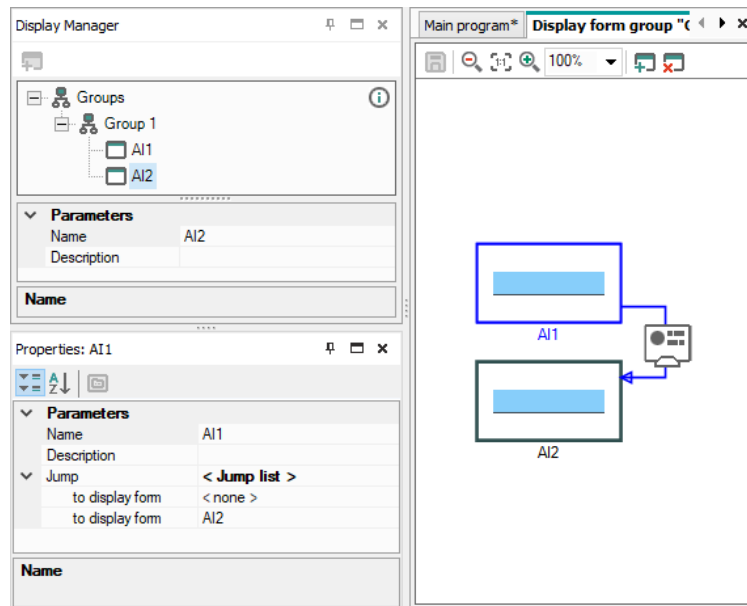

Fig. 8.9 Jump graphical representation

The jump between two forms can occur by several events and the graphical structure can reach a very high complexity.

8.4 Copy / paste display form

A display form or a group of forms can be copied and pasted into the same or another project. To copy a display form or a group of forms, use the item **Copy** in the form context menu and **Copy group** in the group context menu, as well as the shortcut **Ctrl + C**. The keys **Ctrl** and **Shift** can also be used to select several forms.

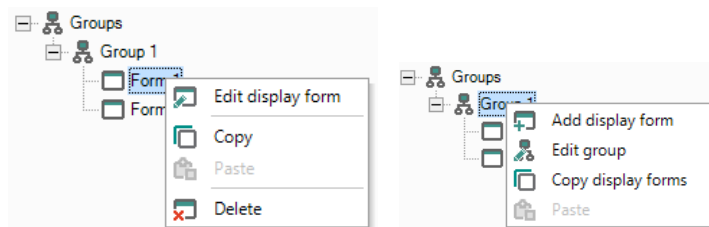

Fig. 8.10

Use the item **Paste** in the form or group context menu or the shortcut **Ctrl + V** to insert the form into the group. The variables associated with the form are copied with, according to the rules described in sect. 5.6 "Copy / paste variables". Jumps between the selected forms are copied with. If only one of the forms connected by the jump is selected, the jump will be deleted during the insertion.

9 Keyboard shortcuts

Shortcut	Description	Use
Ctrl + N	New project	Menu / File
Ctrl + O	Open project	Menu / File
Ctrl + Alt + S	Save project as...	Menu / File
Ctrl + S	Save project	Menu / File
Ctrl + P	Print...	Menu / File
Ctrl + Z	Undo	Menu / View
Ctrl + Y	Redo	Menu / View
Ctrl + F7	Transfer application to device	Menu / Device
F1	Help	Menu / Help
Ctrl + C	Copy	Work with elements
Ctrl + V	Paste	Work with elements
DEL	Delete	Work with elements
Ctrl + →	Increase the element width	Resize element
Ctrl + ←	Decrease the element width	Resize element
Ctrl + ↑	Increase the element height	Resize element
Ctrl + ↓	Decrease the element height	Resize element
Ctrl + wheel up	Zoom+	Resize workspace image
Ctrl + wheel down	Zoom-	Resize workspace image

10 Program examples

Two examples with simple tasks explain the creation of a circuit program in the ALP programming software.

10.1 Task 1: Light switch with automatic switch-off

The task is to switch the light on for a certain time, e.g. for a house entry.

Task definition:

1. The light sensor F1 and the light button SB1 "TIME" are installed in front of the entrance door.
2. If the button SB1 is shortly pressed and the ambient light is insufficient, the light should be switched on for 1 minute – this time should be enough to find a key hole and to open the door.
3. If the button SB1 is pressed for 2 seconds, the light should be switched on for 3 minutes regardless of the ambient light – this mode can be useful for entrance cleaning.
4. Provide the possibility to control the light by commands from external devices or with the switch SA1 "CONST" regardless of the ambient light. This mode can be useful during the reception of guests or for further automation of the apartment as part of the "smart house" program.
5. Provide the possibility to switch on the light only at a certain time.

Device selection:

The control device must have minimum two digital inputs, one digital output and an integrated real-time clock to implement this task. These features can be provided by devices of PR110 series with the letters "RTC" in the designation.

The task implementation with the device PR110-24.8D.4R-RTC:

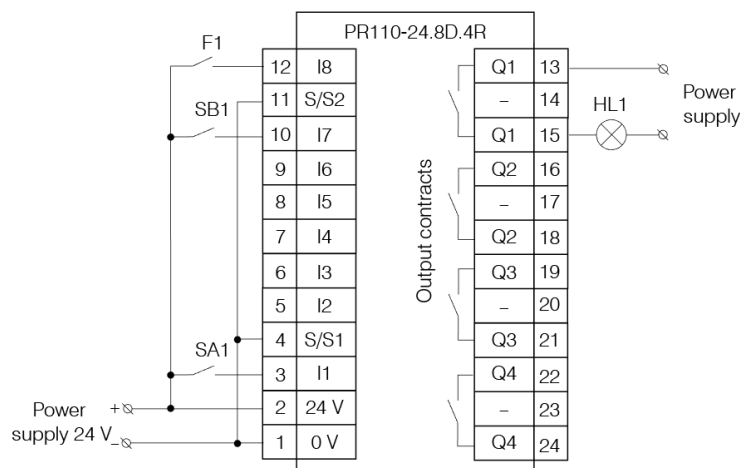

Fig. 10.1

Circuit program

The circuit program can be implemented in the way shown in Fig. 10.2.

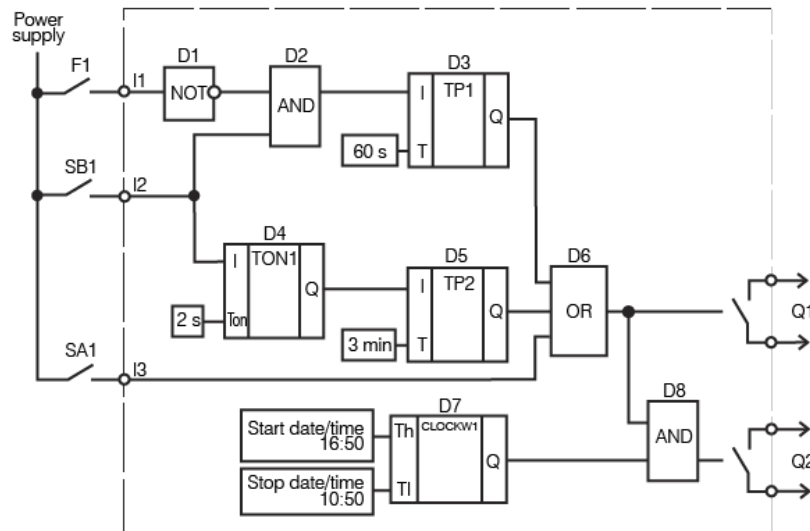

Fig. 10.2

Input I1 – connected to the light sensor F1

Input I2 – connected to the button SB1

Input I3 – connected to the switch SA1

Output Q1 – output to implement the task points 1-4

Output Q2 – output to implement the task point 5

Program description:

1. If the button SB1 is shortly pressed (< 2 s), the logical AND (D2) is enabled. If the ambient light is insufficient, the first input of D2 is also **True** and the timer TP “Pulse” (D3) forms a pulse with 1 minute duration. This pulse activates the output Q1 over the logical OR (D6) and the light is switched on for 1 minute.
2. If the button SB1 is pressed for > 2 s, the on-delay timer TON (D4) activates the timer TP “Pulse” (D5), a pulse with the duration of 3 minutes activates the output Q1 over logical OR (D6) and the light is switched on for 3 minutes.
3. If the ambient light is sufficient, the contact of the sensor F1 is closed, the logical AND (D2) is disabled and the timer TP “Pulse” (D3) is blocked.
4. If the switch SA1 “CONST” is closed, the output Q1 is activated over the logical OR (D6) and the light is switched on constantly.
5. If you want to use the light only on certain weekdays at certain times, you can use the output Q2. With the weekly timer CLOCKW (D7) you can set the start and the stop time and the weekdays for lighting.

The circuit program created in ALP is shown in Fig. 10.3.

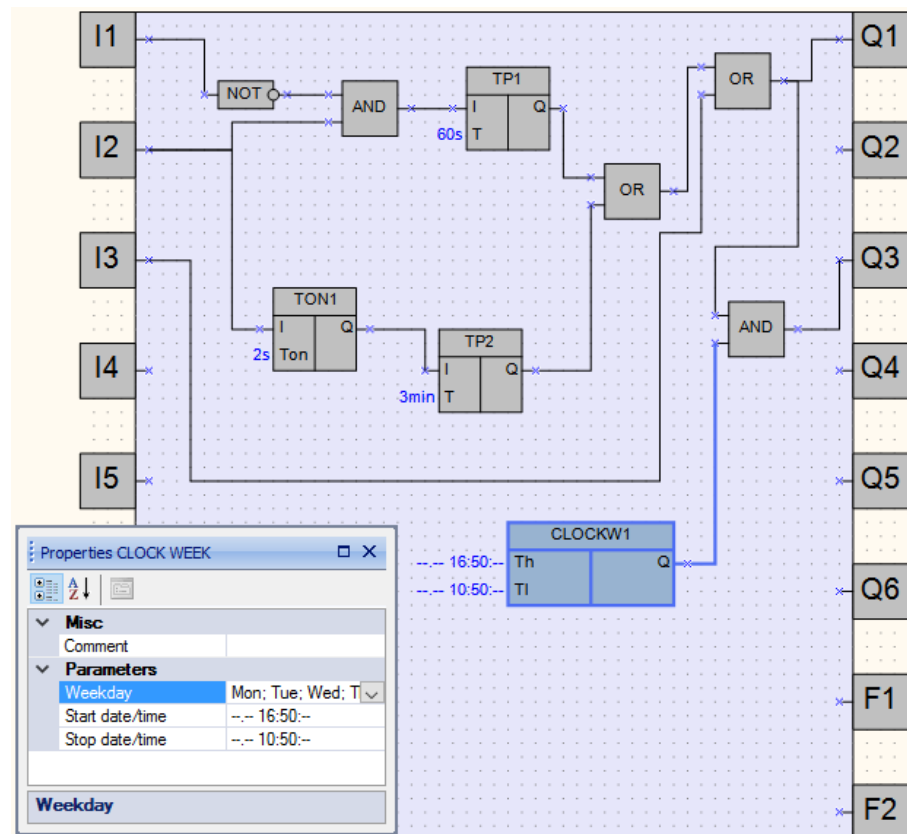

Fig. 10.3

10.2 Task 2: Mixer control

The task is to implement an industrial mixer with simple control functions.

Task definition:

1. Automatic and Manual operation modes are required. The switch SA1 "MODE" is installed to switch between the modes.
2. In Automatic mode the operating cycle can be started with the button SB1 "START" and stopped automatically with the end of the cycle or manually with the button SB2 "STOP". The cycle duration is 5 minutes. During the cycle the motor of the mixer is on for 15 seconds and off for 10 seconds alternately. All settings can be changed in the program.
3. In Manual mode the motor can be started with the button SB1 "START" and stopped with the button SB2 "STOP".
4. When the motor is overloaded (overload switch F1), it should be switched off automatically, an intermittent acoustic warning signal (HA1) with the 3-second interval should be produced and an operating error should be indicated by the signal lamp HL1 "Overload".
5. The acoustic signal can be switched off with the button SB3 "RESET".
6. The button SB4 "CONTROL" is used for the functional test of the lamp HL1 and the acoustic signal HA1.

Device selection:

The control device must have minimum 6 digital inputs and 3 digital outputs to implement this task. These features can be provided by devices of PR110 series.

The task implementation with the device PR110-24.8D.4R:

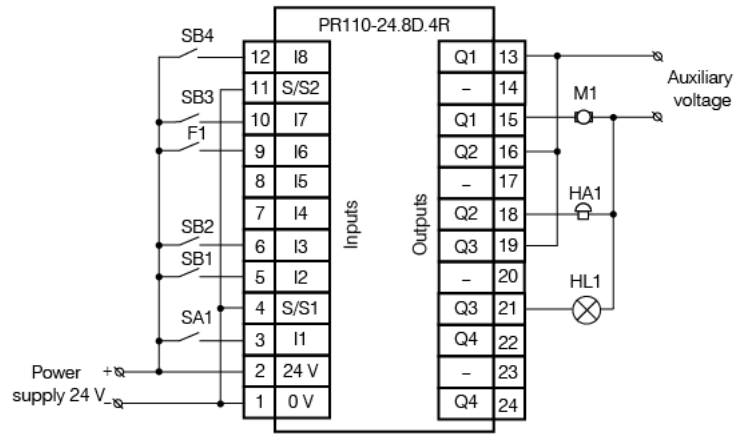

Fig. 10.4

Circuit program

The circuit program can be implemented in the way shown in Fig. 10.5.

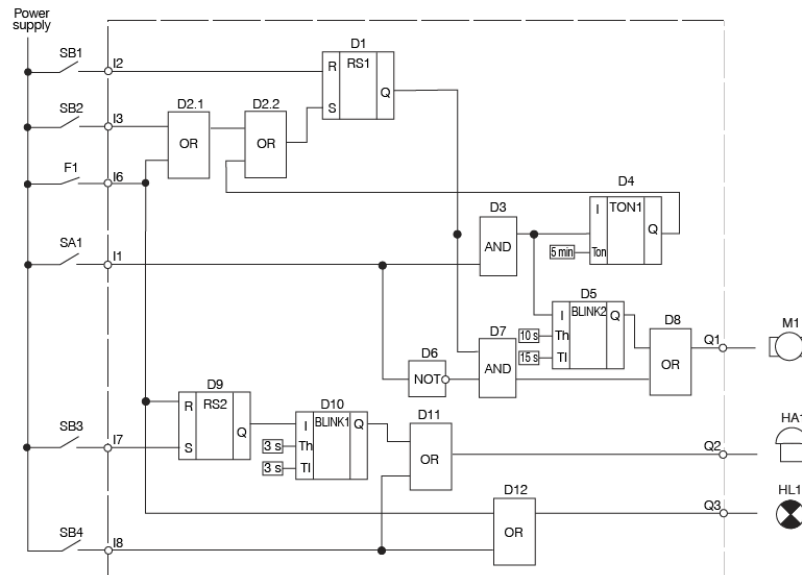

Fig. 10.5

- Input I1 – connected to the switch SA1 “MODE”
- Input I2 – connected to the button SB1 “START”
- Input I3 – connected to the button SB2 “STOP”
- Input I6 – connected to the overload switch F1
- Input I7 – connected to the button SB3 “RESET”
- Input I8 – connected to the button SB4 “TEST”
- Output Q1 – connected to the motor
- Output Q2 – connected to the acoustic signal HA1
- Output Q3 – connected to the signal lamp HL1

Program description:

1. Input I2 (SB1 “START”)

Program examples

If the button SB1 is pressed, the RS trigger D1 becomes **True** as long as there is no reset signal at the input R. Subsequent signal path depends on the state of the switch SA1 “MODE”:

- If SA1 is open (Manual mode), the logical AND (D7) and the logical OR (D8) are enabled and the motor M1 (output Q1) is switched on.
- If SA1 is closed (Automatic mode), the logical AND (D7) is disabled and the start signal can only activate the pulse generator BLINK (D5) to start the operating cycle (15 s on / 10 s off) and the on-delay timer TON (D4) to stop it (in 5 min).

2. Input I3 (SB2 “STOP”)

If the button SB2 is pressed or the switch F1 is activated, the RS trigger D1 is reset over the input R and the output Q1 is disabled.

3. Input I1 (SA1 “MODE”)

- If the switch SA1 is open (Manual mode), the logical AND D3 is disabled and D7 is enabled, the timer D4 and the pulse generator D5 are disabled and the motor M1 can be only started with SB1 and stopped with SB2.
- If the switch SA1 is closed (Automatic mode), the logical AND D3 is enabled and D7 is disabled, thus the motor M1 can be only started by the pulse generator D5 (15 s on / 10 s off cycle) and stopped by the timer D4 in 5 minutes.

4. Input I6 (overload switch F1)

When the motor is overloaded, the F1 contact is closed, the RS trigger D1 is reset and the motor is stopped.

Concurrently the signal lamp HL1 is switched on over the logical OR (D12) and the acoustic signal HA1 is activated over the RS trigger D9. The pulse generator D10 provides an intermittent acoustic signal with the cycle 3 s on / 3 s off.

5. Input I7 (SB3 “RESET”)

The button RESET is used to reset the acoustic signal HA1. If the button SB3 is pressed, the RS trigger D9 is reset and the pulse generator D10 for the acoustic signal HA1 is stopped.

6. Input I8 (SB4 “TEST”)

The button TEST is used to test the acoustic signal HA1 and the signal lamp HL1. If the button SB4 is pressed, the logical ORs D11 and D12 are enabled, the outputs Q2 and Q3 activated, the acoustic signal and the lamp are switched on.

The circuit program is shown in Fig. 10.6.

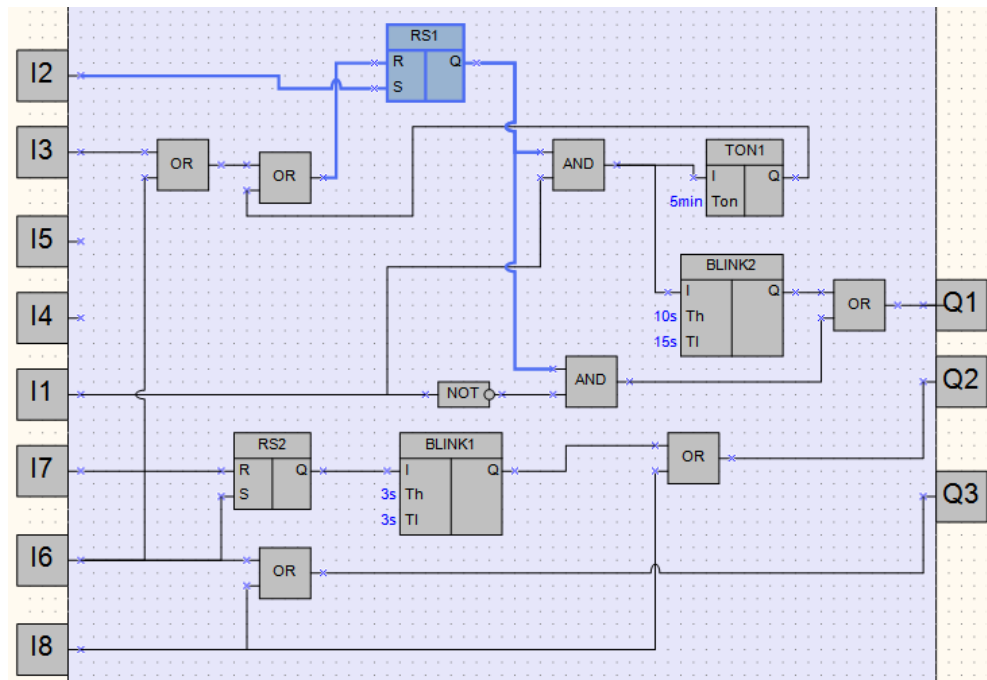

Fig. 10.6

Notes:

1. The remaining two unused inputs and one output can be used for implementation of additional functions. For example, to switch between different time settings for automatic motor operation or to switch other operating parameters of the mixer.
2. The technological cycle of operation can be completely automated by implementation of an incremental counter (CT) to switch off the RS trigger D1.