



AMPLIVAR

TE Internal #: 62305-2

AMPLIVAR, Splices, Splice, Splice, 22 – 15AWG Wire Size, .3 – 1.5 mm² Wire Size, Splice Capacity 3, 600 – 3000CMA Wire Size, Brass, Pigtail Splice

[View on TE.com >](#)

Terminals & Splices > Splices



Splice Product Type: **Splice**

Terminal & Splice Type: **Splice**

Wire Size: **.3 – 1.5 mm²**

Sealable: **No**

Features

Product Type Features

Splice Product Type	Splice
Sealable	No
Splice Type	Pigtail Splice
Serrated	Yes
Splice Barrel Type	Open Barrel
Splice Wire/Cable Type	Magnet Wire
Insulated	No

Configuration Features

Strip Orientation	End Feed
Splice Capacity	3
Number of Serrations	9

Electrical Characteristics

Operating Voltage	250 V
-------------------	-------

Body Features

--	--



Weight per Piece	.181 g
Plating Material	Tin
Splice Material	Brass

Contact Features

Contact Plating Material	Tin
Terminal & Splice Type	Splice

Termination Features

Crimp Width	2.79 mm[.11 in]
-------------	-----------------

Mechanical Attachment

Wire Insulation Support	Without
-------------------------	---------

Dimensions

Wire Size	600 – 3000 CMA
Splice Material Thickness	.41 mm[.016 in]
Splice Overall Length	5.72 mm[.225 in]

Usage Conditions

Insulation Requirement	Uninsulated
Operating Temperature Range	-65 – 150 °C[-85 – 302 °F]

Operation/Application

Heavy Duty	No
------------	----

Industry Standards

Government Qualified Splice	No
-----------------------------	----

Packaging Features

Packaging Quantity	30000
Splice Packaging Method	Strip

Other

Comment	Splice recommended for applications using wire size 28 AWG or smaller.
---------	--

Product Compliance

For compliance documentation, visit the product page on [TE.com](https://www.te.com)>

EU RoHS Directive 2011/65/EU	Compliant
EU ELV Directive 2000/53/EC	Compliant

China RoHS 2 Directive MIIT Order No 32, 2016

No Restricted Materials Above Threshold

EU REACH Regulation (EC) No. 1907/2006

Current ECHA Candidate List: JAN 2021
(211)Candidate List Declared Against: JAN 2021
(211)

Does not contain REACH SVHC

Halogen Content

Low Halogen - Br, Cl, F, I < 900 ppm per
homogenous material. Also BFR/CFR/PVC
Free

Solder Process Capability

Not applicable for solder process capability

Product Compliance Disclaimer

This information is provided based on reasonable inquiry of our suppliers and represents our current actual knowledge based on the information they provided. This information is subject to change. The part numbers that TE has identified as EU RoHS compliant have a maximum concentration of 0.1% by weight in homogenous materials for lead, hexavalent chromium, mercury, PBB, PBDE, DBP, BBP, DEHP, DIBP, and 0.01% for cadmium, or qualify for an exemption to these limits as defined in the Annexes of Directive 2011/65/EU (RoHS2). Finished electrical and electronic equipment products will be CE marked as required by Directive 2011/65/EU. Components may not be CE marked. Additionally, the part numbers that TE has identified as EU ELV compliant have a maximum concentration of 0.1% by weight in homogenous materials for lead, hexavalent chromium, and mercury, and 0.01% for cadmium, or qualify for an exemption to these limits as defined in the Annexes of Directive 2000/53/EC (ELV). Regarding the REACH Regulation, the information TE provides on SVHC in articles for this part number is based on the latest European Chemicals Agency (ECHA) 'Guidance on requirements for substances in articles' posted at this URL: <https://echa.europa.eu/guidance-documents/guidance-on-reach>

Compatible Parts

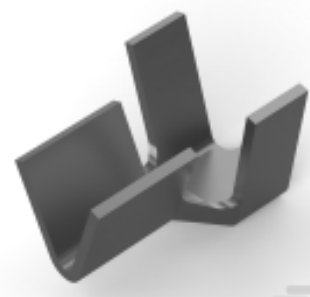
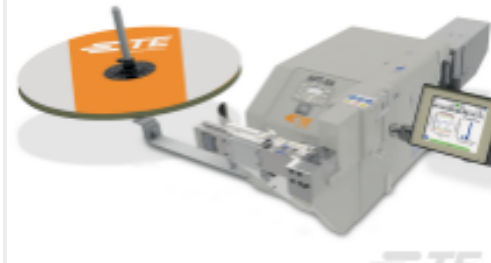
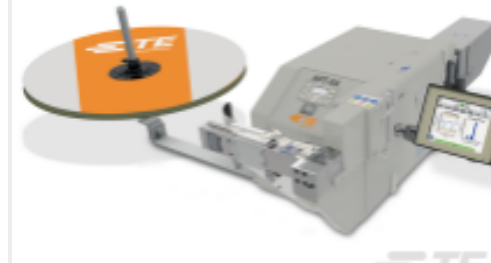
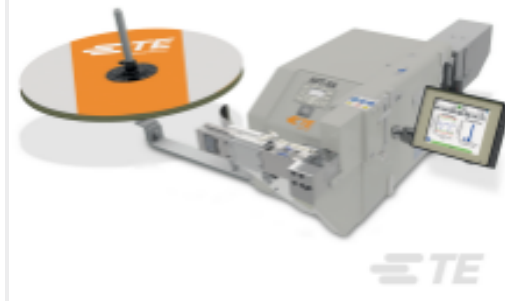
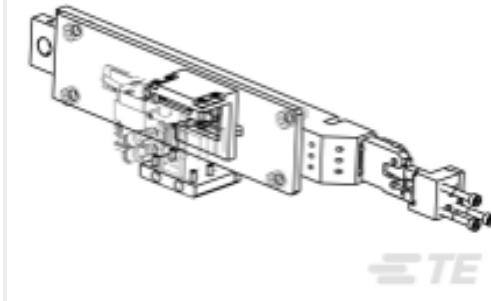
TE Part # 62194-2
MIN AMVAR SPLC 016TPBRTE Part # 737060-2
AMPLIVAR SPL 5 SERR W/INS SUPTE Part # 1-2161800-2
APT-5A TERMINATING MACHINETE Part # 1-2161800-6
APT 5ATE Part # 1-2161900-2
APT-5E TERMINATING MACHINETE Part # 1-2326135-2
APT-5A INFINITE SPLICETE Part # 1-2326143-2
RETROFIT KIT, INFINITE SPLICETE Part # 1-2326145-2
APT-5E INFINITE SPLICE



TE Part # 1742348-1
9 Serr AMPLIVAR Spade



TE Part # 2-2150117-2
OCEAN-2.0-APPLICATOR-E-110F



TE Part # 2150117-2
OCEAN-2.0-APPLICATOR-E-110F



TE Part # 7-2150117-2
OCEAN-2.0-APPLICATOR-E-110F



KIT
TE Part # 7-2150117-7
OCEAN_2.0_SPARE_PART_KIT-110F



TE Part # 1-2161900-6
APT 5E



TE Part # 1-2217600-2
APT-5A HF



TE Part # 1-2217600-6
APT-5A HF



TE Part # 1-2217700-2
APT 5E HF



TE Part # 1-2217700-6
APT 5E HF

Also in the Series | **AMPLIVAR**



Crimp Wire Pins, Tabs & Ferrules(5)



Magnet Wire Terminals(5)



PCB Terminals(1)



Quick Disconnects(42)



Ring Terminals & Spade Terminals(28)



Splices(81)

Customers Also Bought

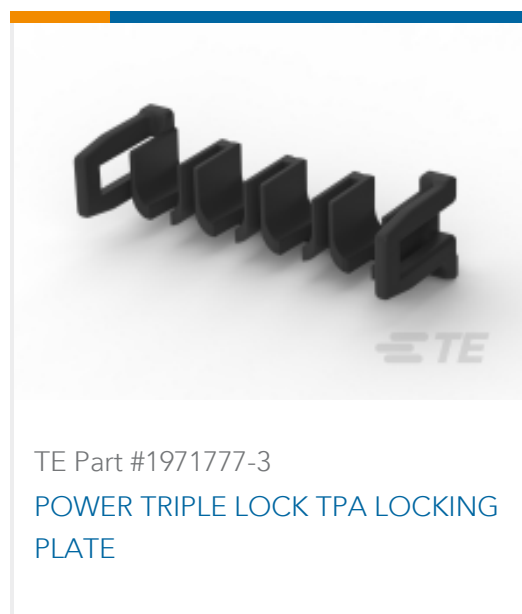

Documents

Product Drawings

[AMVAR SPLC 600-3000 016TPBR](#)

English

CAD Files

[3D PDF](#)

3D

Customer View Model

[ENG_CVM_CVM_62305-2_N.2d_dxf.zip](#)

English

Customer View Model

[ENG_CVM_CVM_62305-2_N.3d_igs.zip](#)

English

Customer View Model

[ENG_CVM_CVM_62305-2_N.3d_stp.zip](#)

English

By downloading the CAD file I accept and agree to the [Terms and Conditions](#) of use.

Datasheets & Catalog Pages



[1654742_HOUSEHOLD_APPLIANCES_RAST5](#)

English

[Magnet Wire Terminals & Splices](#)

English

[Product Specifications](#)

[Application Specification](#)

English

[Product Environmental Compliance](#)

[TE Material Declaration](#)

English