

MDR-170-2 ✓ ACTIVE

CII | CII MDR Series

TE Internal #: 1-1393139-9

CII MDR Series, Power Relays, Rotary, Non-Latching, .04VA Coil

Power Rating AC, 440VAC Coil Voltage Rating

[View on TE.com >](#)



Relays, Contactors & Switches > Relays > Power Relays



Power Relay Type: **Rotary**

Coil Magnetic System: **Non-Latching**

Coil Power Rating AC: **.04 VA**

Coil Voltage Rating: **440 VAC**

Contact Arrangement: **16 Form C, 16PDT, 16 C/O**

Features

Product Type Features

Power Relay Type	Rotary
------------------	--------

Electrical Characteristics

Coil Power Rating	17 W
Insulation Initial Dielectric Between Contacts & Coil	1880 V
Actuating System	AC
Input Voltage	440 VAC
Coil Current	.16 A
Coil Magnetic System	Non-Latching
Coil Power Rating AC	.04 VA
Coil Voltage Rating	440 VAC
Contact Voltage Rating	115 VAC

Contact Features

Contact Arrangement	16 Form C, 16PDT, 16 C/O
Contact Current Rating (Max)	10 A
Contact Material	Silver Cadmium Oxide
Contact Number of Poles	16
Terminal Type	Screw Terminals

Mechanical Attachment

Relay Mounting Type	Screw
---------------------	-------



Dimensions

Base Dimensions	66.68 x 66.68 mm[2.625 x 2.625 in]
Product Height	127 mm[5 in]

Usage Conditions

Operating Temperature Range	0 – 65 °C
-----------------------------	-----------

Packaging Features

Packaging Method	Carton & Box
------------------	--------------

Product Compliance

[For compliance documentation, visit the product page on TE.com>](#)

EU RoHS Directive 2011/65/EU	Not Compliant
EU ELV Directive 2000/53/EC	Not Compliant
China RoHS 2 Directive MIIT Order No 32, 2016	Restricted Materials Above Threshold
EU REACH Regulation (EC) No. 1907/2006	Current ECHA Candidate List: JAN 2021 (211) Candidate List Declared Against: JAN 2021 (211) Does not contain REACH SVHC
Halogen Content	Not Yet Reviewed for halogen content
Solder Process Capability	Not lead free process capable

Product Compliance Disclaimer

This information is provided based on reasonable inquiry of our suppliers and represents our current actual knowledge based on the information they provided. This information is subject to change. The part numbers that TE has identified as EU RoHS compliant have a maximum concentration of 0.1% by weight in homogenous materials for lead, hexavalent chromium, mercury, PBB, PBDE, DBP, BBP, DEHP, DIBP, and 0.01% for cadmium, or qualify for an exemption to these limits as defined in the Annexes of Directive 2011/65/EU (RoHS2). Finished electrical and electronic equipment products will be CE marked as required by Directive 2011/65/EU. Components may not be CE marked. Additionally, the part numbers that TE has identified as EU ELV compliant have a maximum concentration of 0.1% by weight in homogenous materials for lead, hexavalent chromium, and mercury, and 0.01% for cadmium, or qualify for an exemption to these limits as defined in the Annexes of Directive 2000/53/EC (ELV). Regarding the REACH Regulations, TE's information on SVHC in articles for this part number is still based on the European Chemical Agency (ECHA) 'Guidance on requirements for substances in articles' (Version: 2, April 2011), applying the 0.1% weight on weight concentration threshold at the finished product level. TE is aware of the European Court of Justice ruling of September 10th, 2015 also known as O5A (Once An Article Always An Article) stating that, in case of 'complex object', the threshold for a SVHC must be applied to both the product as a whole and simultaneously to each of the articles forming part of its composition. TE has evaluated this ruling based on the new ECHA "Guidance on requirements for substances in articles" (June 2017, version 4.0) and will be updating its statements accordingly.

Compatible Parts



Also in the Series | CII MDR Series

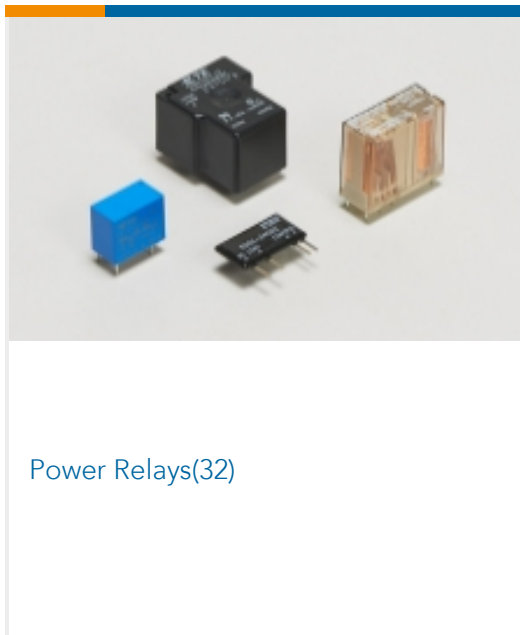

Customers Also Bought

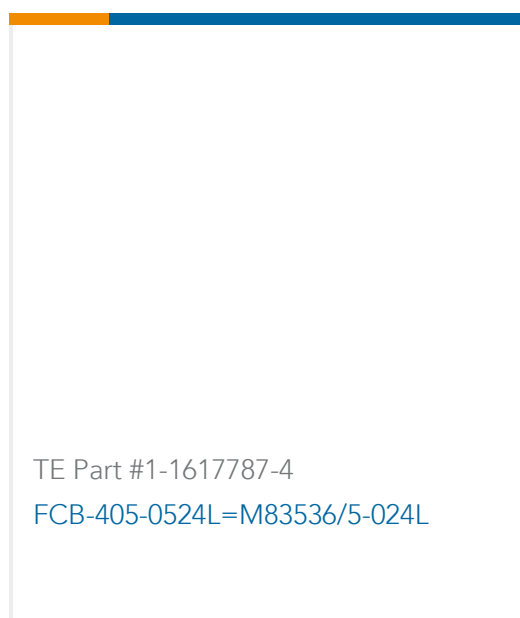
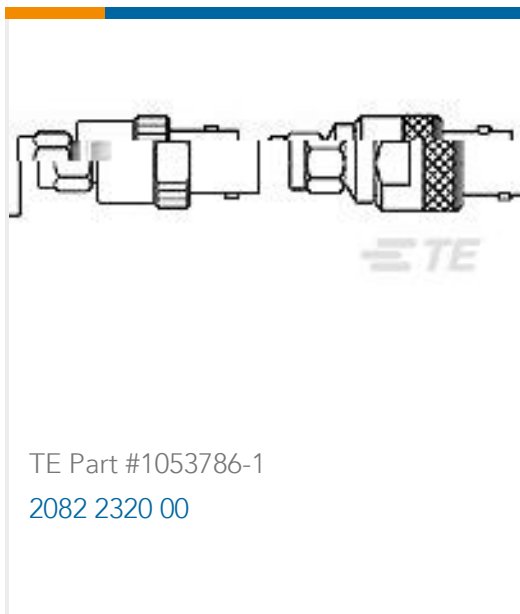



Documents

Product Drawings

[MDR-170-2=MDR](#)

English

Datasheets & Catalog Pages

[5-1773450-5_sec12_MDR](#)

English