

CII

TE Internal #: 1-1437490-1

Time Delay Relays, Knob, 60VDC Time Delay Relay Input Voltage,

Timing Range (Off-Time) 180 – 1800 seconds

[View on TE.com >](#)

Relays, Contactors & Switches > Relays > Time Delay Relays

Type of Control: **Knob**Time Delay Relay Input Voltage: **60 VDC**Timing Range (Off-Time): **180 – 1800 seconds**Time Delay Relay Contact Current Rating: **10A@240VAC A**Mode of Operation: **Off-Delay****Features****Product Type Features**

Enclosure Type	Hermetic Sealed Metallic
Product Type	Relay
Relay Type	Time Delay
Product Category	Electromechanical Relays
Magnetic Blow-Out Device	Without

Configuration Features

Multiple Timing Ranges	Without
------------------------	---------

Electrical Characteristics

Actuating System	DC
Time Delay Relay Input Voltage	60 VDC
Timing Range (Off-Time)	180 – 1800 seconds

Contact Features

Contact Arrangement	2 Form C, DPDT, 2 C/O
Type of Control	Knob
Time Delay Relay Contact Current Rating	10A@240VAC A

Termination Features

Termination Type	Screw Terminals
------------------	-----------------

Mechanical Attachment

Time Delay Relay Mounting Type	Mounting Bracket
--------------------------------	------------------

Dimensions

Dimensions (L x W x H) (Approximate)	114.8 x 65.3 x 71.9 mm[4.523 x 2.572 x 2.832 in]
--------------------------------------	--

Usage Conditions

Operating Temperature Range	-30 – 75 °C
-----------------------------	-------------

Operation/Application

Mode of Operation	Off-Delay
-------------------	-----------

Other

Repeatability (Max)	±10%
---------------------	------

Product Compliance

[For compliance documentation, visit the product page on TE.com>](#)

EU RoHS Directive 2011/65/EU	Not Compliant
EU ELV Directive 2000/53/EC	Not Compliant
China RoHS 2 Directive MIIT Order No 32, 2016	Restricted Materials Above Threshold
EU REACH Regulation (EC) No. 1907/2006	Current ECHA Candidate List: JAN 2021 (211) Candidate List Declared Against: JAN 2021 (211) Does not contain REACH SVHC
Halogen Content	Not Yet Reviewed for halogen content
Solder Process Capability	Not applicable for solder process capability

Product Compliance Disclaimer

This information is provided based on reasonable inquiry of our suppliers and represents our current actual knowledge based on the information they provided. This information is subject to change. The part numbers that TE has identified as EU RoHS compliant have a maximum concentration of 0.1% by weight in homogenous materials for lead, hexavalent chromium, mercury, PBB, PBDE, DBP, BBP, DEHP, DIBP, and 0.01% for cadmium, or qualify for an exemption to these limits as defined in the Annexes of Directive 2011/65/EU (RoHS2). Finished electrical and electronic equipment products will be CE marked as required by Directive 2011/65/EU. Components may not be CE marked. Additionally, the part numbers that TE has identified as EU ELV compliant have a maximum concentration of 0.1% by weight in homogenous materials for lead, hexavalent chromium, and mercury, and 0.01% for cadmium, or qualify for an exemption to these limits as defined in the Annexes of Directive 2000/53/EC (ELV). Regarding the REACH Regulations, TE's information on SVHC in articles for this part number is still based on the European Chemical Agency (ECHA) 'Guidance on requirements for substances in articles' (Version: 2, April 2011), applying the 0.1% weight on weight concentration threshold at the finished product level. TE is aware of the European Court of Justice ruling of September 10th, 2015 also known as O5A (Once An Article Always An Article) stating that, in case of 'complex object', the threshold for a SVHC must be applied to both the product as a whole and simultaneously to each of the articles forming part of its composition. TE has evaluated this ruling based on the new ECHA "Guidance on requirements for substances in articles" (June 2017, version 4.0) and will be updating its statements accordingly.

Compatible Parts



TE Part # 3-1423159-3
7012PJ=RLY,STD,ON,2P,125VDC,1

Customers Also Bought



TE Part #160314-2
PIDG FASTON RECPT QUICK DISCONNECTS



TE Part #1-206138-0
CPC CABLE CLAMPS

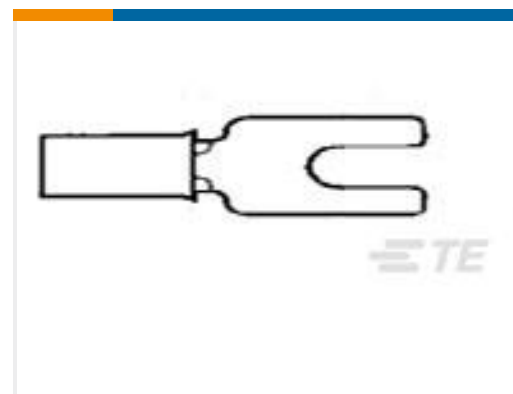

TE Part #165017
PLASTI-GRIP, SPADE 12-10 5MM

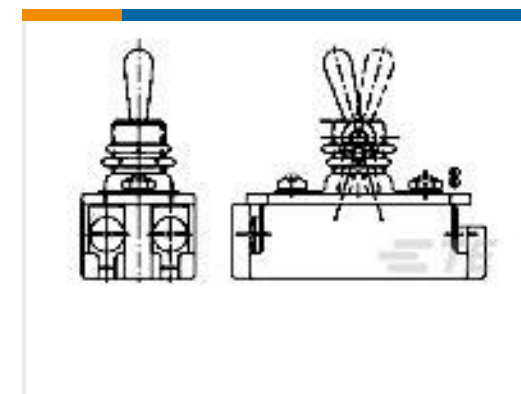

TE Part #1520117-1
8910K94=10 AMP TOGGLE



TE Part #1-1437488-7
7012REA2I=60V DC 20-200 SEC



TE Part #1-963226-1
TIMER, CONNECTOR HOUSING



TE Part #163563-000
B-151-07

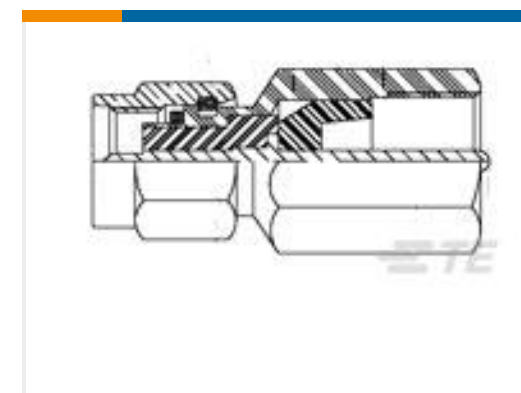

TE Part #1-1337562-0
FME Str Plg-BNCP Adp Nickel Pltd

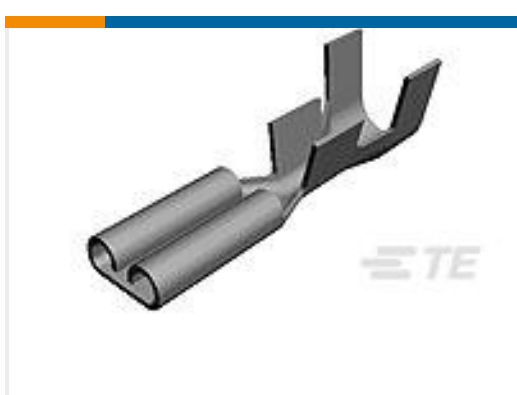

TE Part #140719-2
110 FASTON, REC., 22-18 AWG, TPBR



TE Part #ZPF000000000117246
FICHE F 49PTS T.27 CLAV.N SS CT + M

Documents

Product Drawings

7022RHA2=60V DC 3-30 MIN

English

Datasheets & Catalog Pages

5-1773450-5_sec12_7000

English

