



Dev Board Mini datasheet

Version 1.1

Features

- MediaTek 8167s SoC
 - Quad-core ARM Cortex-A35
 - Imagination PowerVR GE8300 GPU
- Google Edge TPU ML accelerator
 - 4 TOPS peak performance (int8)
 - 2 TOPS per watt
- ARM TrustZone Security
- Wi-Fi 5, Bluetooth 5.0
- 8 GB eMMC, 2 GB LPDDR3
- USB 2.0 Type-C OTG
- HDMI 1.4a (micro)
- MIPI DSI display
- MIPI CSI camera
- 3.5 mm headphone jack
- Digital PDM microphone
- 2.54mm 2-pin mono speaker terminal
- 40-pin GPIO expansion header
- Mendel Linux flashed in factory

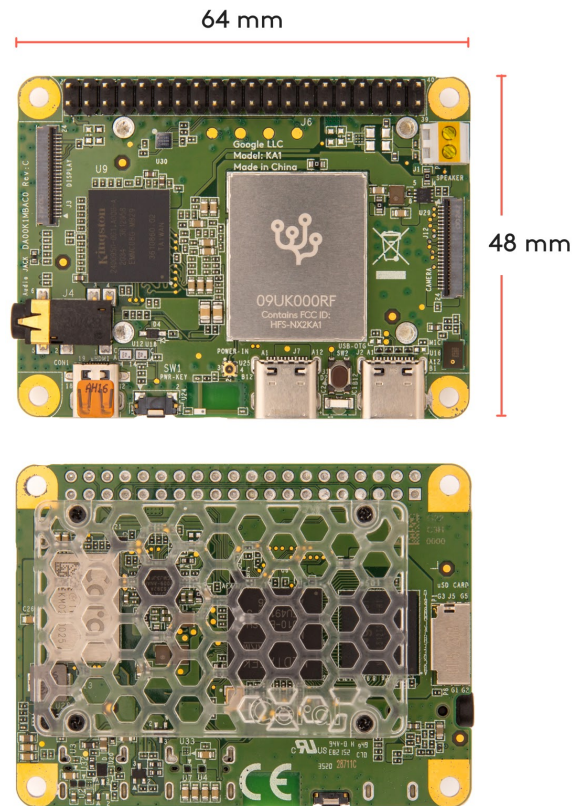

Description

The Coral Dev Board Mini is a single-board computer that enables you to quickly prototype and deploy an embedded system with on-device ML inferencing. This board can also serve as an evaluation device for the [Coral Accelerator Module](#), which allows you to integrate the Edge TPU into your custom PCB hardware as a surface-mounted module.

The Edge TPU is a small ASIC designed by Google that accelerates TensorFlow Lite models in a power efficient manner: each one is capable of performing 4 trillion operations per second (4 TOPS), using 2 watts of power—that's 2 TOPS per watt. For example, one Edge TPU can execute state-of-the-art mobile vision models such as MobileNet v2 at almost 400 frames per second. This on-device ML processing reduces latency, increases data privacy, and removes the need for a constant internet connection.

Ordering information

Part number	Description
G650-03324-01	Coral Dev Board Mini

Table of contents

Features	1
Description	1
Ordering information	1
Table of contents	2
1 System components	3
1.1 Block diagram	5
2 Mechanical dimensions	6
3 Electrical specifications	7
3.1 Recommended operating conditions	7
3.2 Logic threshold levels	7
3.3 Power consumption	7
4 Board peripherals	8
4.1 Buttons	8
4.2 USB-C ports	8
4.3 LED	8
4.4 Mono speaker terminal	9
4.5 Headphone jack	9
4.6 Microphone	9
4.7 Micro HDMI port	9
4.8 MicroSD slot	9
4.9 GPIO header	9
4.10 Camera connector (CSI)	12
4.11 Display connector (DSI)	12
5 Board operation	13
5.1 Power supply	13
5.1.1 Power from the USB ports	13
5.1.2 Power from the GPIO header	13
5.1.3 Power for add-on boards	13
5.2 Shell and serial console	14
6 Document revisions	14

1 System components

Table 1. Dev Board Mini components and features

Feature	Details
Main system-on-chip (MediaTek MT8167s)	
ARM Cortex-A35	Quad-core Cortex-A35 processors: <ul style="list-style-type: none"> • 64-bit Armv8-A architecture • 32 KB L1 Instruction Cache • 32 KB L1 Data Cache • 512 KB unified L2 cache • Frequency up to 1.5 GHz
Graphics Processing Unit (GPU)	Imagination PowerVR GE8300: <ul style="list-style-type: none"> • 150 million triangles/sec • 1.6 gigapixel/sec @ 600MHz • Supports OpenCL 1.2, and Vulkan 1.0 profile • Supports OpenGL ES 1.x, 2.0, 3.0, 3.2 3D
Video Processing Unit (VPU)	<ul style="list-style-type: none"> • 1080p/60fps HEVC main profile decoder • 1080p/60fps main, constraint baseline profile, MPEG4 decoder • 720p/30fps MPEG-1, 2, H.263, H264 decoder
On-chip memory	<ul style="list-style-type: none"> • Boot ROM (96 KB) • On-chip RAM (256 KB + 64 KB)
Audio	<ul style="list-style-type: none"> • Interfaces supports DAI, I2S, TDM, SPDIF • Sample formats support 16-bit, 24-bit, mono, stereo • 4-band IIR compensation filter to enhance loudspeaker response
Display	HDMI 1.4a display output: <ul style="list-style-type: none"> • Supports panel resolution up to 1920x1080 MIPI-DSI display output: <ul style="list-style-type: none"> • 4 data lanes • 24-pin CSI connector • Max bit speed 1 Gb/s
Camera	MIPI-CSI2 camera input: <ul style="list-style-type: none"> • 4 data lanes • 24-pin CSI connector • Supports up to 8 MP camera
Security	<ul style="list-style-type: none"> • Root of trust with on-board cryptochip (A71CH) • ARM TrustZone for chip-to-cloud security
ML accelerator	
Edge TPU coprocessor	<ul style="list-style-type: none"> • High performance ML inferencing for TensorFlow Lite models • 4 trillion operations per second (TOPS) • 2 TOPS per watt • Uses USB 2.0 interface with the MT8167s SoC

Memory and storage	
Random access memory (SDRAM)	<ul style="list-style-type: none">• 2 GB LPDDR3 SDRAM (4-channel, 32-bit bus width)• 1600 MHz maximum DDR clock• Interfaces directly to the built-in DDR controller of the SoC
Flash memory (eMMC)	<ul style="list-style-type: none">• 8 GB NAND eMMC flash memory• 8-bit MMC mode• Conforms to JEDEC version 5.0 and 5.1
Expandable flash (microSD)	<ul style="list-style-type: none">• Meets SD/SDIO 3.0 standard• Supports SD/SDHC/MMC• 32 GiB max card capacity• Runs at 4-bit SDIO mode
Network & wireless	
Wi-Fi	MediaTek MT7658 module: <ul style="list-style-type: none">• Wi-Fi 5 (802.11a/b/g/n/ac 2.4/5GHz)• Supports SDIO3.0 interface for W-LAN
Bluetooth	MediaTek MT7658 module: <ul style="list-style-type: none">• Bluetooth 5.0 (supports Bluetooth low-energy)• Supports UART interface
Peripheral support	
Connectors	<ul style="list-style-type: none">• 40-pin I/O header• USB 2.0 Type-C OTG• USB Type-C power• 2-pin mono speaker terminal• 3.5 mm headphone jack• Micro HDMI• microSD card (half size reader slot)• MIPI DSI display (24-pin flat flex cable)• MIPI CSI camera (24-pin flat flex cable)

1.1 Block diagram

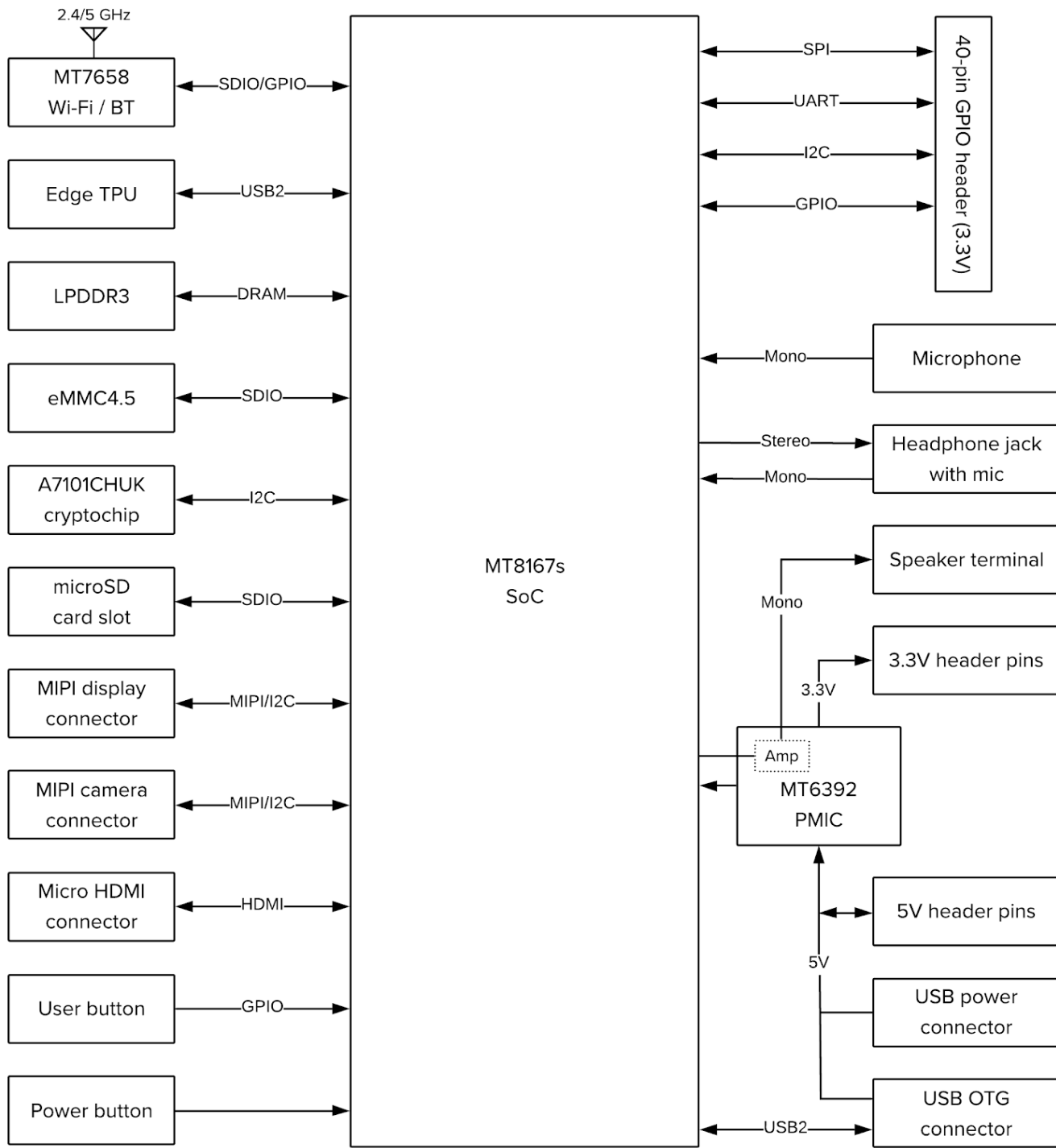

Figure 1. Dev Board Mini functional block diagram

2 Mechanical dimensions

Table 2. Physical specifications

Measurement	Value
Size	64.0 × 48.0 × 14.6 mm
Weight	25.5 g

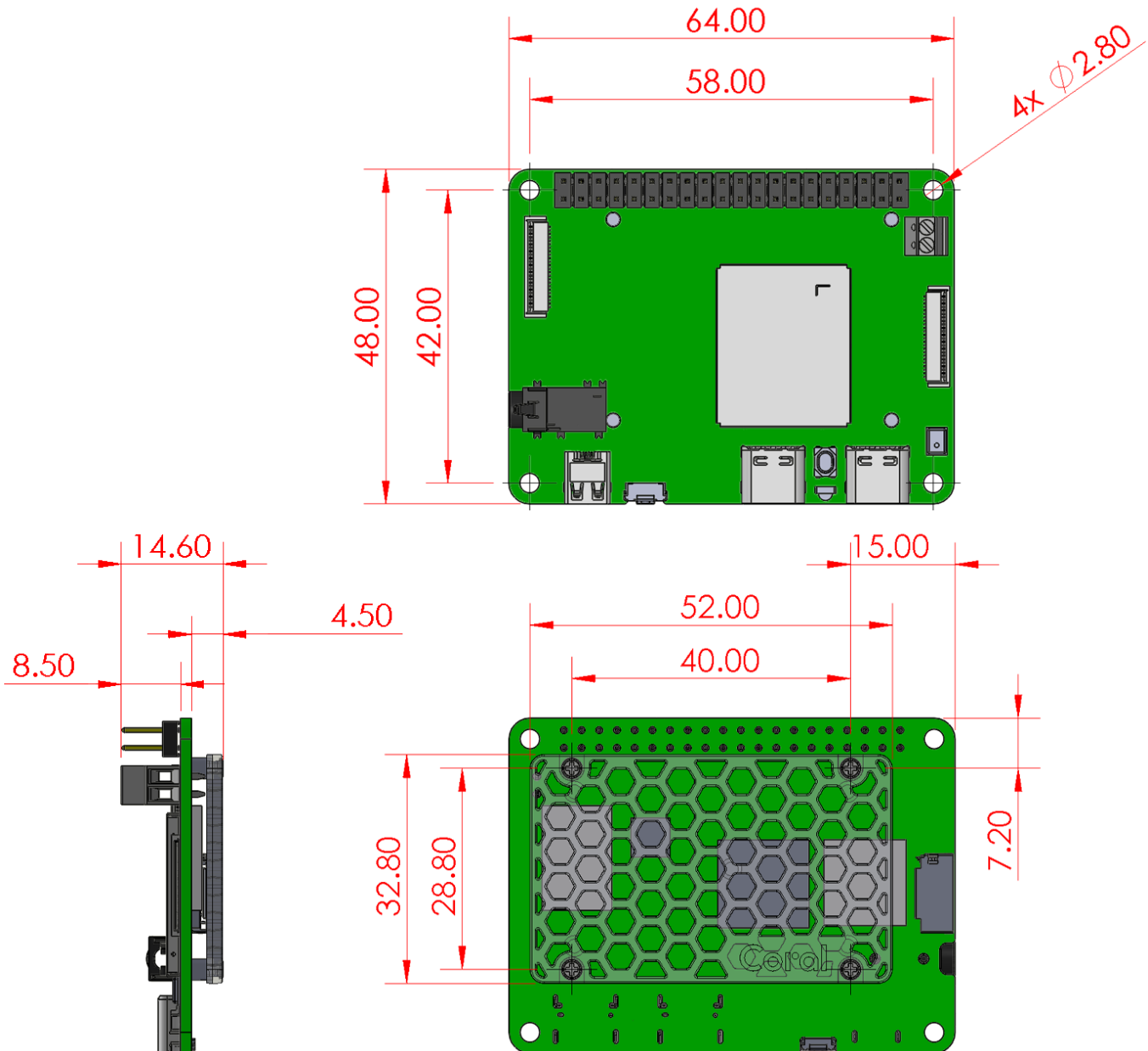

Figure 2. Dev Board Mini dimensions

3 Electrical specifications

3.1 Recommended operating conditions

Table 3. Board operating conditions

Parameter	Min	Typical	Max
Board supply voltage (VIN)	4.5 V	5 V	5.5 V
General purpose I/O voltage (VCC3IO)	2.97 V	3.3 V	3.63 V
Operating temperature	0 °C	–	50 °C
Storage temperature	-40 °C	–	85 °C

Typical operation is based on a 5 V / 2 A power supply via USB. Each USB port allows a max current of 2 A. If you need additional power, you can connect power to both USB ports. For more details, see section [5.1 Power supply](#).

3.2 Logic threshold levels

Table 4. Digital I/O (40-pin header) logic thresholds

Parameter	Output		Input	
	Low-level max (VOL)	High-level min (VOH)	Low-level max (VIL)	High-level min (VIH)
GPIO pins	0.4 V	VCC3IO - 0.3 V	0.8 V	2.0 V

Each I/O pin supports a max current of 16 mA. However, default drive strengths may be lower and vary between pins. For details, see section [4.9 GPIO header](#).

3.3 Power consumption

The power consumed by the board varies based on a variety of system behaviors, including the extent to which the Edge TPU is being used. Typical scenarios that we've tested show average power peaks around 3 W.

Beware that, depending on the type of ML model you're using, the Edge TPU can cause significant spikes in current draw. For more details about the Edge TPU power consumption, see the [Coral Accelerator Module datasheet](#).

4 Board peripherals

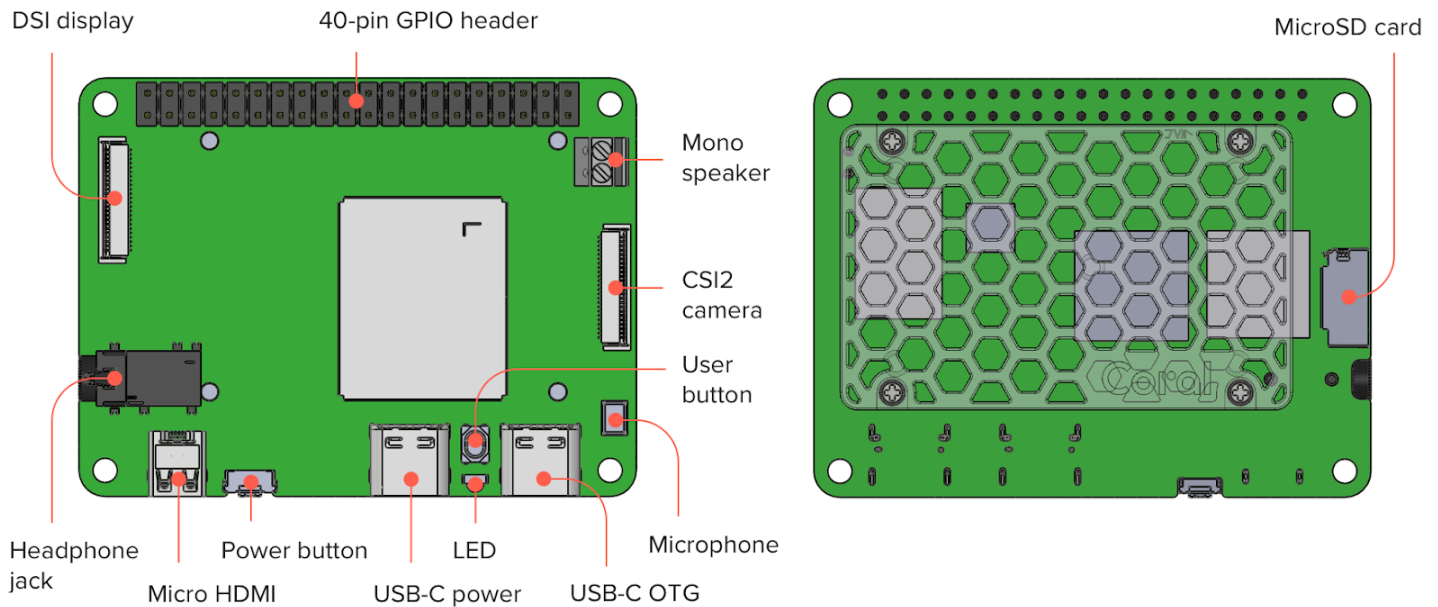

Figure 3. User interface and peripheral components

4.1 Buttons

The board has two tactile switch buttons:

- **Power button:** This controls board power. If only the USB-C power port is connected, you must press this button to boot the board (press firmly). You can power-off the board by pressing it again. If the USB OTG port is connected to power, then the board boots automatically and this button instead reboots the board (see section [5.1 Power supply](#)).
- **User button:** This does nothing by default. You can program your own behavior with GPIO2 ("gpio389"; active low).

4.2 USB-C ports

The board has two USB ports:

- **USB-C power:** This is for power input only.
- **USB-C OTG:** This supports USB 2.0 and is a dual-role port, allowing the board to operate as a host (such as when you connect a keyboard) or as a peripheral (such as when you connect to a computer to flash the board). This can also power the board for "always on" operation—the board will not fully shut down (see section [5.1 Power supply](#)).

4.3 LED

Table 5. Description of the on-board LED colors

LED color	Meaning
Orange	The system is booting up. If it remains orange more than a minute, there might be a boot failure (except when booting for the first time after a flash, which takes a few minutes).
Green	The system is booted (ready for login).
Red	The system is in fastboot mode (ready to flash).

4.4 Mono speaker terminal

This is a 2-pin 2.54 mm-pitch terminal connector for a 4Ω/8Ω mono speaker (up to 1 W). Wire polarity is indicated in figure 4.

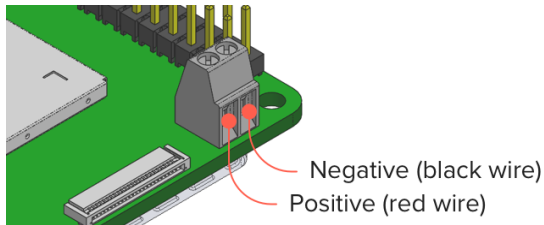

Figure 4. Mono speaker terminal

4.5 Headphone jack

This is a CTIA compliant audio jack. It supports stereo audio output and mono microphone input. By default, the microphone expects analog input. You can reconfigure the mux to use a digital microphone like this:

```
amixer -c 0 cset name="AIF TX Mux" 1
```

To make this permanent across boots, you should update the EnableSequence for the "Headphone" configuration in `/usr/share/alsa/ucm/excelsior-card/HiFi.conf`.

4.6 Microphone

This is an on-board digital PDM microphone. It shares the same capture device as the headphone jack, using the headphone jack as a switch. That is, if you plug in a headphone, this PDM microphone is disabled.

4.7 Micro HDMI port

This port supports HDMI 1.4a with a micro connector, and a resolution up to 1920x1080.

4.8 MicroSD slot

The microSD card supports SD/SDHC/MMC (card capacities up to 32 GiB) and meets the SDIO 2.0/3.0 standard to provide expanded memory for the system. Insert the card with the contacts facing up (toward the board).

4.9 GPIO header

All GPIO pins can be configured for input or output. The Mendel system image includes a default configuration to enable PWM, I2C, and UART on some pins. For details about the default pin configuration, see table 6.

You can interact with each pin using standard Linux interfaces such as device files (`/dev`) and sysfs files (`/sys`). For more information, see the guide to [Connect to the Dev Board Mini I/O pins](#).

The default driving current for most GPIO pins is 2-4 mA. If you need a stronger current (up to 16 mA) or want to change the default state (shown in table 7), you can provide a device tree overlay. However, pins 8, 10, 29, 31, and 37 are routed through a level shifter with a weak fixed pull-up that reduces their drive strength, so should not drive resistive loads directly.

For information about the header pins voltage levels and logic thresholds, see section [3 Electrical specifications](#).

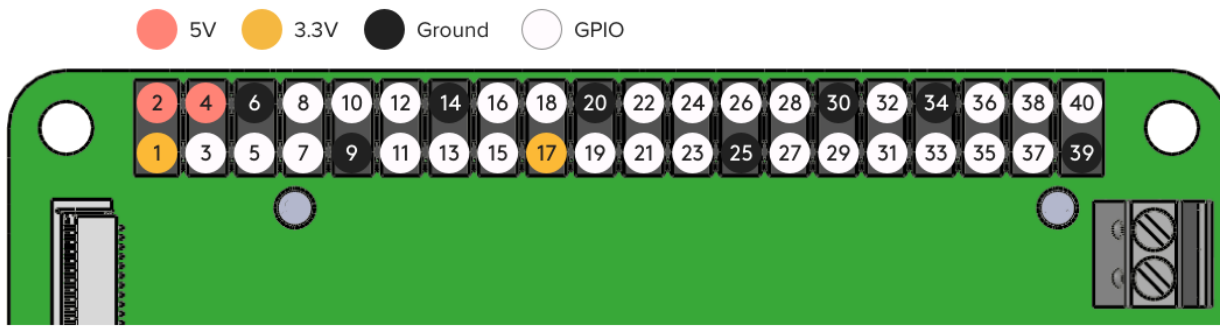

Figure 5. Basic pin layout for the 40-pin header

Note: Pins 8, 10, 29, 31, and 37 should not be used to drive resistive loads directly, due to weak drive strength.

Table 6. Default GPIO configuration in Mendel (device names correspond to files in the Linux device interface)

SoC pin	Device name	Default function	Pin		Default function	Device name	SoC pin
		+3.3 V power	1	2	+5 V power		
GPIO52	i2c-3	I2C1_SDA	3	4	+5 V power		
GPIO53	i2c-3	I2C1_SCL	5	6	Ground		
GPIO22	gpio409	GPIO22	7	8	UART0_TX	ttyS0	GPIO63
		Ground	9	10	UART0_RX	ttyS0	GPIO62
GPIO9	gpio396	GPIO9	11	12	GPIO36	gpio423	GPIO36
GPIO10	gpio397	GPIO10	13	14	Ground		
GPIO11	pwmchip0.2	PWM_C	15	16	GPIO0	gpio387	GPIO0
		+3.3 V power	17	18	GPIO1	gpio388	GPIO1
GPIO4	spidev0	SPI_MO	19	20	Ground		
GPIO3	spidev0	SPI_MI	21	22	GPIO7	gpio394	GPIO7
GPIO6	spidev0	SPI_CLK	23	24	SPI_CSB	spidev0.0	GPIO5
		Ground	25	26	GPIO8	gpio395	GPIO8
GPIO60	i2c-0	I2C2_SDA	27	28	I2C2_SCL	i2c-0	GPIO61
GPIO65	ttyS1	UART1_TX	29	30	Ground		
GPIO64	ttyS1	UART1_RX	31	32	PWM_A	pwmchip0.0	GPIO12
GPIO25	pwmchip0.1	PWM_B	33	34	Ground		
GPIO37	gpio424	GPIO37	35	36	GPIO13	gpio400	GPIO13
GPIO45	gpio432	GPIO45	37	38	GPIO38	gpio425	GPIO38
		Ground	39	40	GPIO39	gpio426	GPIO39

For GPIO programming details, see the guide to [Connect to the Dev Board Mini I/O pins](#).

Table 7. GPIO pin default states

Pin	Default function	Default state
3	I2C1_SDA	High (4.7K pull-up)
5	I2C1_SCL	High (4.7K pull-up)
7	GPIO22	Low
8	UART0_TX	High (10K pull-up)
10	UART0_RX	High (10K pull-up)
11	GPIO9	Low
12	GPIO36	Low
13	GPIO10	Low
15	PWM_C	Low
16	GPIO0	Low
18	GPIO1	Low
19	SPI_MO	Low
21	SPI_MI	Low
22	GPIO7	Low

Pin	Default function	Default state
23	SPI_CLK	Low
24	SPI_CSB	Low
26	GPIO8	Low
27	I2C2_SDA	High (4.7K pull-up)
28	I2C2_SCL	High (4.7K pull-up)
29	UART1_TX	High (10K pull-up)
31	UART1_RX	High (10K pull-up)
32	PWM_A	Low
33	PWM_B	Low
35	GPIO37	Low
36	GPIO13	Low
37	GPIO45	High (10K pull-up)
38	GPIO38	Low
40	GPIO39	Low

4.10 Camera connector (CSI)

The MIPI CSI-2 camera connector is a 24-pin flex cable connector that's designed for the [Coral Camera](#). It provides 4 lanes with a maximum lane speed of 1 Gb/s. For more detail, see the [Camera datasheet](#).

Table 8. MIPI CSI connector pinout

Pin	Name	Description
1	GND	
2	MIPI_CSI_D0_N	Differential data N
3	MIPI_CSI_D0_P	Differential data P
4	GND	
5	MIPI_CLK_N	Differential clock N
6	MIPI_CLK_P	Differential clock P
7	GND	
8	MIPI_CSI_D1_N	Differential data N
9	MIPI_CSI_D1_P	Differential data P
10	GND	
11	MIPI_CSI_D2_N	Differential data N
12	MIPI_CSI_D2_P	Differential data P

Pin	Name	Description
13	GND	
14	MIPI_CSI_D3_N	Differential data N
15	MIPI_CSI_D3_P	Differential data P
16	GND	
17	CAM_PWDNB	Camera power down (active low)
18	CAM_CLK (NC)	Not connected
19	GND	
20	CAM_I2C_SCL	I2C clock, has pull-up (4.7K)
21	CAM_I2C_SDA	I2C data, has pull-up (4.7K)
22	CAM_VSYNC (NC)	Not connected
23	CAM_RESETB	Camera reset (active low)
24	3.3V	

4.11 Display connector (DSI)

The MIPI DSI display connector is a 24-pin flex cable connector with 4 lanes and a maximum lane speed of 1 Gb/s.

Table 9. MIPI DSI connector pinout

Pin	Name	Description
1	GND	
2	DSI_TDP2	Differential data P
3	DSI_TDN2	Differential data N
4	GND	
5	DSI_TDP1	Differential data P
6	DSI_TDN1	Differential data N
7	GND	
8	DSI_TCP	Differential clock P
9	DSI_TCN	Differential clock N
10	GND	
11	DSI_TDPO	Differential data P
12	DSI_TDN0	Differential data N

Pin	Name	Description
13	GND	
14	DSI_TDP3	Differential data P
15	DSI_TDN3	Differential data N
16	GND	
17	I2C_SCL	I2C clock for touch, has pull-up (4.7K)
18	I2C_SDA	I2C data for touch, has pull-up (4.7K)
19	GND	
20	DSI_RESETB	Display reset (active low), 1.8 V
21	LED_PWM	PWM signal for brightness control, 1.8 V
22	DSI_TE	Tearing effect signal, 1.8 V
23	TS_INTB	Interrupt for touch screen (active low), 3.3 V
24	TS_RESETB	Reset for touch screen (active low), 3.3 V

5 Board operation

The factory setting includes [Mendel Linux](#) flashed on the eMMC memory. It includes all the software you need to run TensorFlow Lite models on the Edge TPU. To set up your board, see [Get started with the Dev Board Mini](#).

5.1 Power supply

The board requires a DC power supply that can provide 2 A at 5 V.

Caution: If your power supply cannot deliver 2 A, the board will probably operate normally while the Edge TPU is idle, but it could then drop the Edge TPU interface and crash your program when executing an ML model.

5.1.1 Power from the USB ports

You can power the board by connecting a DC power supply to either of the two USB-C ports. Each USB line includes an ideal diode to set a max current of 2 A, allowing up to 10 W of power from a single input. You may connect a separate power supply to each port, providing a maximum of 20 W for the board.

Beware that the board behaves differently depending on which port you use to supply power:

- **USB power port:** If you connect power here only, you must firmly press the power button to boot-up the board. Once the board is booted, you can press the power button to safely shut it down (equivalent to `sudo shutdown`).
- **USB OTG port:** If you connect power here (alone or in addition to the power port), the board boots up immediately and operates in "always on" mode. That is, you cannot completely shut down the board when the OTG port is connected to power. If you shut down the operating system or press the power button, it will reboot.

To completely power-off the board, you must deliver power with the power port only, and then press the power button or run `sudo shutdown now`. When the board's LED turns off, you can disconnect the power.

Tip: If you want to run the board for an extended period of time in "always on" mode (powered via USB OTG), you can later shut down the board safely if you connect a second power source to the power port, then unplug the OTG port, and then press the power button.

Caution: Do not unplug the board while it is running. Doing so could corrupt the system image.

5.1.2 Power from the GPIO header

You can power the board by connecting a DC power supply to the 5 V pins on the GPIO header.

Warning: Do not use the 5 V pins as a power input for the board if you also connect either USB port to a power supply. If you do, current will flow between the two sources, which degrades the USB power supply's ability to power the board, and can cause damage to the power supply at the 5 V pin, potentially causing fire and serious injury.

5.1.3 Power for add-on boards

When powering the board from one USB port, the 5 V pins on the GPIO header can deliver up to 6 W (1.2 A) for accessories such as add-on boards (Raspberry Pi HATs). The 3.3 V pins can deliver up to 330 mW (100 mA).

If you need more power for accessories on the GPIO header, you can increase the total power by connecting a separate power supply to each USB port. Doing so allows the 5 V header pin to deliver a maximum of 16 W to the add-on board (if both power supplies provide 10 W each).

5.2 Shell and serial console

You can access the board's shell terminal over SSH after you place your OpenSSH public key on the board. To simplify this process, we recommend you use the MDT command line tool, as described in [Get started with the Dev Board Mini](#).

You can also connect to the serial console with UART pins on the GPIO header (pins 8 and 10), using a USB-to-TTL cable. For instructions, see [Connect to the Dev Board Mini's serial console](#).

6 Document revisions

Table 10. History of changes to this document

Version	Changes
1.1 (Dec 2020)	Increased power requirements to 2 A to avoid possible crashes caused by large total current transients that include the Edge TPU. Corrected the device name for GPIO pin 18, and other name changes for consistency, in table 6. Added the orange LED behavior in table 5 (requires system update after unboxing).
1.0 (Nov 2020)	Initial release