

PART NO.	ENG. NO.	PACKAGING
02-06-1131	1855-(P901)	18550000-PK
02-06-1132	1855-(P901)L	PK-1190-003
02-06-5138	1855-(P561)	18550000-PK
02-06-5139	1855-(P561)L	PK-1190-003
02-06-5130	1855-(P550)	18550000-PK
02-06-5135	1855-(P550)L	PK-1190-003
02-06-5147	1855-(P228)	18550000-PK
02-06-5148	1855-(P228)L	PK-1190-003
02-06-1141	1855-1(P901)	18550000-PK
NOT TOOLED	1855-1(P901)L	PK-1190-003
02-06-1143	1855-(P901)1	PK-18550001-PK

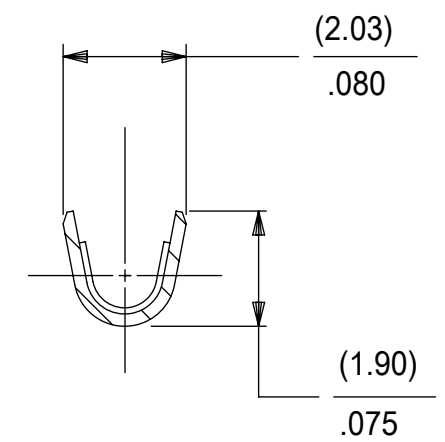
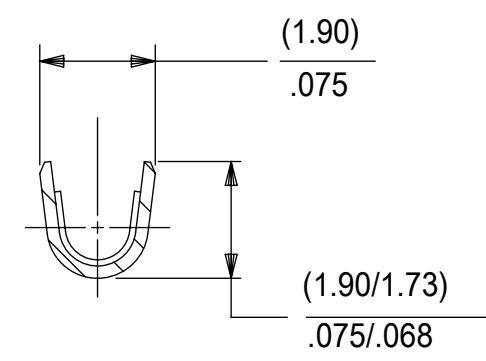
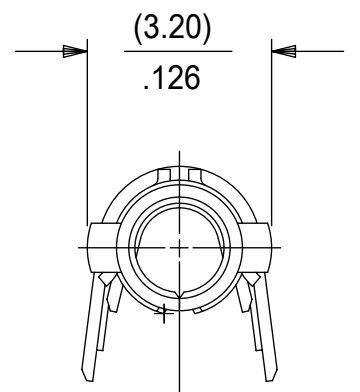
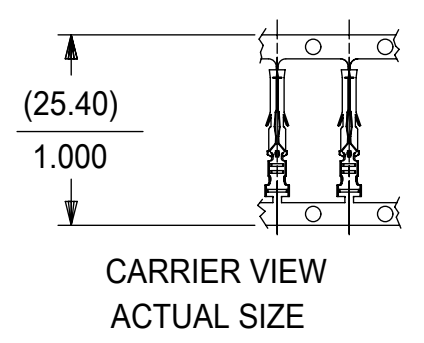

**LEGEND**

1855-\*(\*\*\*)\*

BLANK=WITH LOCKING TABS  
1=WITHOUT LOCKING TABS

P=PREPLATE  
BLANK=POSTPLATE

FORM  
BLANK=CHAIN  
1=CHAIN WITH INTERLEAF  
PAPER ON REEL.  
L=LOOSE  
FINISH CODE

- NOTES:
- MATERIAL: BRASS
  - FINISHES:
    - 901 HOT TIN DIP (.00051)/.000020 MIN.
    - 228 SELECT GOLD PLATE (.00075/.000030 MIN. IN CONTACT AREA, SELECT TIN (.00250)/.000100 MIN. IN CRIMP AREA OVER (.00125)/.000050 MIN. NICKEL OVERALL
    - 561 SELECT GOLD PLATE (.00076)/.000030 MIN. IN CONTACT AREA, (.00127)/.000050 MIN. NICKEL OVERALL.
    - 550 SELECT GOLD PLATE (.00038)/.000015 MIN. IN CONTACT AREA, OVER (.00076)/.000030 MIN. NICKEL OVERALL WITH (.00025)/.000010 MAX. GOLD FLASH OVERALL.
  - PRODUCT SPECIFICATION: PS-02-06
  - PACKAGE INFORMATION: SEE CHART
  - TERMINAL FOR USE WITH (1.57)/.062 DIA. SERIES HOUSINGS AND WILL ACCEPT 24 THRU 30 AWG WIRE WITH (1.02/2.29)/.040/.090 INSULATION DIAMETER.
  - PARTS CONFORM TO CLASS B REQUIREMENTS OF COSMETIC SPECIFICATION PS-45499-002.
  - MARKING MAY VARY ON PARTS, CONSULT FACTORY.
  - TIP GEOMETRY IS TOOL DEPENDENT. EITHER GEOMETRY IS ACCEPTABLE.

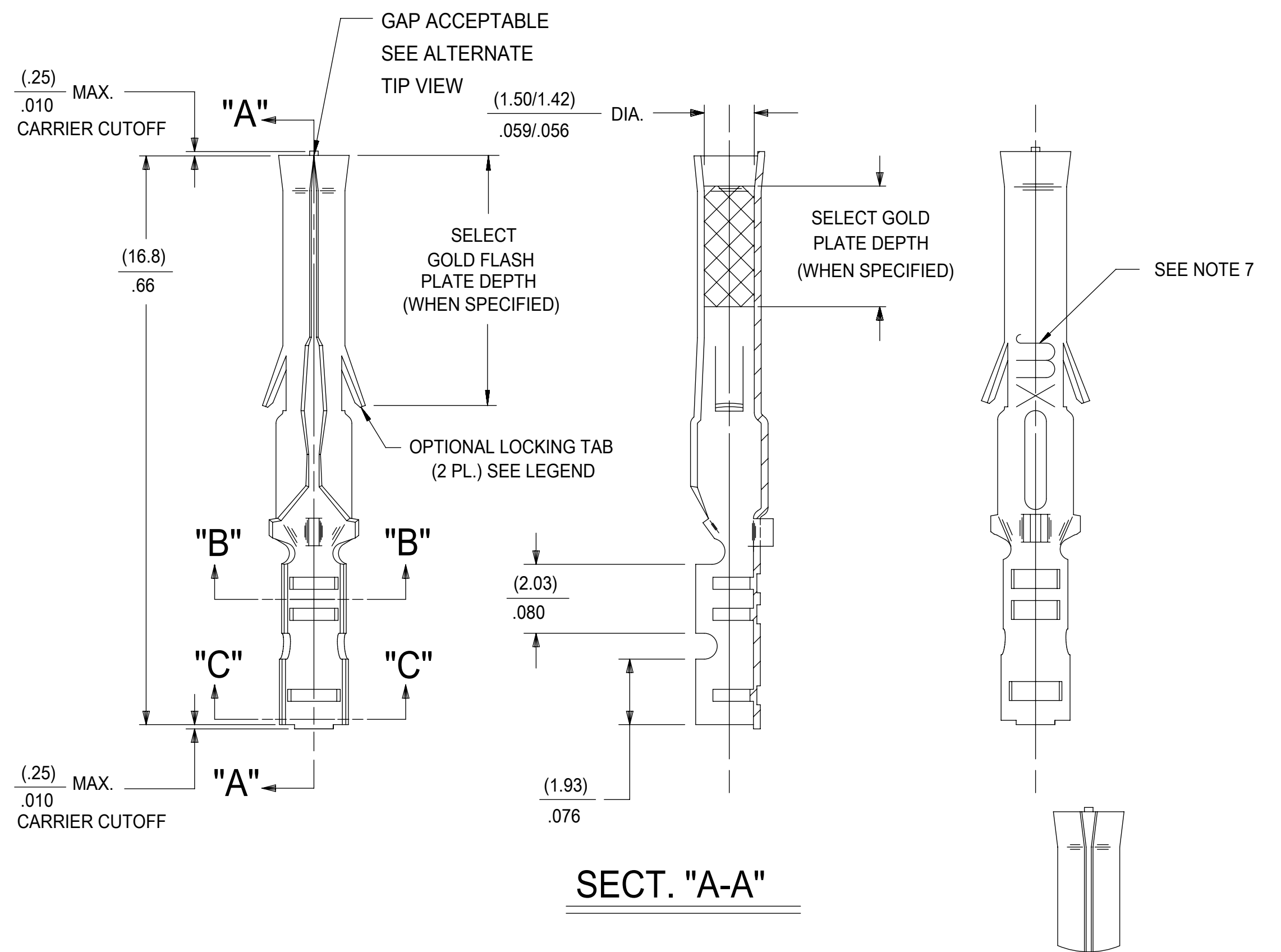

**SECT. "A-A"**

ALTERNATE TIP GEOMETRY  
SEE NOTE 8

SYMBOLS										THIS DRAWING CONTAINS INFORMATION THAT IS PROPRIETARY TO MOLEX ELECTRONIC TECHNOLOGIES, LLC AND SHOULD NOT BE USED WITHOUT WRITTEN PERMISSION									
DIMENSION UNITS					SCALE					CURRENT REV DESC: ADD CHAIN PK SPEC									
MM/IN					NTS					EC NO: 614240 DRWN: JEHRISMAN 2019/03/22 CHK'D: FSMITH 2019/05/10 APPR: FSMITH 2019/05/10 INITIAL REVISION: DRWN: GEP 1987/09/17 APPR: RAS 1987/09/17									
GENERAL TOLERANCES (UNLESS SPECIFIED)																			
4 PLACES ±					MM					INCH					PRODUCT CUSTOMER DRAWING DOCUMENT NUMBER: SD-1855-X DOC TYPE: PSD DOC PART: 001 REVISION: AP3				
3 PLACES ±					± 0.01					± 0.014									
2 PLACES ±					± 0.25					± 0.014					MATERIAL NUMBER: SEE TABLE CUSTOMER: GENERAL MARKET SHEET NUMBER: 1 OF 1				
1 PLACE ±					± 0.35					±									
0 PLACES ±					±					±					DRAFT WHERE APPLICABLE MUST REMAIN WITHIN DIMENSIONS				
ANGULAR TOL ± 0.5 °					THIRD ANGLE PROJECTION					DRAWING: C-SIZE									