



Read this document carefully before using this device. The guarantee will be expired by device damages if you don't attend to the directions in the user manual. Also we don't accept any compensations for personal injury, material damage or capital disadvantages.

# ENDA EPC9513 Series Programmable Profile Controller

Thank you for choosing EPC9513 series programmable profile controller.

- ▶ 96x96mm sized.
- ▶ 3,5 inches TFT , graphic and 5 digit display.
- ▶ Selectable TC, RTD, NTC, R, mA, V or mV inputs.
- ▶ Input offset feature.
- ▶ 32 point linearization for analog inputs.
- ▶ Selectable relay, SSR, motorized valve or analog outputs.
- ▶ Selectable , input proportional transmitter output(mA or V).
- ▶ 50ms sampling time.
- ▶ PID control.
- ▶ PID selftune.
- ▶ PID auto-tune.

**⚠ Selftune automatic PID calculation or manually enter PID parameters if known.**

- ▶ Soft-Start feature.
- ▶ 24Vdc for sensor supply.
- ▶ 16 program and 8 step for profile control.
- ▶ Selectable Single Setpoint Mode or Profile Control Mode.
- ▶ Digital inputs for profile control.
- ▶ In case of sensor failure manually , periodical or auto-periodical control can be selected.
- ▶ Security levels for menu and configuration pages.
- ▶ RS485 ModBus protocol communication feature.(optional)
- ▶ CE marked according to European Norms.

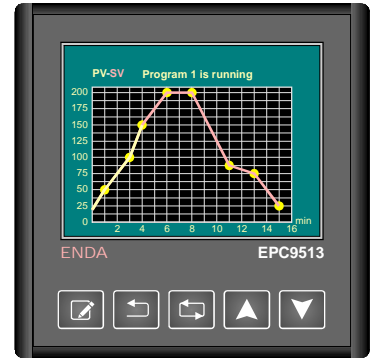

Order Code : EPC 9 5 1 3

**⚠ Please see EPC9513 Series Modbus Address Map and Connection Diagram Guide for Modbus feature.**

Analog Inputs						
Input Type	Range	Accuracy	Input Resist.	Cable Color	Standart	
TC	B (Pt30Rh-Pt6Rh)	200,0 ... 1800,0°C 392,0 ... 3272,0°F	% ±0.1 and ±2°C (3,6°F)	Ri > 100k	+ undefined - white	EN 60584
	E (NiCr-Con)	-100,0 ..... 900,0°C -148,0 ... 1652,0°F	% ±0.1 and ±0,5°C (1°F)		+ purple - white	
	J (Fe-Con)	-100,0 ..... 900,0°C -148,0 ... 1652,0°F	% ±0.1 and ±0,5°C (1°F)		+ black - white	
	K (NiCr-Ni)	-100,0 ... 1300,0°C -148,0 ... 2372,0°F	% ±0.1 and ±0,5°C (1°F)		+ green - white	
	L (Fe-Con)	-100,0 ..... 900,0°C -148,0 ... 1652,0°F	% ±0.1 and ±1,5°C (2,7°F)		+ red - blue	DIN43710
	N (NiCrSi-NiSi)	-200,0 ... 1300,0°C -328,0 ... 2372,0°F	% ±0.1 and ±0,5°C (1°F)		+ lilac - white	EN 60584
	R (Pt13Rh-Pt)	0,0 ... 1700,0°C 32,0 ... 3092,0°F	% ±0.1 and ±1°C (1,8°F)		+ orange - white	
	S (Pt10Rh-Pt)	0,0 ... 1700,0°C 32,0 ... 3092,0°F	% ±0.1 and ±1°C (1,8°F)		+ orange - white	
	T (Cu-Con)	-250,0 ..... 300,0°C -418,0 ..... 572,0°F	% ±0.1 and ±0,5°C (1°F)		+ brown - white	
	U (Cu-Con)	-200,0 ..... 400,0°C -328,0 ..... 752,0°F	% ±0.1 and ±0,5°C (1°F)		+ red - brown	DIN43710
RTD	Pt100	-200,0 ..... 850,0°C -328,0 ... 1562,0°F -100,00 ... 160,00°C -148,00 ... 320,00°F	% ±0.1 and ±0,5°C (1°F)	Ri > 100k	Sensor current 250µA	EN 60751
NTC	NTC	-60,0 ..... 150,0°C -76,0 ..... 302,0°F	% ±0.1 and ±0,5°C (1°F)	Ri > 100k		
mA	0 - 20mA	-32768 ... 32767	% ±0.1 and ±1 digit	Ri = 50		
	4 - 20mA					
mV	0 - 150mV	-3276,8 ... 3276,7	% ±0.1 and ±20µV	Ri > 100k		
	0 - 5V					
V	1 - 5V	-327,68 ... 327,67	% ±0.1 and ±1 digit	Ri > 100k		
	0 - 10V					
	0 - 550		% ±0.2 and ±0.1	Ri > 100k	Sensor current 250µA	
	0 - 10k		% ±0.5 and ±10	Ri > 100k		

DIGITAL INPUTS (In order to use for profile control process)	
Start-Stop Input / Pause-Resume Input / Previous Program Input / Next Program Input	5V or 30V pulse , Ri=100k

OUTPUTS	
Control/A.3/Valve On	250V AC, 2A . Selectable as NO+NC.10.000.000 switch without load and 200.000 switch under 250V AC 2A (resistive load)
Alarm 1	250V AC, 2A . Selectable as NO+NC.10.000.000 switch without load and 200.000 switch under 250V AC 2A (resistive load)
Alarm 2/Valve Off	250V AC, 2A . Selectable as NO.10.000.000 switch without load and 200.000 switch under 250V AC 2A (resistive load)
SSR	Max. 40mA , 0 - 12Volt , short-circuit protection.
mA	0 - 20mA or 4 - 20mA DC, % ±0,5 (Max. load resistance is 750Ω.)
V	0 - 10V DC, % ±0,5 Max. 30mA (short-circuit protection.)

ELECTRICAL CHARACTERISTICS	
Supply	90-250V AC, 50/60Hz
Power consumption	Max. 7VA
Wiring	2.5mm² screw-terminal
EMC	EN 61326-1: 2013
Safety requirements	EN 61010-1: 2010 (Pollution degree 2 , overvoltage category II)

ENVIRONMENTAL CONDITIONS	
Ambient/storage temp.	0 ... +50°C/-25 ... 70°C
Max. Relative humidity	Relative humidity 80% for temperatures up to 31°C , decreasing linearly to 50% relative humidity at 40°C.
Rated pollution degree	According to EN 60529 Front panel : IP65 , Rear panel : IP20
Height	Max. 2000m

**⚠ Do not use the device in locations subject to corrosive and flammable gases.**

HOUSING	
Housing type	Suitable for flush-panel mounting.
Dimensions	G96xY96xD81mm
Weight	Approx. 400g.
Enclosure material	Self extinguishing plastics.

**⚠ While cleaning the device , solvents(thinner,gasoline,acid etc.) or corrosive materials must not be used.**

## DIMENSIONS

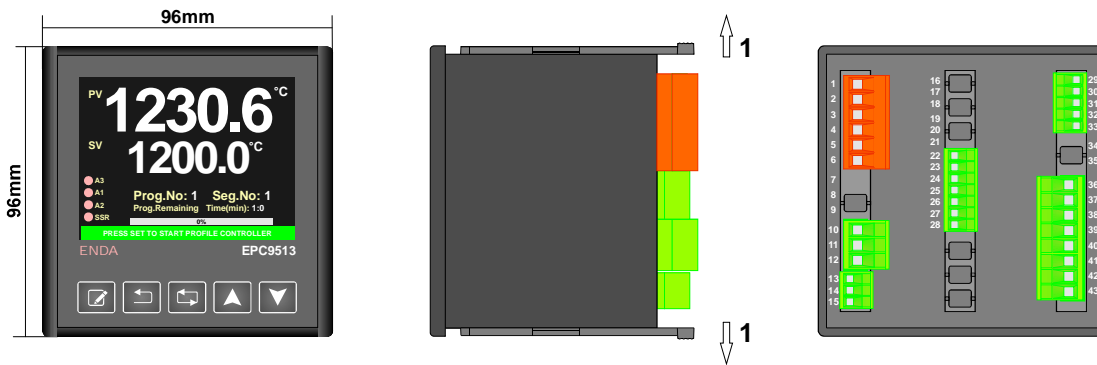

## PANEL CUT-OUT

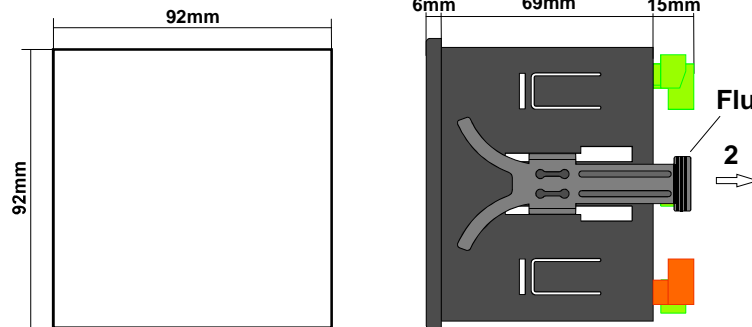

### Flush mounting clamp

For removing the device from panel :  
 - While pressing both flush mounting clamps of the device in direction 1 , pull it in direction 2.

Not :

- 1) Panel thickness should be maximum 7mm.
- 2) If there is no 60mm free space at the back side of the device , it would be difficult to remove it from panel.

## CONNECTION DIAGRAM



ENDA EPC9513 is intended for installation in control panels. Make sure that the device is used only for intended purpose. The electrical connections must be carried out by a qualified staff and must be according to the relevant locally applicable regulations. During an installation , all of the cables that are connected to the device must be free of electrical power. The device must be protected against inadmissible humidity , vibrations , severe soiling and make sure that the operation temperature is not exceeded. The cables should not be close to the power cables or components.

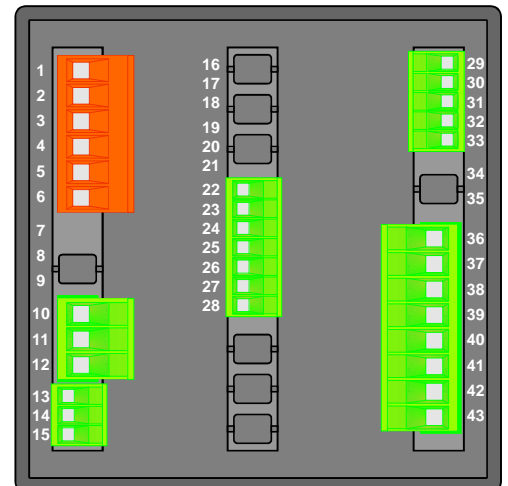
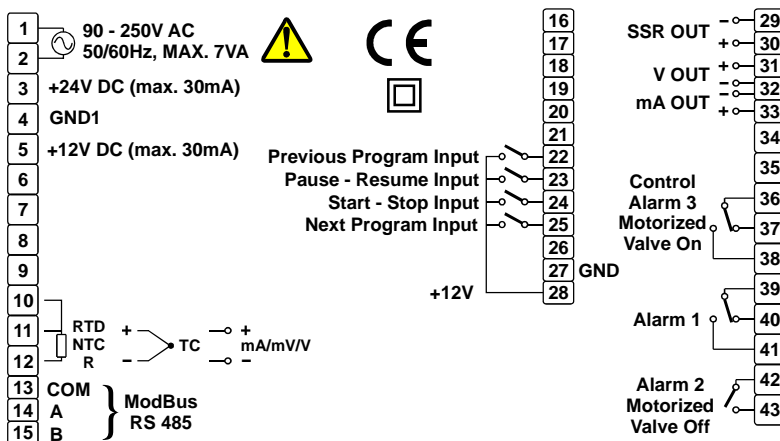

### SUPPLY VOLTAGE

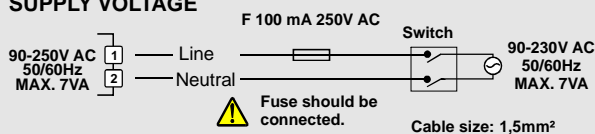

Logic output of the instrument is not electrically insulated from the internal circuits. Therefore , when using grounding thermocouple , do not connect the logic output terminals to the ground.

- Not :
- 1) Main supply cords shall meet the requirements of IEC 60227 or IEC60245.
  - 2) In accordance with safety regulations, the power supply switch shall bring the identification of the relevant instrument and it should be easily accessible by the operator.

Holding screw  
0.4-0.5Nm

Equipment is protected throughout  
by DOUBLE INSULATION.

## HOME SCREEN

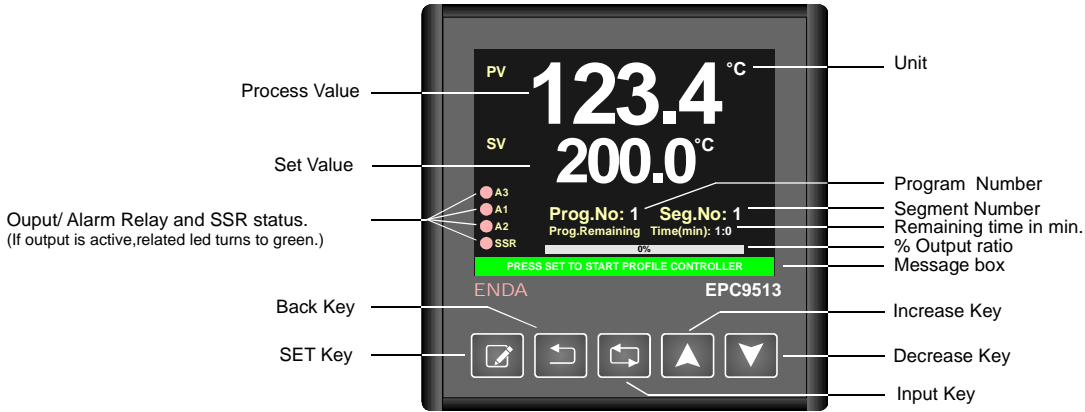

- SET Key :** Start/Stop profile controller in "Profile Controller Mode", Select/Unselect parameter for increase/decrease parameter value in "Programming Mode". Change SV in "Single Setpoint Mode".
- Back Key :** Return previous page in "Programming Mode".
- Enter Key :** Enter main menu and open sub pages and transition between sub pages in "Programming Mode". Pause/Resume profile controller in "Profile Controller Mode".
- Increase Key :** Transition between parameters (when parameter background is red) and increase selected parameter value (when parameter background is green) in "Programming Mode".
- Decrease Key :** Transition between parameters (when parameter background is red) and decrease selected parameter value (when parameter background is green) in "Programming Mode".



- NOTE 1 :** Device must be in "Profile Control Mode" in order to start/stop profile control by pressing Set Key.
- NOTE 2 :** When device in "Single Setpoint Mode", **Prog.No** , **Seg.No** ve **Prog.Remaning Time(min)** informations are not shown on home screen.
- NOTE 3 :** If Increase Key is held down while the device is powered up , factory parameters will be restored.
- NOTE 4 :** "Single Setpoint Mode" can be selected under "Profile Controller Configuration Page" sub menu , device make a control related to SV , which can be adjusted on home screen in "Single Setpoint Mode".

## Adjusting Device Set Value in Single Setpoint Mode

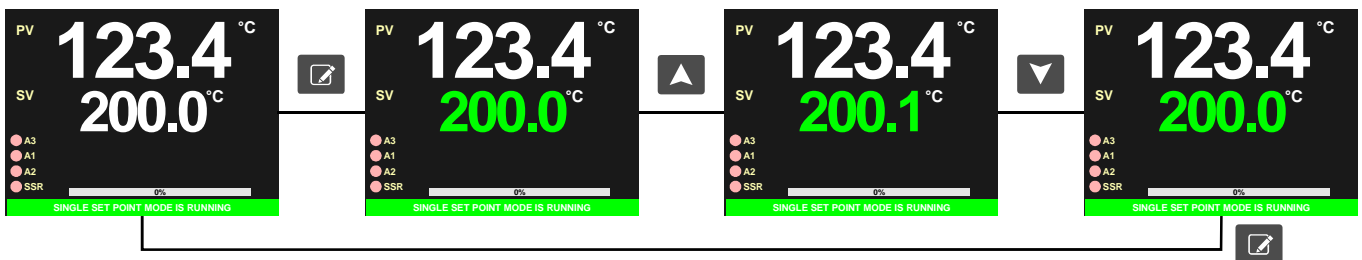

If Set Key pressed once , SV's color will be green. In this case SV is adjusted by pressing Increase/Decrease keys.  
If Set Key pressed again or by waiting 3 seconds , SV's color will be white on home screen.

## Profile Control Mode

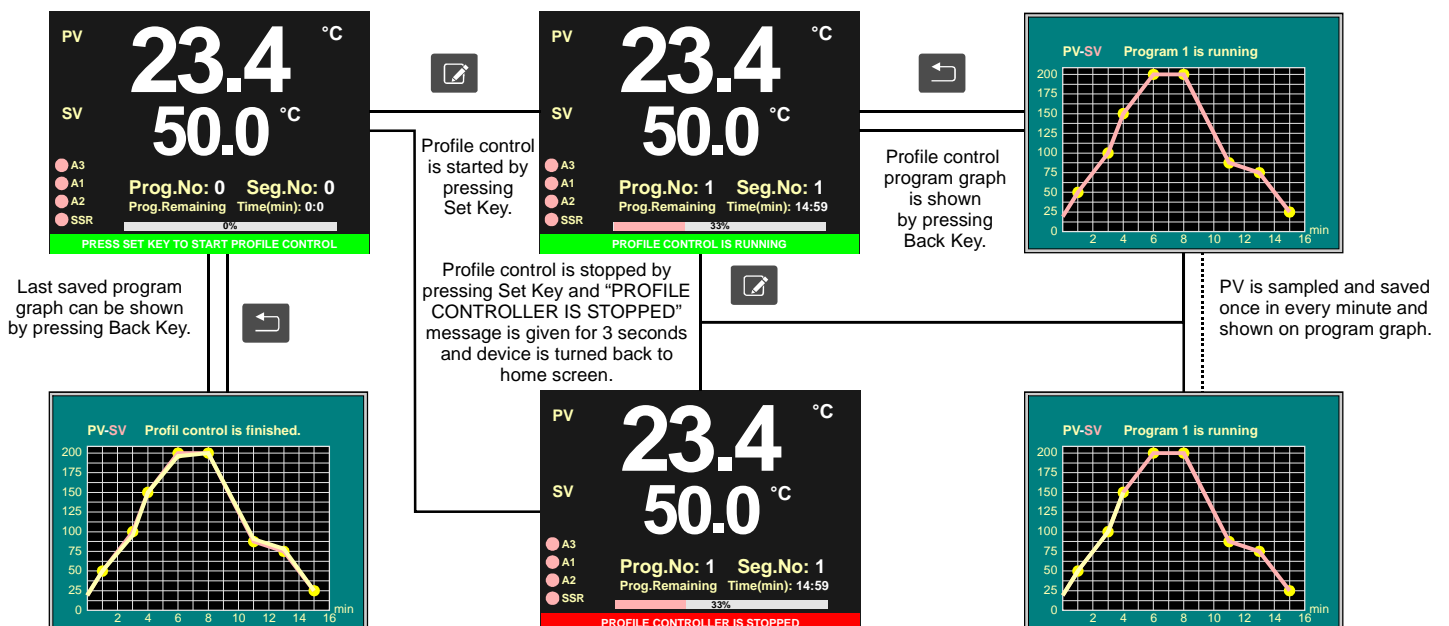

# Programming

Home Screen

**EPC9513 PROFILE CONTROLLER**

- Input Configuration Page
- Output Configuration Page
- Alarm Configuration Page
- PID Control Configuration Page
- Communication Configuration Page
- Security Configuration Page
- Calibration Page
- Profile Controller Configuration Page

Main menu is opened and "Programming Mode" is started by pressing Enter Key for 2 seconds.

Desired sub menu is selected by pressing Increase/Decrease Keys.

Selected sub menu is opened by pressing Enter Key.  
Selected sub menu can be opened if permission is given from "Security Configuration Page".

If Back Key is pressed or by waiting 10 seconds , parameters will be saved and device turns back to home screen.

**NOT 5 :** If power failure is occurs while device is programming , parameters won't be saved.

## Programming Inputs (Input Configuration Page)

Desired parameter is selected by pressing Increase/Decrease Keys. Background of selected parameter turns red.

If SET Key is pressed , background of selected parameter turns to green and selected parameter can be adjusted to desired value.

If SET Key is pressed again , background of selected parameter turns to red and exits from parameter adjustment.

If Back Key pressed or by waiting 10 seconds , Input Configuration Page is closed and device turns back to main menu.

Input Conf Digital Inputs Conf Linearization Table Conf

Input 1 Type **J Type Thermocouple**

Scale Minimum

Scale Maximum

Unit

Input offset

Coefficient of digital filter

Decimal Point

Minimum Set Value

Maximum Set Value

Input Conf Digital Inputs Conf Linearization Table Conf

Input 1 Type **J Type Thermocouple**

Scale Minimum

Scale Maximum

Unit

Input offset

Coefficient of digital filter

Decimal Point

Minimum Set Value

Maximum Set Value

Input Conf Digital Inputs Conf Linearization Table Conf

Input 1 Type **K Type Thermocouple**

Scale Minimum

Scale Maximum

Unit

Input offset

Coefficient of digital filter

Decimal Point

Minimum Set Value

Maximum Set Value

Input Conf Digital Inputs Conf Linearization Table Conf

Input 1 Type **K Type Thermocouple**

Scale Minimum

Scale Maximum

Unit

Input offset

Coefficient of digital filter

Decimal Point

Minimum Set Value

Maximum Set Value

**Input 1 Type :**  
B, E, J, K, L, N, R, S, T, U, Pt100, NTC, 0-20mA, 4-20mA, 0-5V, 1-5V, 0-10V, 0-150mV, 0-550 , 0-10k

**Scale(Scale Min./Max.) :**  
Adjustable between -32768 ... 32767  
(Just for mA, V, mV, Ω, kΩ)

**Minimum Set Value :**  
Adjustable between Scale Minimum and Maximum Set Value.

**Maximum Set Value :**  
Adjustable between Scale Maximum and Minimum Set Value.

**Unit :**  
°C, °F, bar, %RH, Hz, mA, A, mV, V, Ohm, kOhm, %, g, kg, cm, m, m/s, m/min, km/h, cm3/s, m3/h, l/s, l/min, l/h pH, EC  
(Just for mA, V, mV, Ω, kΩ)

**Input offset :**  
Adjustable between -99 ... 99.

**Coefficient of digital filter :**  
1=200ms and it is device sampling time. Adjustable between 1 ... 32. Value of parameter should be increased in interference.

**Decimal Point :**  
According to range table , 1, 2 and 3 digit can be selected.

Input Conf Digital Inputs Conf Linearization Table Conf

Start - Stop Input: **Keypad**

Pause - Resume Input:

Previous Program Input:

Next Program Input:

**Digital Inputs :** Start/Stop , Pause/Resume , Next/Previous Program processes can be made by digital inputs or device keypad.  
If process will be performed only by Keypad , "Keypad" must be selected.  
If process will be performed only by Digital Input , "Digital Input" must be selected.  
If process will be performed both by Keypad and Digital Input , "Keypad and Digital Input" must be selected.

**Start/Stop :** Start-Stop Input and/or SET key.  
**Pause/Resume :** Pause-Resume Input and/or Back key.  
**Previous program :** Previous Program Input and/or Increase key.  
**Next program :** Next Program Input and/or Decrease key.

Input Conf Digital Inputs Conf Linearization Table Conf

Use Linearizasyon Table for 0-10 V

0.00	0.00	2.58	0.00	5.16	0.00	7.74	0.00
0.32	0.00	2.90	0.00	5.48	0.00	8.06	0.00
0.65	0.00	3.23	0.00	5.81	0.00	8.39	0.00
0.97	0.00	3.55	0.00	6.13	0.00	8.71	0.00
1.29	0.00	3.87	0.00	6.45	0.00	9.03	0.00
1.61	0.00	4.19	0.00	6.77	0.00	9.35	0.00
1.94	0.00	4.52	0.00	7.10	0.00	9.68	0.00
2.26	0.00	4.84	0.00	7.42	0.00	10.00	0.00

### Linearization Table Conf :

If input type is selected as mA, V, mV, Ω or kΩ, linearization can be done at 32 points.

Use Linearization Table for 0-10 V can be activated by pressing keys respectively.

Corresponding values of input signals must be entered to table in order to linearize at 32 points.

## Programming Outputs(Output Configuration Page)

**Output Type** : Relay, SSR, Motorized Valve, 0-20mA, 4-20mA or 0-10V. If relay is not selected for output type, relay can be configured as Alarm3 or motorized valve.

**Re-Transmission** : If output type is selected as relay or SSR, re-transmission can be selected as a 0/4-20mA or 0-10V. If output type is selected as a 0/4-20mA, re-transmission can be selected as a 0-10V.

If output type is selected as 0-10V, re-transmission can be selected as a 0/4-20mA.

**Maximum Analog Output Value** : % maximum analog output value.

**Minimum Analog Output Value** : % minimum analog output value.

**Output Hysteresis** : Adjustable between 0... 50. (If Proportional Band selected 0.0, ON-OFF control and output hysteresis will be active.)

**Output Power Offset Around Set Point** : Output power offset around SV according to error. In order to reach to SV fast.  

$$\text{TotalOutput}(\%) = \text{system output}(\%) + (100 / \text{Proportional Band}) * \text{error} * \text{OutputPowerOffset}/100.$$

**Control Configuration** : Selectable as Cool/Heat control. **The cooling control is only ON-OFF control (For Cooling control. Proportional Band must be 0.0).**

**Power Failure Behaviour** : If power failure occurs when profile control is running and device is powered on after power failure:  
 - If Stop is selected, profile control stops and turns to initial state.  
 - If Resume is selected, profile control resumes from where it is stopped.

**Output Power During Prob Failure(%)** : Adjustable between %0 ... %100. Output will continue in case of prob failure.

**Soft Start Time(sec)** : Adjustable between 0 ... 200 seconds.

If device is in profile control mode, programmed segments of profile control starts according to soft start time.

If device is in "Single Setpoint Mode", device starts to control according to soft start time after device is powered on.

**Consistently Control** : When profile control is finished; If OFF is selected, profile control stops and turns to initial state.

If ON is selected, profile control continues to control at last set value.

**SV Deviation** : End of the every profile control step, If difference between process value and set value is bigger than SV Deviation value ( SV - PV > SV Deviation ) then time countdown is paused and control remains at last set value until difference between process value and set value is smaller than SV Deviation value ( SV - PV < SV Deviation ). SV Deviation process can be enabled/disabled with ON/OFF option.

**Motorized Valve Position When Power On**: It provides to configuration of location of motorized valve when device power on.

**Motorized Valve On/Off Time (sn)**: It can configuration between 2-300 seconds

**Motorized Valve Control Period(%)**: Motorized valve configurations off time during on/off. This time gets by percent on/off time of motorized valve. If this time is less than 2 seconds, time will be 2 seconds automatically.

## Programming Alarms(Alarm Configuration Page)

**Alarm 1 Set Value** : Adjustable between Alarm 1 Up Limit and Alarm 1 Low Limit.

**Alarm 2 Set Value** : Adjustable between Alarm 2 Up Limit and Alarm 2 Low Limit.

**Alarm 3 Set Value** : Adjustable between Alarm 3 Up Limit and Alarm 3 Low Limit.  
 (In order to use Alarm 3, **Output Type** parameter must be different from **Relay** otherwise Alarm 3 will be unavailable and Alarm 3 Conf page will be hidden.)

**Alarm 1 Hysteresis** : Adjustable between 0 ... 50.

**Alarm 1 Type** : Independent alarm, Deviation alarm, Band alarm, Band Alarm with Inhibition or Profil control alarm can be selected. (In order to select Profile control segment alarms, Alarm 1 segments in Alarm Conf sub page of Profile Controller Configuration Page should be selected.)

**Alarm 1 Status** : For the Independent alarm, Band alarm or Band Alarm with Inhibition to be active below the set value LOW must be selected, to be active above the set value HIGH must be selected. If LOW is selected for Band alarm, alarm will be activated in band. If HIGH is selected, alarm will be activated out of band.

**Alarm 1 Status During Probe Failure** : For the alarm to be active in case of prob failure ON must be selected. For the alarm to be inactive in case of prob failure OFF must be selected.

**Alarm 1 Up Limit** : Adjustable between Scale Maximum and Alarm 1 Low Limit.

**Alarm 1 Low Limit** : Adjustable between Scale Minimum and Alarm 1 Up Limit.

**Alarm 2 "Alarm 2 Conf" and Alarm 3 "Alarm 3 Conf" are programmed in the same way.**

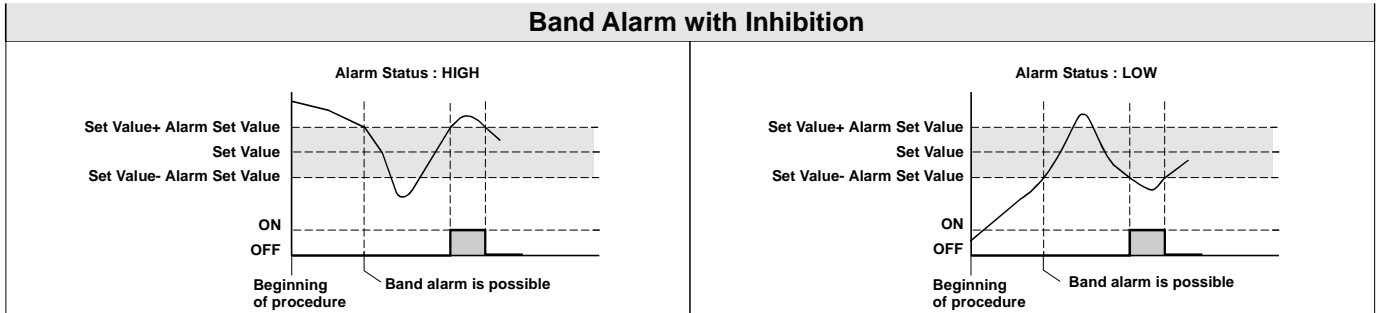
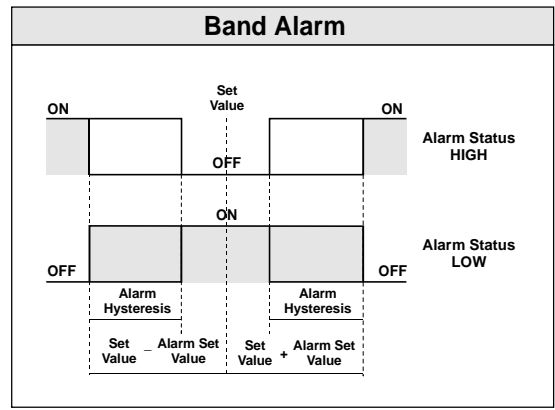
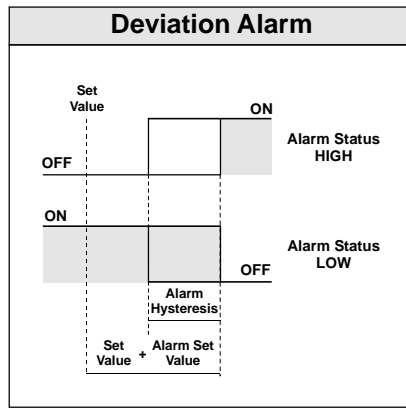
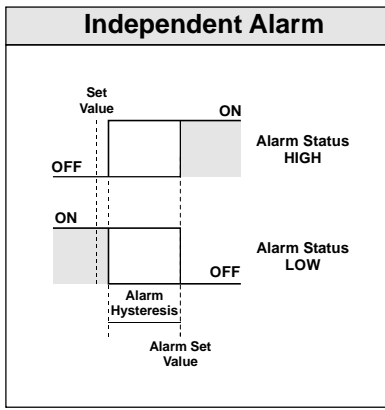

## Programming

PID Control Conf

Proportional Band (%)

Integral Time (min)

Derivative Time (min)

Control Period (sec)

Auto Tune  OFF  ON

### Programming PID Control (PID Control Configuration Page)

**Proportional Band (%)** : Adjustable between %0.0 ... %100.0.

If proportional band is selected 0.0 , ON-OFF control will be activated.

**Integral Time (min)** : Adjustable between 0.0 ... 100.0 minute.

**Derivate Time (min)** : Adjustable between 0.0 ... 25.0 minute.

**Control Period (sec)** : Adjustable between 0 ... 250 second.

**Auto Tune** : It allows to improve PID parameters after Self Tune. In normal operation, it provides the best control by automatically changing the PID parameters in case the measured value oscillates. If Auto Tune  ON is selected, it is active and the display shows AUTO TUNE RUNNING until Auto Tune is completed. Auto Tune  OFF must be selected to stop the Auto Tune operation.

#### PID Self Tune :

Self Tune is started by selecting  with   keys and pressing by  key. SELF TUNE IS

STARTED and SELF TUNE IS RUNNING messages is shown respectively.

If  key is pressed, SELF TUNE IS STOPPED message is shown and selftune is stopped and device turns back to home screen.

When Self Tune process is successful:

- SELF TUNE IS FINISHED, PRESS BACK TO EXIT message is shown and waits for user intervention in profile control mode.
- SELF TUNE IS FINISHED, SINGLE SETPOINT IS RUNNING message is shown and continues to control.

In order to start Selftune process PV must be smaller than %60 of SV , otherwise SELF TUNE IS STARTED and SELF TUNE IS STOPPED messages are shown respectively and home screen returned.

User must wait until PV drops under %60 of SV and start selftune again.

Modbus Conf

Modbus Communication  OFF  ON

Device Address

Baudrate

### Programming ModBus (Communication Configuration Page)

**Modbus Communication** : If parameter is selected ON modbus will be active , otherwise will be inactive.

**Device Address** : Adjustable between 1 ... 247

**Baudrate** : 4800, 9600, 19200, 38400 or 57600.

Security Code

Input Configuration Page Visibility

Output Configuration Page Visibility

Alarm Configuration Page Visibility

PID Control Configuration Page Visibility

Communication Configuration Page Visibility

Calibration Page Visibility

Profile Controller Configuration Page Visibility

Enter security code in order to change page visibilities.

### Programming Keypad Security Level(Security Configuration Page)

**Security Code** : In order to change security configuration , Security Code must be entered 123.

**Input Configuration Page Visibility** : Yes, No or None.

**Output Configuration Page Visibility** : Yes, No or None.

**Alarm Configuration Page Visibility** : Yes, No or None.

**PID Control Configuration Page Visibility** : Yes, No or None.

**Communication Configuration Page Visibility** : Yes, No or None.

**Calibration Page Visibility** : Yes or None.

**Profile Controller Configuration Page Visibility** : Yes, No or None.

No : Page can be opened , parameters can not be changed.

Yes : Page can be opened , parameters can be changed. None : Page can not be opened.



## Programming Profile Controller (Profile Controller Configuration Page)

**Program No** : Adjustable between 1 ... 16.  
**Start Program** : Adjustable 1 ... 16.  
**Single Setpoint** : If checkbox  is selected , single set point will be activated.(In this case profile controller is inactive)  
**Program Start Delay(min.)** : Adjustable between 0 ... 180.  
**Max. Step Count** : Adjustable between 1 ... 8.  
**Program Repeat Count** : Adjustable between 1 ... 8.  
**Next Program** : Adjustable between 0 ... 16. If 0 is selected , control will be stopped at end of the program.  
**Segment1/Time(min.)** : Adjustable between 0 ... 32000 min.  
**Segment1/Temp** : Adjustable between Minimum Set Value and Maximum Set Value parameters.

2, 3 ... 8. Segments are programmed in the same way.

**Segment1/Alarm1** : If checkbox  is selected , Alarm1 will be activated.  
**Segment1/Alarm2** : If checkbox  is selected , Alarm2 will be activated.  
 2, 3 ... 8. Segments are programmed in the same way.

If **Alarm Type** parameter is selected **profile control alarm** , Alarm1 and Alarm2 can be configured for the profile controller.

### Soft Start Conf :

1. **Segment Soft Start** : If checkbox  is selected , Soft Start will be activated.  
 Value of **Soft Start Time parameter** will be used as a selected segment's soft start time.  
 2, 3 ... 8. Segments are programmed in the same way.

### Graph Page :

Configuration can be seen from Graph Page.  
 - Program number,  
 - Set values of segments  
 - Segment counts  
 - Segment length

## MODBUS ERROR MESSAGES

Modbus protocol has two types error, communication error and operating error. Reason of the communication error is data corruption in transmission. Parity and CRC control should be done to prevent communication error. Receiver side checks parity and CRC of the data. If they are wrong, the message will be ignored. If format of the data is true but function doesn't perform for any reason, operating error occurs. Slave realizes error and sends error message. Most significant bit of function is changed '1' to indicate error in error message by slave. Error code is sent in data section. Master realizes error type via this message.

### ModBus Error Codes

Error Code	Name	Meaning
01	ILLEGAL FUNCTION	The function code received in the query is not an allowable action for the slave. If a Poll Program Complete command was issued, this code indicates that no program function preceded it.
02	ILLEGAL DATA ADDRESS	The data address received in the query is not an allowable address for the slave.
03	ILLEGAL DATA VALUE	A value contained in the query data field is not an allowable value for the slave.

### Message example;

#### Structure of command message (Byte Format)

Device Address	(0A)h
Function Code	(01)h
Beginning address of coils.	MSB (04)h
	LSB (A1)h
Number of coils (N)	MSB (00)h
	LSB (01)h
CRC DATA	LSB (AC)h
	MSB (63)h

#### Structure of response message (Byte Format)

Device Address	(0A)h
Function Code	(81)h
Error Code	(02)h
CRC DATA	LSB (B0)h
	MSB (53)h