

Index

1-0 General Description

2-0. Input Requirements Specification

3-0. Output Requirements Specification

4-0. Reliability Specification

5-0. Environment Specification

6-0. Safety Specification

7-0. Mechanical Specification

1-0. General Description

The purpose of the document is to specify a **Single phase AC input, single output** switching power supply. This specification is suitable for: EA10931F

This product is AC to DC switching power transfer device, it can provide for a 24Vdc, 3.75A max., 90W Max. DC output with constant voltage source.

This Specification defines the input, output, performance characteristics, environment, noise and safety requirement for a power supply.

2-0. Input Requirements

2-1. AC Input Voltage

Maximum Voltage : 264Vac

Normal Voltage : 100~240Vac

Minimum Voltage : 90Vac

2-2. AC Input Frequency

Maximum Frequency : 63Hz

Normal Frequency : 50~60Hz

Minimum Frequency : 47Hz

2-3. Input Current:

1.5A (Max.) @ 100Vac/60Hz-240Vac/50Hz will Max. load.

2-4. Efficiency:

Designed to meet the following standard :

2-4-1. Efficiency :

89% (Avg.) at 115Vac/60Hz & 230Vac/50Hz input voltage and 25%、 50%、 75% & 100% of Max. output current.

79% at 115Vac/60Hz & 230Vac/50Hz input voltage and 10% of Max. output Current.

2-4-2.No Load Power Consumption : No Load Watt < 0.15W at normal line input.

2-5. Configuration

3-wire AC input (**Line ,Neutral ,FG**)

2-6. Input Fuse

The hot line side of the input shall have a fuse, rating (**T3.15A/250V**)

2-7. Inrush Current:

60A at 110Vac At cold start, Max. load.

120A at Vac At cold start, Max. load.

2-8. Line Regulation:

This line regulation is less than $\pm 1\%$, 100Vac/60Hz-240Vac/50Hz, with Max. load.

2-9. Hold Up Time:

10mSec. @ 100Vac/60Hz-240Vac/50Hz, with Max. load.

2-10. Rise Time:

50mSec. @ 100Vac/60Hz-240Vac/50Hz, with Max. load.

From 10% to 90% of output voltage.

2-11. Turn-ON Time:

The output voltage should rise to 90% of rated output voltage.

in less than **3 SEC.** 100Vac/60Hz-240Vac/50Hz, with Max. load.

2-12. Harmonic Standard and Power Factor

The adaptor complied with IEC61000-3-2 Class D harmonic standard while input power over than 75W. The PF shall > 0.95 @ 100Vac input and > 0.9 @ 240Vac input with Max. load.

3-0. Output Requirements

3-1. Output Voltage and Current

Output Voltage (Vdc)	Current Min. (A)	Current Max. (A)
+24V	0A	3.75A

3-2. Combine Regulation

Output Voltage (Vdc)	Tolerance (%)	Regulation (V)
+ 24V	+5%~-5%	22.8V ~ 25.2V

3-3. Dynamic Load Regulation

$\pm 5\%$ excursion for 50% - 100% or 100% - 50% load change of DC output at any frequency up to 1KHz(duty 50%)

3-4. Ripple & Noise

The power supply shall not exceed the following limits on the indicated voltage for 60Hz or 50Hz ripple,

Switching frequency ripple and noise and dynamic load variations measured with a 20MHz

bandwidth.

Output	Ripple/Noise
+24V	1.5% max. of full load & 50% load current

Ripple / Noise : 60Hz ripple + switching ripple and noise.

Ripple & Noise are measured at the end of output cable which are added a 0.1uF ceramic capacitor and a 47uF electrolytic capacitor.

3-7. Over Voltage Protection

150% Max. of the rated output voltage.

The adaptor shall have OVP with auto-recovery mode when output voltage reaches the trigger point of OVP.

3-8. Short-Circuit Protection

The adapter can withstand continuous short at DC output and no damage. It will enter into Normal condition if the fault condition is removed. The short circuit impedance should be less than 0.3R.

3-9. Over Current Protection

110 ~ 150% of rated output current.

The adapter can withstand continuous short at DC output and no damage.

It will enter into normal condition if the fault condition is removed.

3-10. Stability

2% Max. at constant load with constant input (after 30 minutes of operation).

3-11. Drop-out (Power Line Disturbance)

Output voltage shall remain within the specified regulation range, through the absence of a line input during 1/2 cycle, at full load and normal AC line input.

3-12. Voltage Isolation

The DC ground will be isolated from the AC neutral and AC line.

4-0. Reliability.

4-1. MTBF: (MIL-HDBK-217F)

The power supply shall be designed and produced to have a mean time between failure (MTBF) of 100,000 hours at 25 .

5-0. Environment.

5-1 Temperature :

- a. Operating : 0 to 40
- b. Storage : -20 to 85

5-2 Humidity :

- a. Operating : 10 to 90 %
- b. Storage: 5 to 90 %

5-3 Altitude :

From sea level to 5,000 Meter (operation) and 5,000 Meters (non operation)

6-0. Safety

6-1. Hi-Pot Test

AC 3000V 10mA 60 Sec. between primary and secondary circuit.
AC 1800V 10mA 2 Sec. between L & N and FG.

6-2. Insulation Test

500Vdc 3sec. between primary and secondary circuit.
IR should 50M

6-3. Leakage Current

750uA, at 240Vac/50Hz.

6-4. Safety

UL, CUL, TUV, CB, CE, FCC, BSMI, CCC

6-5. EMS

Items	Specification	Reference
ESD	Contact : $\pm 4KV$	IEC61000-4-2
	Air : $\pm 8KV$	
RS	Frequency : 80 ~ 1000MHz Field Strength 3V/M , 80% AM(1KHz)	IEC61000-4-3
EFT	1.0KV on input AC power ports.	IEC61000-4-4
SURGE	Line to Line : $\pm 1KV$ (peak)	IEC61000-4-5
	Line to FG : $\pm 2KV$ (peak)	

6-6. EMI

Comply with Standards
CISPR32, EN55032 Class B
FCC PART 15 Class B

7-0. Mechanical Characteristics.

7-1. Physical Size: 134.5mm (L) * 58.8mm (W) * 25.4mm (H)

7-2. Enclosure material: 94V-0 minimum.

7-3. Output Cable (Reference) : UL1185 # 18

7-4. Vibration Test

The vibration frequencies are set at 20Hz, with total amplitude of 1.5mm along the 3 directions namely X-Y-Z. The each direction should be vibrated for 60 minutes, after testing no abnormal electrical or mechanical should occur.

7-5. Drop Test (Referencing to CSA C22.2 No.950/UL1950/UL1310/EN62368)

Products shall be dropped from a height of 1000 mm onto a horizontal surface consists of hardwood at 13mm thick, mounted on two layers of plywood each 19mm to 20mm thick, all supported on a concrete or equivalent non-resilient floor. Upon conclusion of test , the equipment don't need be operational , but need meet Hi-Pot specification requirement .

7-6. Net Weight (Reference) : 350g

EDAC EDACPOWER ELEC.

AC ADAPTER 电源适配器 电源供应器

MODEL 型号 型号 :EA10931F-240

AC INPUT 输入 输入 :100-240Vac, 2.5A, 50-60Hz

DC OUTPUT 输出 输出 :24.0V==3.75A 90.0W



CAUTION 注意 注意

FOR INDOOR USE ONLY 室内产品使用 室内产品使用
I.T.E. USE ONLY

I.T.E. POWER SUPPLY
41TJ
E209833 LPS



R33147
RoHS



DATE CODE:

出厂日期 出厂日期

20	21	22			1	2	3	4	5
1	2	3	4	5	6	7	8	9	0



制造商: 翌胜电子股份有限公司

13128

C1 C3

MADE IN CHINA 中国制造 中国製造



R2*3

42.3

3

74.3

EDAC P/N.: 3128

Background: Black color

Character: Silver color

Unit: mm

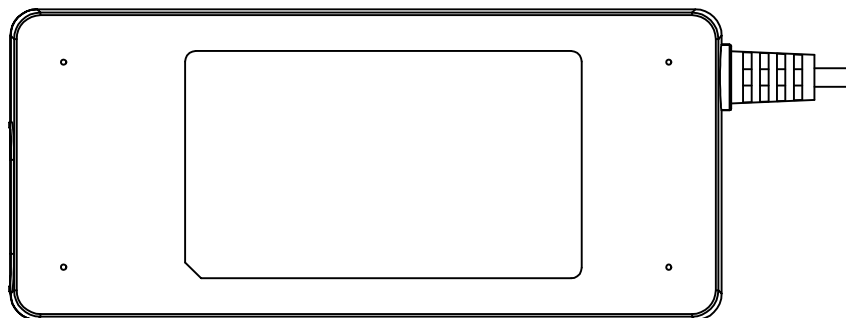
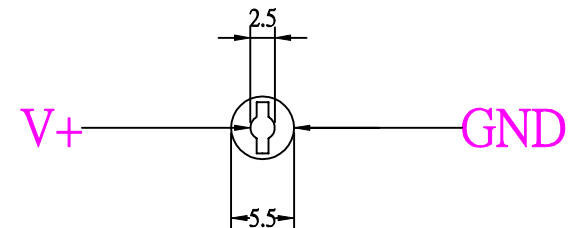
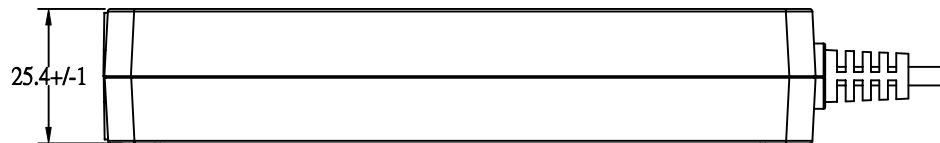
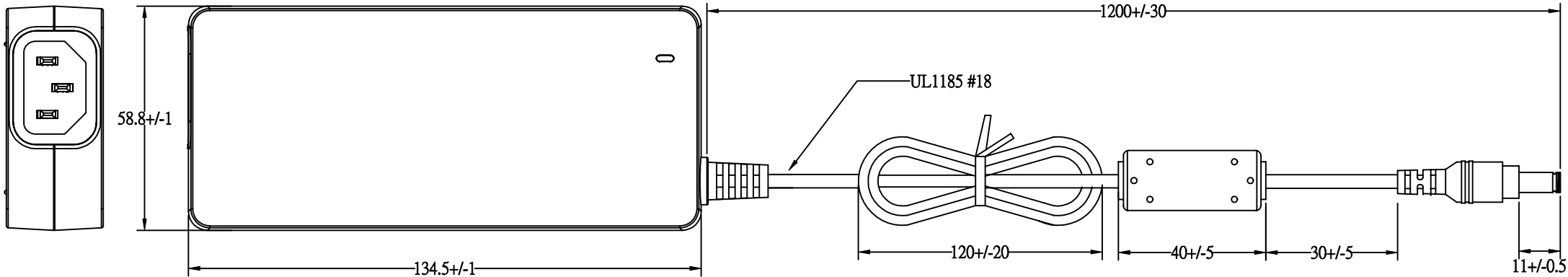

EDAC POWER ELEC.				APPROVED
MODEL	EA10931F(T01)	UNIT	mm	DESIGNED
color	BLACK	SCALE		CHECK
cus.		DATE	2020-05-27	DRAWING L.J.YU