

MOTO TIMER RATTLE-OF

Vibration activated engine hour meter. Needs strong vibration



Application:

- Vibration activated (needs a strong vibration)
- For motor-operated engines and garden tools with a strong vibration

Connectivity:

- Attachment on vibrating surfaces

Function:

- Total engine hours not resettable
- Indication range: 0,1 – 99.999h
- Resolution: 1/10h = 6min.
- Event counter: Shows how often the meter was activated. (Press button approx. 6 sec.)
- **This engine hour meter needs a strong vibration**

Technical data:

Dimensions:	56mm x 35,5mm x 16mm
Weight:	27g
Housing:	Plastic, shock-proof and impact-resistant
Display:	LCD-Display 12,7mm x 24,5mm Digit height 6mm
Accuracy:	+/-0,01% @ 25°C
Temperature range:	-40°C - +52°C
Power supply:	Internal lithium battery Battery life >8 years Internals 100% encapsulated
Certificates:	RoHS, CE, WEE, REACH
Article number:	MT-002-OF

Fig. 1

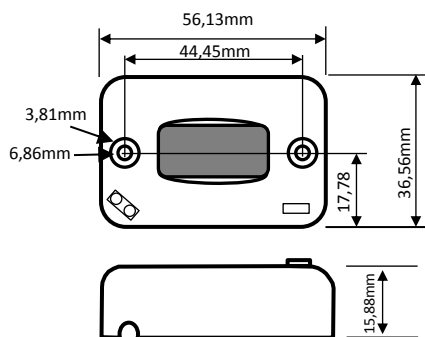
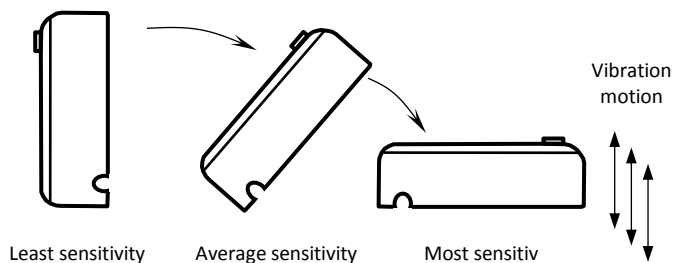

Fig. 2



Installation and Operation:

Find a convenient mounting location per desired sensitivity in Figure 2. Note that Figure 2 is a guideline, and that some experimentation maybe required to determine the optimum mounting position.

Mount the meter with screws or double sided tape. If using screws, use the meter to make a template for drilling holes.

Enabling Meter: As received, the meter will display the model code until enabled. To enable meter, press and hold the button for approximately 6 seconds, until the display shows "0000.0".

Never drill into gas tanks, engine crankcase or other hazardous material containers! Contact a qualified dealer if in doubt. Always wear safety glasses while installing. The mounting area should not exceed 65°C.

This engine hour meter is not a toy! Keep away from children.