

VOLTCRAFT

VOLTCRAFT - RELIABLE AND PRECISE. SINCE 1982.

For decades, our product range has been dynamically adapting to the constant changes in the industry.

We commit to offering first-class quality to our customers while delivering an excellent cost-performance ratio. This philosophy remains the cornerstone of Voltcraft's success.

LITHIUM BATTERY 1600 MAH



TECHNICAL DATA

Item No.:	2526461	3451150
Packaging	1 pc/set	10 pcs/set
Type	Lithium 2/3 AA	
Classification	Non-rechargeable	
Nominal voltage	3.6 V	
Capacity	1600 mAh	
Max. discharge current	35 mA (Continuity) 60 mA (Plus)	
Termination voltage	2.0 V	
CCV @330Ω	3.3 V	
Operation conditions	-40 to +85 °C, ≤65% RH	
Storage conditions	10 to +25 °C, ≤65% RH	
Dimensions (H x Ø)	33.5 x 14.5 mm	
Weight (approx.)	13 g per pc	

*For performance and safety, observe the operating / storage conditions.

DIMENSIONS AND WEIGHT

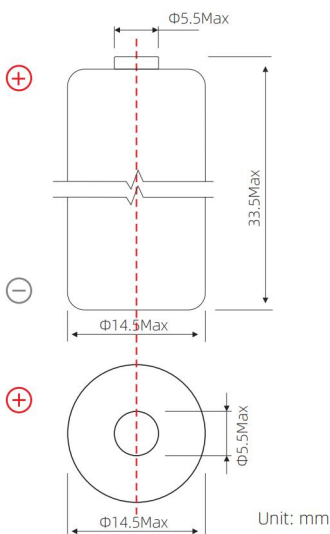

PERFORMANCE CHARACTERISTICS

Discharge characteristics

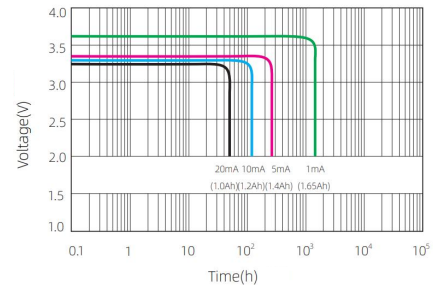

Voltcraft VS temperature

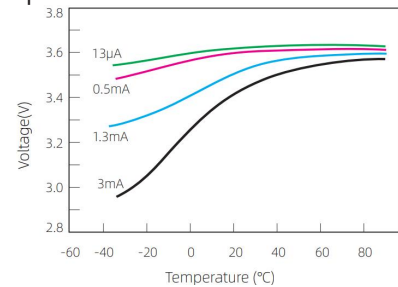

Capacity VS current

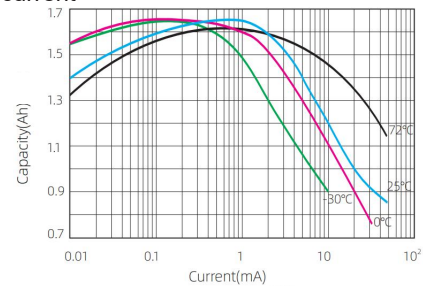

Storage characteristics

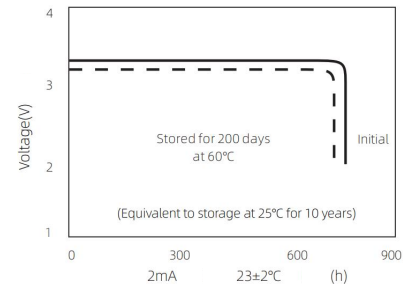

This is a publication by Conrad Electronic SE, Klaus-Conrad-Str. 1, D-92242 Hirschau (www.conrad.com). All rights including translation reserved. Reproduction by any method, e.g. photocopy, microfilming, or the capture in electronic data processing systems require the prior written approval by the editor. Reprinting, also in part, is prohibited. This publication represents the technical status at the time of printing.

Copyright 2026 by Conrad Electronic SE.*2526461_3451150_V1_0326_02_dm_ds_en