



EN/CN/DE/FR/한-A01

Adventurer 4 Series / 冒险家4 系列

Quick Start Guide

≡ 快速启动指南 ≡

EN P01 / CN P07 / DE P13 / FR P19 / 한 P25

⚠ WARNING
注意事项

1. Do not remove the wrapping around the nozzle.
 2. Hot! Avoid touching the heating nozzle in operation.
 3. Moving parts in printer may cause injury. Do not wear gloves or other sources of entanglement in operation.
1. 切勿去除包裹在喷嘴处的耐高温材料。
2. 高温危险！打印机喷嘴在工作时会被加热，操作时请避免接触！
3. 可动部件可能会造成卷入挤压和切割伤害。操作机器时请不要配带手套或缠绕物。

This guide is only applicable to FLASHFORGE Adventurer 4 Series 3D printer

本手册仅适用于闪铸科技 冒险家4 系列 3D打印机

Adventurer 4 Series Quick Start Guide

Component Introduction

1. Power switch
2. Power socket
3. Filament cover
4. Spool holder
5. Filament intake cover
6. Front cover
7. Platform base
8. Build plate
9. Touch screen
10. USB
11. Ethernet input

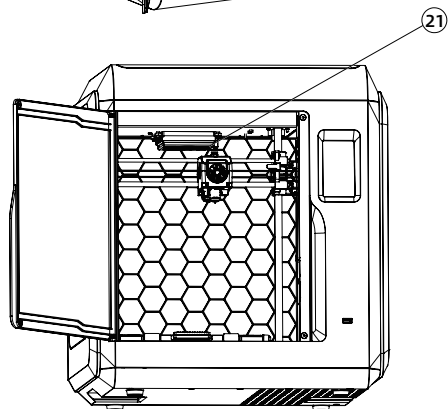
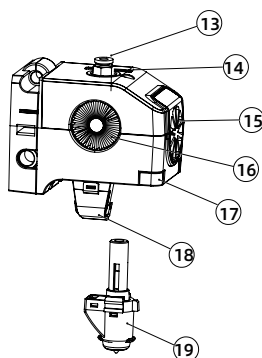
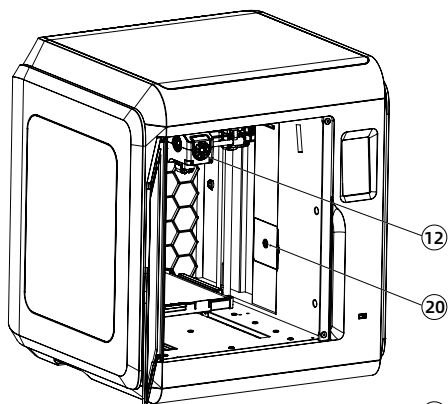
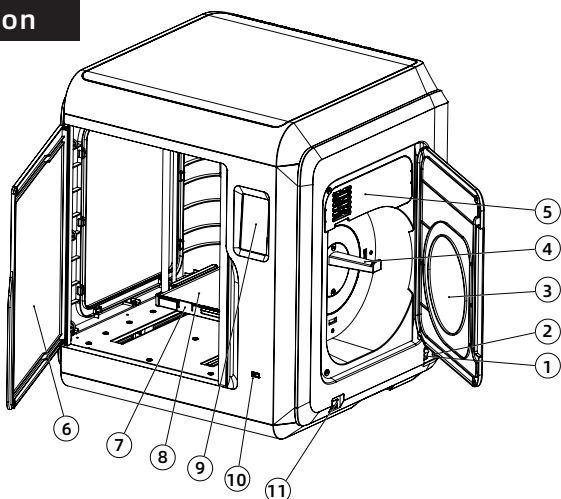

12. Extruder
13. Filament guide tube joint
14. Cable slot
15. Fan for cooling model
16. Fan for cooling extruder
17. Buckle
18. Air duct
19. Nozzle
20. Camera(AD4)
21. Air filter(AD4)

Adventurer 4 lite features a glass platform with no camera and no air filter.

Packing Specification

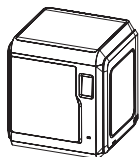

3D Printer



Filament



Power Cable



After-Sales
Service Card



Quick Start Guide

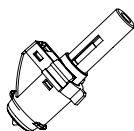

0.4-265 Nozzle
(AD4 Equipped)



Screwdriver

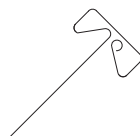

Unclogging
Pin Tool



Allen Wrench

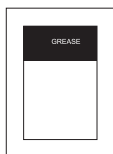

Grease

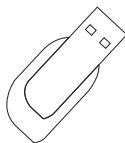

USB Disk
(AD4 Equipped)

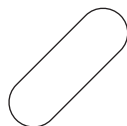

Leveling Card

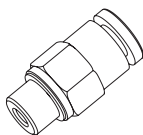

Filament Guide
Tube Joint

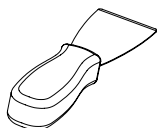

Scraper
(AD4 Lite Equipped)



Glue
(AD4 Lite Equipped)

Software Installation

Find the FlashPrint installation package in the USB disk and select the version corresponding to your system to install.

Or you can download it from <https://www.flashforge.com/download-center>.

Preparation of Device

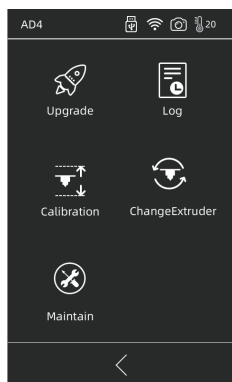

The equipment has been leveled and calibrated before delivery, but due to transportation or other influences, the distance between nozzle and platform may change. It is recommended to conduct [Calibration] after unpacking.

This step is optional, please refer to the interface function introduction before operation.

Print

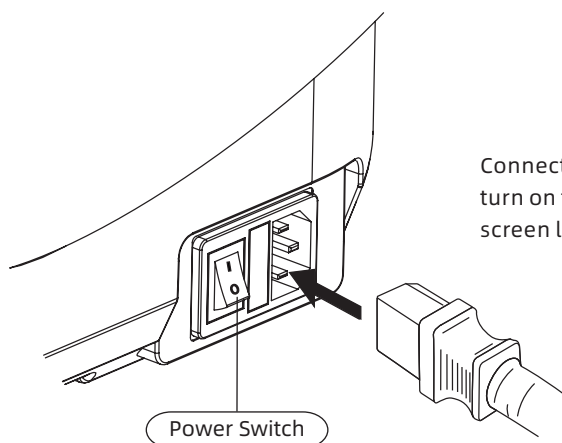

Connect cable to printer;
turn on the switch, the
screen lights up.

1.Connect to power.

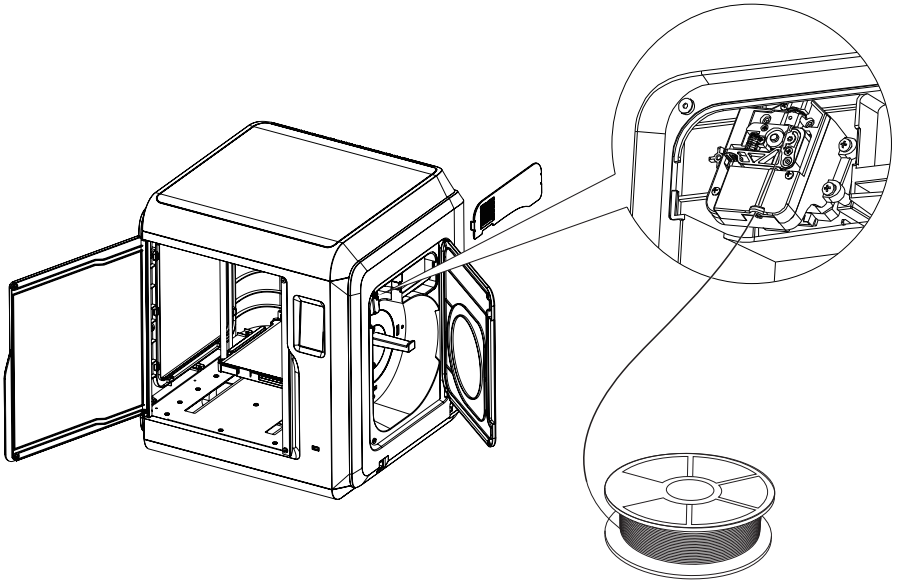

2. Load Filament: open the filament cover on the right side, insert the filament into the filament intake, push filament into the feeding wheel until some resistance is felt. Please make sure filaments are in the feeding wheel. Tap [Prepare]-[Filament]-[Load]. Follow the instruction, filament coming out of the nozzle indicates a success.

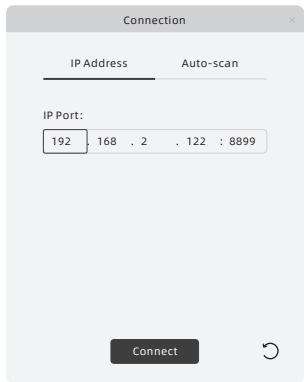
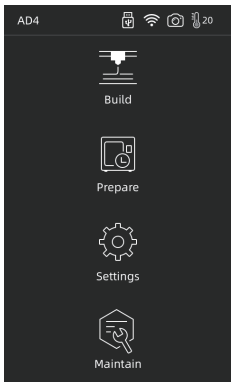

Note

When the user wants to use the browser to view images, the printer and PC must be in an intranet (that is, the printer and PC connect to the same router).

3. Model File Transfer

Method 1: Wi-Fi Connection

Tap [Settings]-[Network]-[WIFI], operate according to the instruction. Open FlashPrint, click [Print], then click [Machine Type], select [FlashForge Adventurer 4 / 4 Lite]. You can try to enter the IP address or scan it automatically. The IP address can be viewed in [settings] - [about].

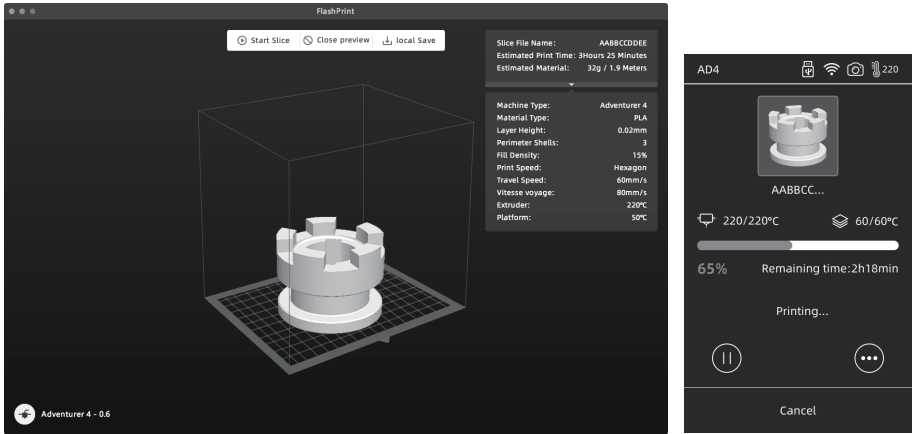

Import stl or obj file into the slicer; after slicing, the printer will heat up and start printing automatically.

Method 2: USB Device

Files can be read in USB disk. Insert USB disk and select the files to print.

4. Model Removal

Adventurer 4: Take out the removable build plate, and bend the plate to get the model

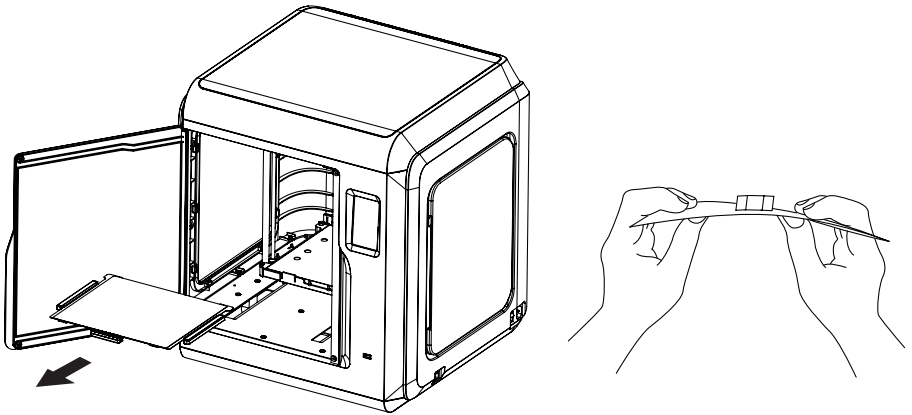

Adventurer 4 Lite : Use the Scraper to take out the model

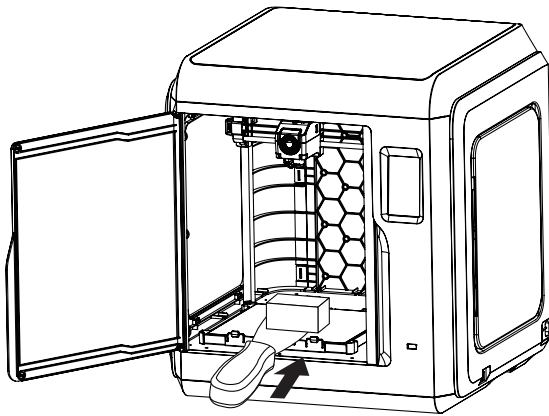

⚠ Note

Nozzle and build plate are still hot after finishing printing, please wait for them to cool down before you operate.

It is recommended to take the plate to the outside of the equipment for model removal, otherwise the model debris will remain in the equipment. Please keep the inside of the printer clean.

冒险家4 快速启动指南

整机介绍

1. 电源开关
2. 电源插座
3. 丝盘门
4. 料盘架
5. 送丝盖板
6. 前门
7. 平台底座
8. 平台板
9. 触控屏
10. USB
11. 网口

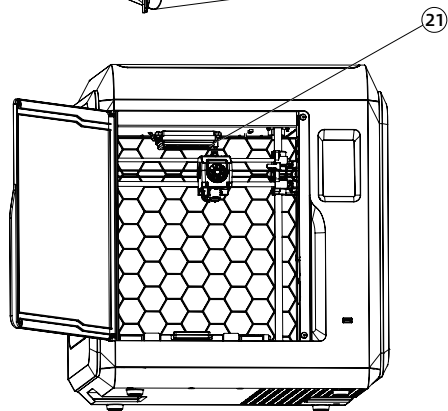
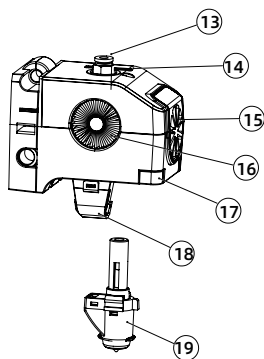
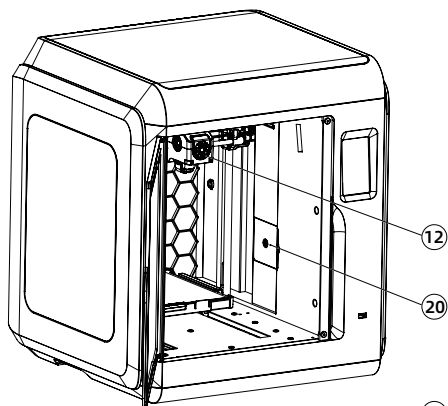
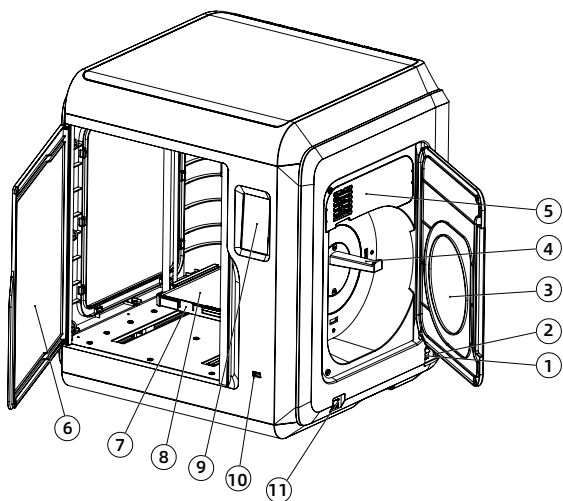

- | | |
|---------------|----------------|
| 12. 喷头 | 13. 气管接头 |
| 14. 排线槽 | 15. 模型冷却风扇 |
| 16. 喷头冷却风扇 | 17. 卡扣 |
| 18. 导风嘴 | 19. 喷嘴 |
| 20. 摄像头 (AD4) | 21. 空气过滤 (AD4) |

Adventurer 4 lite 为玻璃平台，无摄像头，无空气过滤。

装箱清单

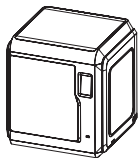

3D打印机



3D打印耗材



电源线



售后服务卡



快速启动指南

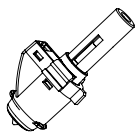

0.4-265喷嘴
(AD4 配置)



十字螺丝刀

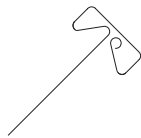

通针



内六角扳手

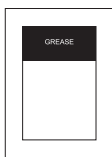

润滑脂

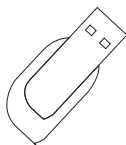

U盘 (AD4 配置)

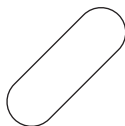

调平卡

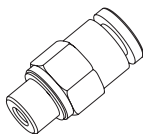

气管接头

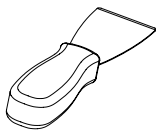

铲刀 (AD4 Lite 配备)



胶水 (AD4 Lite 配备)

软件安装

方法一：在U盘中找到FlashPrint软件安装包，选择对应的系统版本进行安装。

方法二：从官方网站 www.sz3dp.com 下载最新的切片软件。

注：官网可下载到最新的切片软件。

设备预准备



设备出厂经过调平校准，但由于运输等情况，喷嘴与平台间距可能发生变化，建议在开箱后进行一次【喷头校准】。

此步骤非完全必要操作。具体操作根据界面指引。

首次打印

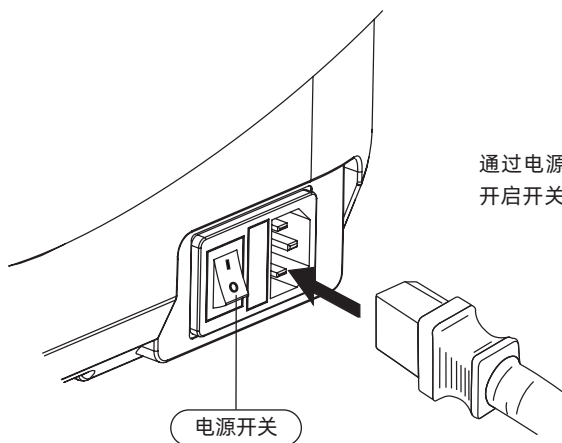

通过电源线连接电源与打印机；
开启开关，屏幕点亮。

1. 连接电源。

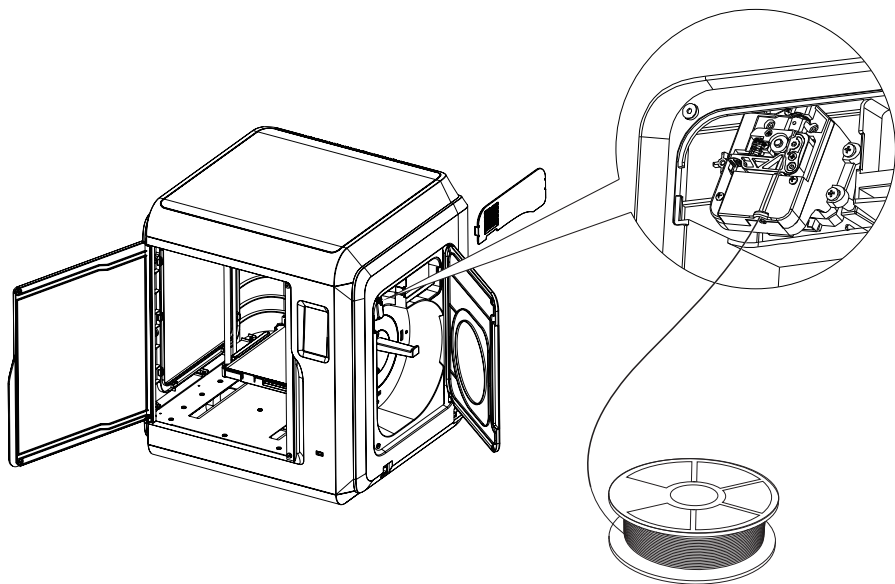

2.安装丝料：打开右侧耗材门，将丝料插入进丝口，推入送丝轮内，感受到一定阻力即可。请务必确认丝料已经推入送丝轮。点击屏幕准备-丝料-进丝。按屏幕指示操作，待喷嘴吐出丝料说明进丝完成。



⚠️ 注意事项

打印机连接的网络和电脑连接的网络必须在同一网段中，否则无法连接成功。

3.传输文件

方式一：传输WiFi

点击设备的设置-网络-WiFi，按屏幕提示连接即可；打开FlashPrint，点击菜单中的打印按钮，选择冒险家4/4 Lite连接机器；可通过输入IP地址或自动扫描的方式，IP地址可在设备设置-关于中查看。

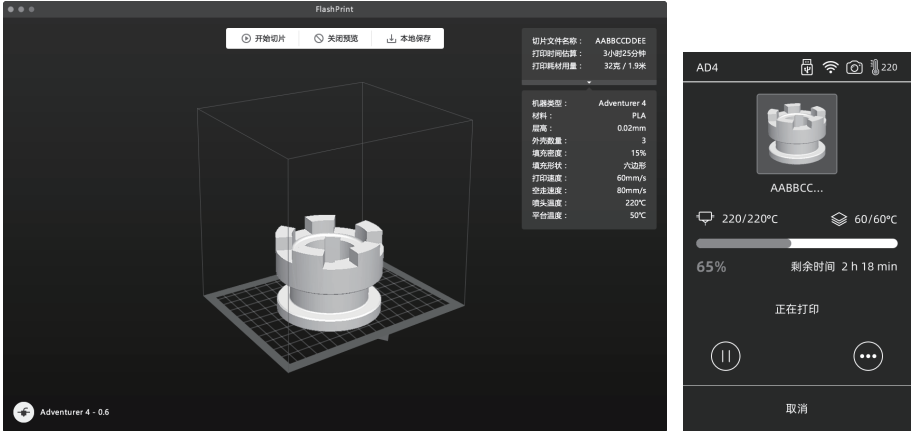

将stl或obj文件导入到切片软件中；进行切片，软件切片完成后，打印机进行加温等工作，准备完成后自动开始打印。

方式二：U盘打印

设备也可通过U盘打印，将切片好的文件保存至U盘，将U盘插入到设备，选择对应文件点击打印。

4.打印后模型移除

直接取出平台柔性钢板，折弯平台即可取下模型。

4.打印后模型移除

冒险家4: 直接取出平台柔性钢板, 折弯平台即可取下模型

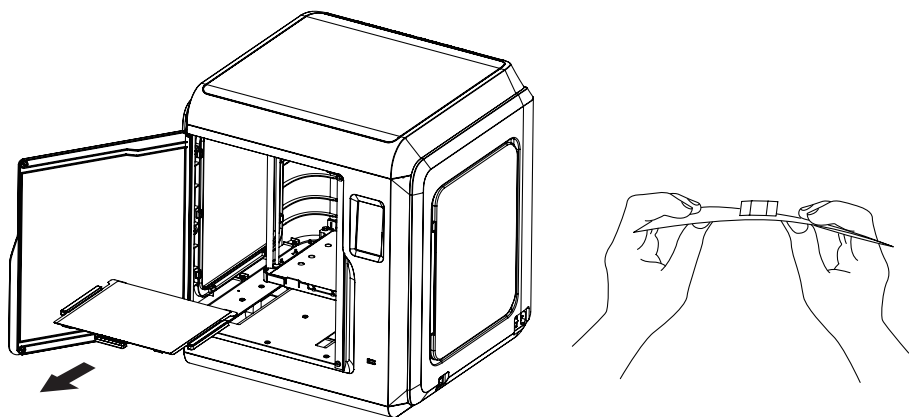

冒险家4 Lite : 使用铲刀移除模型

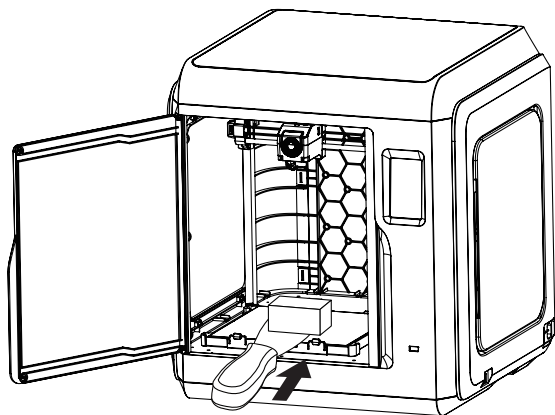

⚠ 注意事项

打印完成时, 喷嘴和打印平台仍处于高温状态, 建议冷却后操作。

模型移除建议将平台板拿到设备外部再进行移除, 否则模型碎屑容易留在设备腔体内, 建议保持腔体清洁。

Adventurer 4 Kurzanleitung

Vorstellung der Komponenten

1. Netzschalter
2. Steckdose
3. Filamentabdeckung
4. Spulhalter
5. Filamenteinzugsabdeckung
6. Frontblende
7. Plattformsokkel
8. Konstruktionsplattform
9. Touchscreen
10. USB
11. Ethernet-Eingang

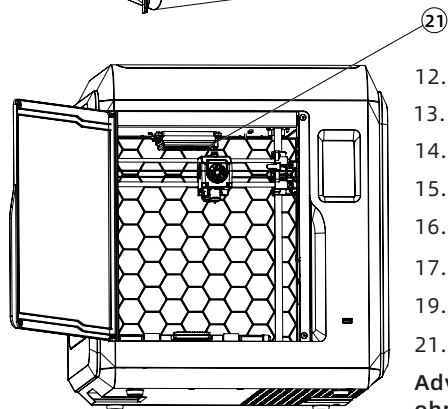
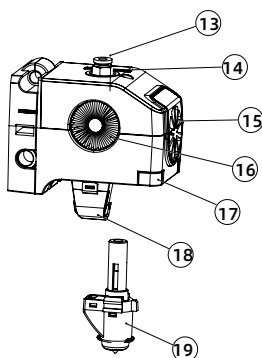
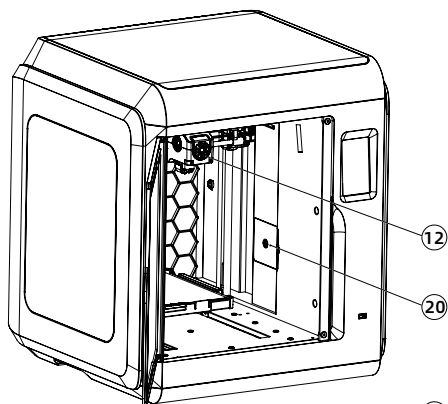
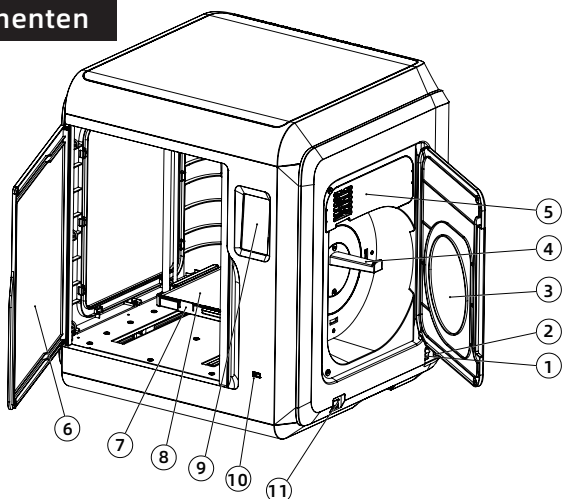

12. Extruder
13. Filamentführung-Rohrverbindung
14. Kabelschlitz Gebläse für die Modellkühlung
15. Gebläse für die Modellkühlung
16. Gebläse für die Extruderkühlung
17. Spange Luftkanal
18. Luftkanal
19. Düse
20. Kamera(AD4)
21. Luftfilter(AD4)

Adventurer 4 lite ist eine Glasplattform ohne Kamera und ohne Luftfilter.

Verpackung

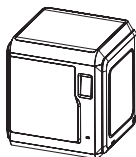

3D-Drucker



Filament



Stromkabel



Kundendienstkarte



Kurzanleitung

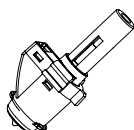

Düse 0,4-265
(AD4 Ausstattung)



Schraubendreher

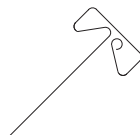

Reinigungstiftwerkzeug



Innensechskantschlüssel

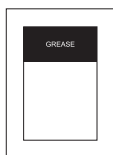

Fett

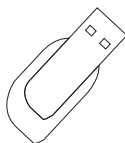

USB-Festplatte
(AD4 Ausstattung)

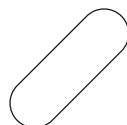

Nivellierkarte

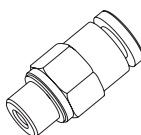

Filamentführung-Rohrverbindung

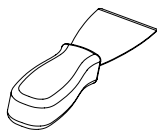

Abstreifer (AD4 Lite Ausstattung)



Leim (AD4 Lite Ausstattung)

Software-Installation

Suchen Sie das FlashPrint-Installationspaket auf dem USB-Wechseldatenträger und wählen Sie für die Installation die entsprechende Version für Ihr System.

Sie können das Paket auch hier herunterladen:

<https://www.flashforge.com/download-center>.

Vorbereitung des Gerätes

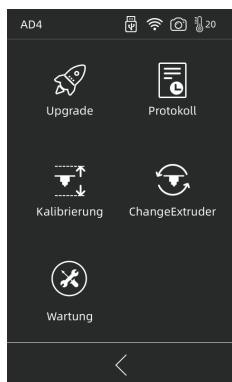

Das Gerät wurde vor der Auslieferung nivelliert und kalibriert, allerdings kann sich die Distanz zwischen, Düse und Plattform infolge von Transport- oder anderen Einflüssen verändern. Es wird empfohlen, dass Sie nach dem Auspacken eine [Kalibrierung] durchführen.

Es handelt sich um eine optionalen Schritt; weitere Informationen entnehmen Sie bitte der Beschreibung für die entsprechende Funktion.

Drucken

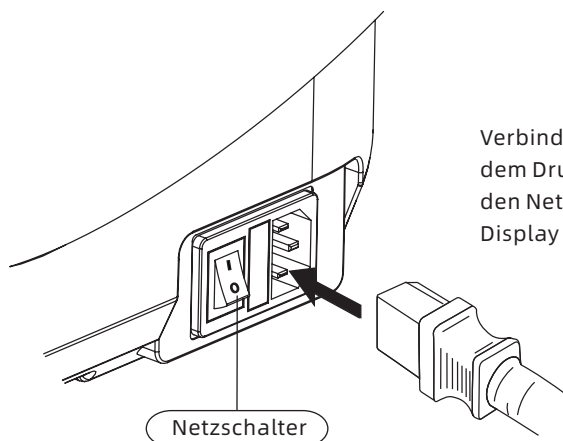

Verbinden Sie das Kabel mit dem Druck, betätigen Sie den Netzschalter. Das Display leuchtet auf.

1. Mit der Stromversorgung verbinden.

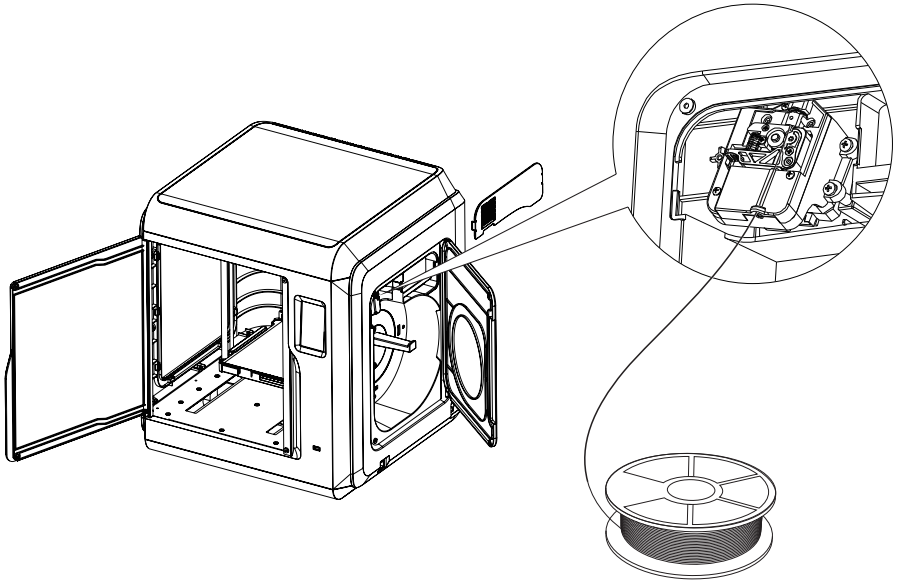

2. Filament laden: Öffnen Sie die Filamentabdeckung auf der rechten Seite, führen Sie das Filament in die Aufnahme ein. Drücken Sie das Filament in das Zuführrad, bis Sie Widerstand spüren. Die Filamente müssen in das Zuführrad eingelegt sein. Berühren Sie [Vorbereiten]-[Strang]-[Laden]. Befolgen Sie die Anweisungen. Sobald Filament aus der Düse austritt, ist der Vorgang erfolgreich abgeschlossen.

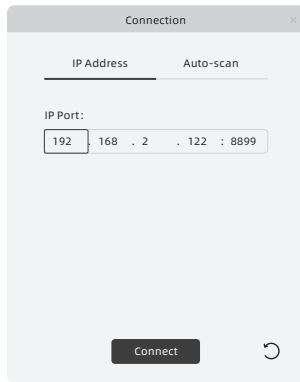
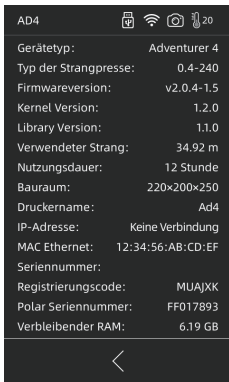

Hinweis

Für die Ansicht der Bilder im Browser müssen Drucker und PC mit dem Internet verbunden sein (d. h., Drucker und PC sind mit demselben Router verbunden).

3.Übertragung der Modelldatei

Methode 1: WLAN-Verbindung

Berühren Sie [Einstellungen]-[Netzwerk]-[WIFI] und befolgen Sie die Anweisungen. Öffnen FlashPrint. Tippen Sie auf [Drucken] > [Gerätetyp] und auf [Flashforge Adventurer 4 / 4 Lite]. Sie können auch die IP-Adresse eingeben oder automatisch nach dem Gerät suchen (Scan). Die IP-Adresse finden Sie unter [Einstellungen] - [Über].

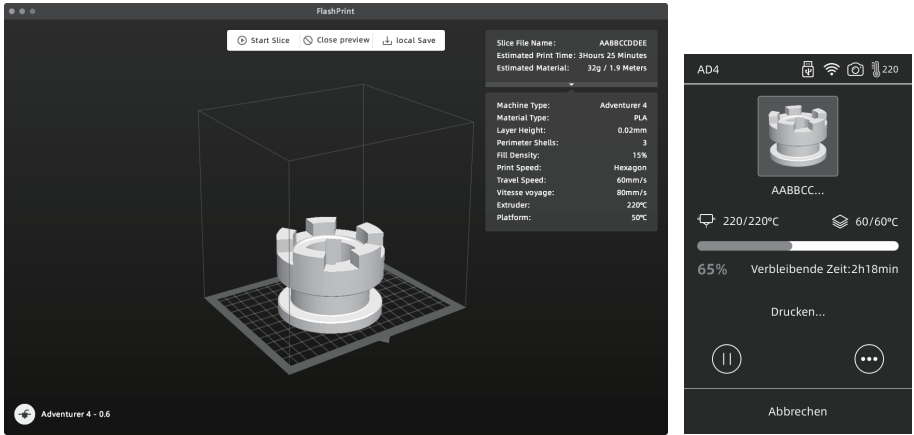

Importieren Sie die stl- oder obj-Datei in den Slicer. Nach dem Slicen erfolgt der Aufwärmvorgang. Dann startet der Druckvorgang automatisch.

Methode 2: USB-Gerät

Die Dateien können vom USB-Wechseldatenträger eingelesen werden. Verbinden Sie den USB-Wechseldatenträger und wählen Sie die Dateien für den Druck aus.

4. Modell herausnehmen

Adventurer 4: Nehmen Sie die Bauplatte heraus und biegen Sie die Platte, um das Modell zu lösen

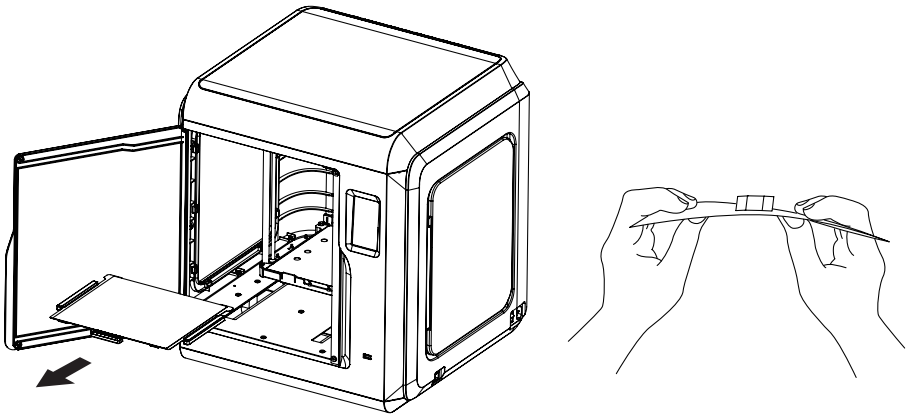

Adventurer 4 Lite: Verwenden des Werkzeugs zum Entfernen des Modells

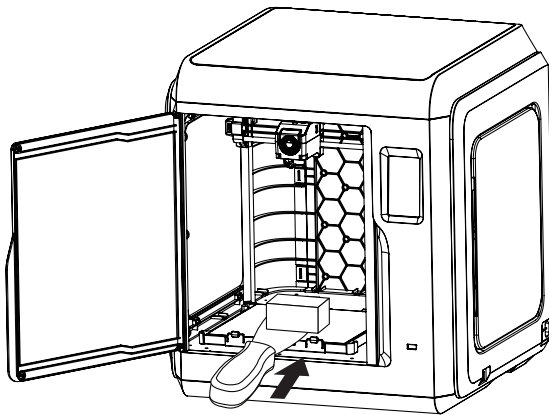

⚠ Hinweis

Nach dem Druckvorgang sind Düse und Konstruktionsplatte noch heiß. Warten Sie bitte, bis beide abgekühlt sind, bevor Sie fortfahren.

Es wird empfohlen, die Platte aus dem Gerät nehmen, um das Modell zu lösen. Sonst bleiben Rückstände des Modells im Gerät zurück. Das Innere des Druckers muss stets sauber sein.

Adventurer 4 Guide rapide

Présentation des composants

1. Interrupteur
2. Prise de courant
3. Couvercle de filament
4. Support de bobine
5. Couvercle de l'entrée de filament
6. Couvercle avant
7. Support du plateau
8. Plateau
9. Ecran tactile
10. USB
11. Entrée Ethernet

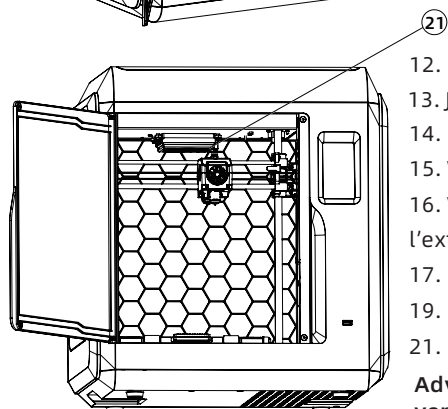
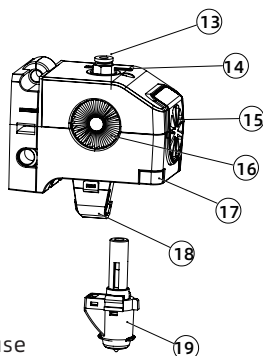
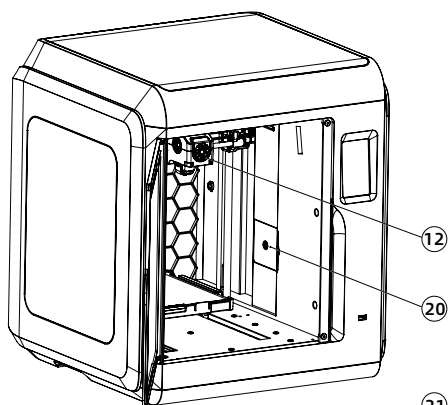
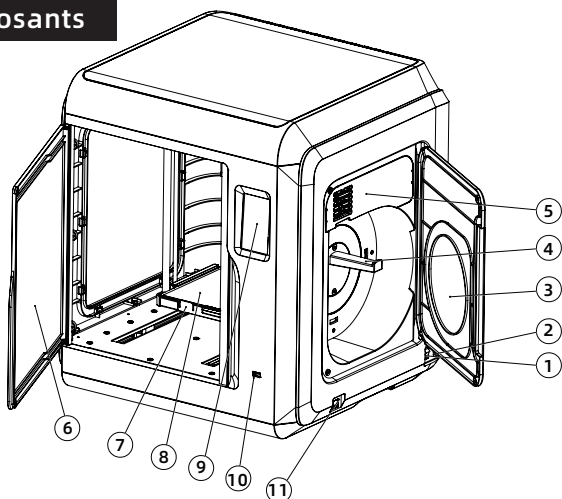

12. Extrudeuse
13. Joint du tige de guidage de filament
14. Fente de câble
15. Ventilateur pour le refroidissement du modèle
16. Ventilateur pour le refroidissement de l'extrudeuse
17. Boucle
18. Conduite d'air
19. Buse
20. Caméra(AD4)
21. Filtre à air(AD4)

Adventurer 4 lite est une plateforme en verre, sans caméra et sans filtration d'air.

Spécification de l'emballage

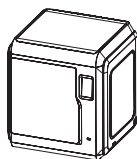

Imprimante 3D



Filament



Câble
d'alimentation



Carte de service
d'après-vente



Guide rapide

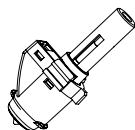

Buse 0.4-265
(pour AD4)



Tournevis

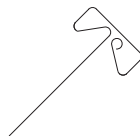

Aiguille de
nettoyage



Clé Allen

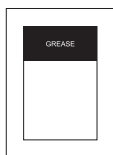

Graisse

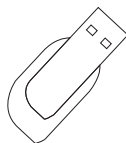

Clé usb(pour AD)

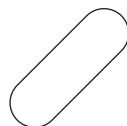

Carte de
nivellement

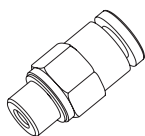

Joint du tige de
guidage de
filament

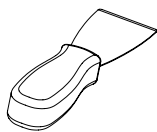

Grattoir
(pour AD4 Lite)



Colle
(pour AD4 Lite)

Installation du logiciel

Vous pouvez trouver votre package d'installation de FlashPrint dans la clé USB. Sélectionnez la version qui correspond à votre système. Vous pouvez également le télécharger depuis ce lien: <https://www.flashforge.com/download-center>.

Préparation de la machine

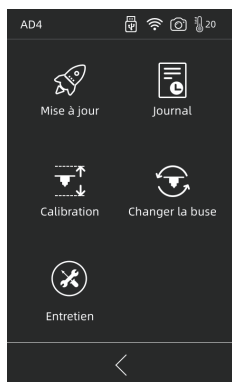

La machine a été nivelée et calibrée avant la livraison. Mais en raison du transport ou d'autres aspects, la distance entre la buse et le plateau pourrait changer. Nous vous recommandons donc d'effectuer [Calibration] après le déballage.

Cette étape est optionnelle. Voir la présentation de la fonction d'interface avant l'utilisation.

Impression

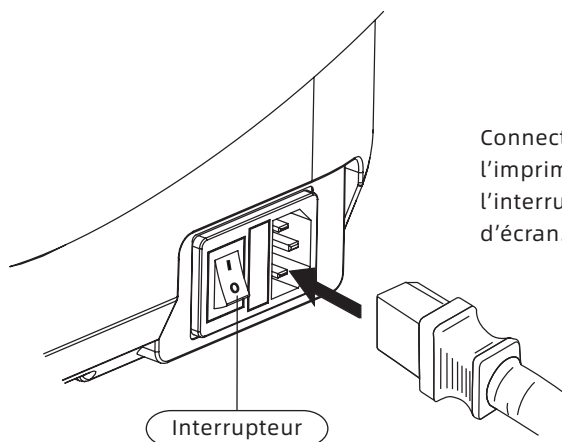

Connectez le câble à l'imprimante ; allumer l'interrupteur et la lumière d'écran.

1. Connecter à l'alimentation.

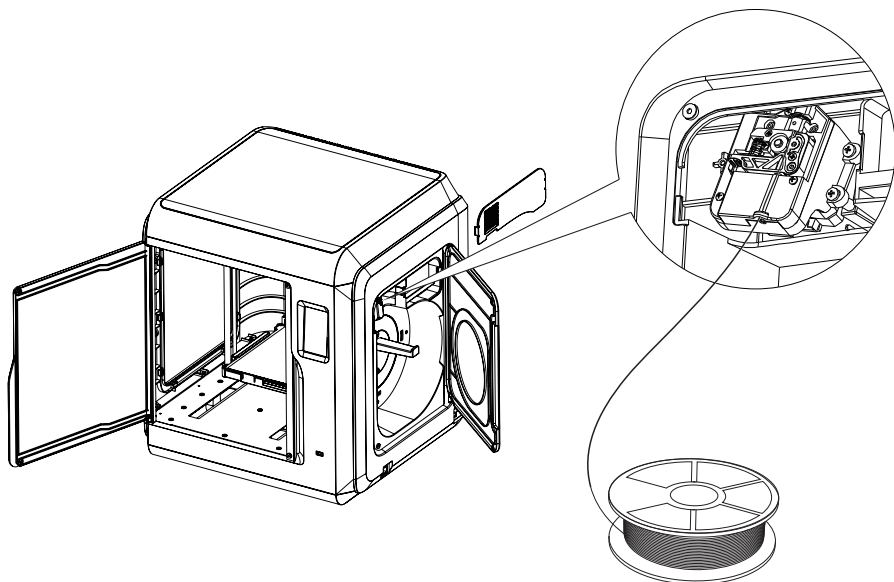

2. Charger le filament: ouvrez le couvercle de filament situé au côté droit, insérez le filament à travers l'entrée, poussez le filament dans la roue d'alimentation jusqu'à ce que vous ressentiez une légère résistance. Vérifiez que le filament se situe bien dans la roue d'alimentation. Cliquez sur [Préparer]-[Filament]-[Chargement]. Suivez les instructions. Si du filament sort de l'extrudeuse, cela indique que le chargement est réussi.

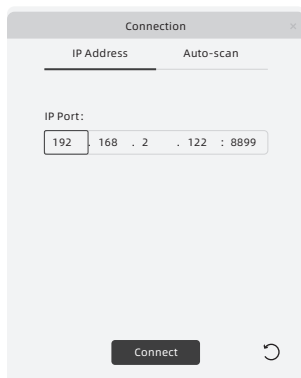
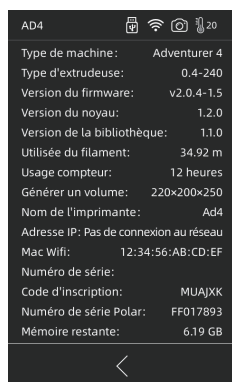

Remarque

Si vous souhaitez utiliser le navigateur pour afficher des images, l'imprimante et le PC doivent être dans un intranet (c'est-à-dire que l'imprimante et le PC se connectent au même routeur).

3. Transfert de fichier de modèle

Méthode 1: Connection au Wi-Fi

Cliquez sur [Paramètres]-[Réseau]-[WIFI], et suivez les instructions. Ouvrez le FlashPrint, cliquez sur [Imprimer], puis cliquez sur [Type Machine], sélectionnez [Flashforge Adventurer 4 / 4 Lite]. Vous pouvez entrer l'adresse IP et scanner automatiquement. Vous pouvez voir l'adresse IP dans [Paramètres] - [A propos].

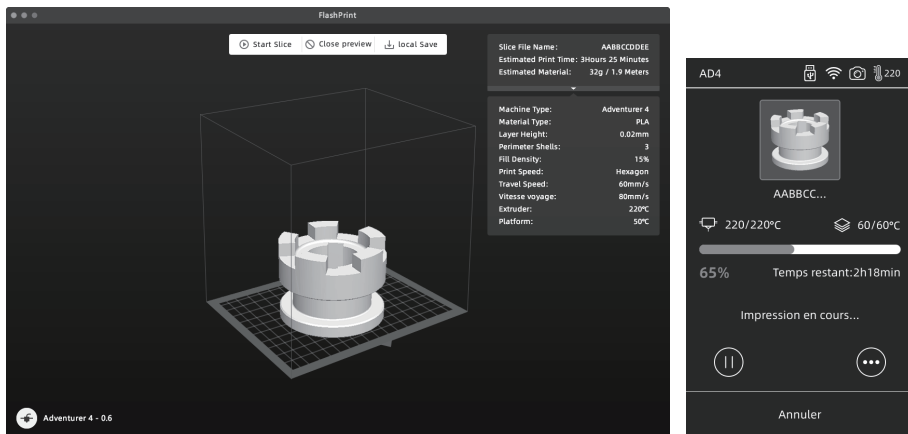

Importer un fichier stl ou obj dans l'outil de tranchage ; après le tranchage, l'imprimante se chauffe et lance automatiquement l'impression.

Méthode 2: Clé USB

Les fichiers dans la clé USB sont lisibles. Insérez la clé USB et sélectionnez le fichier à imprimer.

4. Retrait du modèle après l'impression

Adventurer 4: Retirez le plateau pliable et pliez-le pour obtenir le modèle

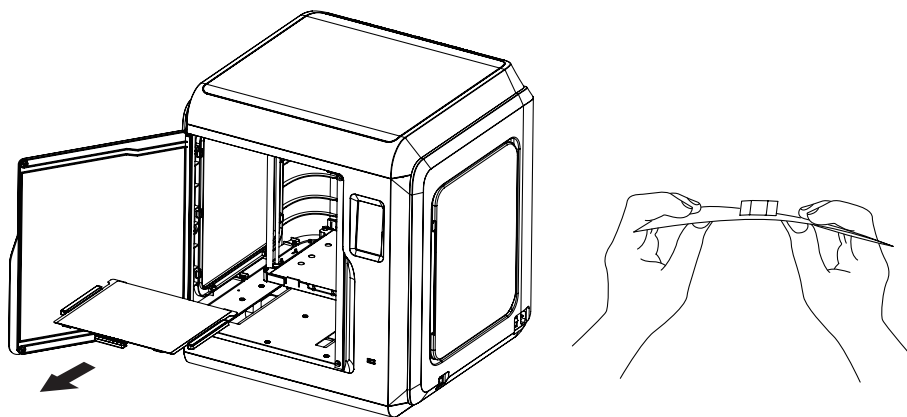

Adventurer 4 Lite: Utiliser l'outil pour supprimer le modèle

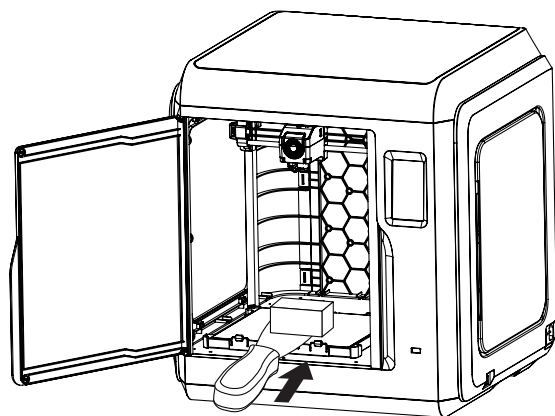

⚠ Remarque

La buse et le plateau sont toujours chauds après l'impression. Veuillez attendre qu'ils refroidissent avant de les toucher.

Nous vous recommandons de sortir le plateau de la machine avant de retirer le modèle, sinon des résidus du modèle resteraient dans la machine. Gardez l'intérieur de l'imprimante propre.

Aadventurer 4 빠른 가이드

컴포넌트 소개

1. 전원 스위치
2. 전원 소켓
3. 필라멘트 커버
4. 스폴 홀더
5. 필라멘트 흡기 커버
6. 전면 커버
7. 플랫폼 베이스
8. 빌드 플레이트
9. 터치 스크린
10. USB
11. 이더넷 입력

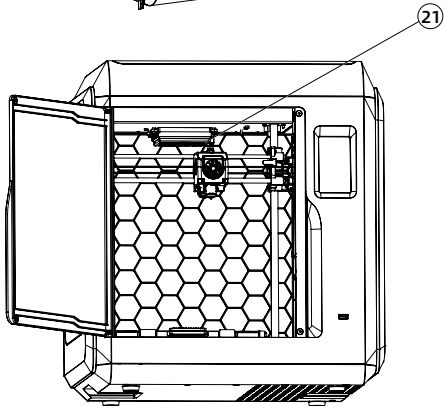
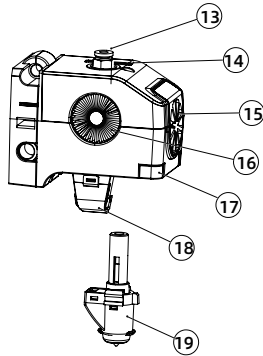
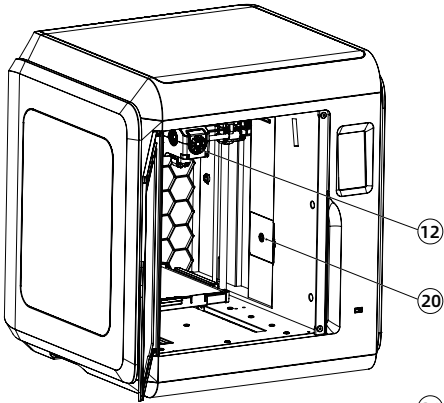
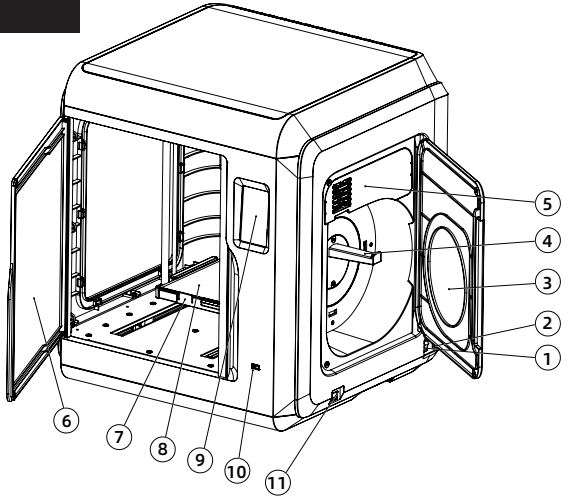

12. 익스트루더
13. 필라멘트 가이드 튜브 조인트
14. 케이블 슬롯
15. 모델 냉각용 팬
16. 익스트루더 냉각용 팬
17. 버클
18. 에어 덕트
19. 노즐
20. 카메라 (AD4)
21. 에어 필터 (AD4)

Adventurer4 lite 제품의 특징은 유리베드가 탑재, 카메라 미설치, 에어필터 미설치

패키징 세부 항목

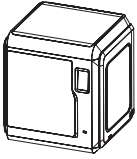

3D 프린터



필라멘트



전원 케이블



애프터 서비스
카드



빠른 가이드

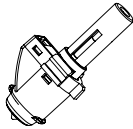

0.4-265 노즐
(AD4 제공)



스크류 드라이버

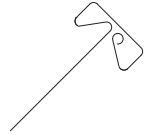

막힘 제거
핀



앨런 렌치

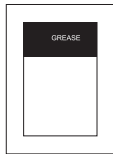

그리스

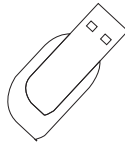

USB 디스크(AD4 제공)

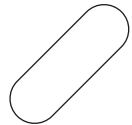

레벨링 카드

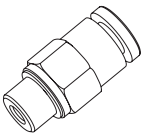

필라멘트 가이드
튜브 조인트

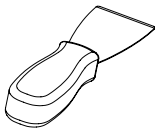

스크래퍼
(AD4 Lite 제공)



딱풀
(AD4 Lite 제공)

장 소프트웨어 설치

USB 디스크에서 FlashPrint 설치 패키지를 찾아 설치할 시스템에 해당하는 버전을 선택합니다.

또는 <https://www.flashforge.com/download-center>에서 다운로드할 수 있습니다.

장 장치 준비

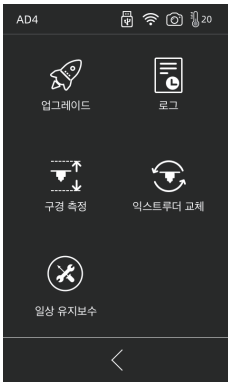

3D프린터는 배송 전에 수평을 맞추고 보정되었지만 운송 또는 기타 영향으로 인해 노즐과 플랫폼 사이의 거리가 변경될 수 있습니다. 새 포장을 풀고 [구경 측정]을 할 것을 권장합니다.

이 단계는 선택사항입니다. 인터페이스 기능소개 내용을 운영 전 참고하세요.

장 프린팅

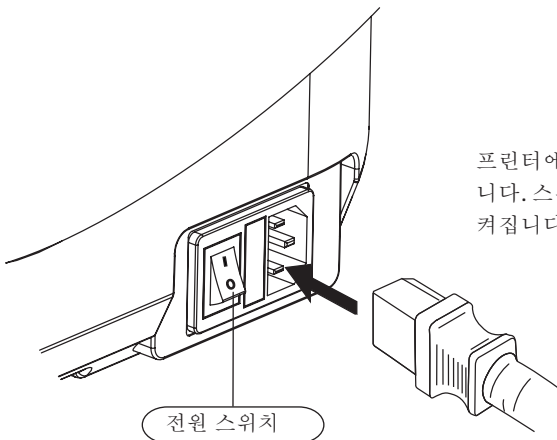

1. 전원에 연결합니다.

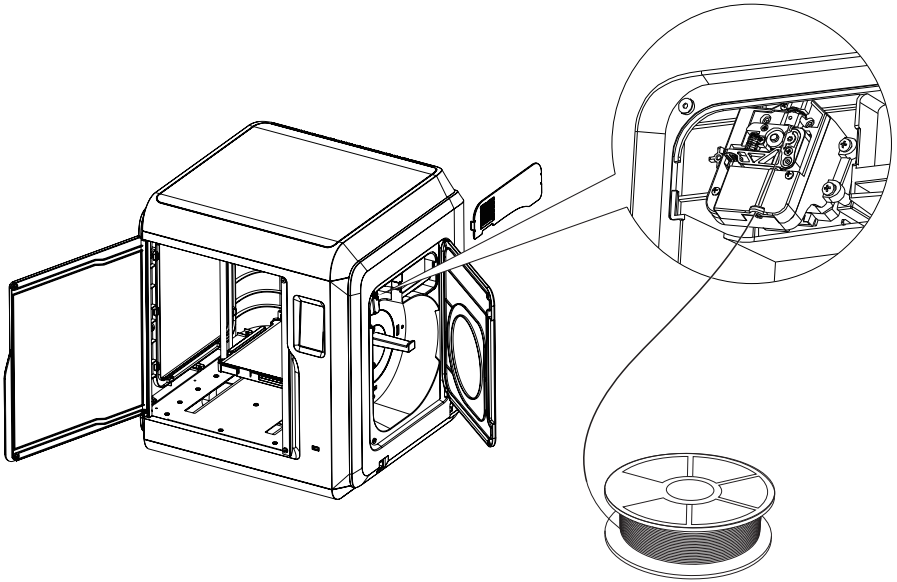

2. 필라멘트 로딩 : 오른쪽에 있는 필라멘트 덮개를 열고 필라멘트를 필라멘트 흡입구에 삽입하고 약간의 저항이 느껴질 때까지 필라멘트를 공급 휠로 밀어 넣습니다. 필라멘트가 공급 휠에 있는지 확인하십시오.

[준비]-[필라멘트]-[로딩]순서로 탭하세요. 지침을 따르십시오. 노즐에서 필라멘트가 나오면 성공을 나타냅니다.

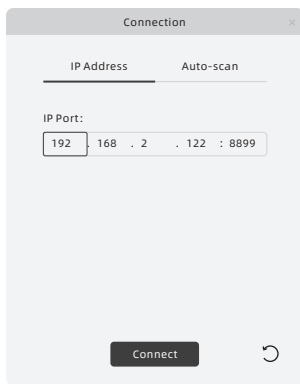

⚠ 주의

사용자가 브라우저를 사용하여 이미지를 보려면 프린터와 PC가 인터넷에 있어야 합니다 (즉, 프린터와 PC가 동일한 라우터에 연결된 상태).

3. 모델 파일 전송

방법 1: 와이파이 연결

[셋팅]-[네트워크]-[와이파이]를 누르고 지시에 따라 작동하십시오. FlashPrint를 열고 [프린팅]를 클릭한 다음 [기기 종류]을 클릭하고 [FlashForge Adventurer 4 / 4 Lite]를 선택합니다. IP 주소를 입력하거나 자동으로 스캔할 수 있습니다. IP 주소는 [셋팅]-[대하여]에서 확인할 수 있습니다.

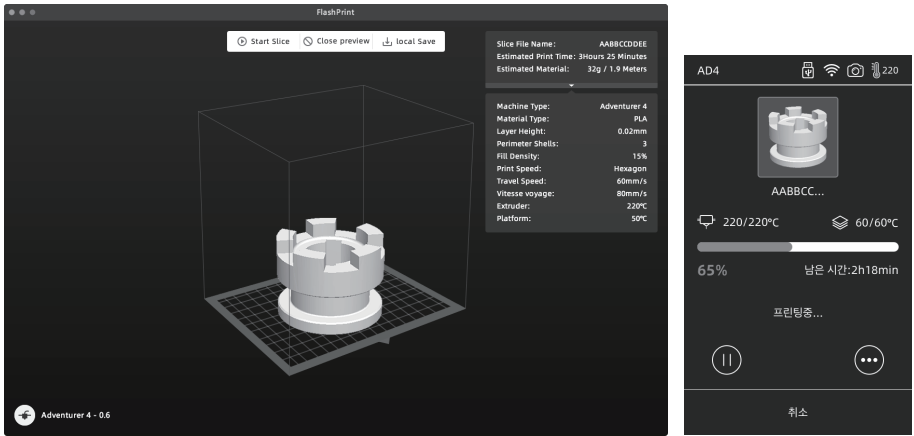

stl 또는 obj 파일을 슬라이서로 가져옵니다. 슬라이싱 후 프린터가 가열되고 자동으로 인쇄가 시작됩니다.

방법 2: USB 장치

파일은 USB 디스크에서 읽을 수 있습니다. USB 디스크를 삽입하고 프린팅할 파일을 선택합니다.

4. 출력모델 제거

Adventurer 4: (Removable) 빌드 플레이트를 꺼내고 플레이트를 구부려 모델을 얻습니다

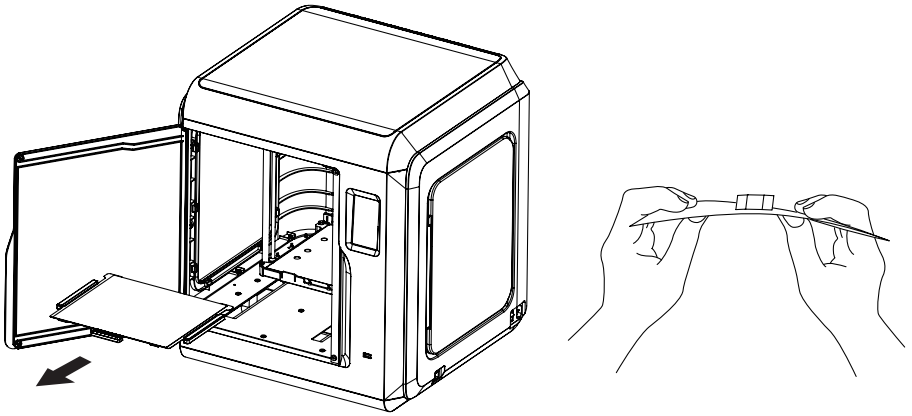

Adventurer 4 Lite: 삽질 칼을 사용하여 모델을 제거한다

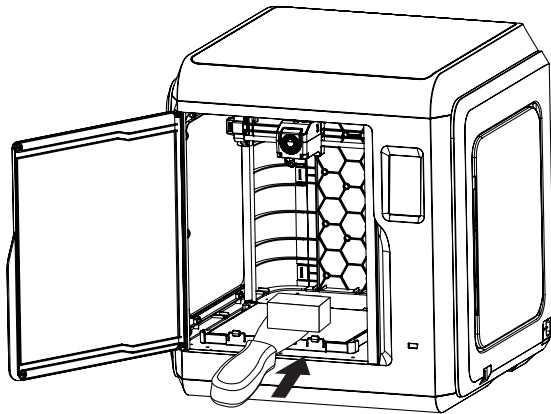

⚠ 주의

노즐과 빌드 플레이트는 인쇄를 마친 후에도 여전히 뜨겁습니다. 식을 때까지 기다렸다가 작동하십시오.

모델 제거를 위해 플레이트를 장비 외부로 가져갈 것을 권장합니다. 그렇지 않으면 모델의 잔여파편이 장비에 남게 됩니다. 프린터 내부를 항상 깨끗하게 유지하십시오.



Follow us

Zhejiang Flashforge 3D Technology Co., Ltd.

Address: No.518 XianYuan Road, Jinhua City,Zhejiang Province, China

Service Hotline: +86 579 82273989

support@flashforge.com