

Dimensions

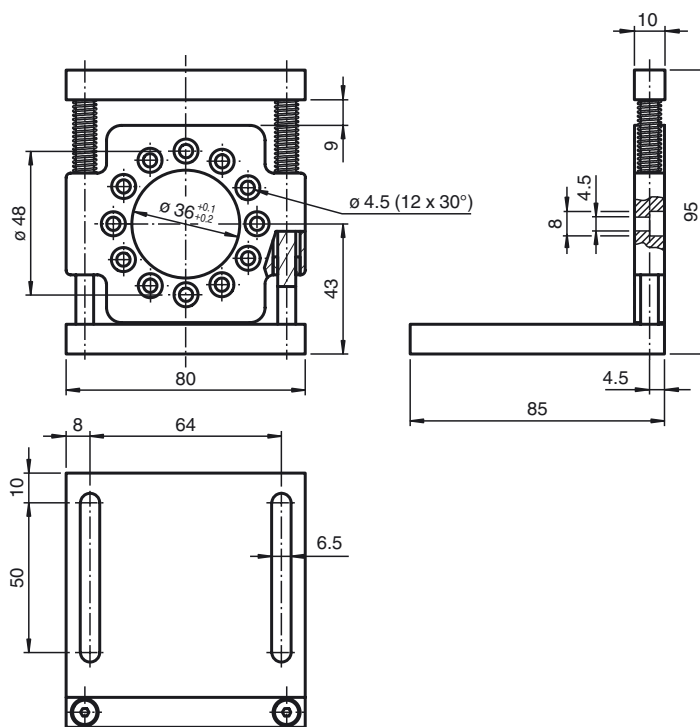

Model Number

MBT-36ALS

Spring-loaded mounting bracket with a diameter of 36 mm

Function

The extremely high-quality, spring-loaded mounting bracket is perfectly suited for mounting rotary encoders in combination with a measuring wheel with a circumference of 500 mm.

The 12 mounting holes on a pitch circle of 48 mm and offset by 30° in each case enable the optimal alignment of the rotary encoder.

The carefully tuned suspension guarantees permanent contact pressure between the measuring wheel and the object. Measuring wheels in various diameters and with different coatings are available as accessories for our rotary encoders.

Technical data

Ambient conditions

Ambient temperature -40 ... 120 °C (-40 ... 248 °F)

Mechanical specifications

Material anodized aluminum
 Mass 320 g

Release date: 2019-04-08 08:30 Date of issue: 2019-04-08 319071_eng.xml