

APPROVAL SHEET

MULTILAYER CERAMIC CAPACITORS

1825, 2220 & 2225 Sizes

NP0, X7R Dielectrics

Halogen Free & RoHS Compliance



*Contents in this sheet are subject to change without prior notice.

Multilayer Ceramic Capacitors

1. HOW TO ORDER

<u>2220</u>	<u>B</u>	<u>104</u>	<u>K</u>	<u>500</u>	<u>C</u>	<u>I</u>
Size	Dielectric	Capacitance	Tolerance	Rated voltage	Termination	Packaging style
Inch (mm) 1825 (4563) 2220 (5750) 2225 (5763)	N=NP0 B=X7R	Two significant digits followed by no. of zeros. And R is in place of decimal point. eg.: 0R5=0.5pF 1R0=1.0pF 104=10x10 ⁴ =100nF	F=±1% G=±2% J=±5% K=±10% M=±20%	Two significant digits followed by no. of zeros. And R is in place of decimal point. 250= 25 VDC 500= 50 VDC 101= 100 VDC 251= 250 VDC 501= 500 VDC 631= 630 VDC 102= 1000 VDC 152= 1500 VDC 202= 2000 VDC 252= 2500 VDC 302= 3000 VDC 402= 4000 VDC	C=Cu/Ni/Sn	T=7" reeled

2. EXTERNAL DIMENSIONS

Size Inch (mm)	L (mm)	W (mm)	T(mm) (Symbol)	M _B min (mm)
1825 (4563)	4.50±0.40	6.30±0.40	2.00±0.20 (K)	0.75±0.35
2220 (5750)	5.70±0.40	5.00±0.40	2.50±0.30 (M)	0.85±0.35
2225 (5763)	5.70±0.40	6.30±0.40	2.80±0.30 (U)	0.85±0.35

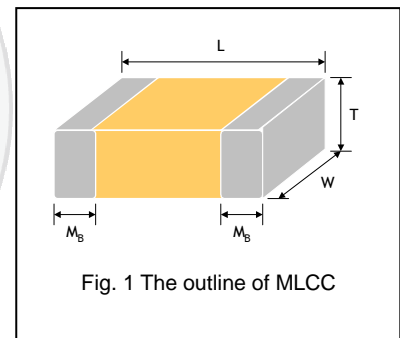

Fig. 1 The outline of MLCC

Reflow soldering only is recommended.

3. GENERAL ELECTRICAL DATA

Dielectric	NP0	X7R
Size	1825, 2220, 2225	
Capacitance*	10pF to 0.1μF	1000pF to 22μF
Capacitance tolerance	F (±1%), G (±2%), J (±5%), K (±10%)	J (±5%), K (±10%), M (±20%)
Rated voltage (WVDC)	25V, 50V, 100V, 200V, 250V, 500V, 630V, 1000V, 1500V, 2000V, 2500V, 3000V, 4000V	
Tan δ*	Cap<30pF: Q≥400+20C Cap≥30pF: Q≥1000	Cap<4.7μF: ≤2.5% Cap≥4.7μF: ≤3.5%
Operating temperature	-55 to +125°C	
Capacitance characteristic	±30ppm	±15%
Termination	Ni/Sn (lead-free termination)	

*Measured at 1.0±0.2Vrms, 1.0MHz±10% for Cap≤1000pF and 1.0±0.2Vrms, 1.0kHz±10% for Cap>1000pF, 25°C at ambient temperature for NP0.

*Measured at 1.0±0.2Vrms, 1.0kHz±10% for C≤10μF; 0.5±0.2Vrms, 120Hz±20% for C>10μF, 30~70% related humidity, 25°C ambient temperature for X7R.

** Preconditioning for Class II MLCC: Perform a heat treatment at 150±10°C for 1 hour, then leave in a mbient condition for 24±2 hours before measurement.

Multilayer Ceramic Capacitors

4-2 X7R Dielectric

DIELECTRIC	X7R																							
	1825											2220												
SIZE	50	100	200	250	500	630	1000	1500	2000	3000	4000	25	50	100	200	250	500	630	1000	1500	2000	2500	3000	4000
RATED VOLTAGE (VDC)																								
1,000pF (102)	K	K	K	K	K	K	K	K	K	K	K	K	K	K	K	K	K	K	K	K	K	K	K	K
1,200pF (122)	K	K	K	K	K	K	K	K	K	K	M	K	K	K	K	K	K	K	K	K	K	K	K	M
1,500pF (152)	K	K	K	K	K	K	K	K	K	K	M	K	K	K	K	K	K	K	K	K	K	K	K	M
1,800pF (182)	K	K	K	K	K	K	K	K	K	K	M	K	K	K	K	K	K	K	K	K	K	K	K	M
2,200pF (222)	K	K	K	K	K	K	K	K	K	K		K	K	K	K	K	K	K	K	K	K	K	K	
2,700pF (272)	K	K	K	K	K	K	K	K	K	K		K	K	K	K	K	K	K	K	K	K	K	K	
3,300pF (332)	K	K	K	K	K	K	K	K	K	K		K	K	K	K	K	K	K	K	K	K	K	K	
3,900pF (392)	K	K	K	K	K	K	K	K	K	K		K	K	K	K	K	K	K	K	K	K	K	K	
4,700pF (472)	K	K	K	K	K	K	K	K	K	K		K	K	K	K	K	K	K	K	K	K	K	K	
5,600pF (562)	K	K	K	K	K	K	K	K	K	M		K	K	K	K	K	K	K	K	K	K	K	K	
6,800pF (682)	K	K	K	K	K	K	K	K	K	M		K	K	K	K	K	K	K	K	K	M	M		
8,200pF (822)	K	K	K	K	K	K	K	K	K	M		K	K	K	K	K	K	M	M	M	M			
0.010μF (103)	K	K	K	K	K	K	K	K	K	M		K	K	K	K	K	K	M	M	M	M			
0.012μF (123)	K	K	K	K	K	K	K	M	M	U		K	K	K	K	K	K	M	M	U	U			
0.015μF (153)	K	K	K	K	K	K	K	M	M	U		K	K	K	K	K	K	M	M	U	U			
0.018μF (183)	K	K	K	K	K	K	K	M	M	U		K	K	K	K	K	K	U	U	U	U			
0.022μF (223)	K	K	K	K	K	K	K	M	M			K	K	K	K	K	K	K	U	U				
0.027μF (273)	K	K	K	K	K	K	K	U	U			K	K	K	K	K	K	K	U	U				
0.033μF (333)	K	K	K	K	K	K	K	U	U			K	K	K	K	K	K	K	U	U				
0.039μF (393)	K	K	K	K	K	K	K	U	U			K	K	K	K	K	K	K	U	U				
0.047μF (473)	K	K	K	K	K	K	K	U	U			K	K	K	K	K	K	K	U	U				
0.056μF (563)	K	K	K	K	K	K	K					K	K	K	K	K	K	K	U	U				
0.068μF (683)	K	K	K	K	K	K	K					K	K	K	K	K	K	M						
0.082μF (823)	K	K	K	K	K	K	M					K	K	K	K	K	K	M						
0.10μF (104)	K	K	K	K	K	K	M					K	K	K	K	K	K	M						
0.12μF (124)	K	K	K	K	K	K						K	K	K	K	K	K	M						
0.15μF (154)	K	K	K	K	K	K						K	K	K	K	K	K	U						
0.18μF (184)	K	K	K	K	K	K						K	K	K	K	K	K	U						
0.22μF (224)	K	K	K	K	K	K						K	K	K	K	K	K	U						
0.27μF (274)	K	K	K	K	K	K						K	K	K	K	K	K							
0.33μF (334)	K	K	K	K	K	K						K	K	K	K	K	K							
0.39μF (394)	K	K	K	K	K	K						K	K	K	K	K	K							
0.47μF (474)	K	K	K	K	K	K						K	K	K	K	K	K							
0.56μF (564)	K	K	K	K	M	M						K	K	K	K	M	M							
0.68μF (684)	K	K	K	K								K	K	K	K	M	M							
0.82μF (824)	K	K	K	K								K	K	K	K	U	U							
1.0μF (105)	K	K	K	K								K	K	K	K	U	U							
1.5μF (155)	K	K										K	K	K	M									
2.2μF (225)	K	K										K	K	K	M									
3.3μF (335)	K	K										K	K	K										
4.7μF (475)	K	K										K	K	M										
6.8μF (685)												M	M	U										
10μF (106)												U	U	U										
22μF (226)												U												

1. The letter in cell is expressed the symbol of product thickness.
2. For more information about products with special capacitance or other data, please contact WTC local representative.

Multilayer Ceramic Capacitors

DIELECTRIC		X7R											
SIZE		2225											
RATED VOLTAGE (VDC)		25	50	100	200	250	500	630	1000	1500	2000	3000	4000
Capacitance	1,000pF (102)	K	K	K	K	K	K	K	K	K	K	K	K
	1,200pF (122)	K	K	K	K	K	K	K	K	K	K	K	M
	1,500pF (152)	K	K	K	K	K	K	K	K	K	K	K	M
	1,800pF (182)	K	K	K	K	K	K	K	K	K	K	K	M
	2,200pF (222)	K	K	K	K	K	K	K	K	K	K	K	
	2,700pF (272)	K	K	K	K	K	K	K	K	K	K	K	
	3,300pF (332)	K	K	K	K	K	K	K	K	K	K	K	
	3,900pF (392)	K	K	K	K	K	K	K	K	K	K	K	
	4,700pF (472)	K	K	K	K	K	K	K	K	K	K	K	
	5,600pF (562)	K	K	K	K	K	K	K	K	K	K	M	
	6,800pF (682)	K	K	K	K	K	K	K	K	K	K	M	
	8,200pF (822)	K	K	K	K	K	K	K	K	K	K	M	
	0.010μF (103)	K	K	K	K	K	K	K	K	K	K	M	
	0.012μF (123)	K	K	K	K	K	K	K	K	M	M	M	
	0.015μF (153)	K	K	K	K	K	K	K	K	M	M	M	
	0.018μF (183)	K	K	K	K	K	K	K	K	M	M	U	
	0.022μF (223)	K	K	K	K	K	K	K	K	M	M		
	0.027μF (273)	K	K	K	K	K	K	K	K	M	M		
	0.033μF (333)	K	K	K	K	K	K	K	K	M	M		
	0.039μF (393)	K	K	K	K	K	K	K	K	U	U		
	0.047μF (473)	K	K	K	K	K	K	K	K	U	U		
	0.056μF (563)	K	K	K	K	K	K	K	K	U	U		
	0.068μF (683)	K	K	K	K	K	K	K	K				
	0.082μF (823)	K	K	K	K	K	K	K	K				
	0.10μF (104)	K	K	K	K	K	K	K	M				
	0.12μF (124)	K	K	K	K	K	K	K	U				
	0.15μF (154)	K	K	K	K	K	K	K	U				
	0.18μF (184)	K	K	K	K	K	K	K	U				
	0.22μF (224)	K	K	K	K	K	K	K	U				
	0.27μF (274)	K	K	K	K	K	K	K					
	0.33μF (334)	K	K	K	K	K	K	K					
	0.39μF (394)	K	K	K	K	K	K	K					
	0.47μF (474)	K	K	K	K	K	K	K					
0.56μF (564)	K	K	K	K	K	K	K						
0.68μF (684)	K	K	K	K	K								
0.82μF (824)	K	K	K	K	K								
1.0μF (105)	K	K	K	K	K								
1.5μF (155)	K	K	K	M	M								
2.2μF (225)	K	K	K	M	M								
3.3μF (335)	K	K	K										
4.7μF (475)	K	K											
6.8μF (685)	M	M											
10μF (106)	U	U											

1. The letter in cell is expressed the symbol of product thickness.
2. For more information about products with special capacitance or other data, please contact WTC local representative.

5. PACKAGING STYLE AND QUANTITY

Size	Thickness/Symbol (mm)		Plastic tape	
			7" reel	13" reel
1825 (4563)	2.00±0.20	K	1000	-
2220 (5750)	2.50±0.30	M	500	-
2225 (5763)	2.80±0.30	U	500	-

Unit: pieces

Multilayer Ceramic Capacitors

6. RELIABILITY TEST CONDITIONS AND REQUIREMENTS

No.	Item	Test Condition	Requirements															
1.	Visual and Mechanical	---	* No remarkable defect. * Dimensions to conform to individual specification sheet.															
2.	Capacitance	*Test temp.: Room Temperature.	* Shall not exceed the limits given in the detailed spec.															
3.	Q/ D.F. (Dissipation Factor)	Class I: (NP0) C≤1000pF, 1.0±0.2Vrms · 1MHz±10% C>1000pF, 1.0±0.2Vrms · 1KHz±10% Class II: (X7R) C≤10μF, 1.0±0.2Vrms · 1KHz±10% C>10μF, 0.5±0.2Vrms · 120Hz±20% *Before initial measurement (Class II only): To apply de-aging at 150°C for 1hr then set for 24±2 hrs at room temp.	* Q/DF: NP0: Cap≥30pF, Q≥1000; Cap<30pF, Q≥400+20C. X7R: Cap<4.7μF: ≤2.5% Cap≥4.7μF: ≤3.5%															
4.	Dielectric Strength	*To apply voltage (≤100V) 250%. *Duration: 1 to 5 sec. *Charge & discharge current less than 50mA. *To apply voltage: 200V ~ 300V ≥ 2 times V DC 500V ~ 999V ≥ 1.5 times V DC 1000V ~ 3000V ≥ 1.2 times V DC 4000V ≥ 1.1 times V DC *Duration: 1 to 5 sec. *Charge & discharge current less than 50mA.	* No evidence of damage or flash over during test.															
5.	Insulation Resistance	*Test temp.: Room Temperature. UR≤100V: To apply voltage at UR for max. 120 sec. UR>100V: To apply voltage at UR (500V max.) for 60 sec.	* ≥10GΩ or R•C≥100Ω•F whichever is smaller.															
6.	Temperature Coefficient	With no electrical load. <table border="1"> <thead> <tr> <th>T.C.</th> <th>Operating Temp</th> </tr> </thead> <tbody> <tr> <td>NP0</td> <td>-55~125°C at 25°C</td> </tr> <tr> <td>X7R</td> <td>-55~125°C at 25°C</td> </tr> </tbody> </table>	T.C.	Operating Temp	NP0	-55~125°C at 25°C	X7R	-55~125°C at 25°C	* Capacitance change: NP0: Within ±30ppm/°C. X7R: Within ±15%.									
T.C.	Operating Temp																	
NP0	-55~125°C at 25°C																	
X7R	-55~125°C at 25°C																	
7.	Adhesive Strength of Termination	Pressurizing force : 10N Test time: 10±1 sec.	* No remarkable damage or removal of the terminations.															
8.	Vibration Resistance	Vibration frequency: 10~55 Hz/min. Total amplitude: 1.5mm Test time: 6 hrs. (Two hrs each in three mutually perpendicular directions.)	* No remarkable damage. * Cap change and Q/D.F.: To meet initial spec.															
9.	Solderability	* Solder temperature: 235±5°C * Dipping time: 2±0.5 sec.	75% min. coverage of all metalized area.															
10.	Bending Test	* The middle part of substrate shall be pressurized by means of the pressurizing rod at a rate of about 1 mm per second until the deflection becomes 1 mm and then the pressure shall be maintained for 5±1 sec. * Measurement to be made after keeping at room temp. for 24±2 hrs.	* No remarkable damage. * Cap change: NP0: within ±5% or 0.5pF whichever is larger. X7R: within ±12.5%. (This capacitance change means the change of capacitance under specified flexure of substrate from the capacitance measured before the test.)															
11.	Resistance to Soldering Heat	* Solder temperature: 260±5°C * Dipping time: 10±1 sec * Preheating: 120 to 150°C for 1 minute before immerse the capacitor in a eutectic solder. * Before initial measurement (Class II only): Perform 150+0/-10°C for 1 hr and then set for 24±2 hrs at room temp. * Measurement to be made after keeping at room temp. for 24±2 hrs.	* No remarkable damage. * Cap change: NP0: within ±2.5% or 0.25pF whichever is larger. X7R: within ±7.5%. * Q/D.F., I.R. and dielectric strength: To meet initial requirements. * 25% max. leaching on each edge.															
12.	Temperature Cycle	* Conduct the five cycles according to the temperatures and time. <table border="1"> <thead> <tr> <th>Step</th> <th>Temp. (°C)</th> <th>Time (min.)</th> </tr> </thead> <tbody> <tr> <td>1</td> <td>Min. operating temp. +0/-3</td> <td>30±3</td> </tr> <tr> <td>2</td> <td>Room temp.</td> <td>2~3</td> </tr> <tr> <td>3</td> <td>Max. operating temp. +3/-0</td> <td>30±3</td> </tr> <tr> <td>4</td> <td>Room temp.</td> <td>2~3</td> </tr> </tbody> </table> * Before initial measurement (Class II only): Perform 150+0/-10°C for 1 hr and then set for 24±2 hrs at room temp. * Measurement to be made after keeping at room temp. for 24±2 hrs.	Step	Temp. (°C)	Time (min.)	1	Min. operating temp. +0/-3	30±3	2	Room temp.	2~3	3	Max. operating temp. +3/-0	30±3	4	Room temp.	2~3	* No remarkable damage. * Cap change : NP0: within ±2.5% or 0.25pF whichever is larger. X7R: within ±7.5%. * Q/D.F.: NP0: To meet initial requirements. X7R: ≤1.5 × Initial requirements. * I.R.: To meet initial requirements.
Step	Temp. (°C)	Time (min.)																
1	Min. operating temp. +0/-3	30±3																
2	Room temp.	2~3																
3	Max. operating temp. +3/-0	30±3																
4	Room temp.	2~3																

* "Room condition" Temperature: 15 to 35°C, Relative humidity: 25 to 75%, Atmospheric pressure: 86 to 106kPa.

Multilayer Ceramic Capacitors

No.	Item	Test Condition	Requirements
13.	Humidity (Damp Heat) Steady State	* Test temp.: 40±2°C * Humidity: 90~95% RH * Test time: 500+24/-0hrs. * Before initial measurement (Class II only): To apply de-aging at 150°C for 1hr then set for 24±2 hrs at room temp. * Cap. / DF(Q) / I.R. Measurement to be made after de-aging at 150°C for 1hr then set for 24±2 hrs at room temp.	* No remarkable damage. * Cap change: NP0: within ±5% or 0.5pF whichever is larger. X7R: within ±12.5%. * Q/D.F.: NP0: More than 30pF Q≥350, 10pF≤C≤30pF, Q≥275+2.5C Less than 10pF Q≥200+10C. X7R: ≤2 × Initial requirements. * I.R.: ≥1GΩ or R•C≥50Ω-F whichever is smaller.
14.	Humidity (Damp Heat) Load	* Test temp. : 40±2°C * Humidity : 90~95%RH * Test time : 500+24/-0 hrs. * To apply voltage : Rated voltage (MAX. 500V) * Before initial measurement (Class II only): To apply de-aging at 150°C for 1hr then set for 24±2 hrs at room temp. * Cap. / DF(Q) / I.R. Measurement to be made after de-aging at 150°C for 1hr then set for 24±2 hrs at room temp.	* No remarkable damage. * Cap change: NP0: ±7.5% or 0.75pF whichever is larger. X7R: within ±12.5% * Q/D.F.: NP0: More than 30pF, Q≥200; C<30pF, Q≥100+10/3C X7R: ≤2 × Initial requirements. * I.R.: ≥500MΩ or R•C≥50Ω-F whichever is smaller.
15.	High Temperature Load (Endurance)	* Test temp.: 125±3°C * To apply voltage: (1) Cap. ≥1μF: 150% of rated voltage. (2) Ur≤250V: 200% of rated voltage. (3) 250V<Ur≤500V: 150% of rated voltage. (4) 500V<Ur≤3000V: 120% of rated voltage. (5) 4000V: 110% of rated voltage. * Test time: 1000+24/-0 hrs. * Before initial measurement (Class II only): To apply de-aging at 150°C for 1hr then set for 24±2 hrs at room temp. * Cap. / DF(Q) / I.R. Measurement to be made after de-aging at 150°C for 1hr then set for 24±2 hrs at room temp.	* No remarkable damage. * Cap change: NP0: within ±3% or 0.3pF whichever is larger. X7R: within ±12.5%. * Q/D.F.: NP0: More than 30pF Q≥350, 10pF≤C≤30pF, Q≥275+2.5C Less than 10pF Q≥200+10C X7R: ≤2 × Initial requirements. * I.R.: ≥1GΩ or R•C≥50Ω-F whichever is smaller.

* "Room condition" Temperature: 15 to 35°C, Relative humidity: 25 to 75%, Atmospheric pressure: 86 to 106kPa.

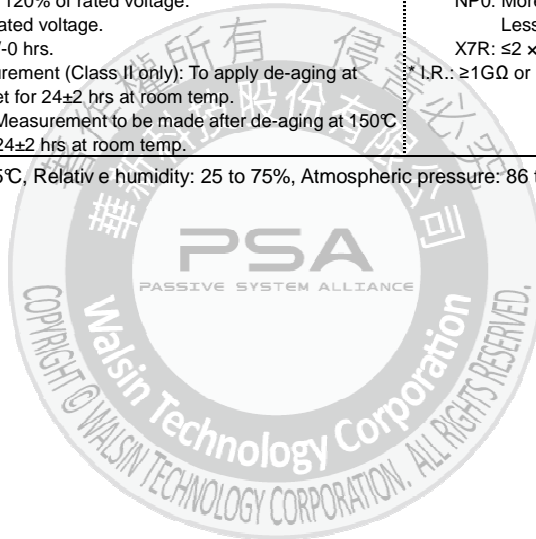

Multilayer Ceramic Capacitors

APPENDIXES

▣ **Constructions**

No.	Name	NPO	X7R
①	Ceramic material	CaZrO ₃ based	BaTiO ₃ based
②	Inner electrode		Ni
③	Termination	Inner layer	Cu
④		Middle layer	Ni
⑤		Outer layer	Sn

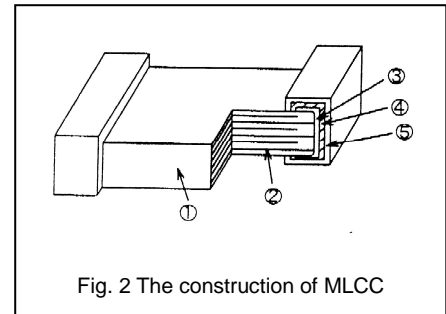

Fig. 2 The construction of MLCC

▣ **Tape & reel dimensions**

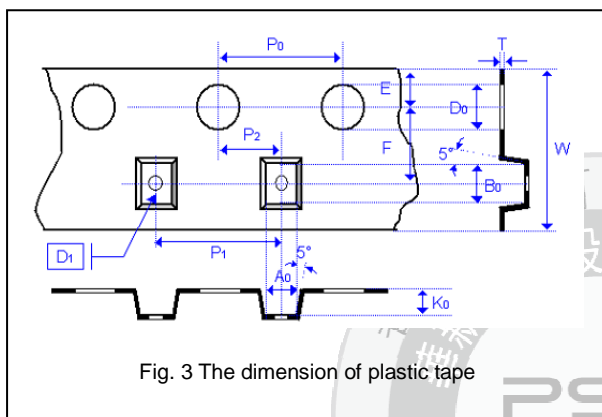

Fig. 3 The dimension of plastic tape

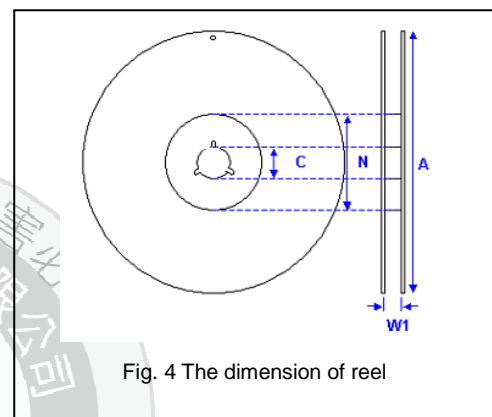

Fig. 4 The dimension of reel

Size	1825		2220		2225	
	K(2.00)	M(2.50) U(2.80)	K(2.00)	M(2.50) U(2.80)	K(2.00)	M(2.50) U(2.80)
A ₀	< 6.80	< 6.80	< 5.80	< 5.80	< 6.80	< 6.80
B ₀	< 5.30	< 5.30	< 6.50	< 6.50	< 6.50	< 6.50
T	0.30 +/-0.1	0.30 +/-0.1	0.30 +/-0.1	0.30 +/-0.1	0.30 +/-0.1	0.30 +/-0.1
K ₀	< 2.50	< 3.50	< 2.50	< 3.50	< 2.50	< 3.50
W	12.00 +/-0.30	12.00 +/-0.30	12.00 +/-0.30	12.00 +/-0.30	12.00 +/-0.30	12.00 +/-0.30
P ₀	4.00 +/-0.10	4.00 +/-0.10	4.00 +/-0.10	4.00 +/-0.10	4.00 +/-0.10	4.00 +/-0.10
10xP ₀	40.00 +/-0.20	40.00 +/-0.20	40.00 +/-0.20	40.00 +/-0.20	40.00 +/-0.20	40.00 +/-0.20
P ₁	8.00 +/-0.10	8.00 +/-0.10	8.00 +/-0.10	8.00 +/-0.10	8.00 +/-0.10	8.00 +/-0.10
P ₂	2.00 +/-0.10	2.00 +/-0.10	2.00 +/-0.10	2.00 +/-0.10	2.00 +/-0.10	2.00 +/-0.10
D ₀	1.50 +0.1/-0	1.50 +0.1/-0	1.50 +0.1/-0	1.50 +0.1/-0	1.50 +0.1/-0	1.50 +0.1/-0
D ₁	1.50 +/-0.10	1.50 +/-0.10	1.50 +/-0.10	1.50 +/-0.10	1.50 +/-0.10	1.50 +/-0.10
E	1.75 +/-0.10	1.75 +/-0.10	1.75 +/-0.10	1.75 +/-0.10	1.75 +/-0.10	1.75 +/-0.10
F	5.50 +/-0.05	5.50 +/-0.05	5.50 +/-0.05	5.50 +/-0.05	5.50 +/-0.05	5.50 +/-0.05

Size	1825, 2220, 2225
Reel size	7"
C	13.0+0.5/-0.2
W ₁	12.4+2.0/-0
A	178.0±1.0
N	60.0+1.0/-0

APPLICATION NOTES

▣ Storage

To prevent the damage of solderability of terminations, the following storage conditions are recommended:

Indoors under 5 ~ 40°C and 20% ~ 70% RH; MSL Level 1.

No harmful gases containing sulfuric acid, ammonia, hydrogen sulfide or chlorine.

Packaging should not be opened until the capacitors are required for use. If opened, the pack should be re-sealed as soon as is practicable. Taped product should be stored out of direct sunlight, which might promote deterioration in tape or adhesion performance. The capacitors should be used within 6 months and checked the solderability before use.

▣ Handling

Chip capacitors are dense, hard, brittle, and abrasive materials. They are liable to suffer mechanical damage, in the form of cracks or chips. Chip Capacitors should be handled with care to avoid contamination or damage. To use vacuum or plastic tweezers to pick up or plastic tweezers is recommended for manual placement. Tape and reeled packages are suitable for automatic pick and placement machine.

▣ Preheat

In order to minimize the risk of thermal shock during soldering, a carefully controlled preheat is required. The rate of preheat should not exceed 4°C per second and the final preheat temperature should be within 100°C of the soldering temperature for small chips such as 0402, 0603, 0805 and 1206, within 50°C of the soldering temperature for bigger chips such as 1210, 1808, 1812, 1825, 2220 and 2225, etc.

▣ Soldering

Use middy activated rosin RA and RMA fluxes do not use activated flux. The amount of solder in each solder joint should be controlled to prevent the damage of chip capacitors caused by the stress between solder, chips, and substrate.

Hand soldering with temperature-controlled iron not exceeding 30 watts and diameter of tip less than 1.2 mm is recommended, tip of iron should not contact the ceramic body directly, and the temperature of iron should be set to not more than 260°C.

For bigger chips such as 1210, 1808, 1812, 2220 and 2225, etc. wave soldering and hand soldering are no recommended.

Refer IPC/JEDEC J-STD-020D Method recommended soldering profiles:

Reflow not sooner than 15 minutes and not longer than 4 hrs after removal from the temperature/humidity chamber, subject the sample to 3 cycle of the appropriate reflow conditions as defined as blow Table description.

Profile Feature	Pb-Free Assembly
Preheat/Soak	
Temperature Min.(T _{S min})	150°C
Temperature Max.(T _{S max})	200°C
Time(t _S) from (T _{S min} to T _{S max})	60 to 120 seconds
Ramp-up rate(T _L to T _P)	3°C/second max.
Liquidous temperature(T _L)	217°C
Time(t _L) maintained above T _L	60 to 150 seconds
Peak package body temperature(T _P)	For user T _P must not exceed the Classification temp 260°C For suppliers T _P must equal or exceed the Classification temp 260°C
Time(T _P)* within 5°C of the specified classification temperature(T _C)	30* second
Ramp-down rate (T _P to T _L)	6°C/second max.
Time 25°C to peak temperature 260°C	8 minutes max.

Multilayer Ceramic Capacitors

Lead-free: Soldering temperature = 235 to 260°C, depending on product.

Maximum temperature = Minimum temperature (235°C) + ΔT + Tolerance for oven process and measurement (5 ~ 7°C)

Time at peak temperature = 10sec, Dwell above 217°C = 90sec, Ramping rate = 3°C/sec (heating) and 6°C/sec (heating).

Classification Reflow Profiles

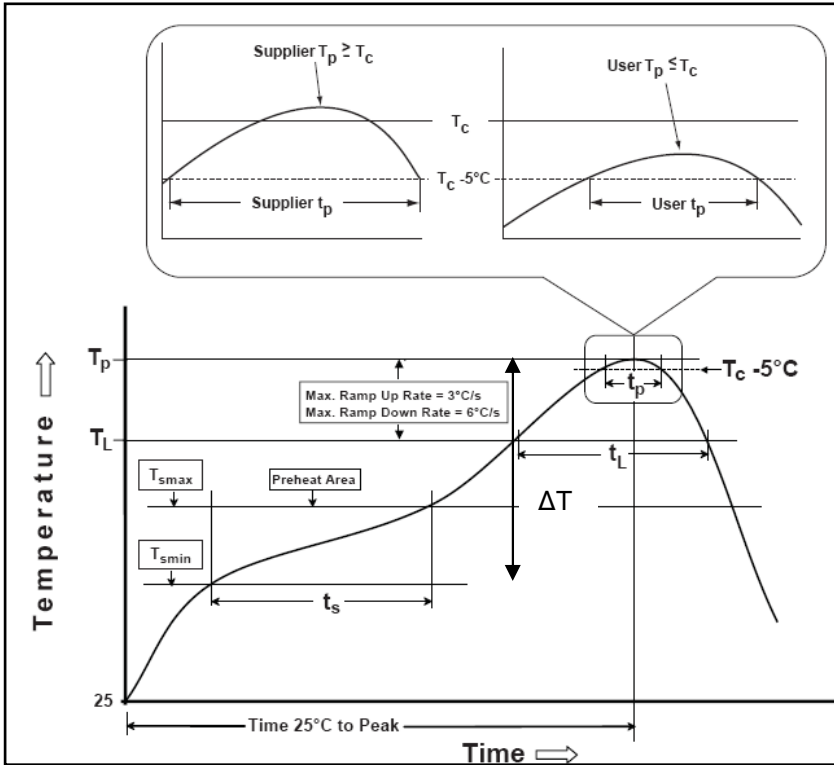

Chip Size	ΔT
0805, 1206	100 °C
1210, 1808, 1812, 1825, 2211, 2220, 2225	50°C

Soldering	Solder Temp. (Tc)	Soldering Time (tp)
Reflow	235 – 260 °C	< 15 sec.

Note: For example, Tc is 260°C and time tp is 15 seconds.

For user: The peak temperature must not exceed 260°C. The time above 255°C must not exceed 15 seconds.

☐ **Cooling**

After soldering, cool the chips and the substrate gradually to room temperature. Natural cooling in air is recommended to minimize stress in the solder joint. A cooling rate not exceeding 4°C per second should be used when forced cooling is necessary.

☐ **Cleaning**

All flux residues must be removed by using suitable electronic-grade vapor-cleaning solvents to eliminate contamination that could cause electrolytic surface corrosion. Good results can be obtained by using ultrasonic cleaning of the solvent. The choice of the proper system is depends upon many factors such as component mix, flux, and solder paste and assembly method. The ability of the cleaning system to remove flux residues and contamination from under the chips is very important.