

Seede Studio BeagleBone® Green Wireless is a joint effort by [BeagleBoard.org](https://beagleboard.org) and Seede Studio. It is based on the open-source hardware design of [BeagleBone® Black](#) and developed into this differentiated version. Seede Studio BeagleBone® Green Wireless has included a high-performance flexible WiFi/Bluetooth interface and two Grove connectors, making it easier to connect to the large family of Grove sensors. The on-board HDMI and Ethernet are removed to make room for these wireless features and Grove connectors.

## Features

---

- **Fully Compatible with BeagleBone® Black**
- **Processor: AM335x 1GHz ARM® Cortex-A8**
  - 512MB DDR3 RAM
  - 4GB 8-bit eMMC on-board flash storage
  - 3D graphics accelerator
  - NEON floating-point accelerator
  - 2x PRU 32-bit microcontrollers
- **Connectivity**
  - USB client for power & communications
  - USB host with 4-port hub
  - WiFi 802.11 b/g/n 2.4GHz
  - Bluetooth 4.1 with BLE
  - 2x 46 pin headers
  - 2x Grove connectors (I2C and UART)
- **Software Compatibility**

- Debian
- Android
- Ubuntu
- Cloud9 IDE on Node.js w/ BoneScript library
- plus much more

## Specification

Item	Value
Processor	AM335x 1GHz ARM Cortex-A8
RAM	512MB DDR3
on-board Flash Storage	4GB eMMC
CPU Supports	NEON floating-point & 3D graphics accelerator
Micro USB Supports	powering & communications
USB	USB2.0 Host *4
Grove Connectors	2 (One I2C and One UART)
GPIO	2 x 46 pin headers
Ethernet	Wi-Fi 802.11b/g/n 2.4GHz and Bluetooth 4.1 LE
Operating Temperature	0 ~ 75

## Application Ideas

- Internet of Things
- Smart House
- Industrial
- Automation & Process Control
- Human Machine Interface
- Sensor Hub
- Robot

### Seeed Studio BeagleBone® Green Wireless Starter Tutorial #1-#6

Here are some tutorials for the starters to use some Grove modules to realize their interesting ideas with Seeed Studio BeagleBone® Green Wireless. The tutorials are based on Python and mraa/upm library.

**#1 The Breath LED**

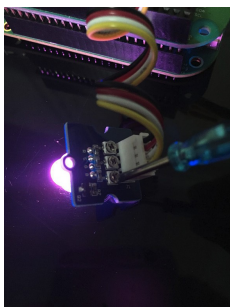

**#2 Storm on your table**

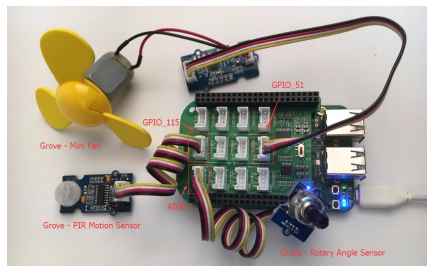

**#3 Speak Louuuuudly**

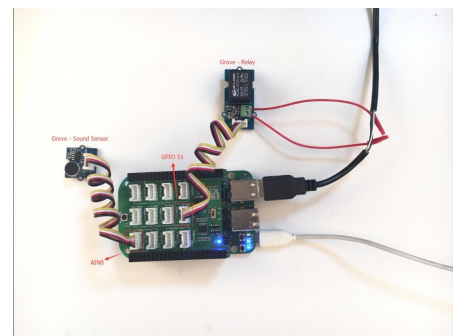

[MAKE IT NOW!](#)

[MAKE IT NOW!](#)

[MAKE IT NOW!](#)

**#4 How hot is it today?**

**#5 Where are you?**

**#6 My Little alarm clock**

#4 How hot is it today?

#5 Where are you?

#6 My Little alarm clock

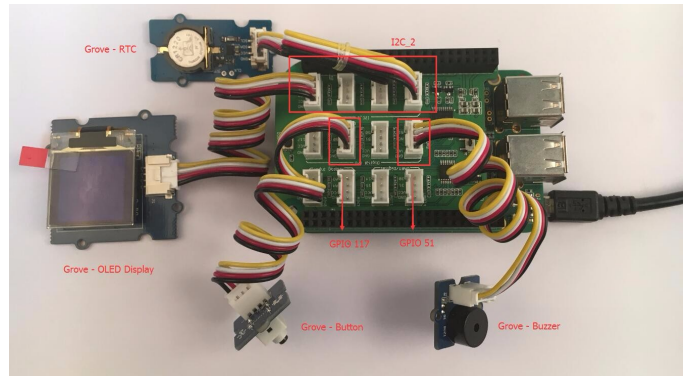
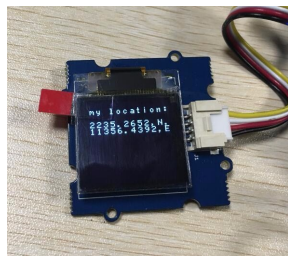

MAKE IT NOW!

MAKE IT NOW!

MAKE IT NOW!

Funny Projects

Bluetooth Device Detection

Home Control Center

SAP HCP IoT Service

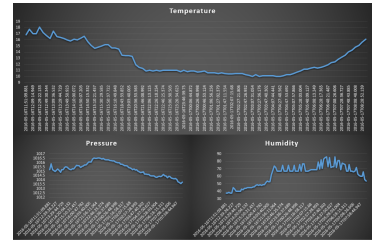
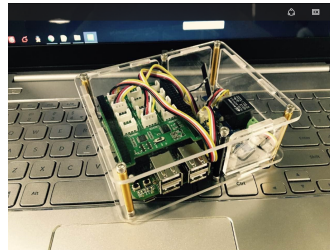
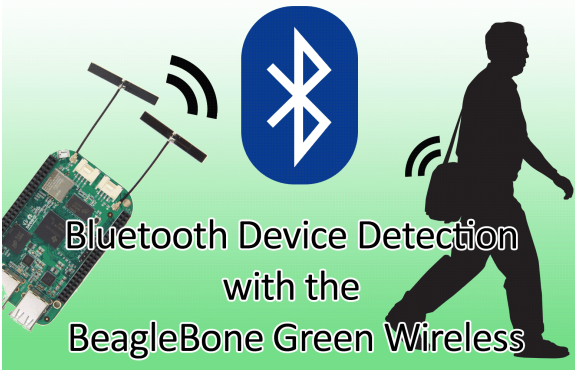

MAKE IT NOW!

MAKE IT NOW!

MAKE IT NOW!

Hardware Overview

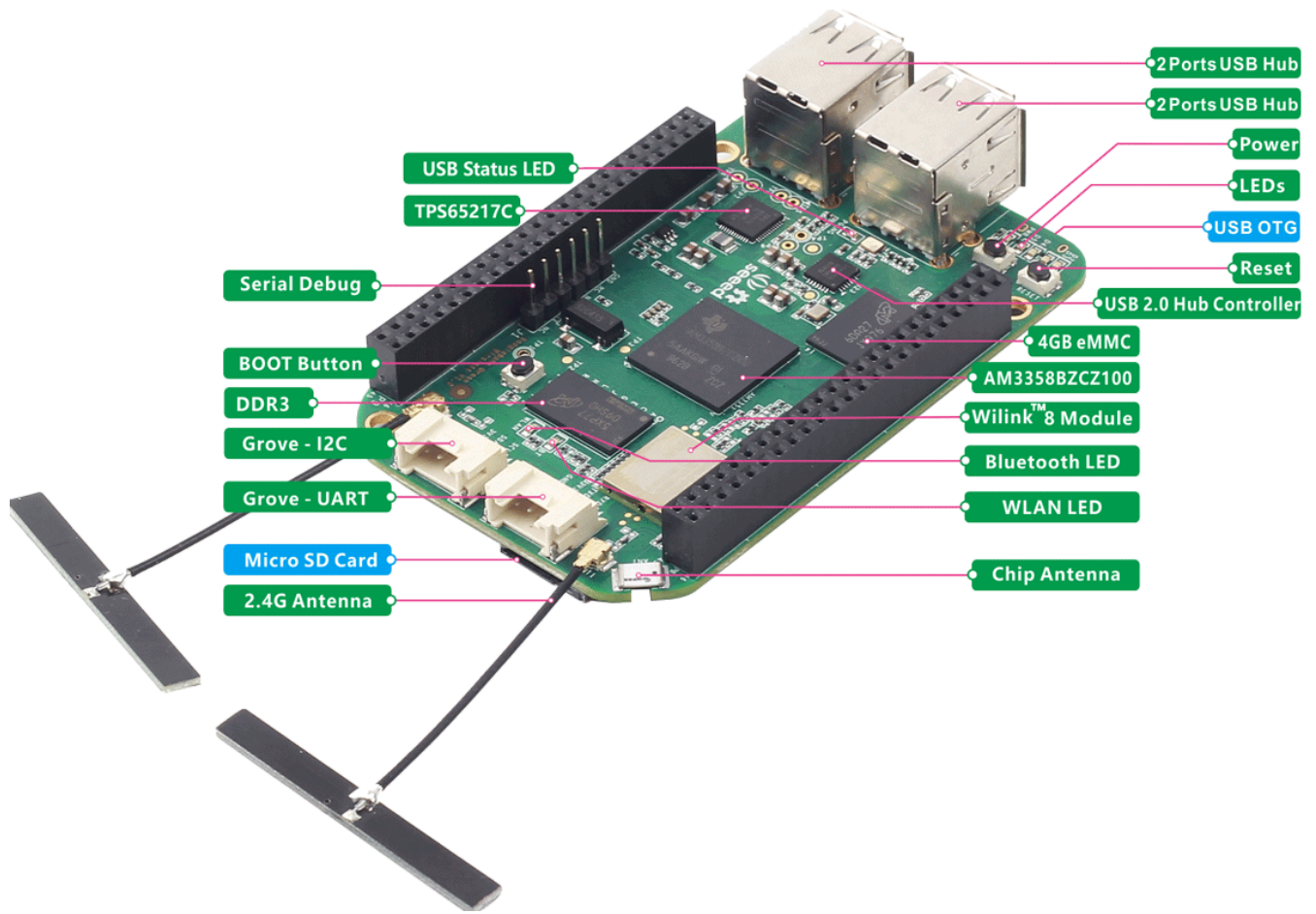

### Pin map

Each digital I/O pin has 8 different modes that can be selected, including GPIO.

### 65 Possible Digital I/Os

In GPIO mode, each digital I/O can produce interrupts.



# Cape Expansion Headers

**P9**

DGND	1	2	DGND
VDD_3V3	3	4	VDD_3V3
VDD_5V	5	6	VDD_5V
SYS_5V	7	8	SYS_5V
PWR_BTN	9	10	SYS_RESETa
UART4_RXD	11	12	GPIO_60
UART4_TXD	13	14	EHRPWM1A
GPIO_48	15	16	EHRPWM1B
SPI0_CS0	17	18	SPI0_D1
I2C2_SCL	19	20	I2C2_SDA
UART2_TXD	21	22	UART2_RXD
GPIO_49	23	24	UART1_TXD
GPIO_117	25	26	UART1_RXD
GPIO_115	27	28	GPIO_113
GPIO_111	29	30	GPIO_112
GPIO_110	31	32	VDD_ADC
AIN4	33	34	GNDA_ADC
AIN6	35	36	AIN5
AIN2	37	38	AIN3
AIN0	39	40	AIN1
GPIO_20	41	42	ECAPPWM0
DGND	43	44	DGND
DGND	45	46	DGND

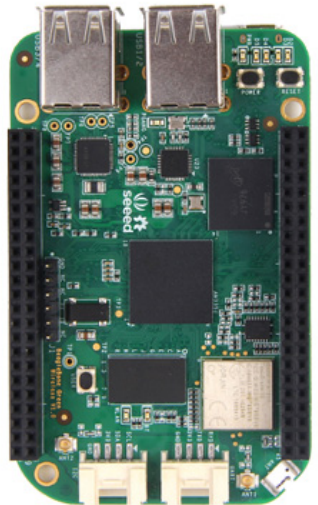

**P8**

DGND	1	2	DGND
MMC1_DAT6	3	4	MMC1_DAT7
MMC1_DAT2	5	6	MMC1_DAT3
GPIO_66	7	8	GPIO_67
GPIO_69	9	10	GPIO_68
GPIO_45	11	12	GPIO_44
EHRPWM2B	13	14	GPIO_26
GPIO_47	15	16	GPIO_46
GPIO_27	17	18	GPIO_65
EHRPWM2A	19	20	MMC1_CMD
MMC1_CLK	21	22	MMC1_DAT5
MMC1_DAT4	23	24	MMC1_DAT1
MMC1_DAT0	25	26	GPIO_61
GPIO_86	27	28	GPIO_88
GPIO_87	29	30	GPIO_89
GPIO_10	31	32	GPIO_11
GPIO_9	33	34	GPIO_81
GPIO_8	35	36	GPIO_80
GPIO_78	37	38	GPIO_79
GPIO_76	39	40	GPIO_77
GPIO_74	41	42	GPIO_75
GPIO_72	43	44	GPIO_73
GPIO_70	45	46	GPIO_71

**LEGEND**

- Power/Ground/Reset
- Available Digital
- Available PWM
- Shared I2C Bus
- Reconfigurable Digital
- Analog Inputs (1.8V)

## PWMs and Timers

Up to 8 digital I/O pins can be configured with pulse-width modulators (PWM) to produce signals to control motors or create pseudo analog voltage levels, without taking up any extra CPU cycles.

# 8 PWMs and 4 timers

P9				P8			
DGND	1	2	DGND	DGND	1	2	DGND
VDD_3V3	3	4	VDD_3V3	GPIO_38	3	4	GPIO_39
VDD_5V	5	6	VDD_5V	GPIO_34	5	6	GPIO_35
SYS_5V	7	8	SYS_5V	TIMER4	7	8	TIMER7
PWR_BUT	9	10	SYS_RESETN	TIMER5	9	10	TIMER6
GPIO_30	11	12	GPIO_60	GPIO_45	11	12	GPIO_44
GPIO_31	13	14	EHRPWM1A	EHRPWM2B	13	14	GPIO_26
GPIO_48	15	16	EHRPWM1B	GPIO_47	15	16	GPIO_46
GPIO_5	17	18	GPIO_4	GPIO_27	17	18	GPIO_65
I2C2_SCL	19	20	I2C2_SDA	EHRPWM2A	19	20	GPIO_63
EHRPWMOB	21	22	EHRPWMOA	GPIO_62	21	22	GPIO_37
GPIO_49	23	24	GPIO_15	GPIO_36	23	24	GPIO_33
GPIO_117	25	26	GPIO_14	GPIO_32	25	26	GPIO_61
GPIO_115	27	28	ECAPPWM2	GPIO_86	27	28	GPIO_88
EHRPWMOB	29	30	GPIO_112	GPIO_87	29	30	GPIO_89
EHRPWMOA	31	32	VDD_ADC	GPIO_10	31	32	GPIO_11
AIN4	33	34	GND_ADC	GPIO_9	33	34	EHRPWM1B
AIN6	35	36	AIN5	GPIO_8	35	36	EHRPWM1A
AIN2	37	38	AIN3	GPIO_78	37	38	GPIO_79
AIN0	39	40	AIN1	GPIO_76	39	40	GPIO_77
GPIO_20	41	42	ECAPPWMO	GPIO_74	41	42	GPIO_75
DGND	43	44	DGND	GPIO_72	43	44	GPIO_73
DGND	45	46	DGND	EHRPWM2A	45	46	EHRPWM2B

## Analog Inputs

Make sure you don't input more than 1.8V to the analog input pins. This is a single 12-bit analog-to-digital converter with 8 channels, 7 of which are made available on the headers.

# 7 analog inputs (1.8V)

P9				P8			
DGND	1	2	DGND	DGND	1	2	DGND
VDD_3V3	3	4	VDD_3V3	GPIO_38	3	4	GPIO_39
VDD_5V	5	6	VDD_5V	GPIO_34	5	6	GPIO_35
SYS_5V	7	8	SYS_5V	GPIO_66	7	8	GPIO_67
PWR_BUT	9	10	SYS_RESETN	GPIO_69	9	10	GPIO_68
GPIO_30	11	12	GPIO_60	GPIO_45	11	12	GPIO_44
GPIO_31	13	14	GPIO_50	GPIO_23	13	14	GPIO_26
GPIO_48	15	16	GPIO_51	GPIO_47	15	16	GPIO_46
GPIO_5	17	18	GPIO_4	GPIO_27	17	18	GPIO_65
I2C2_SCL	19	20	I2C2_SDA	GPIO_22	19	20	GPIO_63
GPIO_3	21	22	GPIO_2	GPIO_62	21	22	GPIO_37
GPIO_49	23	24	GPIO_15	GPIO_36	23	24	GPIO_33
GPIO_117	25	26	GPIO_14	GPIO_32	25	26	GPIO_61
GPIO_115	27	28	GPIO_113	GPIO_86	27	28	GPIO_88
GPIO_111	29	30	GPIO_112	GPIO_87	29	30	GPIO_89
GPIO_110	31	32	VDD_ADC	GPIO_10	31	32	GPIO_11
AIN4	33	34	GND_ADC	GPIO_9	33	34	GPIO_81
AIN6	35	36	AIN5	GPIO_8	35	36	GPIO_80
AIN2	37	38	AIN3	GPIO_78	37	38	GPIO_79
AIN0	39	40	AIN1	GPIO_76	39	40	GPIO_77
GPIO_20	41	42	GPIO_7	GPIO_74	41	42	GPIO_75
DGND	43	44	DGND	GPIO_72	43	44	GPIO_73
DGND	45	46	DGND	GPIO_70	45	46	GPIO_71

## UART

There is a dedicated header for getting to the UART0 pins and connecting a debug cable. Five additional serial ports are brought to the expansion headers, but one of them only has a single direction brought to the headers.

# 4 UARTs and 1 TX only

P9				P8			
DGND	1	2	DGND	DGND	1	2	DGND
VDD_3V3	3	4	VDD_3V3	GPIO_38	3	4	GPIO_39
VDD_5V	5	6	VDD_5V	GPIO_34	5	6	GPIO_35
SYS_5V	7	8	SYS_5V	GPIO_66	7	8	GPIO_67
PWR_BUT	9	10	SYS_RESETN	GPIO_69	9	10	GPIO_68
UART4_RXD	11	12	GPIO_60	GPIO_45	11	12	GPIO_44
UART4_TXD	13	14	GPIO_50	GPIO_23	13	14	GPIO_26
GPIO_48	15	16	GPIO_51	GPIO_47	15	16	GPIO_46
GPIO_5	17	18	GPIO_4	GPIO_27	17	18	GPIO_65
UART1_RTSN	19	20	UART1_CTSN	GPIO_22	19	20	GPIO_63
UART2_TXD	21	22	UART2_RXD	GPIO_62	21	22	GPIO_37
GPIO_49	23	24	UART1_TXD	GPIO_36	23	24	GPIO_33
GPIO_117	25	26	UART1_RXD	GPIO_32	25	26	GPIO_61
GPIO_115	27	28	GPIO_113	GPIO_86	27	28	GPIO_88
GPIO_111	29	30	GPIO_112	GPIO_87	29	30	GPIO_89
GPIO_110	31	32	VDD_ADC	UART5_CTSN+	31	32	UART5_RTSN
AIN4	33	34	GND_A_ADC	UART4_RTSN	33	34	UART3_RTSN
AIN6	35	36	AIN5	UART4_CTSN	35	36	UART3_CTSN
AIN2	37	38	AIN3	UART5_TXD+	37	38	UART5_RXD+
AIN0	39	40	AIN1	GPIO_76	39	40	GPIO_77
GPIO_20	41	42	UART3_TXD	GPIO_74	41	42	GPIO_75
DGND	43	44	DGND	GPIO_72	43	44	GPIO_73
DGND	45	46	DGND	GPIO_70	45	46	GPIO_71

## I2C

The first I2C bus is utilized for reading EEPROMS on cape add-on boards and can't be used for other digital I/O operations without interfering with that function, but you can still use it to add other I2C devices at available addresses. The second I2C bus is available for you to configure and use.



# 2 I2C ports

P9				P8			
DGND	1	2	DGND	DGND	1	2	DGND
VDD_3V3	3	4	VDD_3V3	GPIO_38	3	4	GPIO_39
VDD_5V	5	6	VDD_5V	GPIO_34	5	6	GPIO_35
SYS_5V	7	8	SYS_5V	GPIO_66	7	8	GPIO_67
PWR_BUT	9	10	SYS_RESETN	GPIO_69	9	10	GPIO_68
GPIO_30	11	12	GPIO_60	GPIO_45	11	12	GPIO_44
GPIO_31	13	14	GPIO_50	GPIO_23	13	14	GPIO_26
GPIO_48	15	16	GPIO_51	GPIO_47	15	16	GPIO_46
I2C1_SCL	17	18	I2C1_SDA	GPIO_27	17	18	GPIO_65
I2C2_SCL	19	20	I2C2_SDA	GPIO_22	19	20	GPIO_63
I2C2_SCL	21	22	I2C2_SDA	GPIO_62	21	22	GPIO_37
GPIO_49	23	24	I2C1_SCL	GPIO_36	23	24	GPIO_33
GPIO_117	25	26	I2C1_SDA	GPIO_32	25	26	GPIO_61
GPIO_115	27	28	GPIO_113	GPIO_86	27	28	GPIO_88
GPIO_111	29	30	GPIO_112	GPIO_87	29	30	GPIO_89
GPIO_110	31	32	VDD_ADC	GPIO_10	31	32	GPIO_11
AIN4	33	34	GND_ADC	GPIO_9	33	34	GPIO_81
AIN6	35	36	AIN5	GPIO_8	35	36	GPIO_80
AIN2	37	38	AIN3	GPIO_78	37	38	GPIO_79
AIN0	39	40	AIN1	GPIO_76	39	40	GPIO_77
GPIO_20	41	42	GPIO_7	GPIO_74	41	42	GPIO_75
DGND	43	44	DGND	GPIO_72	43	44	GPIO_73
DGND	45	46	DGND	GPIO_70	45	46	GPIO_71

## SPI

For shifting out data fast, you might consider using one of the SPI ports.

# 2 SPI ports

P9				P8			
DGND	1	2	DGND	DGND	1	2	DGND
VDD_3V3	3	4	VDD_3V3	GPIO_38	3	4	GPIO_39
VDD_5V	5	6	VDD_5V	GPIO_34	5	6	GPIO_35
SYS_5V	7	8	SYS_5V	GPIO_66	7	8	GPIO_67
PWR_BUT	9	10	SYS_RESETN	GPIO_69	9	10	GPIO_68
GPIO_30	11	12	GPIO_60	GPIO_45	11	12	GPIO_44
GPIO_31	13	14	GPIO_50	GPIO_23	13	14	GPIO_26
GPIO_48	15	16	GPIO_51	GPIO_47	15	16	GPIO_46
SPIO_CS0	17	18	SPIO_D1	GPIO_27	17	18	GPIO_65
SPI1_CS1	19	20	SPI1_CS0	GPIO_22	19	20	GPIO_63
SPIO_DO	21	22	SPIO_SCLK	GPIO_62	21	22	GPIO_37
GPIO_49	23	24	GPIO_15	GPIO_36	23	24	GPIO_33
GPIO_117	25	26	GPIO_14	GPIO_32	25	26	GPIO_61
GPIO_115	27	28	SPI1_CS0	GPIO_86	27	28	GPIO_88
SPI1_DO	29	30	SPI1_D1	GPIO_87	29	30	GPIO_89
SPI1_SCLK	31	32	VDD_ADC	GPIO_10	31	32	GPIO_11
AIN4	33	34	GND_ADC	GPIO_9	33	34	GPIO_81
AIN6	35	36	AIN5	GPIO_8	35	36	GPIO_80
AIN2	37	38	AIN3	GPIO_78	37	38	GPIO_79
AIN0	39	40	AIN1	GPIO_76	39	40	GPIO_77
GPIO_20	41	42	SPI1_CS1	GPIO_74	41	42	GPIO_75
DGND	43	44	DGND	GPIO_72	43	44	GPIO_73
DGND	45	46	DGND	GPIO_70	45	46	GPIO_71

Mechincal Drawing

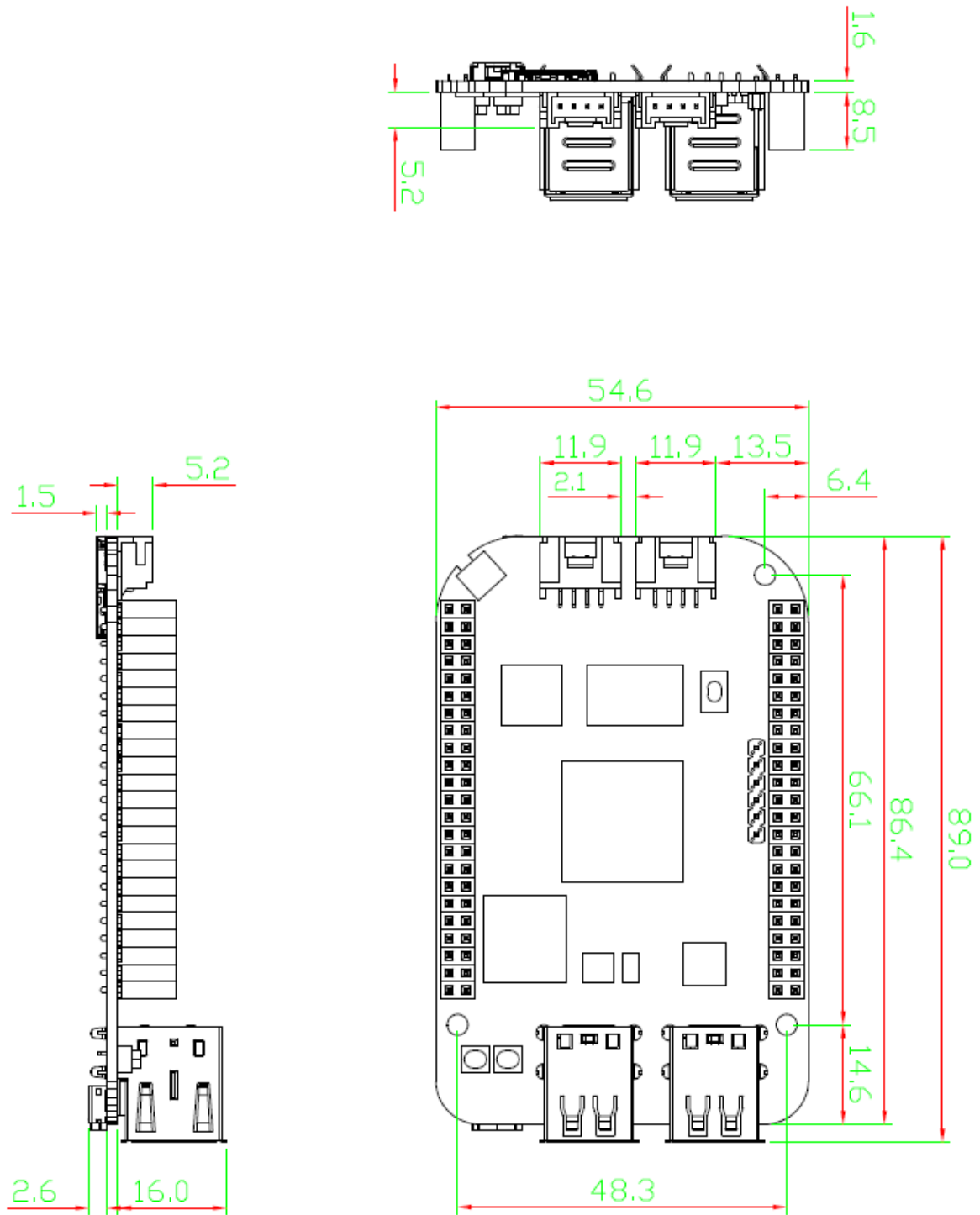

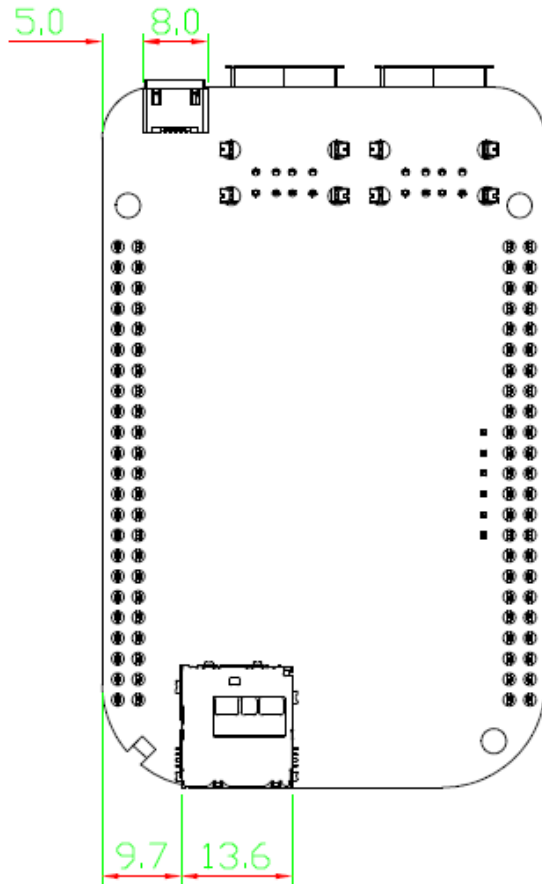
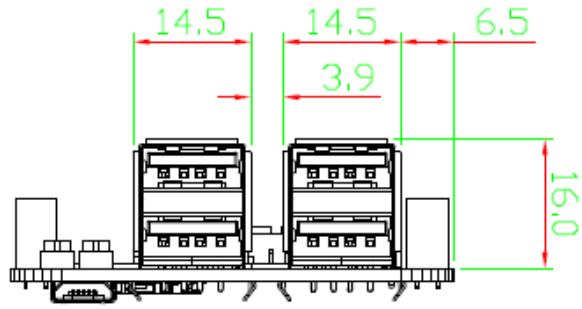

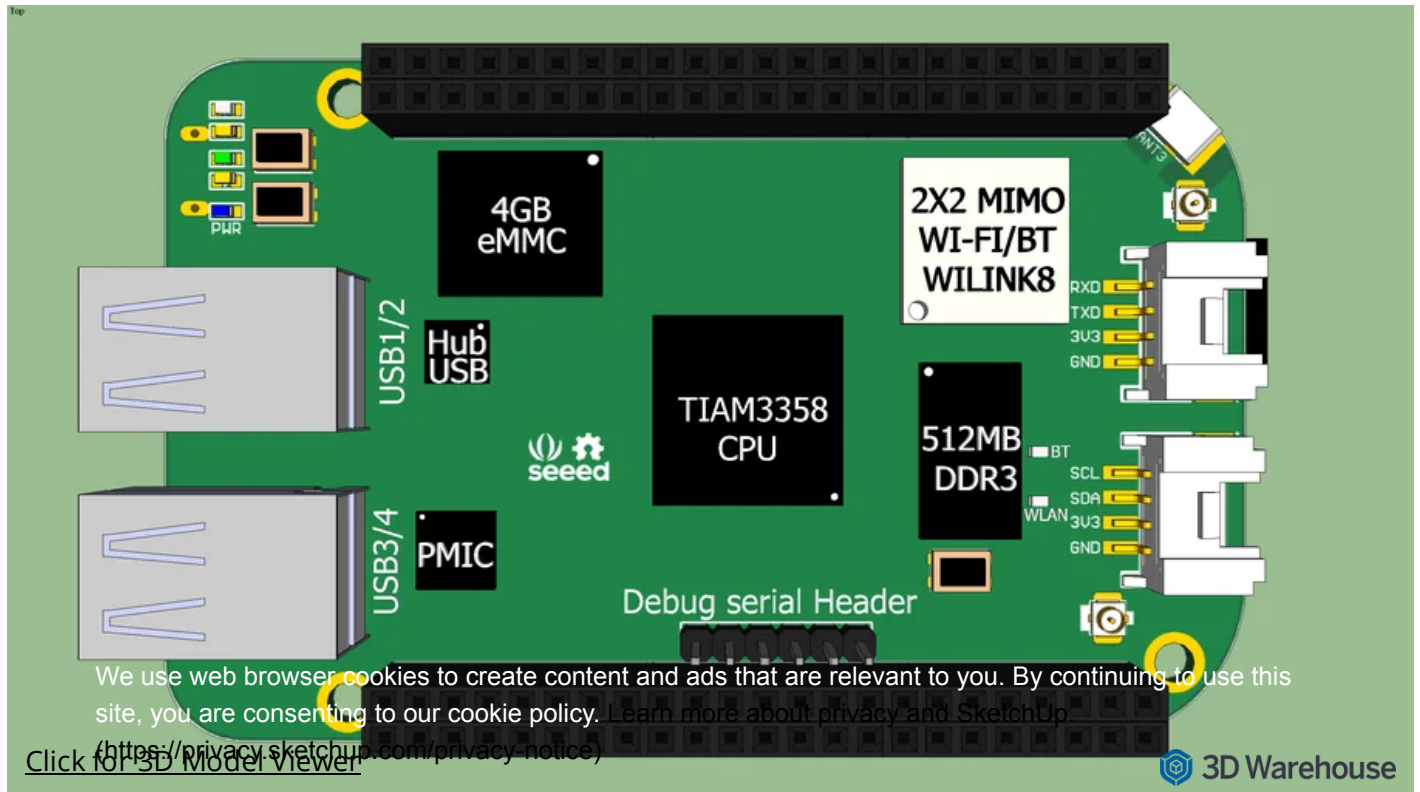

## Getting Started

This chapter is writing under Win10. The steps are familiar for the other operate systems.

### STEP1. Plug in your Seedeed Studio BeagleBone® Green Wireless via USB

Use the provided micro USB cable to plug your Seedeed Studio BeagleBone® Green Wireless into your computer. This will both power the board and provide a development interface. Seedeed Studio BeagleBone® Green Wireless will boot Linux from the **on-board 2GB** or 4GB eMMC.

Seedeed Studio BeagleBone® Green Wireless will operate as a flash drive providing you with a local copy of the documentation and drivers. Note that this interface may not be used to re-configure the microSD card with a new image, but may be used to update the boot parameters using the uEnv.txt file.

You'll see the PWR LED lit steadily. Within 10 seconds, you should see the other LEDs blinking in their default configurations.

- D2 is configured at boot to blink in a heartbeat pattern
- D3 is configured at boot to light during microSD card accesses
- D4 is configured at boot to light during CPU activity
- D5 is configured at boot to light during eMMC accesses

### STEP2. Install Drivers

Install the drivers for your operating system to give you network-over-USB access to your Beagle. Additional drivers give you serial access to your board.

Operating System	USB Drivers	Comments
Windows (64-bit)	<a href="#">64-bit installer</a>	
Windows (32-bit)	<a href="#">32-bit installer</a>	
Mac OS X	<a href="#">Network Serial</a>	Install both sets of drivers.



Operating System	USB Drivers	Comments
Linux	<a href="#">mkudevrule.sh</a>	Driver installation isn't required, but you might find a few udev rules helpful.

For window system, please note that:

- Windows Driver Certification warning may pop up two or three times. Click "Ignore", "Install" or "Run"
- To check if you're running 32 or 64-bit Windows see [this](#).
- On systems without the latest service release, you may get an error (0xc000007b). In that case, please [install](#) and retry:
- You may need to reboot Windows.
- These drivers have been tested to work up to Windows 10

### STEP3. Browse to your Beagle

Using either Chrome or Firefox (Internet Explorer will NOT work), browse to the web server running on your board. It will load a presentation showing you the capabilities of the board. Use the arrow keys on your keyboard to navigate the presentation.

Click <http://192.168.7.2> to launch to your Seeed Studio BeagleBone® Green Wireless. Older software images require you to EJECT the BeagleBone® drive to start the network. With the latest software image, that step is no longer required.

The screenshot shows the BeagleBoard.org website interface. At the top, there's a navigation bar with the logo and social media links. A green notification box at the top center says "Your board is connected! BeagleBone Green S/N BBG115070062 running BoneScript 0.2.4 at beaglebone.local" with "Run" and "Disconnect" buttons. Below this, the main content area features a "BeagleBone: open-hardware expandable computer" section with a grid of images and a list of features. On the left, there's a sidebar menu with categories like "Software", "Hardware", "BoneScript", "JavaScript", "Libraries", and "Demos".

### STEP4. Cloud9 IDE

To begin editing programs that live on your board, you can use the Cloud9 IDE by click

Open Cloud9 IDE of BBG

### STEP5. Connect your Seeed Studio BeagleBone® Green Wireless to Wi-Fi

Using your smart phone or computer to scan local Wi-Fi network and connect to the AP named "BeagleBone® XXX"

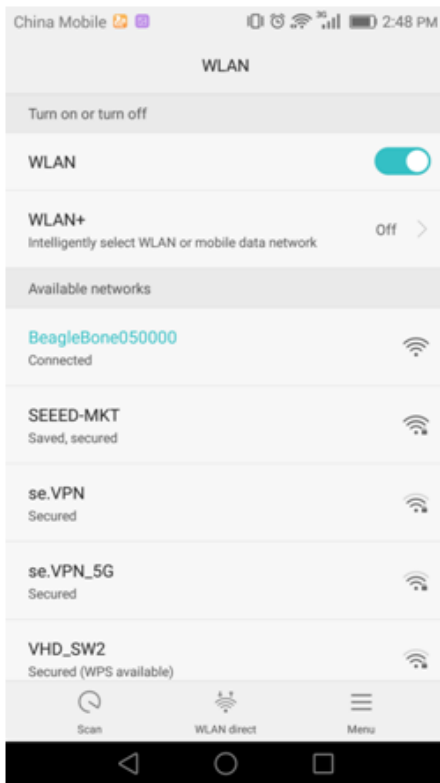

After connection succeeded, it will head to the login page automatically. Select the SSID of your Wi-Fi and enter the passwd, click OK.

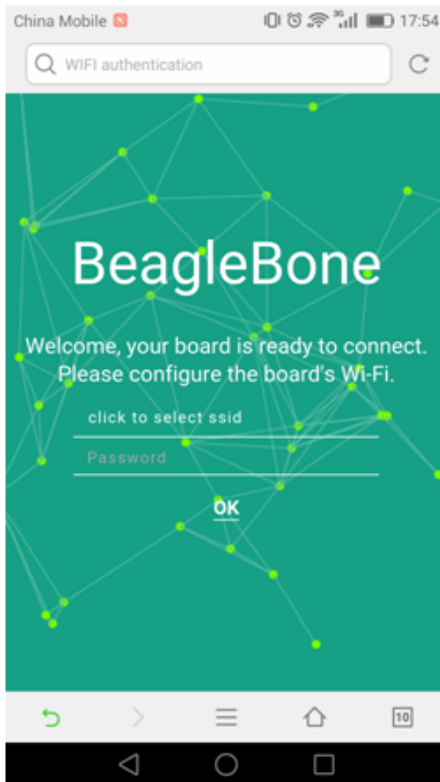

Now your Seed Studio BeagleBone® Green Wireless is connected to Wi-Fi.

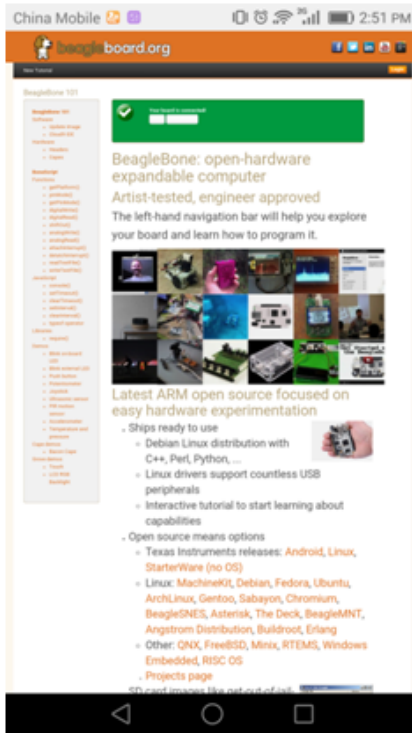

## STEP6. Connect your Seead Studio BeagleBone® Green Wireless to your Bluetooth Device

Connect to Cloud9 IDE and start a new terminal. Start the bluetooth config with the command:

```
bb-wl18xx-bluetooth
bluetoothctl
```

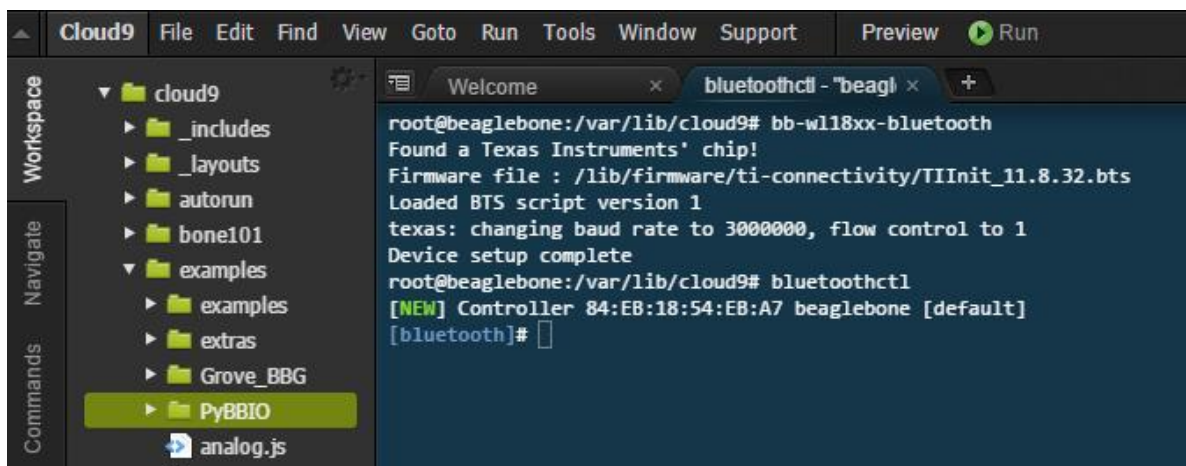

Type `scan on` to scan local bluetooth devices. My device named "jy" is found.

```
[bluetooth]# scan on
Discovery started
[CHG] Controller 84:EB:18:54:EB:A7 Discovering: yes
[NEW] Device 00:11:11:11:11:07 LAPTOP-Q2IJ7NUQ
[NEW] Device 10:00:00:00:00:0A 红米手机
[NEW] Device 0C:00:00:00:00:0B 0C-00000000-0B
[NEW] Device 49:00:00:00:00:47 49-F0000000-47
[CHG] Device 10:00:00:00:00:0A RSSI: -79
[CHG] Device 0C:00:00:00:00:0B RSSI: -59
[CHG] Device 0C:00:00:00:00:0B Name: jy
[CHG] Device 0C:00:00:00:00:0B Alias: jy
[CHG] Device 0C:00:00:00:00:0B UUIDs:
00001200-00000000-00000000-00000000
0000111f-00000000-00000000-00000000
0000112f-00000000-00000000-00000000
0000110a-00000000-00000000-00000000
0000110c-00000000-00000000-00000000
00001132-00000000-00000000-00000000
00000000-00000000-00000000-00000000
2d8d2466-00000000-00000000-00000000
[NEW] Device 00:11:11:11:11:C6 E3
[bluetooth]#
```

Copy the device mac address, then connect to the device with the command:

```
pair 0C:xx:xx:xx:xx:xx:0B
trust 0C:xx:xx:xx:xx:xx:0B
connect 0C:xx:xx:xx:xx:xx:0B
```

```
[bluetooth]# pair 0C:00:00:00:00:0B
Attempting to pair with 0C:00:00:00:00:0B
[CHG] Device 0C:00:00:00:00:0B Connected: yes
[CHG] Device 0C:00:00:00:00:0B Modalias: bluetooth:v004Cp6F02d0930
[CHG] Device 0C:00:00:00:00:0B UUIDs:
00000000-00000000-00000000-00000000
00001000-00000000-00000000-00000000
0000110a-00000000-00000000-00000000
0000110c-00000000-00000000-00000000
0000110e-00000000-00000000-00000000
00001116-00000000-00000000-00000000
0000111f-00000000-00000000-00000000
0000112f-00000000-00000000-00000000
00001132-00000000-00000000-00000000
00001200-00000000-00000000-00000000
[CHG] Device 0C:00:00:00:00:0B Paired: yes
Pairing successful
[CHG] Device 0C:00:00:00:00:0B Connected: no

[bluetooth]# trust 0C:00:00:00:00:0B
[CHG] Device 0C:00:00:00:00:0B Trusted: yes
Changing 0C:00:00:00:00:0B trust succeeded
[bluetooth]# connect 0C:00:00:00:00:0B
Attempting to connect to 0C:00:00:00:00:0B
[CHG] Device 0C:00:00:00:00:0B Connected: yes
Connection successful
```

Now your Seeed Studio BeagleBone® Green Wireless is connected to your bluetooth device. Type `quit` back to the terminal. Play music on Seeed Studio BeagleBone® Green Wireless, then you will hear music on your bluetooth speaker device.

## Update to latest software

You need to update the board to latest software to keep a better performance, here we will show you how to make it step by step.

STEP1. Download the latest software image

First of all, you have to download the suitable image here.

## Download the latest image of BBGW

Due to sizing necessities, this download may take about 30 minutes or more.

The file you download will have an **.img.xz** extension. This is a compressed sector-by-sector image of the SD card.

### STEP2. Install compression utility and decompress the image

Download and install [7-zip](#).

Choose a version that suitable for your system.

Use 7-zip to decompress the SD card **.img file**

### STEP3. Install SD card programming utility

Download and install [Image Writer for Windows](#). Be sure to download the binary distribution.

### STEP4. Write the image to your SD card

You need a SD adapter to connect your microSD card to your computer at the first. Then use the software Image Write for Windows to write the decompressed image to your SD card.

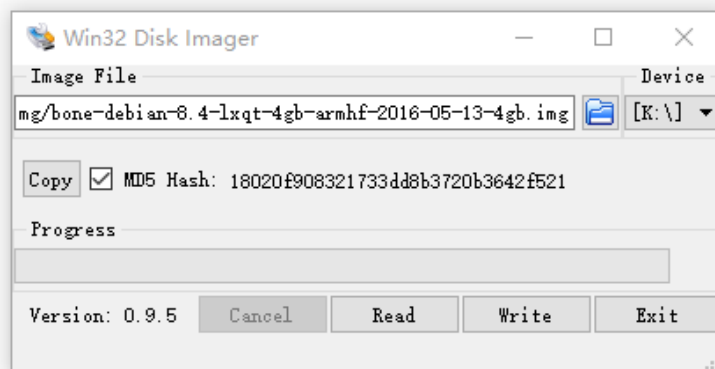

Click on **Write** button, then the process is started.

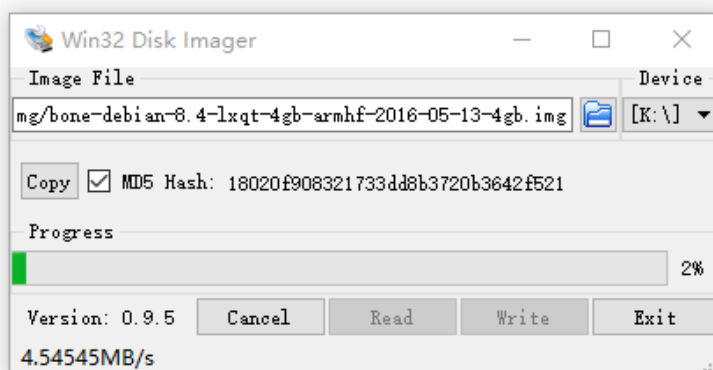

- You may see a warning about damaging your device. This is fine to accept as long as you are pointing to your SD card for writing.



- You should not have your BeagleBone® connected to your computer at this time.
- This process may need up to 10 minutes.

## STEP5. Boot your board off of the SD card

Insert SD card into your (powered-down first) board. Then the board will boot from the SD card.

If you don't need to write the image to your on-board eMMC, you don't need to read the last of this chapter. Otherwise please go ahead.

If you desire to write the image to your on-board eMMC, you need to launch to the board, and modify a file.

In `/boot/uEnv.txt`:

```
##enable Generic eMMC Flasher:
##make sure, these tools are installed: dosfstools rsync
#cmdline=init=/opt/scripts/tools/eMMC/init-eMMC-flasher-v3.sh
```

Change to:

```
##enable Generic eMMC Flasher:
##make sure, these tools are installed: dosfstools rsync
cmdline=init=/opt/scripts/tools/eMMC/init-eMMC-flasher-v3.sh
```

Then you will find the 4 user led light as below:

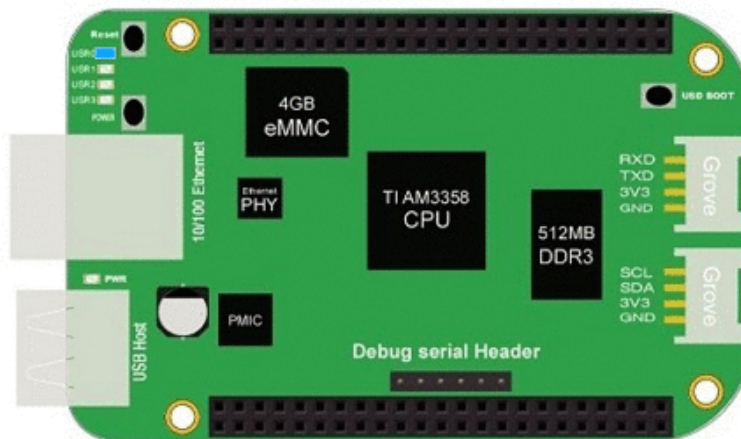

If you don't find the upper tracing light, please power down and power up the board.

When the flashing is complete, all 4 USRx LEDs will be **off**. The latest Debian flasher images automatically power down the board upon completion. This can take up to **10 minutes**. Power-down your board, remove the SD card and apply power again to be complete.

## Program Grove Module with Mraa and UPM

We have provided Mraa library and UPM library to make it easy for developers and sensor manufacturers to map their sensors & actuators on top of supported hardware and to allow control of low level communication protocol by high level languages & constructs.

What are Mraa and UPM?

Mraa is a C/C++ library with bindings to Python, Javascript and Java to interface with the I/O on Seeed Studio BeagleBone® Green, Seeed Studio BeagleBone® Green Wireless and other platforms, with a structured and sane API where port names/numbering matches the board that you are on. Use of Mraa does not tie you to specific hardware with board detection done at runtime you can create portable code that will work across the supported platforms. UPM is a high level repository for sensors that use MRAA. Each sensor links to MRAA and are not meant to be interlinked although some groups of sensors may be. Each sensor contains a header which allows to interface with it. Typically a sensor is represented as a class and instantiated. The constructor is expected to initialise the sensor and parameters may be used to provide identification/pin location on the board.

## Install and update

Mraa and UPM are already installed in the system image of Seeed Studio BeagleBone® Green Wireless, so **you don't need to install it**. However if you want to update the library, or want to upgrade the library, use `apt-get update` and `apt-get upgrade` please. Refer to <https://github.com/intel-iot-devkit/mraa> and <https://github.com/intel-iot-devkit/upm> for more information.

## Mraa Example

- light a led

```
import mraa
import time
#mraa.gpio60 = P9_14 = GPIO_50
led = mraa.Gpio(60)
led.dir(mraa.DIR_OUT)

while True:
    led.write(1)
    time.sleep(1)
    led.write(0)
    time.sleep(1)
```

- Grove - PIR Sensor

```
import mraa
import time
#mraa.gpio73 = P9_27 = GPIO_115
pir = mraa.Gpio(73)
pir.dir(mraa.DIR_IN)

while True:
    print (pir.read())
    time.sleep(1)
```

- Grove - Rotary Angle Sensor

```
import mraa
import time
#mraa.aiol = AIN0
rotary = mraa.Aio(1)

while True:
```

```
print(rotary.read())
time.sleep(1)
```

- [More Tutorials](#)

[Grove - 3-Axis Digital Accelerometer\(±16g\)](#) [Grove - Variable Color LED](#)

[Grove - Mini Fan](#) [Grove - PIR Motion Sensor](#) [Grove - Rotary Angle Sensor](#)

[Grove - Relay](#) [Grove - Sound Sensor](#)

[Grove - OLED Display 0.96"](#) [Grove - Light Sensor](#) [Grove - Temperature Sensor](#)

[Grove - GPS](#) [Grove - Button\(P\)](#) [Grove - Buzzer](#) [Grove - RTC v2.0](#)

Mraa Map for Seeed Studio BeagleBone® Green Wireless

BBGW Mraa Gpio					
Mraa	phy	GPIO	Mraa	phy	GPIO
7	P8_07	GPIO_66	42	P8_42	GPIO_75
8	P8_08	GPIO_67	43	P8_43	GPIO_72
9	P8_09	GPIO_69	44	P8_44	GPIO_73
10	P8_10	GPIO_68	45	P8_45	GPIO_70
13	P8_13	GPIO_23	46	P8_46	GPIO_71
19	P8_19	GPIO_22	57	P9_11	GPIO_30
27	P8_27	GPIO_86	59	P9_13	GPIO_31
28	P8_28	GPIO_88	60	P9_14	GPIO_50
29	P8_29	GPIO_87	61	P9_15	GPIO_48
30	P8_30	GPIO_89	62	P9_16	GPIO_51
31	P8_31	GPIO_10	63	P9_17	GPIO_5
32	P8_32	GPIO_11	64	P9_18	GPIO_4
33	P8_33	GPIO_9	67	P9_21	GPIO_3
34	P8_34	GPIO_81	68	P9_22	GPIO_2
35	P8_35	GPIO_8	69	P9_23	GPIO_49
36	P8_36	GPIO_80	70	P9_24	GPIO_15
37	P8_37	GPIO_78	71	P9_25	GPIO_117
38	P8_38	GPIO_79	72	P9_26	GPIO_14
39	P8_39	GPIO_76	73	P9_27	GPIO_115
40	P8_40	GPIO_77	87	P9_41	GPIO_20
41	P8_41	GPIO_74	88	P9_42	GPIO_7

BBGW Mraa I2C			
Mraa	I2C	PIN	FUN
0	I2C1	P9_17	I2C1_SCL
		P9_18	I2C1_SDA
1	I2C2	P9_19	I2C2_SCL
		P9_20	I2C2_SDA

BBGW Mraa PWM		
Mraa	PWM	PIN
68	EHRPWM0A	P9_22
67	EHRPWM0B	P9_21
36 60	EHRPWM1A	P8_36 P9_14
62 34	EHRPWM1B	P9_16 P8_34
19 45	EHRPWM2A	P8_19 P8_45
13 46	EHRPWM2B	P8_13 P8_46
88	ECAPPWM0	P9_42

BBGW Mraa ADC	
Mraa	ADC
1	AIN0
2	AIN1
3	AIN2
4	AIN3
5	AIN4
6	AIN5
7	AIN6

BBGW Mraa UART				
MRAA	PIN	FUN	UART	DEV
0	P9_24	UART1_TXD	UART1	/dev/ttyO1
	P9_26	UART1_RXD		
1	P9_21	UART2_TXD	UART2	/dev/ttyO2
	P9_22	UART2_RXD		
2			UART3	/dev/ttyO3
3	P9_13	UART4_TXD	UART4	/dev/ttyO4
	P9_11	UART4_RXD		
4	P8_37	UART5_TXD+	UART5	/dev/ttyO5
	P8_38	UART5_RXD+		

## Grove for Seeed Studio BeagleBone® Green

Grove is a modular, standardized connector prototyping system. Grove takes a building block approach to assembling electronics. Compared to the jumper or solder based system, it is easier to connect, experiment and build and simplifies the learning system, but not to the point where it becomes dumbed down. Some of the other prototype systems out there takes the level down to building blocks. Good stuff to be learned that way, but the Grove system allows you to build real systems. It requires some learning and expertise to hook things up.

Below listed the Grove modules that work well with Seeed Studio BeagleBone® Green.

SKU	Name	Interface	link
101020054	Grove - 3-Axis Digital Accelerometer(+16g)	I2C	<a href="#">link</a>
101020071	Grove - 3-Axis Digital Accelerometer(+400g)	I2C	<a href="#">link</a>
101020034	Grove - 3-Axis Digital Compass	I2C	<a href="#">link</a>

SKU	Name	Interface	link
101020050	Grove - 3-Axis Digital Gyro	Analog	<a href="#">link</a>
101020081	Grove - 6-Axis Accelerometer&Compass v2.0	I2C	<a href="#">link</a>
101020072	Grove - Barometer Sensor(BMP180)	I2C	<a href="#">link</a>
104030010	Grove - Blue LED	I/O	<a href="#">link</a>
101020003	Grove - Button	I/O	<a href="#">link</a>
111020000	Grove - Button(P)	I/O	<a href="#">link</a>
107020000	Grove - Buzzer	I/O	<a href="#">link</a>
104030006	Grove - Chainable RGB LED	I2C	<a href="#">link</a>
101020030	Grove - Digital Light Sensor	I2C	<a href="#">link</a>
103020024	Grove - Finger-clip Heart Rate Sensor	I2C	<a href="#">link</a>
101020082	Grove - Finger-clip Heart Rate Sensor with shell	I2C	<a href="#">link</a>
113020003	Grove - GPS	UART	<a href="#">link</a>
104030007	Grove - Green LED	I/O	<a href="#">link</a>
103020013	Grove - I2C ADC	I2C	<a href="#">link</a>
103020006	Grove - I2C Hub	I2C	<a href="#">link</a>
101020079	Grove - IMU 10DOF	I2C	<a href="#">link</a>
101020080	Grove - IMU 9DOF v2.0	I2C	<a href="#">link</a>
101020040	Grove - IR Distance Interrupter	I/O	<a href="#">link</a>
104030011	Grove - OLED Display 0.96"	I2C	<a href="#">link</a>
104030008	Grove - OLED Display 1.12"	I2C	<a href="#">link</a>
104030005	Grove - Red LED	I/O	<a href="#">link</a>
103020005	Grove - Relay	I/O	<a href="#">link</a>
316010005	Grove - Servo	I/O	<a href="#">link</a>
101020023	Grove - Sound Sensor	Analog	<a href="#">link</a>
101020004	Grove - Switch(P)	I/O	<a href="#">link</a>
101020015	Grove - Temperature Sensor	Analog	<a href="#">link</a>
101020019	Grove - Temperature&Humidity Sensor Pro	Analog	<a href="#">link</a>

## Cape for Seeed Studio BeagleBone® Green

You will need some expansion board when you start a project. There're many cape for Seeed Studio BeagleBone® Green already, they include LCD display, motor driver as well as HDMI expansion etc. Below is some of them recommend.

**Grove Cape**

**Motor Bridge Cape**

**HDMI Cape**



**Grove Cape**[GET ONE NOW!](#)**Grove Cape****Motor Bridge Cape**[GET ONE NOW!](#)**5 Inch LCD****HDMI Cape**[GET ONE NOW!](#)**7 Inch LCD**[GET ONE NOW!](#)[GET ONE NOW!](#)[GET ONE NOW!](#)

## References

There're many references to help you to get more information about the board.

- [BeagleBoard Main Page](#)
- [Seeed Studio BeagleBone® Green Wireless info at BeagleBoard page](#)
- [BeagleBoard Getting Started](#)
- [Troubleshooting](#)
- [Hardware documentation](#)
- [Projects of BeagleBoard](#)

## FAQs

**Q1: How to connect your Seeed Studio BeagleBone® Green Wireless to your Bluetooth Device with Debian 9.5 2018-10-07 4GB image?**

**A1:** Please follow below instructions. thanks.

```

udebian@beaglebone:~$ uname -a
Linux beaglebone 4.14.71-ti-r80 #1 SMP PREEMPT Fri Oct 5 23:50:11 UTC 2018 armv7l
GNU/Linux
debian@beaglebone:~$ bluetoothctl --agent
[NEW] Controller A4:D5:78:6D:6F:E0 beaglebone [default]
Agent registered
[bluetooth]# scan on
Discovery started
[CHG] Controller A4:D5:78:6D:6F:E0 Discovering: yes
[NEW] Device C0:72:BC:0A:E6:1E HB7910703602
[NEW] Device E8:19:C4:6B:03:5C YONGNUO LED
[NEW] Device C0:F6:1E:02:0A:1E HB7690138998

```

## Resources

- [PDF] [Seeed Studio BeagleBone® Green Wireless Schematic\(pdf\)](#)
- [Zip] [AM335X Datasheet](#)
- [3D] [Seeed Studio BeagleBone® Green Wireless 3D Model](#)
- [PDF] [Seeed Studio BeagleBone® Green Wireless Mechincal Drawing](#)

## Project

**Seeed Studio BeagleBone® Green Wireless Irrigation Control:** Seeed Studio BeagleBone® Green Wireless Irrigation Control using HTML5, WebSockets, and Ecmascript 6.

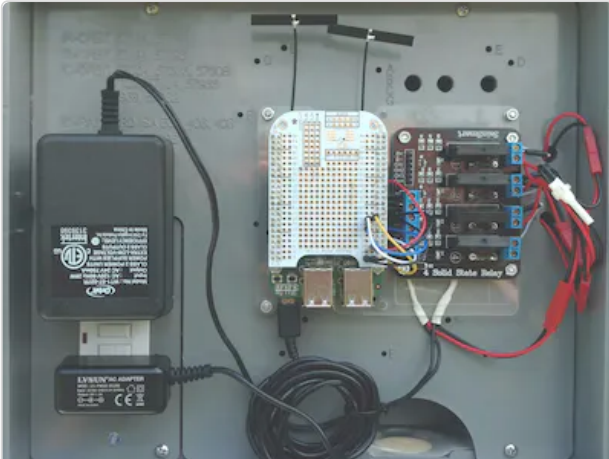

(<https://www.hackster.io/Greg-R/beaglebone-green-wireless-irrigation-control-ce7c4b>)

## Tech Support

Please submit any technical issue into our [forum](#) .