

PROCENTEC

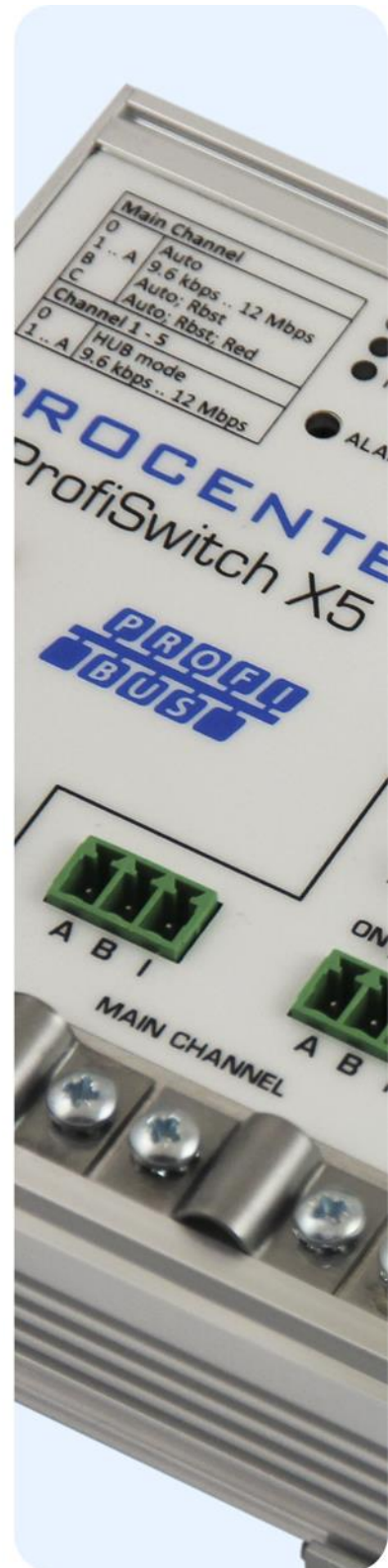
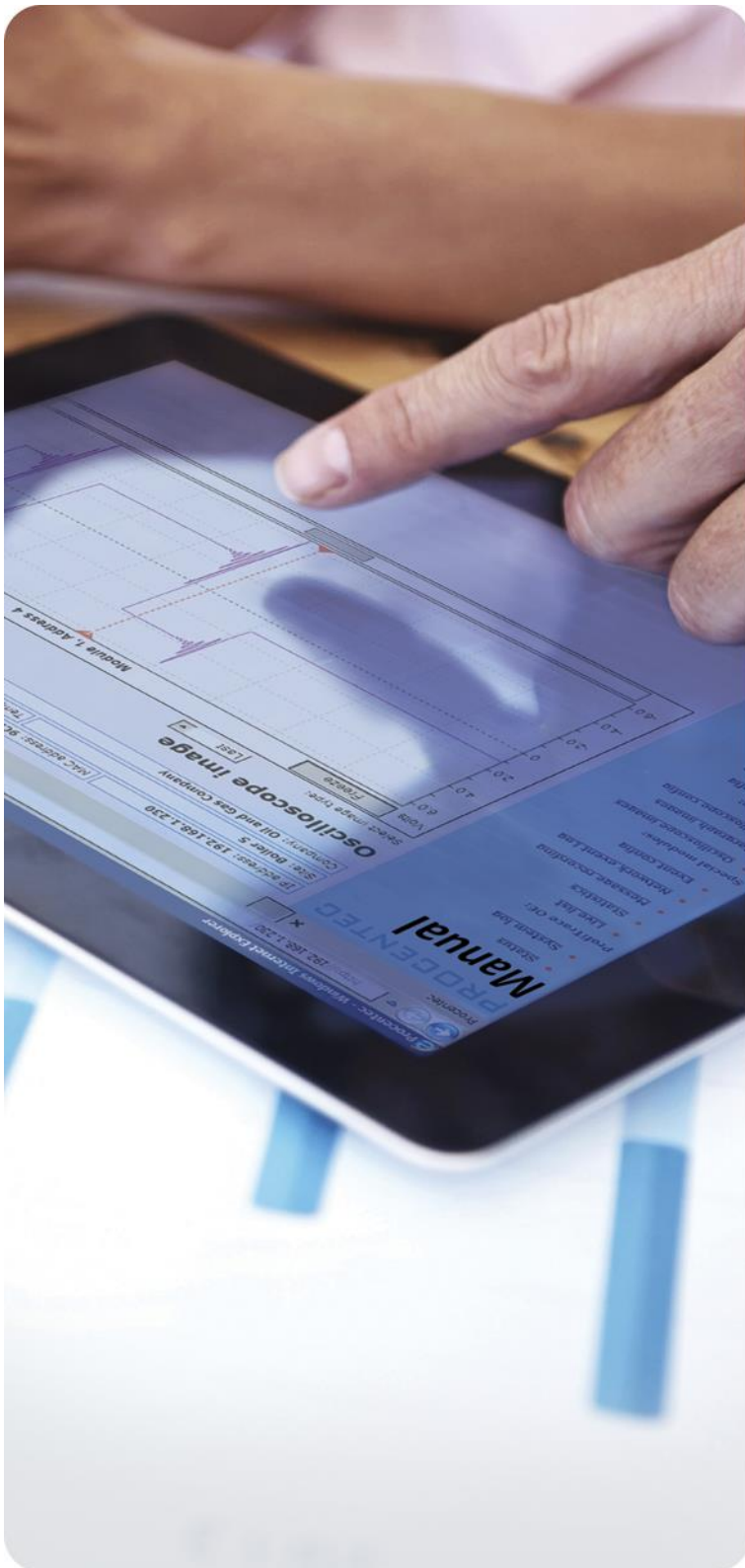

ProfiSwitch X5

User Manual

Copyright © 2017 PROCENTEC

All rights reserved. No part of this publication may be reproduced, stored in a retrieval system, or transmitted, in any form or by any means, electronic, mechanical, photocopying, recording or otherwise, without the prior written permission of the publisher.

Safety Guidelines

This manual contains notices which you should observe to ensure your own personal safety, as well as to protect the product and connected equipment. These notices are highlighted in the manual by a warning sign and are marked as follows according to the level of danger:



Draws your attention to important information on handling the product, a particular part of the documentation or the correct functioning of the product.

Warning

This device and its components may only be used for the applications described in this manual and only in connection with devices or components that comply with PROFIBUS and an RS 485 interface. This product can only function correctly and safely if it is transported, stored, set up, installed, operated and maintained as recommended.

Qualified Technicians

Only qualified technicians should be allowed to install and work with this equipment. Qualified technicians are defined as persons who are authorized to commission, to ground, to tag circuits and systems in accordance with established safety practices and standards. It is recommended that the technicians carry a Certified PROFIBUS Installer or Certified PROFIBUS Engineer certificate.

Disclaimer of Liability

We have checked the contents of this manual as much as possible. Since deviations cannot be precluded entirely, we cannot guarantee full agreement. However, the content in this manual is reviewed regularly and any necessary corrections included in subsequent editions. Suggestions for improvement are welcomed.

Important information

Purpose of the Manual

This manual explains how to put the ProfiSwitch X5 into operation.

Recycling and Disposal

The parts of the ProfiSwitch can be recycled. For further information about environment-friendly recycling and the procedure for disposing of your old equipment, please contact:

PROCENTEC
Klopperman 16
2292 JD WATERINGEN
The Netherlands

Tel.: +31-(0)174-671800
Fax: +31-(0)174-671801
Email: info@procentec.com

Document Updates

You can obtain constantly updated information on PROCENTEC products on the Internet at www.procentec.com. You can also contact PROCENTEC Customer Support:

- By phone at +31-(0)174-671800
- By fax at +31-(0)174-671801
- By email at support@procentec.com

Contents

Important information	2
1. Product description	5
1.1 ProfiSwitch X5 introduction	5
1.2 Product features.....	6
1.3 Application areas.....	6
1.4 Additional benefits.....	6
1.5 Channel Structure	7
1.6 Grounding System	8
1.7 Cable lengths for PROFIBUS DP.....	9
1.8 Cable types for PROFIBUS DP.....	9
1.9 Status LEDs	10
2. Installation Instructions ProfiSwitch X5.....	11
2.1 Location.....	11
2.2 Position.....	11
2.3 Mounting.....	11
2.4 Power Supply.....	12
2.5 Grounding of the power.....	13
2.6 Alarm contact.....	13
2.7 Main Channel	14
2.8 Channels 1 - 5.....	14
2.8.1 Pin layout of the screw terminals:	14
2.8.2 Testing.....	14
2.8.3 Masters and slaves on Channel 1 – 5	15
2.8.4 Busparameters	15
2.8.5 Watchdog.....	15
2.8.6 Timing.....	16
2.9 Baudrate switches	16
2.10 Termination.....	17
2.11 Robust Repeating mode.....	17
2.12 Channel Redundancy.....	17
3. Technical Data ProfiSwitch X5	19
4. Sales offices and distributors.....	21
5. Order codes	26

- 6. Glossary 27
- 7. About PROCENTEC 30
- 8. Certificates 31
- 9. Revision history 34
- 10. Notes 35

1. Product description

1.1 ProfiSwitch X5 introduction

The ProfiSwitch X5 modernizes PROFIBUS network architecture for the next generation. The transparent repeater hub has the ability to create baudrate customization per channel. A simple rotary switch opens doors to a new landscape with reliable and money saving applications.

The X5 eliminates traditional PROFIBUS network baudrate constraints associated with spur lines, additional resistance, single master systems, poor cable segments and cable length limitations. Design limitations associated with legacy systems or new built systems are eliminated, creating the capability for unprecedented customizable network designs. One main PLC can now act as a workhorse with the ability to extend the network further, spur line hot swap, reduction of repeater installation, all without limiting speed performance. With limitless applications, the ProfiSwitch X5 will become your go to device for creating networks without traditional limitations.

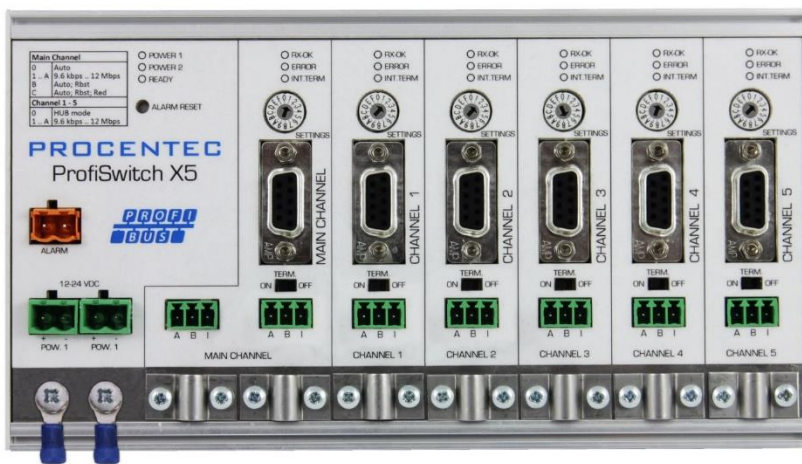

Figure 1 - ProfiSwitch X5

1.2 Product features

- Various baudrate distribution
- Faster cycle time
- Legacy host systems
- 9.6 kbps – 12 Mbps
- 5 isolated repeater channels
- Transparent for all PROFIBUS DP – protocols (DPV0 & DPV1 class 2)
- 31 devices per channel
- Integrated termination facilities
- Redundant power supply
- Switch contact for errors
- Configurable grounding system

1.3 Application areas

- Extend Network length, without sacrificing Baudrate speed.
- Adding to Legacy Systems with Fixed Baudrate limitations
- Media Coupling within 1 network with PA and wireless devices.
- Eliminate none traditional cabling limitations
- Bad Segment Isolation
- EMC interference reduction
- Reduce Resistance effects, i.e. lightning arrestors.
- Limited speed PROFIBUS devices, operating on high speed networks.

1.4 Additional benefits

- Cable length limitation removed
- One master for different network types
- No more design limits
- Cost saving
- Coupler to any PB device
- With one DCS system different busparameters can be used
- Suitable for all DP cables
- Short circuit protection on each channel
- Insertion and removal of slaves is possible during operation
- Faster update times
- Less repeaters

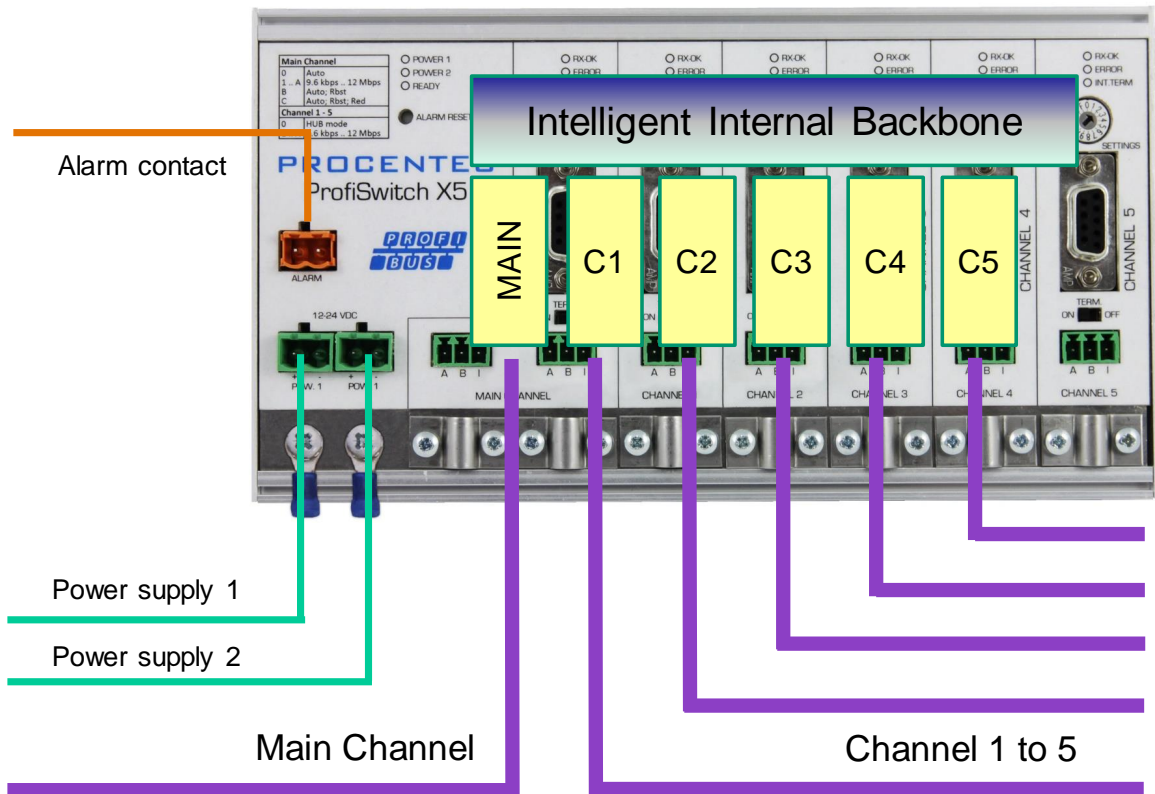

Figure 2 - Connections of the ProfiSwitch X5

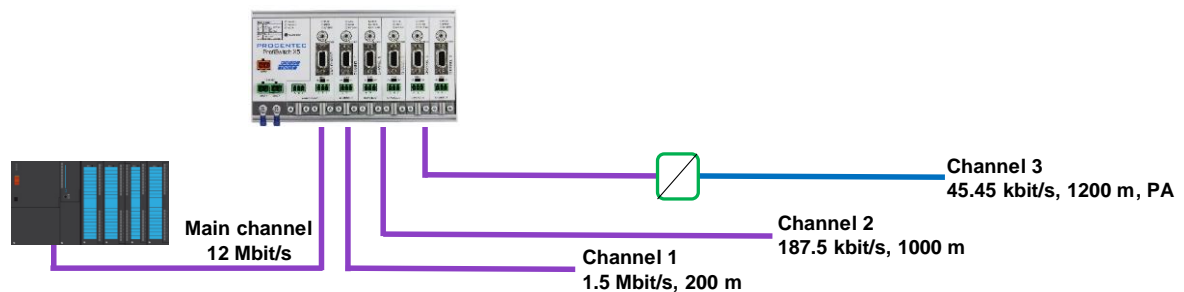

Figure 3 - Application example: One network, multiple baudrates, different cable lengths

1.5 Channel Structure

Each channel is electrically isolated and internally connected to the transparent intelligent backbone. Every channel has a rotary switch for easy setting of the baudrate. The termination is switchable and powered by the ProfiSwitch. The shield of the PROFIBUS cable can be directly grounded or indirectly grounded (see next paragraph).

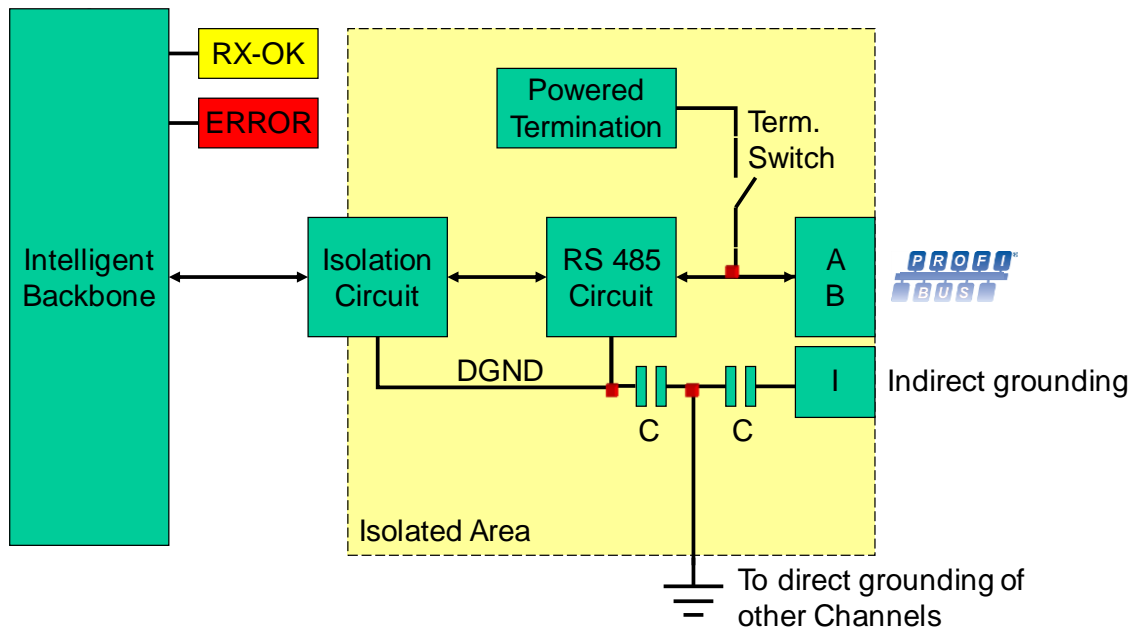

Figure 4 - Channel structure

1.6 Grounding System

The ProfiSwitch X5 can be grounded in 3 ways:

1. Direct grounding on the Ground Rail
2. Indirect grounding (through a capacitor)
3. Combination of direct and indirect.

The power supply must be grounded directly on the Ground Rail. The shielding of the PROFIBUS cables can be directly or indirectly grounded. If you do not want to ground all or some cables to the common ground, i.e. compensating current, the cable shielding must be connected to pin 'I' which stands for Indirect grounding. A capacitor with a parallel high value resistor will separate the 2 potentials (see Figure 4), ensuring protection of the signal against non-DC disturbances.

If by accident on 1 channel the Direct Grounding is connected with the Indirect Grounding, the connection to the Direct Grounding bypasses the capacitor in the Indirect Ground connection. The current on the shield will flow to Direct Ground.

1.7 Cable lengths for PROFIBUS DP

The cables on all Channels must comply with the PROFIBUS DP cable specifications for RS 485 (see Figure 5). Each channel may have its own baudrate and corresponding length.

Baudrate (kbps)	9.6	19.2	45.45	93.75	187.5	500	1500	3000	6000	12000
Segment length (m)	1200	1200	1200	1200	1000	400	200	100	100	100
Segment length (feet)	3940	3940	3940	3940	3280	1310	656	328	328	328

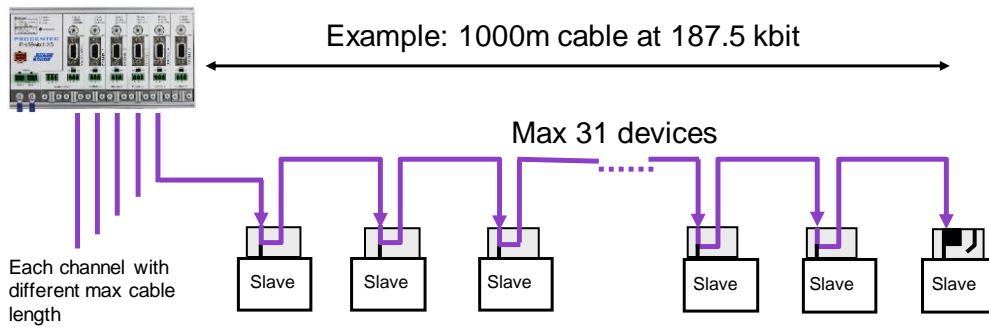

Figure 5 - PROFIBUS cable lengths and baudrates

1.8 Cable types for PROFIBUS DP

The cable type must comply with the PROFIBUS DP cable specifications for RS 485 (Fig. 7).

Parameter	Value
Wires	2 (twisted)
Impedance	135 .. 165 Ohm at 3 to 20 MHz
Capacity	< 30 pF/m
Loop resistance	< 110 Ohm/km
Wire diameter	> 0.64 mm
Wire area	> 0.32 mm ²

Fig. 7 – PROFIBUS DP cable specifications

The ProfiSwitch X5 can handle cables based on multiple protection sheaths with an overall cable diameter between 6 to 12 mm (Fig. 8).

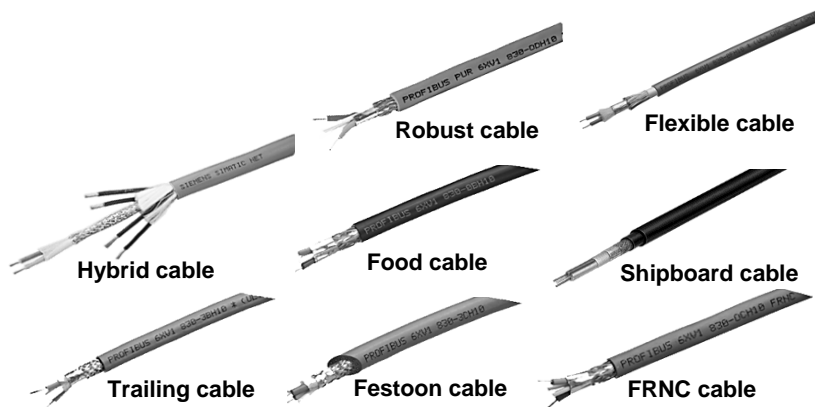

Fig. 8 – Cables with different protection sheaths

1.9 Status LEDs

The Status LEDs on the ProfiSwitch are very useful for diagnostics.

	OFF	Blinking	ON
POWER 1 / 2	☹️ Power is not switched on or an internal error	⚠️ Power supply not stable, redundant power supply interrupted or an internal failure	😊 Power supply OK
READY	☹️ Power is not switched on or an internal error	☹️ Trying to detect the transmission speed, but has not locked it yet	😊 The transmission speed has been detected
Channel RX-OK	☹️ There is no communication detected on this channel	😊 1 or more devices communicating on this channel	⚠️ Internal error
Channel ERROR	😊 No problem has been detected	⚠️ A problem in the cabling or telegram has been detected	⚠️ Problem in the cabling or telegram has been detected, or baudrate not detected
INT. TERM	Termination for this channel is OFF	⚠️ Internal error	Termination for this channel is ON

2. Installation Instructions ProfiSwitch X5

2.1 Location

The ProfiSwitch X5 can be installed everywhere in a non-hazardous area that complies with IP 20 (DIN 40 050) and the specified temperature range of -25 to +70° Celsius or -13 to +158° Fahrenheit.

2.2 Position

The ProfiSwitch X5 can be installed in every position, but it is recommended to install it with the cables pointing down. In this position it is also easier to read the status LEDs.

2.3 Mounting

The ProfiSwitch X5 can be mounted on 35 mm DIN-rail with a minimum width of 203 mm.

The supplied rubber studs need to be placed on the back of the housing of the ProfiSwitch X5 for extra fixation. This is to prevent the product to potentially slide off the DIN-rail. See Figure 6 for an example.



Figure 6 - Rubber studs on backside of housing

2.4 Power Supply

The two 2-pin screw type power connectors are located on the left of the ProfiSwitch X5 (Fig. 10).

- 1 = + (left)
- 2 = - (right)

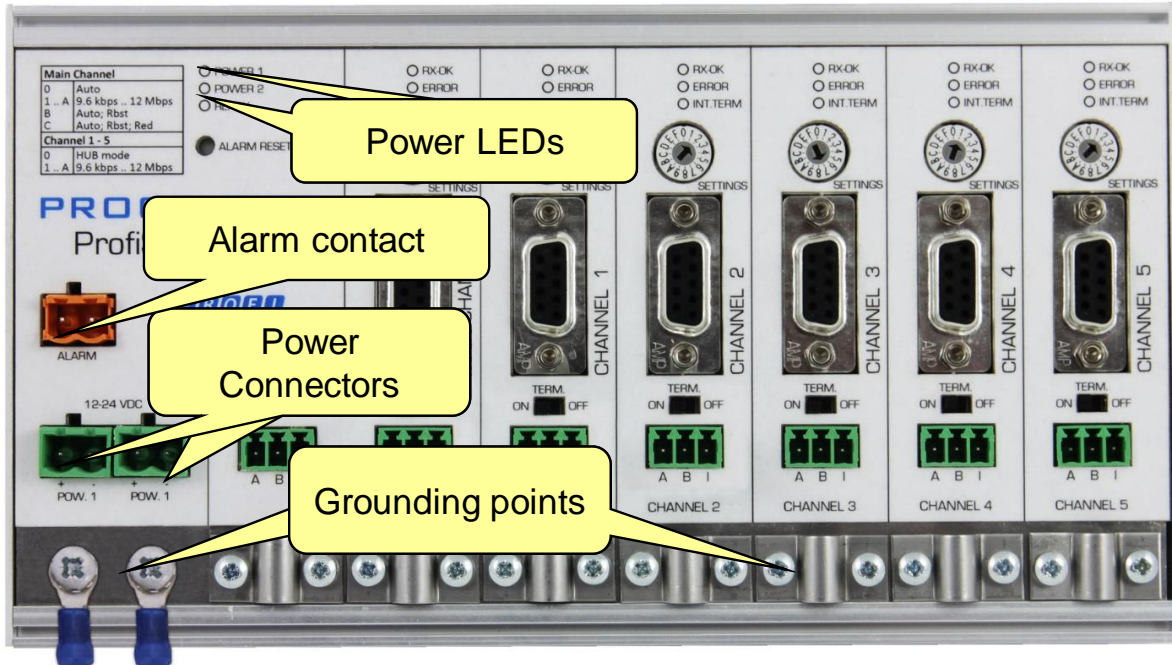

Figure 7 - Power connectors and LEDs

Both power connectors are linked 1-on-1 to the internal power supply of the ProfiSwitch. If one power supply fails, the other takes over without delay time. When redundancy is not required, it is sufficient to use one power connector. Please note that when using only one power supply, a voltage of max. 0.25 V will exist on the other unconnected power connector, like shown in Figure 8.

If only one power supply is used, the alarm contact is closed. If two power sources are connected, the contact is open. As soon as one of the power supplies fails, the contact will close and the Power Indicator LED will blink.

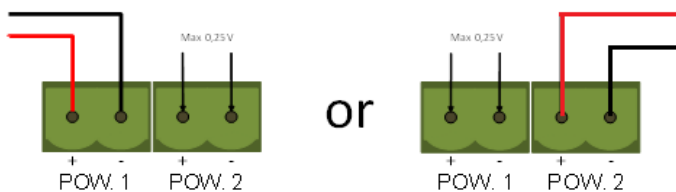

Figure 8 - Maximum voltage on unconnected Power Connector

The power supply must comply with the following specifications:

- Limited Power Source (LPS) or NEC Class 2 or CEC Class 2
- Voltage: **12 - 24 VDC**
- Current: **min 275 mA**
- Wire diameter: **< 2.5 mm²**

Procedure

To connect the 24V supply to the 2-pin screw-type terminal, proceed as follows:

- Strip the insulation from the cable or the conductors for the 24V power supply.
- Add cable crimp terminals/wire ferrules to the conductors.
- Secure the crimp terminals in the screw-type terminal.

To connect the power supply, you need a 3 mm screwdriver.

Testing:

If the power is switched on it can be diagnosed by the following indicators:

- LEDs should be blinking in a circular animation for a short time.
- The POWER LED of the respective power connector (1, 2 or both) is ON.
- The READY LED is ON or Blinking, depending on baud rate lock.

2.5 Grounding of the power



It is recommended to use a power supply with a ground lead (3-wire). Connect the ground lead of the power lead to the Ground Rail of the ProfiSwitch X5. Connect the Ground Rail to the common ground with a separate ground lead. See Fig. 12 for an example.

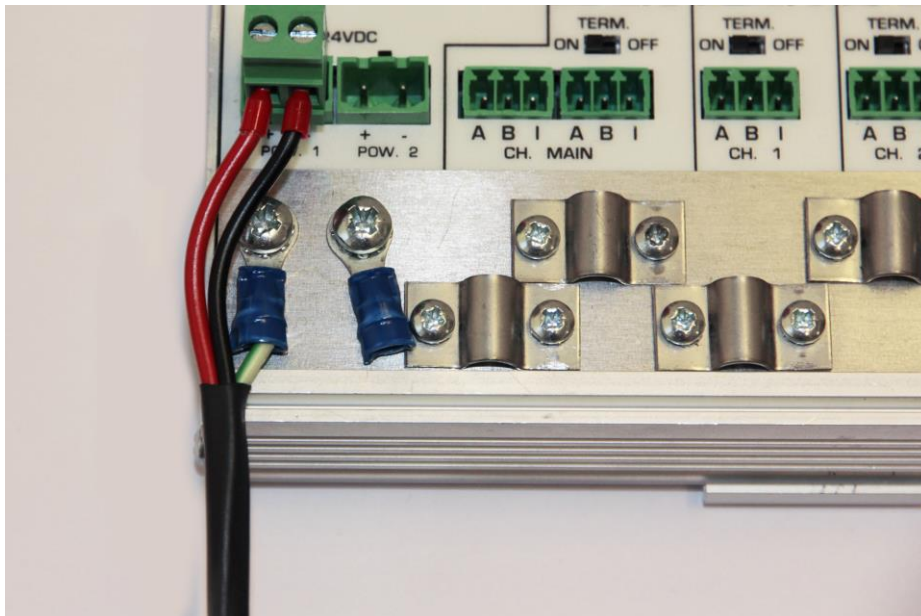

Fig. 12 – Connection to Ground Rail

2.6 Alarm contact

The ProfiSwitch X5 features a potential-free relay contact. This alarm contact can be used to monitor the power supplies. Example applications are: Connect a LED tower, alarm buzzer, SMS server or use it as a digital signal for the PLC.

If only one power supply is used, the alarm contact is closed. If two power sources are connected, the contact is open. As soon as one of the power supplies fails, the contact will close and the Power Indicator LED will blink.

In the case of an interrupted power supply you can reset the contact by pressing the 'Reset' button. The contact will open and the LEDs will stop blinking.

The maximum power to be connected to the alarm contact is 24 VDC. The maximum switching current is 500 mA.

2.7 Main Channel

The PLC or DCS system(s) must be connected to the Main Channel. The rotary switch of this Channel must be set to the same baud rate as the master, or you can set it to 'Auto-Detect' (position 0). The options 'Robust' or 'Redundant' are also available (rotary setting B or C). For a description of these settings see paragraph 2.11 and 2.12.

You can connect up to 31 PROFIBUS nodes to the Main Channel.

2.8 Channels 1 - 5

Connect the spur segments to the connectors of Channel 1 to 5 (Fig. 14). The second method is to place a PROFIBUS standardized plug on the DB9 connector of the specific Channel.

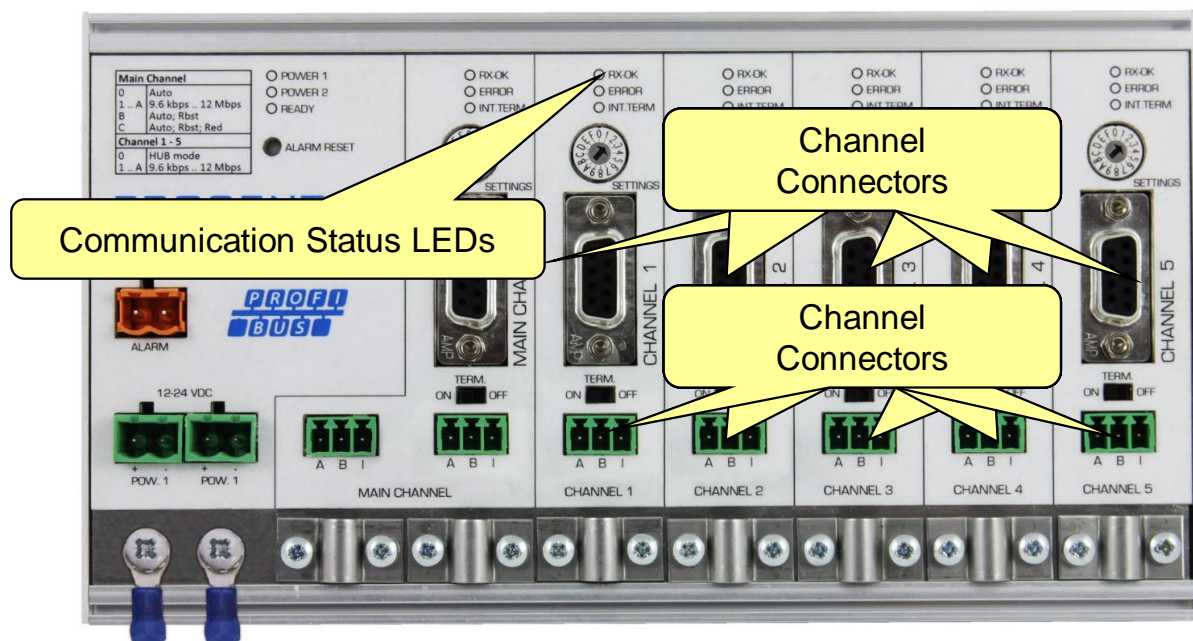

Figure 9 - PROFIBUS DP spur connectors

2.8.1 Pin layout of the screw terminals:

Pin "A": Green wire

Pin "B": Red wire

Pin "I": Indirect cable shielding, for reducing EMC and noise in demanding areas

Note: Connecting the Indirect cable shielding is not required when the ground clips are used.

2.8.2 Testing

If a Channel recognizes valid PROFIBUS messages from one or more connected devices, the RXOK LED of the Channel should be blinking.

2.8.3 Masters and slaves on Channel 1 – 5

The PLC or DCS system(s) must be connected to the Main Channel. If a Channel 1 – 5 is in Hub mode, this channel will be fully transparent for other masters as well. If a Channel is on a different baudrate than the main channel, you can connect a master to that channel, but your master will only be able to communicate on that channel only.

The use of address 1 for masters and/or slaves is not possible for channels 1 to 5.

You can connect up to 31 PROFIBUS nodes to a Channel.

2.8.4 Busparameters

The ProfiSwitch uses a set of busparameters for each Channel 1 to 5. The busparameters depend on the selected baudrate. See Table 1 for a complete overview of used busparameters.

Table 1 - Busparameters used by ProfiSwitch for Channels 1 - 5

	9.6 kbps	19.2 kbps	45.45 kbps	93.75 kbps	187.5 kbps	500 kbps	1.5 Mbps	3 Mbps	6 Mbps	12 Mbps
Retries	5	5	5	5	5	5	5	5	5	5
Tslot	100	100	640	2500	100	200	300	400	600	1000
MinTSDR	11	11	11	11	11	11	11	11	11	11
Ttr	800000	800000	800000	800000	800000	800000	800000	800000	800000	800000
Tquiet	1	1	1	1	1	1	1	1	6	9
Tid1	37	37	225	225	37	37	37	46	57	76
Tid2	60	60	400	1000	60	100	150	250	450	800
Tto	0	0	0	0	0	0	0	0	0	0
GAP	1	1	1	1	1	1	1	1	1	1
HSA	126	126	126	126	126	126	126	126	126	126

2.8.5 Watchdog

The Watchdog that is set in the master by the user, is automatically read by the ProfiSwitch. It uses the Watchdog parameter to calculate a new Watchdog for a Channel that is **not** in Hub mode.

The calculation is as follows: $WD_{channel} = WD_{main} \times \left(\frac{Baudrate_{main}}{Baudrate_{channel}} \right)$

Example situation:

- Watchdog in the PLC or DCS is set to 200 ms
- Baudrate in the PLC or DCS is set to 1.5 Mbps
- Baudrate on channel 1 is set to 93.75 kbps
- Baudrate on channel 2 is set to 500 kbps

Then the Watchdog on channel 1 is $200 \times (1500 / 93.75) = 3200$ ms

And the Watchdog on channel 2 is $200 \times (1500 / 500) = 600$ ms

If the baudrate on the main channel is much lower than on Channel 1 - 5, it might be possible that slaves do not enter Data Exchange due to a low Watchdog. In that case, increase the Watchdog in the PLC/DCS.

2.8.6 Timing

The ProfiSwitch X5 is not a fully transparent device; it uses a buffer between Channels if these Channels are not in Hub mode. This buffer can cause a delay in sending a telegram from one channel to the other. Channels 1 to 5 each have a master polling the slaves connected to that respective Channel. If a telegram from a PLC/DCS to slave x is sent to the master of a specific Channel, and the cycle of that master has just polled slave x, it will take a full cycle of that master before the telegram is sent to slave x. This makes the network less deterministic.

2.9 Baudrate switches

The ProfiSwitch X5 recognizes the transmission speed by default. The Main channel and Channels 1 to 5 can be locked to an individual transmission speed. The baudrate rotary switch of the Main channel will be detected automatically if the rotary switch is set to 0, B or C.

If the rotary switch of the individual channels is set to 0, that channel will work fully transparent in Hub mode. This is identical to a channel of a ProfiHub. For all other baudrates you can choose a different position of the rotary switch according to the table in the Technical Data chapter.

Using a baudrate on Channel 1 – 5 which is higher than the Main Channel is not recommended. The I/O of the slaves will not be faster than the original PLC/DCS program. Setting the speed higher can only increase the chance of errors.

To set the rotary switch, use a 3 mm screwdriver.

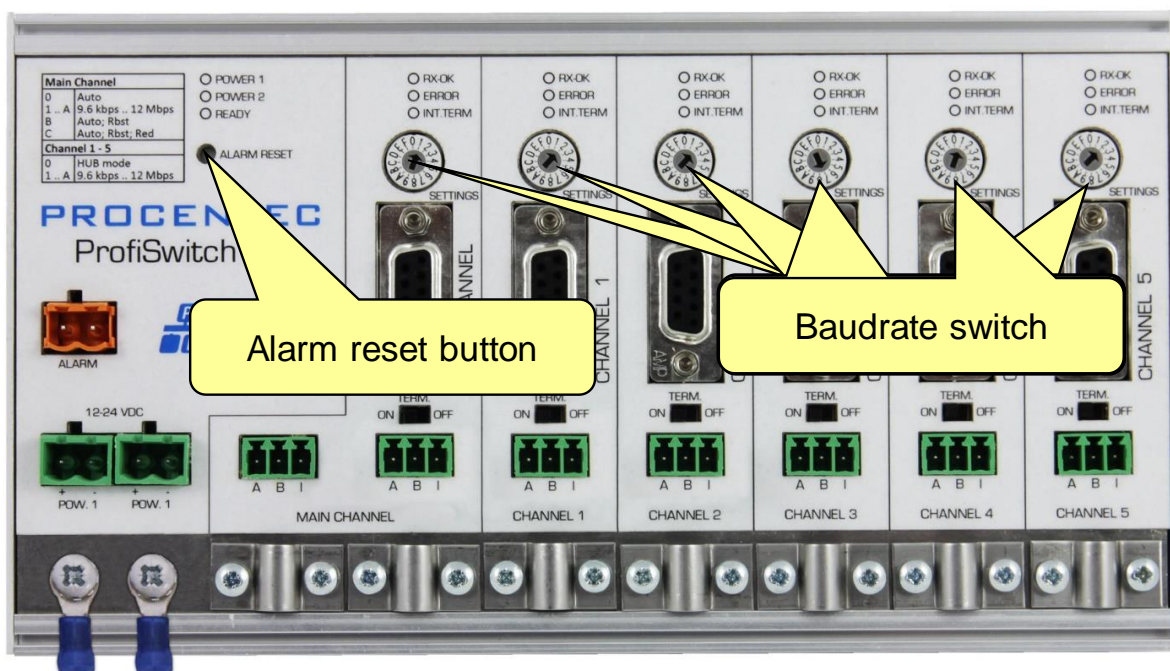

Fig. 16 – Baudrate speed switch

Please note that the position of the rotary switch of the main channel is only sampled during start-up. Changing the position of the switch will not have effect during operation. However, the rotary switches of channels 1-5 are sampled continuously. Changing the position will immediately change the baud rate.

The auto baudrate detect feature will search for the correct baud rate within 10 seconds of receiving the first telegram. This baud rate lock will be lost after 50 seconds of incorrect or no message reception.

2.10 Termination

The termination of the Channels have been set to ON by default, because it is assumed that the new segment is started at the ProfiHub (Fig. 15).

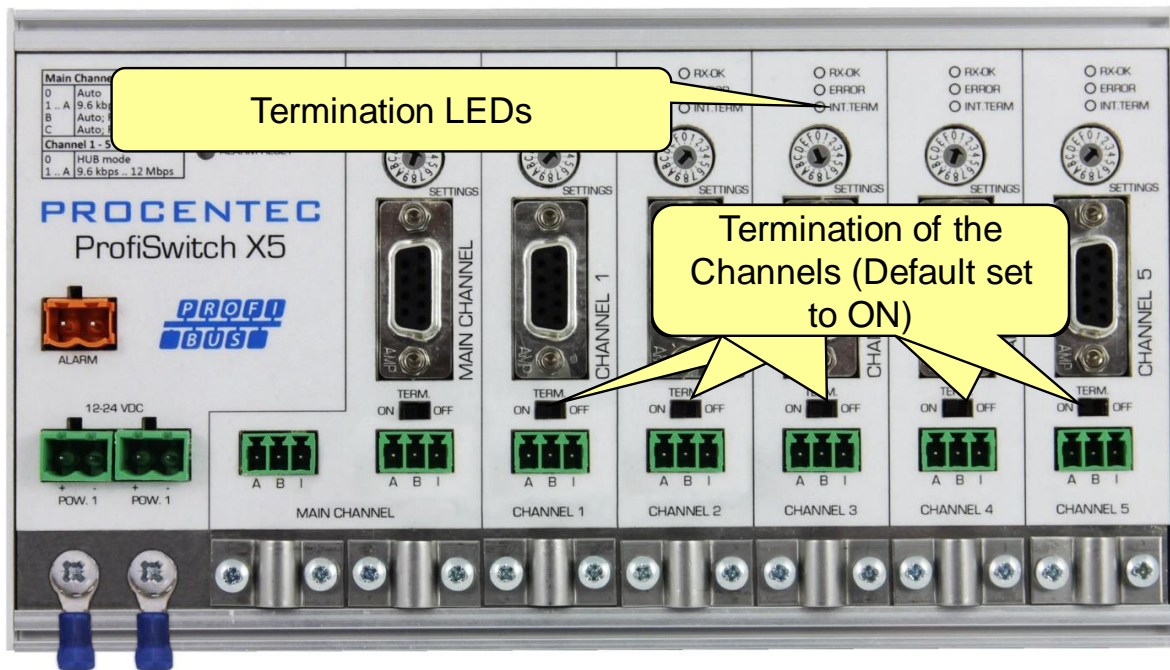

Fig. 15 – Termination switches

The termination LED of the corresponding Channel is activated when the termination switch is set to ON.

i When the DB9 connector is used and the cable starts at the ProfiHub, it is recommended to use the termination on the DB9 plug and NOT on the ProfiSwitch. This way the connector can be removed while maintaining termination on the bus.

2.11 Robust Repeating mode

The ProfiSwitch X5 has two repeating modes: normal (default) and Robust Repeating. In normal mode the bits are transferred directly on the other channel with a minimal delay (see delay times in the Technical Data chapter). In Robust mode (rotary setting B or C), the first byte is checked to verify if the following bits are a real PROFIBUS message. If the byte is illegal/corrupt, the message will not be transferred to the other channel. This helps network stability in EMC sensitive environments.

2.12 Channel Redundancy

To use the Redundancy option of the ProfiSwitch X5, set the rotary switch of the Main Channel to the 'C' position. This enables the two last channels (4 and 5) to be one redundant path to another ProfiSwitch X5, a B5+, to a redundant ComBricks, or to any other supporting product. See Fig. 17 for an example.

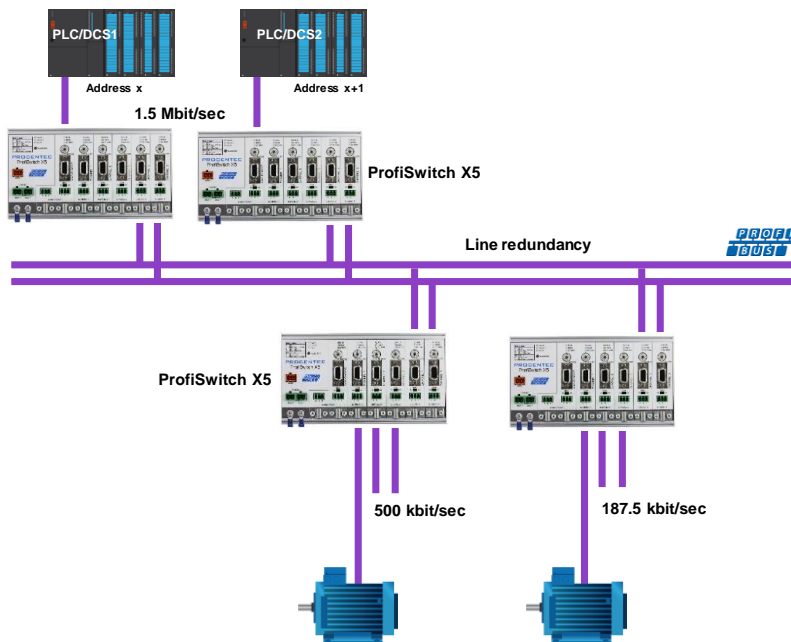

The telegrams are transferred onto both redundant channels. The logic inside the ProfiSwitch determines which telegram is used to be transferred onto the other channels. A message received by a redundant path is repeated on all other channels, except the other redundant channel. A message received by a normal channel is repeated on all other segments.

Figure 10 - Redundant path between multiple ProfiSwitches

When one redundant cable breaks, the other cable ensures safe delivery of the telegram. In this event the built-in alarm contact will close. The red 'ERROR' LED will blink with an interval of 100ms. When the redundant path is fixed, press the 'ALARM RESET' pushbutton to reset the alarm.

ATTENTION: for Redundancy to work properly, channel 4 and 5 are automatically set to 'Hub' mode. The rotary switch setting is bypassed. This means that channels 4 and 5 have the same baudrate as the main channel, and that they are completely transparent.

ATTENTION:

Using the ProfiSwitch X5 in Redundancy mode causes a delay in processing the telegrams. When used together with ComBricks in redundancy mode it is required to increase the default MinTSDR in the PLC bus parameters slightly. Recommended is to increase the MinTSDR with a value according to the delay time table in the Technical Data chapter.

3. Technical Data ProfiSwitch X5

Technical Data ProfiSwitch X5	
Dimensions and weight	
Dimensions L x W x H (mm) with screws	203 x 111 x 31
Weight	600 g
Ambient conditions	
Operating temperature	-25 to +70° Celsius -13 to +158° Fahrenheit
Isolation class	IP 20 (DIN 40 050)
Protocol specifications	
Supported Protocols	DP-V0, DP- V1, DP-V2, FDL, MPI, FMS, PROFIdrive and any other FDL based protocol. ProfiSafe is <u>not</u> supported.
Transmission speed	9.6 kbps to 12 Mbps
Transmission speed detection	Auto detect (default) or selectable with rotary switch
Transmission speed switch <u>main channel</u>	0 = Auto baudrate detect, Normal repeating (default) 1 = 9.6 kbps 2 = 19.2 kbps 3 = 45.45 kbps 4 = 93.75 kbps 5 = 187.5 kbps 6 = 500 kbps 7 = 1500 kbps 8 = 3000 kbps 9 = 6000 kbps A = 12000 kbps B = Auto baudrate detect, Robust repeating C = Auto baudrate detect, Robust repeating, redundancy on channel 4 and 5 D .. F = Same as 0
Transmission speed switch <u>channels 1-5</u>	0 = Hub mode (channel takes baudrate from main channel) 1 = 9.6 kbps 2 = 19.2 kbps 3 = 45.45 kbps 4 = 93.75 kbps 5 = 187.5 kbps 6 = 500 kbps 7 = 1500 kbps 8 = 3000 kbps 9 = 6000 kbps A = 12000 kbps B .. F = Not supported
Transmission speed detection time	< 10 s (if it is set to auto detect)

Technical Data ProfiSwitch X5			
Data delay time	At baudrate:	Normal mode:	Robust mode:
	9.6 - 93.75 kbps	≤1.7 Tbit	≤13.25 Tbit
	187.5 - 500 kbps	≤1.8 Tbit	≤13.30 Tbit
	1.5 Mbps	≤1.9 Tbit	≤13.40 Tbit
	3 Mbps	≤2.2 Tbit	≤13.60 Tbit
	6 Mbps	≤3.0 Tbit	≤14.00 Tbit
	12 Mbps	≤4.0 Tbit	≤15.00 Tbit
Delay time jitter	Max. ¼ bit time		
Cascading depth	No limits		
PROFIBUS cable specifications			
Cable lengths	1200 m at 9.6 kbps to 93.75 kbps 1000 m at 187.5 kbps 400 m at 500 kbps 200 m at 1.5 Mbps 100 m at 3 Mbps to 12 Mbps		
Cable thickness	10 mm (when the ground rail is used)		
Wire diameter	< 2.5 mm ²		
Wire type	Stranded or Solid core		
Number of devices	Maximum 31 per Channel (including ProfiHubs, OLMs etc)		
Termination	Integrated and switchable. Powered according to IEC 61158 (390/220/390 Ohms) - All Channels (default on)		
Redundancy	Optional (channel 4 and 5)		
Power supply specifications			
Power source	For UL: Limited Power Source (LPS) or NEC Class 2 or CEC Class 2, according to UL-60950-1 regulations		
Nominal supply voltage	12 to 24 VDC		
Redundant power supply	Yes		
Current consumption	Min 275 mA at 12 V power supply (all Channels fully loaded)		
Reverse polarity protection	Yes		
Cable thickness	10 mm (when the ground rail is used)		
Wire diameter	< 2.5 mm ²		
Alarm contact			
Voltage	Max. 24 V DC		
Current	0.5 A		
Others			
MTBF	T.b.d.		

4. Sales offices and distributors

HEADQUARTERS

PROCENTEC
Klopperman 16
2292 JD WATERINGEN
Netherlands

T: +31-(0)174-671800
F: +31-(0)174-671801
E: info@procentec.com
I: www.procentec.com

ARGENTINA

eFALCOM
Alcorta 2411
B1744 - Moreno
Buenos Aires
Argentina

T: +54 237 46 31 151
F: +54 237 46 31 150
E: santiago.falcomer@efalcom.com
I: www.efalcom.com.ar

AUSTRALIA

IS Systems Pty Limited
14 Laverick Ave.,
Tomago
NSW, Australia, 2322

T: +61 2 4964 8548
F: +61 2 4964 8877
E: fritz.woller@issystems.com.au
I: www.issystems.com.au

Pentair Flow Control Pacific
1 Percival Road
Smithfield
NSW, Australia, 2164

T: +61 2 4448 0466
F: +61 2 4423 3232
E: sharee.hazell@pentair.com.au
I: www.profibuscentre.com.au

BELGIUM and LUXEMBOURG

Bintz Technics N.V.
Brixtonlaan 23
B-1930 Zaventem
Belgium

T: +32 2 720 49 16
F: +32 2 720 37 50
E: bloemen@bintz.be
I: www.bintz.be

BRAZIL

Westcon Instrument. Indl Ltda
Rual Alvaro Rodrigues, 257
São Paulo – SP
Brazil - CEP 04582-000

T: +55 11 5561-7488
F: +55 11 5093-2592
E: paolo@wii.com.br
I: www.wii.com.br

CANADA

Streamline Process Management Inc.
#3, 4351 – 104 Ave SE
Calgary, Alberta T2C 5C6
Canada

T: +1 403 225 1986
F: +1 587 585 2828
E: admin@streamlinepm.com
I: www.streamlinepm.com

CHILE

RP Ingenieria Limitada
Tucapel 92 oficina 52
Concepción
Chile

T: +56-(0)41-2469350
F: +56-(0)41-2522592
E: rodrigopinto@rpingeneria.cl
I: www.rpingeneria.cl

CHINA

PROCENTEC Beijing
Room E-1115 WangJingYuan YouLeHui
ChaoYang
Beijing
China

T: +86(10)84766911 or 84787311
F: +86(10)84766722
E: info@procentec.net
I: www.procentec.net

CZECH REPUBLIC

FOXON s.r.o.
Polní 367
460 01 Liberec 12
Czech Republic

T: +420 484 845 555
F: +420 484 845 556
E: foxon@foxon.cz
I: www.foxon.cz

DENMARK

ProSaiCon
Jernbanegade 23B
DK 4000 Roskilde
Denmark

T: +45 70 20 52 01
F: +45 70 20 52 02
E: hfj@prosaicon.dk
I: www.prosaicon.dk

EGYPT

Mas Trading
37, 105 Street
Al-Etihad Square
Egypt

T: +2 02 2524 2842
F: +2 02 2524 2843
E: aya.elshafei@masautomation.com
I: www.masautomation.com

ESTONIA

Saksa Automaatika OU
Peterburi Tee 49
Tallinn
EE-11415 Estonia

T: +372 605 2526
F: +372 605 2524
E: info@saksa-automaatika.ee
I: www.saksa-automaatika.ee

FINLAND

Hantekno Oy
Kalliotie 2
04360 Tuusula
Finland

T: +358 40 8222 014
E: info@hantekno.com
I: www.hantekno.fi

FRANCE

AGILiCOM
Bâtiment B
1, rue de la Briaudière
Z.A. La Châtaigneraie
37510 BALLAN-MIRE
France

T: +33 247 76 10 20
F: +33 247 37 95 54
E: jy.bois@agilicom.fr
I: www.agilicom.fr

GERMANY

PROCENTEC GmbH
Benzstrasse 15
D-76185 Karlsruhe
Germany

T: +49-(0)721 831 663-0
F: +49-(0)721 831 663-29
E: info@procentec.de
I: www.procentec.de

INDIA

UL Engineering Services & Software Pvt Ltd
Nirman Classic,
Katraj-Kondhwa Road,
Katraj, Pune-411046
India

T: +91-202 696 0050
F: +91-202 696 2079
E: dileep.miskin@ulepl.com
I: www.ulepl.com

IRELAND

PROFIBUS Ireland
Automation Research Centre
University of Limerick
National Technology Park, Plassey
Limerick
Ireland

T: +353-61-202107 or +35361240240
F: +353-61-202582
E: info@profibus.ie
I: www.profibus.ie

ISRAEL

Instrumentics Industrial Control
8 Hamlacha St.
New Industrial Zone
Netanya, 42170
Israel

T: +972-9-8357090
F: +972-9-8350619
E: info@instrumentics-ic.co.il
I: www.inst-ic.co.il

ITALY

PROCENTEC Italy
Via Branze n. 43/45
25123 Brescia
Italy

T: +39 030 200 8610
F: +39 030 238 0059
E: www.procentec.it
W: www.procentec.it

JAPAN

TJ Group
C/O Japanese PROFIBUS Organisation
West World Building 4F
3-1-6 Higashi-Gotanda,
Shinagawa-ku,
Tokyo, 141-0022
Japan

T: +81-3-6450-3739
F: +81-3-6450-3739
E: info@profibus.jp

KOREA

Hi-PRO Tech. Co., Ltd.
#2802, U-Tower, 1029
Youngduk-dong, Giheung-gu
Yongin-Si, Kyunggi-do,
446-908 Korea

T: +82 82-31-216-2640
F: +82 82-31-216-2644
E: chays@hiprotech.co.kr
I: www.profibus.co.kr

LEBANON

Industrial Technologies S.A.L. (ITEC)
Point Center, Boulevard Fouad Chehab
Sin El Fil
Beirut
Lebanon

T: +961 1 491161
F: +961 1 491162
E: sales@iteclb.com
I: www.iteclb.com

MEXICO

Grid Connect Inc.

T: +1 530-219-2565 (Spanish)
E: tomf@gridconnect.com
I: www.gridconnect.com

NETHERLANDS

PROCENTEC B.V.
Klopperman 16
2292 JD Wateringen
Netherlands

T: +31 (0)174 671800
F: +31 (0)174 671 801
E: info@procentec.com
I: www.procentec.com

NORWAY

Nortelco Automation AS
Johan Scharffenbergs vei 25
N-0694 Oslo
Norway

T: +47 22 57 61 00
E: post@nortelcoautomation.no
I: www.nortelcoautomation.no

PERU

ControlWare
Jr. Los Silicios 5409
Los Olivos - L39
Peru

T: +51 1637 3735
F: +51 1528 0454
E: info@controlware.com.pe
I: www.controlware.com.pe

POLAND

INTEX Sp. z o.o.
ul. Portowa 4
44-102 Gliwice
Poland

T: +48 32 230 75 16
F: +48 32 230 75 17
E: intex@intex.com.pl
I: www.intex.com.pl

ROMANIA

S.C. SVT Electronics S.R.L.
Brăila 7
540331 Tg-Mure
Romania

T: +40 365 809 305
F: +40 365 809 305
E: sajgo.tibor@svt.ro
I: www.svt.ro

SAUDI ARABIA

ASM Process Automation
Al-Zahra Dist. – Attas st.
cross section with helmy Kutby St.
Villa no.25
Jeddah-21553
Saudi Arabia

T: +966 2 691 2741
F: +966 2 682 8943
E: info@asmestablishment.com
I: www.asmeestablishment.com

SINGAPORE / SOUTH EAST ASIA

Allegro Electronics
236 Serangoon Avenue 3 07-98
Singapore 550236

T: +65 62878063
E: sales@allegro.com.sg
I: www.allegro.com.sg

Gissmatic Automatisierung Pte Ltd
318 Tanglin Road 01-34
Singapore 247979

T: +65 900 912 76
E: sales@gissmatic.com
I: www.gissmatic.com

SLOVAKIA

ControlSystem s.r.o.
Stúrova 4
977 01 BREZNO
Slovakia

T: +421 486115900
F: +421 486111891
E: jan.snopko@controlsystem.sk
E: jan.snopko@controlsystem.sk

SOUTH AFRICA

IDX ONLINE CC
1 Weaver Street
Fourways
Johannesburg
South Africa - 2191

T: +27(11) 548 9960
F: +27(11) 465-8890
E: sales@idxonline.com
I: www.idxonline.com

SPAIN

LOGITEK, S.A
Ctra. de Sant Cugat, 63 Esc. B Planta 1ª
Rubí (BARCELONA), 08191
Spain

T: +34 93 588 6767
E: xavier.cardena@logitek.es
I: www.logitek.es

SWEDEN

P&L Nordic AB
Box 252
S-281 23 Hässleholm
Sweden

T: +46 451 74 44 00
F: +46 451 89 833
E: hans.maunsbach@pol.se
I: www.pol.se/profibus

SWITZERLAND

**Berner Fachhochschule
PROFIBUS Kompetenzzentrum**
Jlcoweg 1
CH-3400 Burgdorf
Switzerland

T: +41 (0) 34 426 68 32
F: +41 (0) 34 426 68 13
E: max.felser@bfh.ch
I: www.profitrace.ch

TAIWAN

Full Data Technology
6F., No.200, Gangqian Rd.
Neihu District, Taipei City
114, Taiwan

T: +886-2-87519941/9097
F: +886-2-87519533
E: sales@fulldata.com.tw
I: www.fulldata.com.tw

TURKEY

Emikon Otomasyon
DES Sanayi sitesi 103 sokak
B-7 blok No:16 Yukari Dudullu / Umraniye
Istanbul 34776
Turkey

T: +90 216 420 8347
F: +90 216 420 8348
E: tolgaturunz@emikonotomasyon.com
I: www.emikonotomasyon.com

UNITED ARAB EMIRATES

Synergy Controls
907, IT Plaza Silicon Oasis :
Dubail
United Arab Emirates

T: +971 4 3262692
F: +971 4 3262693
E: sales@synergycontrols.ae

UNITED KINGDOM and N. Ireland

Verwer Training & Consultancy
5 Barclay Road
Poynton, Stockport
Cheshire SK12 1YY
United Kingdom

T: +44 (0)1625 871199
E: andy@verwertraining.com
I: www.verwertraining.com

Hi-Port Software
The Hub 2 Martin Close
Lee-on-Solent
Hampshire PO13 8LG
United Kingdom

T: +44 (0)8452 90 20 30
F: +44 (0)2392 552880
E: sales@hiport.co.uk
I: www.hiport.co.uk

iTech
Unit 1
Dukes Road
Troon
Ayrshire KA10 6QR
United Kingdom

T: +44 (0)1292 311 613
F: +44 (0)1292 311 578
E: sales@itech-troon.co.uk
I: www.itech-troon.co.uk

Parkelect Ltd.
84 Dargan Road
Belfast
BT3 9JU
N. Ireland

T: +44 2890 777743
F: +44 2890 777794
E: jgillan@parkelect.co.uk
I: www.parkelect.co.uk

UNITED STATES

Grid Connect Inc.
1630 W. Diehl Road
Naperville, Illinois 60563
USA

T: +1 630 245-1445
F: +1 630 245-1717
E: sales@gridconnect.com
I: www.gridconnect.com/procentec.html

VIETNAM

Bavitech Corporation
42 Truong Son Street
Ward 2, Tan Binh District
Ho Chi Minh City
Vietnam

T: +84-8-3547 0976
F: +84-8-3547 0977
E: hai.hoang@bavitech.com
I: www.bavitech.com

For the up to date list of the Sales Offices and Distributors see www.procentec.com/company/distributors/. If your country or region is not listed, please contact us. We are still searching for distributors who can cover complete areas or countries.



5. Order codes

Component	Order code	Remarks
 ProfiSwitch X5	17030X	ProfiSwitch X5

6. Glossary

Address	Unique number of a device connected to the network. With PROFIBUS this can be 0 to 126. 127 is a broadcast address.
Analyzer	Software tool to observe the protocol traffic. Combi-Analyzers can also inspect the signal quality. Other term: Bus Monitor. Example: ProfiTrace.
Backbone	The primary bus cable. Most of the time only the control systems, ProfiHubs and fiber optic couplers are connected to this cable. The field devices are connected behind the ProfiSwitches, ProfiHubs and fiber optic couplers.
Bit Time (Tbit)	The bit time Tbit is the time, which elapses during the transmission of one bit. It depends on the baudrate and is calculated as follows $Tbit = 1 \text{ (bit)} / \text{baudrate (bps)}$. Examples: 12 Mbps --> Tbit = 83 ns 1.5 Mbps --> Tbit = 667 ns
Busparameters	Settings that define the timing behaviour on the bus. They are defined in the master. Examples: Tslot, MaxTSDR.
C	Capacitance.
DGND	Digital Ground.
DIN	German Institute for Standardization (www.din.de).
DP-V0	DP-V0 is the basic stage of the PROFIBUS DP communication protocol. DP-V0 devices (master and slaves) perform the following basic functionalities: <ul style="list-style-type: none">- Cyclic exchange of I/O data between controlling and slave devices- Device, Identifier (module) and Channel related Diagnosis- Parameterization of DP-slaves- Configuration of DP-slaves
DP-V1	DP-V1 is the first stage of extension of PROFIBUS DP after DP-V0. DP-V1 devices shall comply with the following features: <ul style="list-style-type: none">- Device related diagnosis is replaced by status and alarms.- The first three octets of the user parameterization data are now standardized- Optionally these devices may support:- Acyclic communication (MS1, MS2)- If alarms are used, MS1 shall be supported

DP-V2	<p>DP-V2 is the second stage of extension of PROFIBUS DP after DP-V1. DP-V2 devices shall comply with the following features:</p> <ul style="list-style-type: none"> - Data Exchange Broadcast (DxB) for slave to slave communication (publisher/subscriber principle). - Isochronous Mode (time tick synchronized operating slaves, e.g. drives) - Up- and/or download of Load Region Data (domains) - Clock Control (synchronization within slaves) and Time Stamping - Redundancy.
Electromagnetic Compatibility	See EMC.
EMC	<p>The extent to which an electric or electronic device will tolerate electrical interference from other equipment (immunity), and will interfere with other equipment. Within the European Community as well as in other countries it is regulated by law that electric and electronic components and equipment comply with basic standards such as IEC 61000-6-2 or IEC 61326 or corresponding individual product standards.</p>
Hub	<p>A Hub refreshes a signal and passes the information on to all nodes which are connected to the Hub. Data frames which were received on one port are transferred to all the other ports (chicken foot topology).</p>
MPI	<p>Multiple Protocol Interface. Protocol defined by Siemens which uses the layer 1 and 2 of PROFIBUS (FDL).</p>
PCB	Printed Circuit Board.
PROFIBUS DP	<p>Acronym for "PROFIBUS for Decentralized Peripherals". Specification of an open fieldbus system with the following characteristics:</p> <ul style="list-style-type: none"> - Polling master-slave-system (cyclic communications, MS0) - Flying masters with robin round token passing coordination (MM) - Connection based (MS1) and connectionless (MS2, MS3) acyclic communication between masters and slaves <p>Options (e.g.):</p> <ul style="list-style-type: none"> - Data exchange broadcast (DXB), i.e. slave to slaves communication - Isochronous mode of slaves - Clock synchronization - Redundancy <p>PROFIBUS DP is standardized within IEC 61158 and IEC 61784, communication profile families 3/1 and 3/2</p> <p>The term "PROFIBUS DP" also is a synonym for the RS485 based deployments within factory automation.</p>
Repeater	<p>Active physical layer device that receives and retransmits all signals over a different port to increase the distance and number of devices for which signals can be correctly transferred for a given medium.</p>
Spur line	<p>A cable attached to a bus segment with a T-connection . Spurs are not recommended with PROFIBUS DP. They are prohibited with 12 Mbps and PROFIsafe operations. German term is "Stichleitung".</p>
Stub line	See <i>Spur line</i> .

Tbit	See <i>Bit Time</i> .
Termination	A (powered) resistor network at both ends of a segment to prevent reflections (with PROFIBUS DP the termination must be powered).
Topology	In a communications network, the pattern of interconnection between network nodes; e.g. bus, ring, star configuration.
PI	PROFIBUS International. The International PROFIBUS Organization based in Karlsruhe.
\	PROFIBUS Nutzer Organization. The German PROFIBUS Organization based in Karlsruhe.
Drop cable	See <i>Spur line</i> .
Reflection	Part of the original signal that is transmitted back along the cable. It corrupts the original signal.



7. About PROCENTEC

PROCENTEC is a specialist in PROFIBUS and PROFINET technology and develops products to optimize the production processes of end users. Our innovative solutions ensure that our customers successfully operate in the world of industrial automation and enjoy maximum results from their processes.

PROCENTEC globally supplies all the components required to install a measurable and controllable network. Our products measure, signal and connect the various elements of a process installation and ensure it runs optimally. We develop and produce all products in the Netherlands and export them through our worldwide distribution network. PROCENTEC also is the international accredited Competence and Training center for PROFIBUS and PROFINET. We provide training courses that help employees using those techniques optimally for their business objectives. In addition we also provide the necessary support to end users during their implementation procedures, certification processes, audits and malfunctions.

We are of the opinion that the industrial markets need the confidence of believing in the reliable PROFIBUS / PROFINET technology and applications, to ensure their processes are not threatened in any way and the continuity remains guaranteed. In view of the possible negative consequences and impact in that industry, we therefore think that those companies have the right to the best solutions and honest expert advice. Based on that belief, PROCENTEC continues to innovate and develop, which makes us the most reliable service provider and knowledge partner for our customers. We do all of this with total dedication.

We believe that it is important to communicate with our customers, partners, distributors and suppliers in a transparent and decent way. We are empathic, truly interested and passionate in everything we do. Quality, continuity, service and sustainability are essential to us. That enables us to provide our customers with groundbreaking and tailor-made solutions.

Products

- ProfiTrace
- ComBricks
- ProfiHub
- PROFINET tools
- Cables and connectors

Training courses

- PROFIBUS training courses
- PROFINET training courses
- Product training courses

Services

- Competence center
- Support & Consultancy
- Network certification & Audits
- Testlab & Democenter



8. Certificates

certificate

QualityMasters hereby declares that

Procentec B.V.
Wateringen

has a management system that meets the requirements of the standard

NEN-EN-ISO 9001:2015

for the scope

Providing training courses, technical support, product development and the exploitation of the test laboratory.

Date of original approval	10-02-2003
Date of issue	27-01-2017
Valid until	10-02-2019
Certificate number	NL 6594-uk-a

On behalf of Stichting QualityMasters,



N.B. The failure to meet the conditions as set forth in the certification agreement, or non-compliance with the given standard and/or guidelines, may lead to the suspension or cancellation of the certificate.
This certificate remains the property of Stichting QualityMasters, Nieuwland Parc 157, 3351 LJ Papendrecht.



**Certificate
for a PI Competence Center**

PI confirms that

**PROCENTEC
Elmer Vis
Klopperman 16
2292 JD WATERINGEN
NETHERLANDS**

is a fully accredited PI Competence Center for
PROFIBUS basic
PROFIBUS Process Automation
PROFIsafe.

This certificate is granted according to the Quality of Services Agreement for
PI Competence Centers and is valid until December 31, 2017.



(Official in Charge)

Chairmen of PI



(Karsten Schneider, Chairman)



(Michael J. Bryant, Deputy Chairman)



Certificate

Authorization as PI Test Laboratory for PROFIBUS

PROFIBUS Nutzerorganisation e.V. accepts
PROCENEC
Klopperman 16
2292 JD Wateringen
The Netherlands

as authorized PI Test Laboratory for:

PROFIBUS Slave Devices PA Profile Devices

The authorization is based on the assessment dated February 19, 2015, and the related assessment report.

The execution of the tests aimed in the PROFIBUS certification shall be conform to the PROFIBUS Standard and the valid guidelines.

This authorization is valid until December 31, 2016.



(Official in Charge)

Board of PROFIBUS Nutzerorganisation e. V.

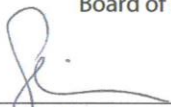

(K. Schneider)

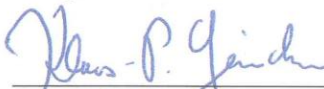

(K.-P. Lindner)



PROFI[®]
BUS

9. Revision history

Version 1.0.0

- Initial release



PROCENTEC BV
Klopperman 16
2292 JD Wateringen
The Netherlands

T: +31 (0)174 671 800

F: +31 (0)174 671 801

E: support@procentec.com

W: www.procentec.com

