

## Features

- Surface Mount / Single Turn / Cermet Industrial / Sealed
- Compatible with surface mount manufacturing processes
- Compatible with popular vacuum pick-and-place equipment
- J-hook, gull-wing and pinned configurations
- Side adjust available
- Meets EIA/EIAJ/IPC/VECI SMD standard trimmer designs
- RoHS compliant\* - see [processing information](#) on lead free surface mount trimmers
- For trimmer applications/processing guidelines, [click here](#)

# 3314 - 4 mm Square Timpot® Trimming Potentiometer

### Electrical Characteristics

Standard Resistance Range ..... 10 ohms to 2 megohms (see standard resistance table)  
 Resistance Tolerance ..... ±20 % std. (tighter tolerance available)  
 End Resistance ..... 1 % or 2 ohms max. (whichever is greater)  
 Contact Resistance Variation ..... 3 % or 3 ohms  
 Resolution ..... Infinite  
 Insulation Resistance ..... 500 vdc. 100 megohms min.  
 Dielectric Strength  
 Sea Level..... 500 vac (1 minute)  
 Adjustment Angle ..... 210 ° nom.

### Environmental Characteristics

Power Rating (300 volts max. for Style G, J & H; 50 volts max. for Style R)  
 70 °C ..... 0.25 watt  
 125 °C ..... 0 watt  
 Temperature Range ... -55 °C to +125 °C  
 Temperature Coefficient ... ±100 ppm/°C  
 Seal Test .. 85 °C Fluorinert<sup>†</sup>/60 seconds  
 Humidity ..... 90-98 % RH, 10 cycles, 240 hours  
 TRS ±2 %; IR 10 megohms  
 Vibration ..... 20 G TRS ±1 %; VRS ±1 %  
 Shock ..... 100 G TRS ±1 %; VRS ±1 %  
 Load Life  
 .... (@ 70 °C Rated Power 1000 Hours)  
 TRS ±3 %  
 Rotational Life ..... 100 cycles  
 TRS ±3 %  
 Thermal Shock ..... 5 cycles  
 TRS ±2 %; VRS ±1 %

### Physical Characteristics

Mechanical Angle ..... 240 ° nom.  
 Torque..... 180 g-cm max.  
 Stop Strength ..... 300 g-cm min.  
 Pushover Strength (S & Z Style)  
 ..... 1.6 kilograms (3.5 lbs.) min.  
 Weight ..... Approximately 0.01 oz.  
 Marking..... Manufacturer's code, resistance code and date code  
 Wiper ..... 50 % (Actual TR) ±10 %  
 Flammability ..... U.L. 94V-0  
 Standard Packaging  
 J, G and R... 500 pcs./7 " reel (MSL-1)  
 S and Z..... 200 pcs./7 " reel (MSL-1)  
 H..... 100 pcs./tube  
 Adjustment Tool..... H-90

### Product Dimensions

3314J-1

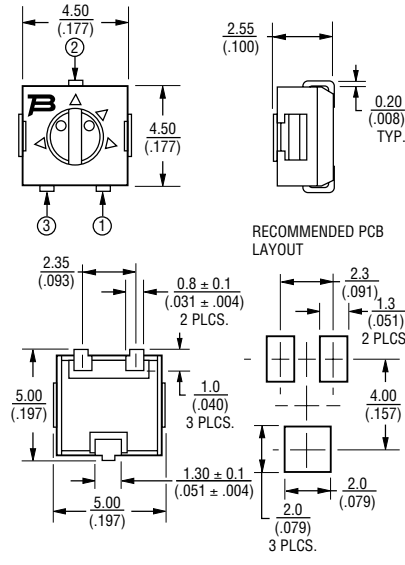

3314G-1

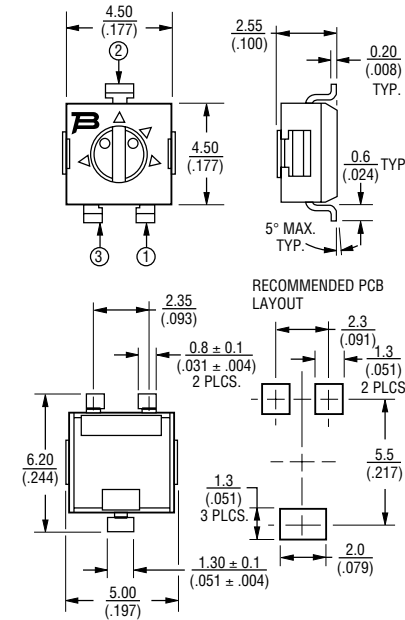

3314H-1

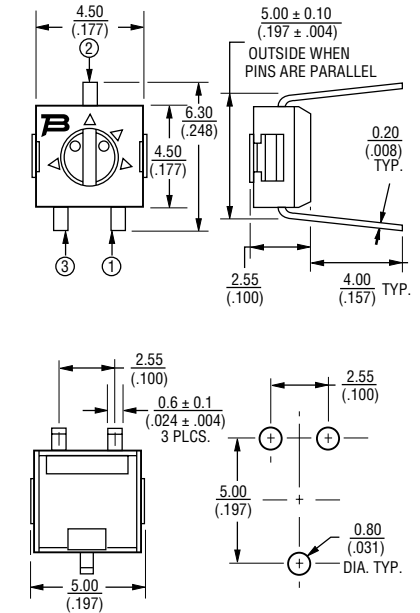

3314J-1, G-1, R-1, H-1 (Bourns Marking, Straight Slot)

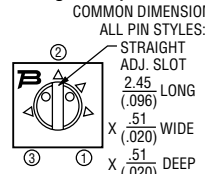

3314J-2, G-2, R-2, H-2 (Bourns Marking, Cross Slot)

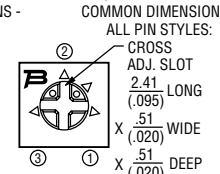

3314J-3, G-3, R-3, H-3 (Reverse Marking, Straight Slot)

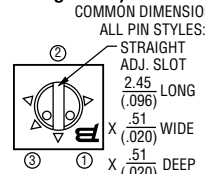

3314J-4, G-4, R-4, H-4 (Reverse Marking, Cross Slot)

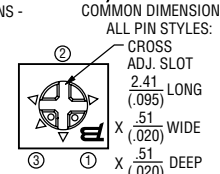

DIMENSIONS:  $\frac{\text{MM}}{\text{(INCHES)}}$   
 TOLERANCES: ±  $\frac{0.25}{(.010)}$  EXCEPT WHERE NOTED

\*RoHS Directive 2002/95/EC Jan. 27, 2003 including annex and RoHS Recast 2011/65/EU June 8, 2011.

<sup>†</sup>Fluorinert<sup>™</sup> is a registered trademark of 3M Co.

Specifications are subject to change without notice.

The device characteristics and parameters in this data sheet can and do vary in different applications and actual device performance may vary over time. Users should verify actual device performance in their specific applications.

# 3314 - 4 mm Square Trimpot® Trimming Potentiometer

**BOURNS®**

## Product Dimensions

### 3314R-1

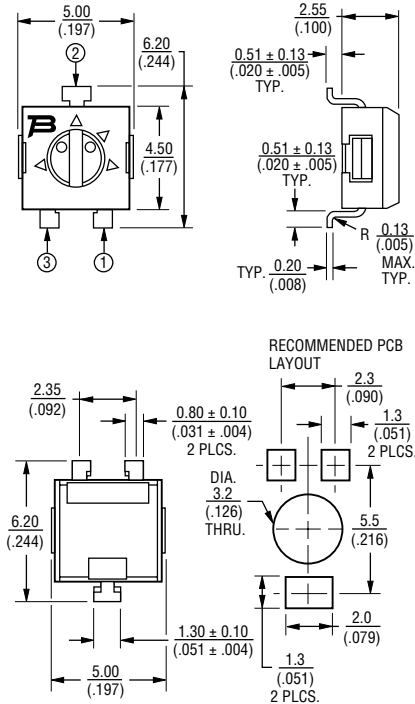

### 3314R-GM5

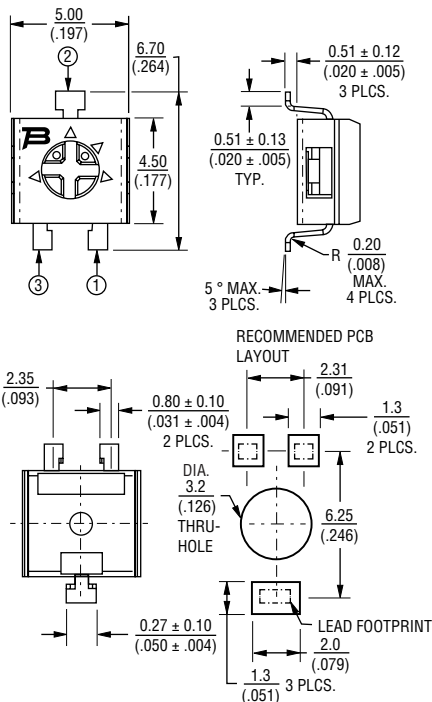

### 3314S-1 (Bourns Marking, Straight Slot)

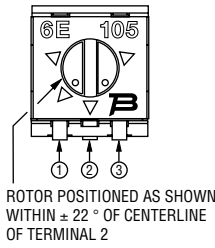

### 3314S-2 (Bourns Marking, Cross Slot)

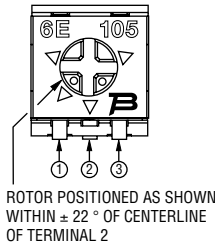

### 3314S-3 (Reverse Marking, Straight Slot)

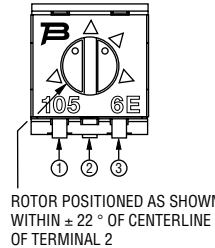

### 3314S-4 (Reverse Marking, Cross Slot)

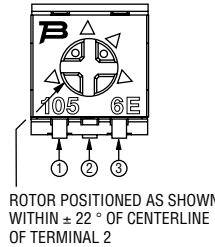

### 3314S Common Dimensions

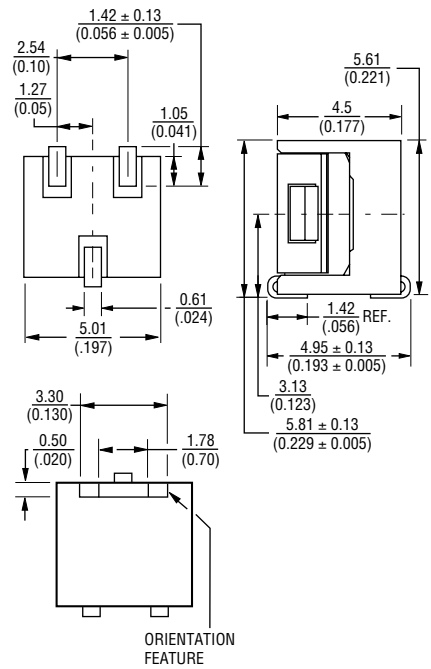

### RECOMMENDED PCB LAYOUT

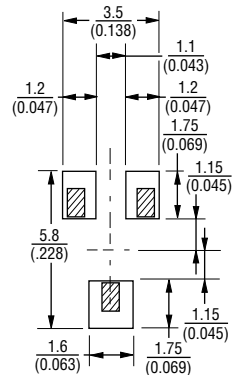

DIMENSIONS:  $\frac{\text{MM}}{\text{(INCHES)}}$   
 TOLERANCES: ±  $\frac{0.25}{(.010)}$  EXCEPT WHERE NOTED

Specifications are subject to change without notice. The device characteristics and parameters in this data sheet can and do vary in different applications and actual device performance may vary over time. Users should verify actual device performance in their specific applications.

# 3314 - 4 mm Square Trimpot® Trimming Potentiometer

# BOURNS®

## Product Dimensions

**3314Z-1-(RC) E**  
(Cross Slot)



ROTOR POSITIONED AS SHOWN WITHIN ± 22° OF CENTERLINE OF TERMINAL 2

**3314Z-GA4-(RC) E**  
(Straight Slot)



ROTOR POSITIONED AS SHOWN WITHIN ± 22° OF CENTERLINE OF TERMINAL 2

**3314Z-3**  
(Reverse Marking, Straight Slot)



ROTOR POSITIONED AS SHOWN WITHIN ± 22° OF CENTERLINE OF TERMINAL 2

**3314Z-4-(RC) E**  
(Reverse Marking, Cross Slot)



ROTOR POSITIONED AS SHOWN WITHIN ± 22° OF CENTERLINE OF TERMINAL 2

**3314Z**  
Common Dimensions

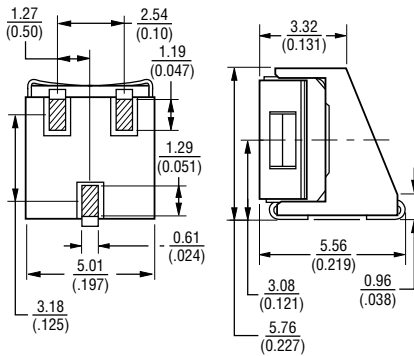

RECOMMENDED PCB LAYOUT

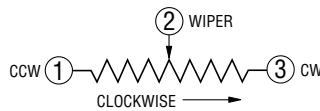
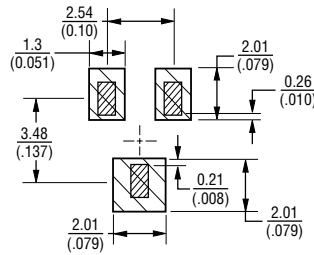

## Packaging Specifications

(J, G Styles)

TAPE

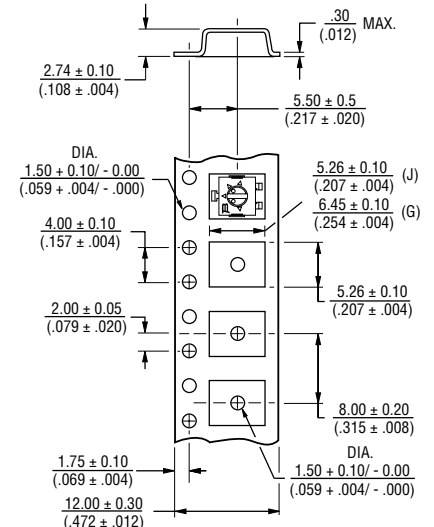

REEL

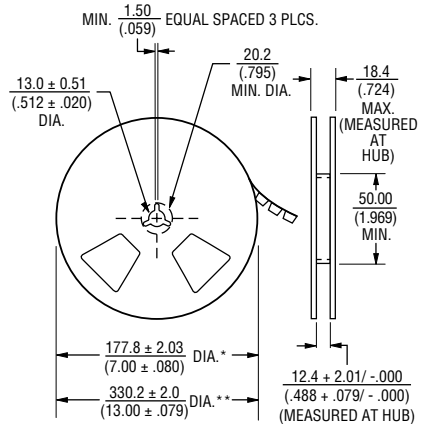

\* Embossed Tape Designator "E"

\*\* Embossed Tape Designator "G"

(See How To Order chart for further information.)

Meets EIA specification 481.

DIMENSIONS:  $\frac{\text{MM}}{\text{(INCHES)}}$   
TOLERANCES: ±  $\frac{0.25}{(.010)}$  EXCEPT WHERE NOTED

Specifications are subject to change without notice. The device characteristics and parameters in this data sheet can and do vary in different applications and actual device performance may vary over time. Users should verify actual device performance in their specific applications.

# 3314 - 4 mm Square Trimpot® Trimming Potentiometer

# BOURNS®

## Packaging Specifications

### (R Style)

TAPE

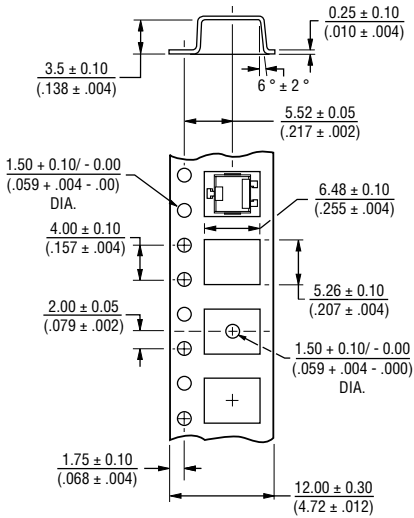

REEL

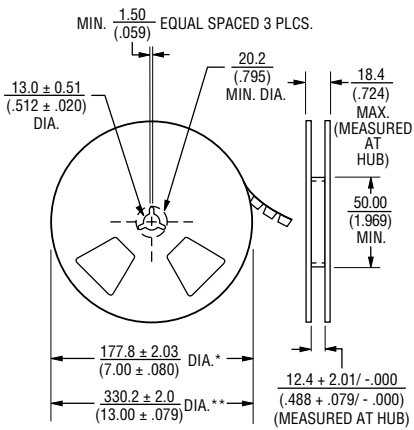

\* Embossed Tape Designator "E"  
 \*\* Embossed Tape Designator "G"  
 (See How To Order chart for further information.)

Meets EIA specification 481.

DIMENSIONS:  $\frac{\text{MM}}{\text{(INCHES)}}$

TOLERANCES:  $\pm \frac{0.25}{(.010)}$  EXCEPT WHERE NOTED

### (R-GM5 Style)

TAPE

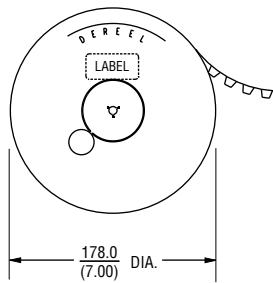
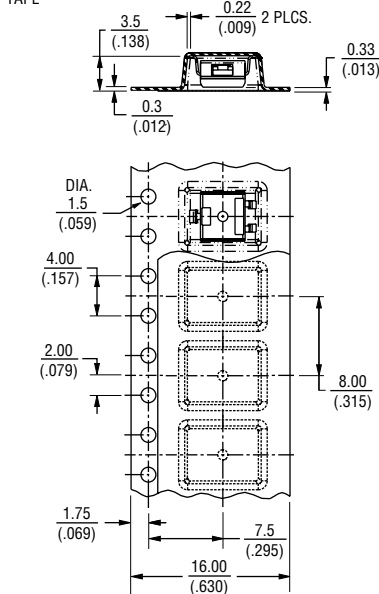

### (S Style)

TAPE

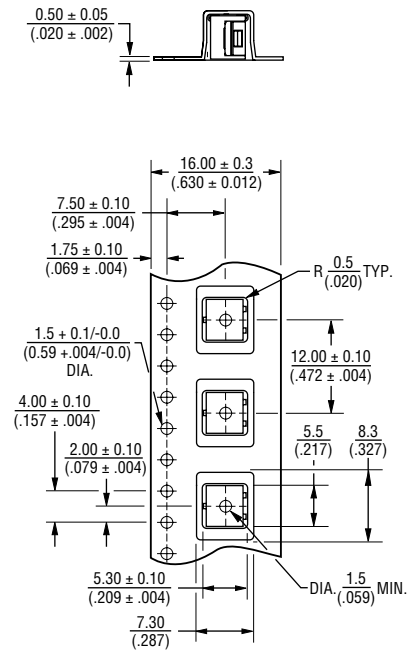

REEL

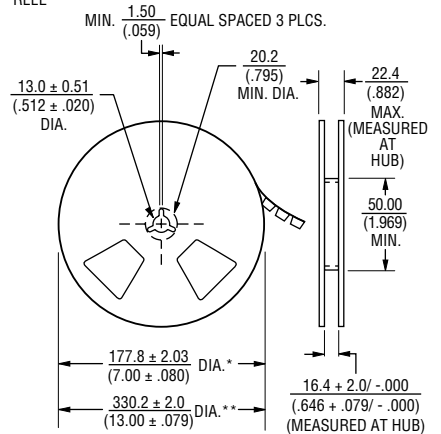

\* Embossed Tape Designator "E"  
 \*\* Embossed Tape Designator "G"  
 (See How To Order chart for further information.)

Meets EIA specification 481.

Specifications are subject to change without notice.  
 The device characteristics and parameters in this data sheet can and do vary in different applications and actual device performance may vary over time.  
 Users should verify actual device performance in their specific applications.

# 3314 - 4 mm Square Trimpot® Trimming Potentiometer

# BOURNS®

## Packaging Specifications

(Z Style)

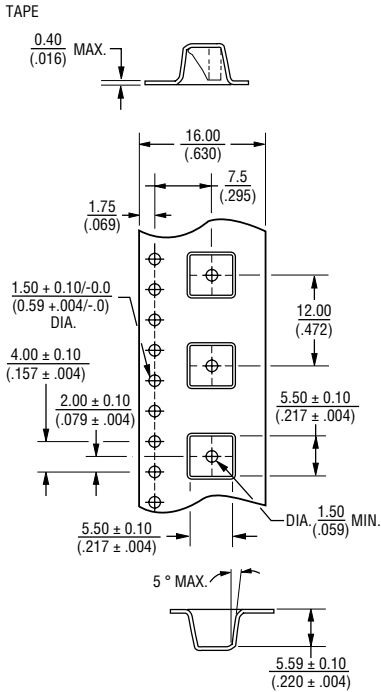

REEL

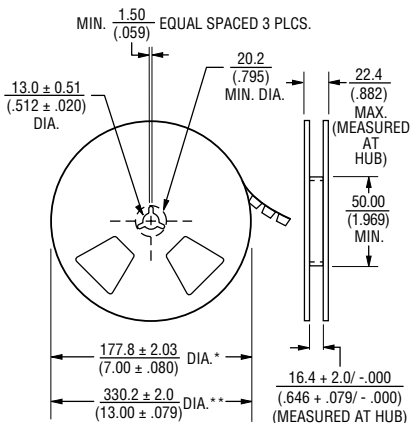

\* Embossed Tape Designator "E"  
 \*\* Embossed Tape Designator "G"  
 (See How To Order chart for further information.)

Meets EIA specification 481.

## How To Order

**3314 J - 1 - 502 E**

Model \_\_\_\_\_  
 Style \_\_\_\_\_  
 Standard or Modified Product Indicator (Styles J, G, H & S) \_\_\_\_\_  
 -1 = Single Slot  
 -2 = Cross Slot  
 -3 = Single Slot w/Reverse Marking  
 -4 = Cross Slot w/Reverse Marking  
 Product Indicator (Style R only)  
 -GM5 = Cross Slot w/Extended Lead Frame  
 -1 = Single Slot  
 -2 = Cross Slot  
 -3 = Single Slot w/Reverse Marking  
 -4 = Cross Slot w/Reverse Marking  
 Product Indicator (Style Z only)  
 -GA4 = Single Slot  
 -1 = Cross Slot  
 -3 = Single Slot w/Reverse Marking  
 -4 = Cross Slot w/Reverse Marking  
 Resistance Code \_\_\_\_\_  
 Embossed Tape Designator (MSL-1)\*\*  
 E = Styles J, G and R: 500 pcs./7 " reel  
 Styles S and Z: 200 pcs./7 " reel  
 G = Styles J and G: 3000 pcs./13 " reel  
 Style R: 2500 pcs./13 " reel  
 Styles S and Z: 1000 pcs./13 " reel  
 \*\*Style H is available in tube packaging only.

Tape and reel material meets Antistatic ANSI/ESD 5541-2003 packaging standards.

## Standard Resistance Table

Resistance (Ohms)	Resistance Code
10	100
20	200
50	500
<b>100</b>	<b>101</b>
<b>200</b>	<b>201</b>
<b>500</b>	<b>501</b>
<b>1,000</b>	<b>102</b>
<b>2,000</b>	<b>202</b>
<b>5,000</b>	<b>502</b>
<b>10,000</b>	<b>103</b>
<b>20,000</b>	<b>203</b>
<b>50,000</b>	<b>503</b>
<b>100,000</b>	<b>104</b>
200,000	204
250,000	254
500,000	504
1,000,000	105
2,000,000	205

Popular distribution values listed in boldface.  
 Special resistances available.

DIMENSIONS:  $\frac{\text{MM}}{\text{(INCHES)}}$

TOLERANCES:  $\pm \frac{0.25}{(.010)}$  EXCEPT WHERE NOTED

REV. 05/16

Specifications are subject to change without notice.  
 The device characteristics and parameters in this data sheet can and do vary in different applications and actual device performance may vary over time.  
 Users should verify actual device performance in their specific applications.