



®

Operating Instructions

Multi Function Tester

Item no: 2997218 (IST 3000)

Item no: 2997219 (IST 3000E + Active test lead)

Item no: 2997220 (IST 1000)

CE



Table of Contents

Introduction.....	5
Operating Instructions for download.....	5
Intended use.....	5
Delivery contents.....	6
1. Safety and operational considerations	7
2.1 Warnings and notes.....	7
2.2 Batteries	9
2.3 Charging [Internal recharging Voltcraft IST 3000 only].....	10
2.4 Precautions on charging of new battery cells or cells unused for a longer period.....	10
2.5. Standards applied.....	11
2.6. Model Specifications	11
2. Instrument description	13
2.1. Front panel (depends on model).....	13
2.2. Connector panel (depends on model).....	14
2.3. Back panel	14
2.4. Bottom view – Information label	16
2.5. Carrying the instrument	16
4. Instrument operation	17
4.1. Meaning of symbols and messages on the Instrument display	17
4.2. The online voltage and output terminal monitor	18
4.3. Message field – battery status	18
4.4. Status field – measurement warnings/results symbols	19
4.5. Sound warnings	19
4.6. Performing measurement	20
4.6.1. Measurement function/sub-function	20
4.6.2. Selecting measurement function/sub-function.....	20
4.6.3. Performing tests	20
4.7. Setup menu	20
4.8. Help screen.....	22
5 Measurements	23
5.1 Insulation resistance.....	23
5.2 Continuity.....	25
5.2.1 R low test.....	25
5.2.2 Continuity test.....	28
5.3 Testing RCDs	31
5.3.1 Limit contact voltage	31



5.3.2	Nominal differential trip-out current	31
5.3.3	Multiplier of nominal residual current	31
5.3.4	RCD type and test current starting polarity.....	31
5.3.5	Testing selective (time-delayed) RCDs	32
5.3.6	Contact voltage.....	32
5.3.7	Trip-out time.....	34
5.3.8	Trip-out current	36
5.3.9	Autotest	38
5.3.9.1	How to perform RCD autotest.....	38
5.3.10	WARNINGS	43
5.4	Fault loop impedance and prospective fault current	43
5.4.1	Fault loop impedance	43
5.4.2	The fault loop impedance test RCD (for RCD protected circuits).....	45
5.4.3	The fault loop impedance test Rs (for adjustable current)	47
5.5	Line impedance and prospective short-circuit current	48
5.5.1	Voltage drop test	50
5.6	Phase sequence testing	53
5.7	Voltage and frequency	54
5.8	Earth Resistance [Voltcraft IST 3000 only]	56
5.8.1.	Earth Resistance (Re) - 3-wire, 4wire	56
5.8.2.	Specific earth resistance (Ro)	58
6	Maintenance	60
6.1.	Replacing fuses.....	60
6.2.	Cleaning.....	60
6.3.	Periodic calibration.....	60
6.4.	Service	60
6.5.	Batteries	61
7	Technical specifications	62
7.1	Insulation resistance.....	62
7.2	Continuity resistance	62
7.2.1	Low R (depends on model).....	62
7.2.2	Low current continuity	63
7.3	RCD testing	63
7.3.1	General data	63
7.3.2	Contact voltage.....	64
7.3.3	Trip-out time.....	64
7.3.4	Trip-out current	64
7.4	Fault loop impedance and prospective fault current.....	65
7.5	Line impedance and prospective short-circuit current	66



7.6	Phase rotation	66
7.7	Voltage and frequency	66
7.8	Earth Resistance	67
7.9	General data	68
8	Storing measurements [Voltcraft IST 3000 only]	69
8.1.	Overview.....	69
8.2.	Saving results.....	70
8.3.	Recalling results.....	72
8.4.	Deleting results.....	73
9	USB communication [Voltcraft IST 3000 only]	75
9.1.	MFT Records - PC software	75
9.2.	Downloading records to PC.....	75
	Disposal	80
	IST 3000E EVSE Active Test Lead	81
	References marked on instrument or in instruction manual.....	81
	Safety references.....	82
	Testing82	
	Purpose of the EVSE Active Test Lead accessory	82
	Test procedure:	82
	Proximity Pilot (PP) State (Cable Simulation)	83
	Control Pilot (CP) State (Vehicle Simulation)	83
	CP Signal output terminals	83
	CP Error "E" simulation.....	83
	Measuring terminals.....	83
	Cleaning.....	83
	Specifications.....	84



Introduction

Thank you for purchasing this product.

If there are any technical questions, please contact: www.conrad.com/contact

Operating Instructions for download



Use the link www.conrad.com/downloads (alternatively scan the QR code) to download the complete operating instructions (or new/current versions if available). Follow the instructions on the web page.

Intended use

The product is a professional handheld Multi Function Tester (MFT) test instrument intended to perform all the measurements required for verification of electrical safety of installations in buildings.

The user must read and understand these instructions to use the product safely and effectively.

In these instructions, the terms “Multi Function Tester (MFT)”, “product”, “instrument”, “test instrument” all refer to this multi-function test instrument unless otherwise stated.

The following measurements and tests can be performed:

- Continuity tests
- Insulation resistance tests
- RCD testing
- Line / Loop impedance (with Loop RCD option) measurements
- Voltage and frequency
- Phase rotation
- Earth resistance (optional)
- EVSE measurements (optional)
- TFT colour display with backlight

The instrument is equipped with all accessories required in order to perform testing comfortably.

The soft carrying bag, included with the meter, protects the instrument and keeps all accessories together making it simple and easy to move between locations.

The product is intended for indoor use only. Do not use it outdoors. Contact with moisture must be avoided under all circumstances.

If you use the product for purposes other than those described, the product may be damaged. Improper use can result in short circuits, fires, electric shocks or other hazards. The product complies with the statutory national and European requirements. For safety and approval purposes, you must not rebuild and/or modify the product.

Read the operating instructions carefully and store them in a safe place. Make this product available to third parties only together with the operating instructions.

All company names and product names are trademarks of their respective owners. All rights reserved.

USB4®, USB Type-C® and USB-C® are registered trademarks of USB Implementers Forum.





Delivery contents

Item no. 2997218	Item no. 2997219	Item no. 2997220
Multi Function Tester Test leads (1 m) Protective contact plug test cable 3x Test probes (1 m) 3x Alligator clips Shoulder strap Carrying bag USB cable Power adapter 6x AA Ni-MH rechargeable batteries Operating instructions	Multi Function Tester 3x Test leads (1 m) Protective contact plug test cable 3x Test probes (1 m) 3x Alligator clips Shoulder strap Carrying bag USB cable Power adapter 6x AA Ni-MH rechargeable batteries Active test leads Operating instructions	Multi Function Tester Test leads (1 m) Protective contact plug test cable 3x Test probes (1 m) 3x Alligator clips Shoulder strap 6x 1.5 V AA batteries Operating instructions

1. Safety and operational considerations

2.1 Warnings and notes

To maintain the highest level of operator safety while carrying out various tests and measurements, Voltcraft strongly recommends keeping your VOLTCRAFT IST series instruments in best possible condition and undamaged. When using the instrument, consider the following general warnings:

- The  symbol means »Mark on your equipment certifies that it meets requirements of all subjected EU regulations. «
- The  symbol on the instrument means »Read the Instruction manual with special care for safe operation«. The symbol requires an action!
- The  symbol means »Danger: risk of high voltage! «
- The  symbol means »Class II: Double Insulated«. No need for safety connection to Earth.
- If the test equipment is used in a manner not specified in this user manual, the protection provided by the equipment could be impaired!
- Read this user manual carefully, otherwise the use of the instrument may be dangerous for the operator, the instrument or for the equipment under test!
- Stop using the instrument or any of the accessories if any damage is noticed!
- If a fuse blows in the instrument, follow the instructions in this manual in order to replace it!
- Consider all generally known precautions in order to avoid risk of electric shock while dealing with hazardous voltages!
- Do not use the instrument in supply systems with voltages higher than 550 V!
- Service intervention or adjustment is only allowed to be carried out by competent authorized personnel!
- Use only standard or optional test accessories supplied by your distributor!
- [For models that can operate with rechargeable Ni-MH battery cells] The cells should only be replaced with the same type as defined on the battery compartment label or as described in this manual. Do not use standard alkaline battery cells while the power supply adapter is connected, otherwise they may explode!
- Hazardous voltages exist inside the instrument. Disconnect all test leads, remove the power supply cable and switch off the instrument before removing battery compartment cover.
- All normal safety precautions must be taken in order to avoid risk of electric shock while working on electrical installations!

Warnings related to measurement functions

Insulation resistance

- ❑ Insulation resistance measurement should only be performed on de-energized objects!
- ❑ When measuring the insulation resistance between installation conductors, all loads must be disconnected, and all switches closed!
- ❑ Do not touch the test object during the measurement or before it is fully discharged! Risk of electric shock!
- ❑ Do not connect test terminals to external voltage higher than 550 V (AC or DC) in order not to damage the test instrument!

Continuity functions

- ❑ Continuity measurements should only be performed on de-energized objects!
- ❑ Parallel impedances or transient currents may influence test results.

Testing PE terminal

- ❑ If phase voltage is detected on the tested PE terminal, stop all measurements immediately and ensure the cause of the fault is eliminated before proceeding with any activity!

Notes related to measurement functions

General

- ❑ The “!” indicator means that the selected measurement cannot be performed because of irregular conditions on input terminals.
- ❑ Insulation resistance, continuity functions and earth resistance measurements can only be performed on de-energized objects.
- ❑ PASS / FAIL indication is enabled when limit is set. Apply appropriate limit value for evaluation of measurement results.
- ❑ In the case that only two of the three wires are connected to the electrical installation under test, only voltage indication between these two wires is valid.

Insulation resistance

- ❑ If voltages of higher than 10 V (AC or DC) are detected between test terminals, the insulation resistance measurement will not be performed.

Continuity functions

- ❑ If voltages of higher than 10 V (AC or DC) are detected between test terminals, the continuity resistance test will not be performed.
- ❑ Before performing a continuity measurement, where necessary, compensate test lead resistance.

RCD functions

- ❑ Parameters set in one function are also kept for other RCD functions!
- ❑ The measurement of contact voltage does not normally trip an RCD. However, the trip limit of the RCD may be exceeded because of leakage current flowing to the PE protective conductor or a capacitive connection between L and PE conductors.
- ❑ The RCD trip-lock sub-function (function selector switch in **LOOP** position) takes longer

to complete but offers much better accuracy of fault loop resistance (in comparison to the R_L sub-result in **Contact voltage** function).

- ❑ RCD trip-out time and RCD trip-out current measurements will only be performed if the contact voltage in the pre-test at nominal differential current is lower than the set contact voltage limit!
- ❑ The auto-test sequence (RCD AUTO function) stops when trip-out time is out of allowable time period.

Loop impedance (with Loop RCD and / or Loop Rs option)

- ❑ Isc depends on Z, Un and scaling factor
- ❑ The current limit depends on fuse type, fuse current rating, fuse trip-out time
- ❑ The specified accuracy of tested parameters is valid only if the mains voltage is stable during the measurement.
- ❑ Fault loop impedance measurements will trip an RCD.
- ❑ The measurement of fault loop impedance using trip-lock function does not normally trip an RCD. However, the trip limit may be exceeded as a result of leakage current flowing to the PE protective conductor or a capacitive connection between L and PE conductors.

Line impedance

- ❑ Isc depends on Z, Un and scaling factor
- ❑ The current limit depends on fuse type, fuse current rating, fuse trip-out time
- ❑ The specified accuracy of tested parameters is valid only if the mains voltage is stable during the measurement.

2.2 Batteries



When connected to an installation, the instruments battery compartment can contain hazardous voltage inside! When replacing battery cells or before opening the battery/fuse compartment cover, disconnect any measuring accessory connected to the instrument and turn off the instrument,

Only items no. 2997218, 2997219 are allowed to be used with rechargeable batteries

- ❑ Ensure that the battery cells are inserted correctly otherwise the instrument will not operate and the batteries could be discharged.
- ❑ If the instrument is not to be used for a long period of time, remove all batteries from the battery compartment.
- ❑ Do not recharge alkaline battery cells!
- ❑ (Rechargeable) batteries must be kept out of reach of children. Do not leave (rechargeable) batteries lying around, as there is risk, that children or pets swallow them.
- ❑ All (rechargeable) batteries should be replaced at the same time. Mixing old and new (rechargeable) batteries in the device can lead to (rechargeable) battery leakage and device damage.
- ❑ (Rechargeable) batteries must not be dismantled, short-circuited or thrown into fire. Never recharge nonrechargeable batteries. There is a risk of explosion!

2.3 Charging [Internal recharging Voltcraft IST 3000 only]

The batteries will begin charging whenever the power supply adapter is connected to the instrument. The built-in protection circuits control the charging procedure and assure maximum battery lifetime. The power supply socket polarity is shown in figure 2.1.



Figure 2.1: Power supply socket polarity

Note:

Use only power supply adapter delivered from the manufacturer or distributor of the test equipment to avoid possible fire or electric shock!

2.4 Precautions on charging of new battery cells or cells unused for a longer period

Unpredictable chemical processes can occur during the charging of new battery cells or cells that have been left unused for long periods of time (more than 3 months).

When using an external intelligent battery charger, one complete discharging/charging cycle can be performed automatically. After performing this procedure, a normal battery capacity should be fully restored, and the operating time of the instrument will approximately meet the data set out in the in the technical specification.

Notes:

- ❑ The charger in the instrument is a pack cell charger. This means that the cells are connected in series during the charging so all of them must be in similar state (similarly charged, same type and age).
- ❑ If even one deteriorated battery cell (or just one of a different type e.g. capacity, chemical design) can cause disrupted charging of the entire battery pack which could lead to overheating of the battery pack and a significant decrease in the operating time.
- ❑ If no improvement is achieved after performing several charging/discharging cycles, the state of each individual battery cells should be determined (by comparing battery voltages, checking them in a cell charger, etc). It is very likely that one or more of the battery cells could have deteriorated.
- ❑ The effects described above should not be mixed with the normal battery capacity decrease over time. All charging batteries lose some of their capacity when repeatedly charged/discharged. The actual decrease in capacity compared to the number of charging cycles depends on the battery type. This information is normally provided in the technical specification from battery manufacturer.

2.5. Standards applied

The product is manufactured and tested in accordance with the following regulations:
Electromagnetic compatibility (EMC)

EN 61326	Electrical equipment for measurement, control and laboratory use – EMC requirements Class B (Hand-held equipment used in controlled EM environments)
<i>Safety (LVD)</i>	
EN 61010-1	Safety requirements for electrical equipment for measurement, control and laboratory use – Part 1: General requirements
EN 61010-031	Safety requirements for hand-held probe assemblies for electrical measurement and test
<i>Functionality</i>	
EN 61557	Electrical safety in low voltage distribution systems up to 1000 V _{AC} and 1500 V _{AC} – Equipment for testing, measuring or monitoring of protective measures Part 1.....General requirements Part 2.....Insulation resistance Part 3.....Loop resistance Part 4.....Resistance of earth connection and equipotential bonding Part 5.....Resistance to earth Part 6.....Residual current devices (RCDs) in TT and TN systems Part 7.....Phase sequence Part 10.....Combined measuring equipment
DIN VDE 0100	
<i>EVSE</i>	
IEC 62955	Residual direct current detecting device (RDC-DD) to be used for mode 3 charging of electric vehicles

Note about EN and IEC standards:

- Text of this manual contains references to European standards. All standards of EN 6XXXX (e.g. EN 61010) series are equivalent to IEC standards with the same number (e.g. IEC 61010) and differ only in amended parts required by European harmonization procedure.

2.6. Model Specifications

Model	Voltcraft IST 1000	Voltcraft IST 3000
Insulation resistance(Chapter 5.1)		
Nominal voltages 50, 100, 250, 500 and 1.000 V DC	X	X
Continuity resistance (Chapter 5.2)		
Low R (200mA)	X	X
Continuity (low current)	X	X
RCD testing (Chapter 5.3)		
Nominal residual currents (mA)	6/10/30/100/300/500/650/1000	6/10/30/100/300/500/650/1000

VOLTCRAFT IST series

Test current shape	A, AC, B, B+, F	A, AC, B, B+, F
RCD Type	G, S	G, S
Contact voltage	X	X
Trip-out time	X	X
Trip-out current	X	X
Fault loop impedance and prospective fault current (Chapter 5.4)		
Zloop L-PE, I _{pf} c	X	X
Zloop L-PE RCD, I _{pf} c, non trip subfunction	X	X
Loop-Rs	X	X
Line impedance and prospective short-circuit current	X	X
Voltage drop detection	X	X
Voltage	0...500V	0...500V
Frequency	10...499Hz	10...499Hz
Earth Resistance (Chapter 5.8)		
RE (3-wire and 4-wire)	-	X
RO	-	X
Special functions		
Memory and Reporting (Excel-Export)	-	X
Rechargeable batteries & charging "on-board"	-	X
Automatic polarity change	X	X
Calibration date reminder	X	X
FW update per USB	X	X
Networks	TT, TN	TT, TN
Ready for external probe with button	X	X

2. Instrument description

2.1. Front panel (depends on model)

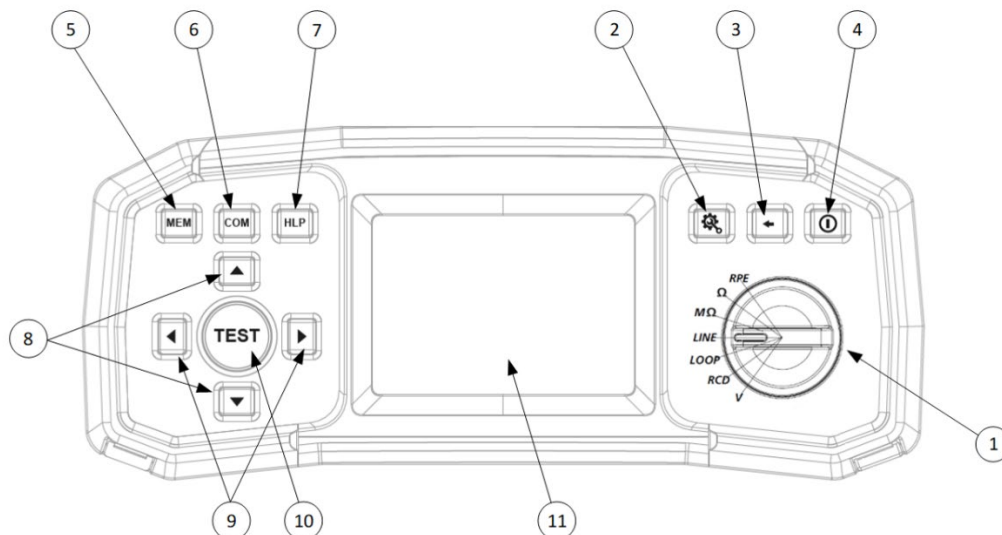

Figure 3.1: Front panel

Legend:

- 1 - Function selector switch
- 2 - Setup key
- 3 - Exit/Back/Return key
- 4 - ON/OFF key, to switch the instrument on and off. The instrument will automatically switch off (APO) after the last key press and no voltage is applied.
- 5 - Memory key
- 6 - Compensation key, to compensate for the test lead resistance in low-value resistance measurements
- 7 - Help key
- 8 - Up and down keys
- 9 - Left and right keys
- 10 - TEST key for starting / confirmation tests
- 11 - TFT color display

2.2. Connector panel (depends on model)

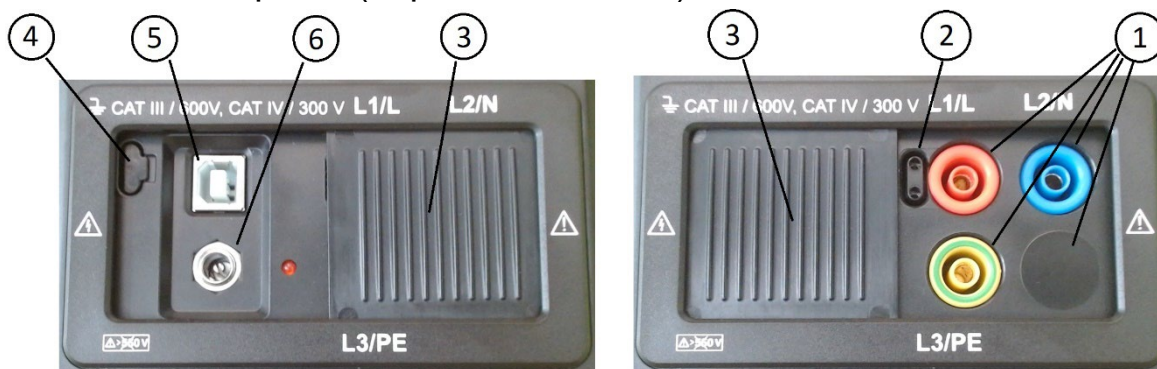

Figure 3.2: Connector panel

Legend:

1 - Test connector.

Warning! Maximum allowed voltage between test terminals and ground is 600V!
Maximal allowed voltage between test terminals is 550 V!

2 - Socket for probe with Test push button

3 - Protection cover above USB- °C B connector

4- USB-C® connector for calibration (depends on model)

5- USB-B connector for data transfer (depends on model)

6 - Battery charger input (depends on model)

2.3. Back panel

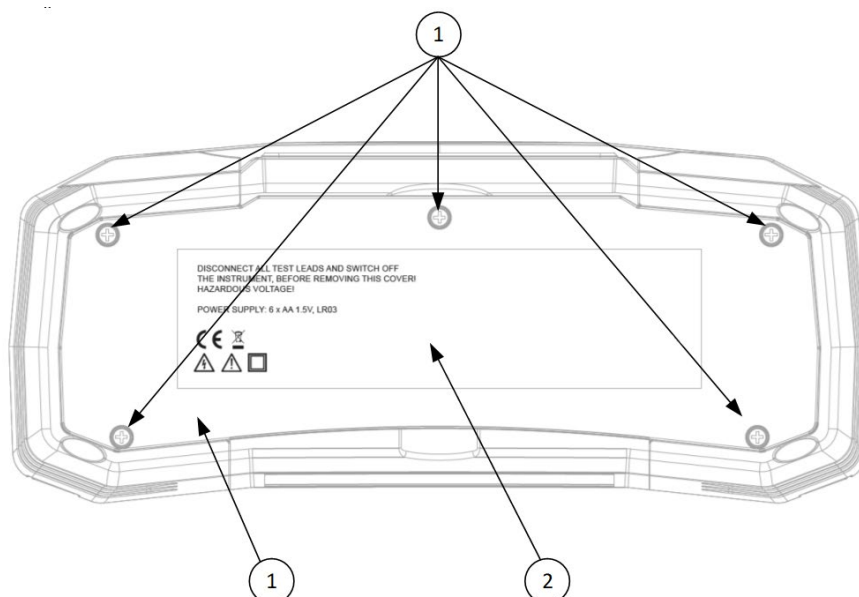

Figure 3.3: Back panel

Legend:

1 - Battery/fuse compartment cover.

2 - Information label.

3 - Fixing screws for battery/fuse compartment cover.

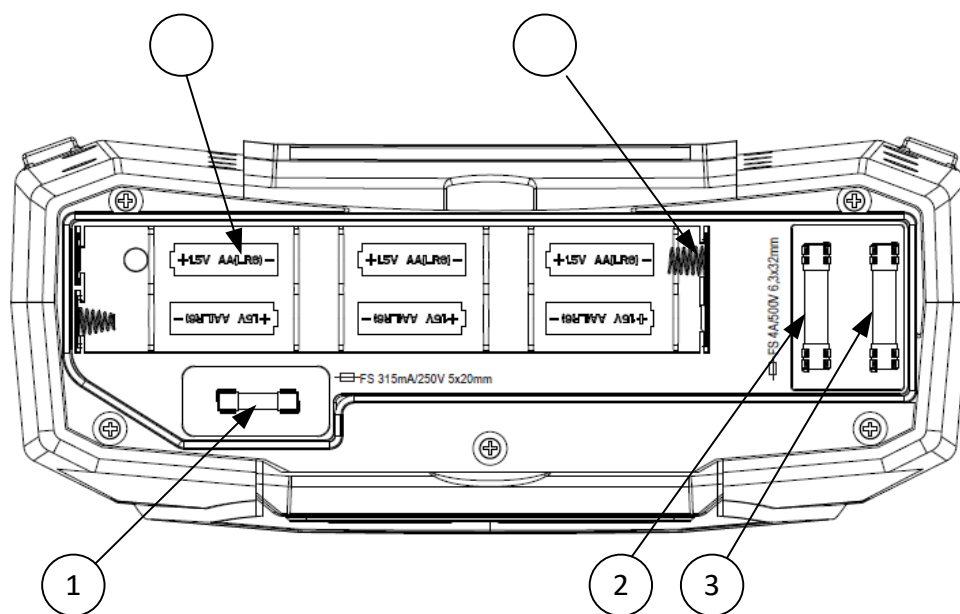

Figure 3.4.: Battery and fuse compartment

Legend:

- 1 Fuse F3.
- 2 Fuse F2.
- 3 Fuse F1.
- 4 Battery cells (size AA).
- 5 Battery contacts.

2.4. Bottom view – Information label

Function	EN61557	range	Accuracy	
Continuity	-4	0.1 Ω ... 20.0 Ω	±(3% of read. + 3 digits)	Test current min. 200mA at 2 Ohm Test current max. 7 mA Open circuit voltage 5V
		0.1 Ω ... 1999 Ω	±(5% of read. + 3 digits)	
Insulation resistance	-2	0.1 MΩ ... 199.9 MΩ 0.1 MΩ ... 199.9 MΩ 200 MΩ ... 999 MΩ	±(5% of read. + 3 digits) ±(2% of read. + 3 digits) ±(10% of read.)	50/100/250V 500/1000V max. 15mA
RCD Time Current	-6	0.0 ... 500ms 0.2xIΔN ... 1.1xIΔN (AC) 0.2xIΔN ... 1.5xIΔN (A), (IΔN ≥30 mA) 0.2xIΔN ... 2.2xIΔN (A), (IΔN <30 mA) 0.2xIΔN ... 2.2xIΔN (B)	±3ms ±0.1xIΔN	IΔN 6,10,30,100,300, 500,650,1000mA
Contact voltage		3V ... 99.9V	(-0%/±10%) of read.±5 digits	
Impedance	-3	0.25 Ω ... 9999 Ω 0.25 Ω ... 9999 Ω 0.75 Ω ... 19.99 Ω 20 Ω ... 9999 Ω	±(5% of read. + 5 digits) ±(5% of read. + 5 digits) ±(5% of read. + 10 digits) ±(10% of read.)	Z line L-L,L-N Z loop L-PE Z loop L-PE non-trip Line: 93V-134V; 185V-266V; 321V-485V; 45Hz-65Hz Loop: 93V-134V; 185V-266V; 45Hz-65Hz
Voltage Frequency	-7	0 ... 550V (45-400Hz) 10.0 ... 499.9Hz	±(2% of read. + 2 digits) ±(0.2% + 1 digits)	TRMS
Phase rotation	-7	50 ... 550VAC 45 ... 400Hz		Right:1-2-3 Left:3-2-1
Earth resistance	-5	1.0 Ω ... 9999 Ω 6.0 Ω ... 9999 Ω	±(5% of read. + 5 digits)	3-wire, 4-wire Specific earth resistance f=126.9Hz

Figure 3.5: Bottom panel information label

2.5. Carrying the instrument

The neck strap supplied in standard set allows the instrument to be carried in a variety of different ways. The operator can choose the most appropriate method based on the tasks they are performing.

The instrument can be hung around operator's neck allowing the instrument to move freely. This allows equipment to be moved quickly between test locations.

4. Instrument operation

4.1. Meaning of symbols and messages on the Instrument display

The instrument display is divided into several sections:

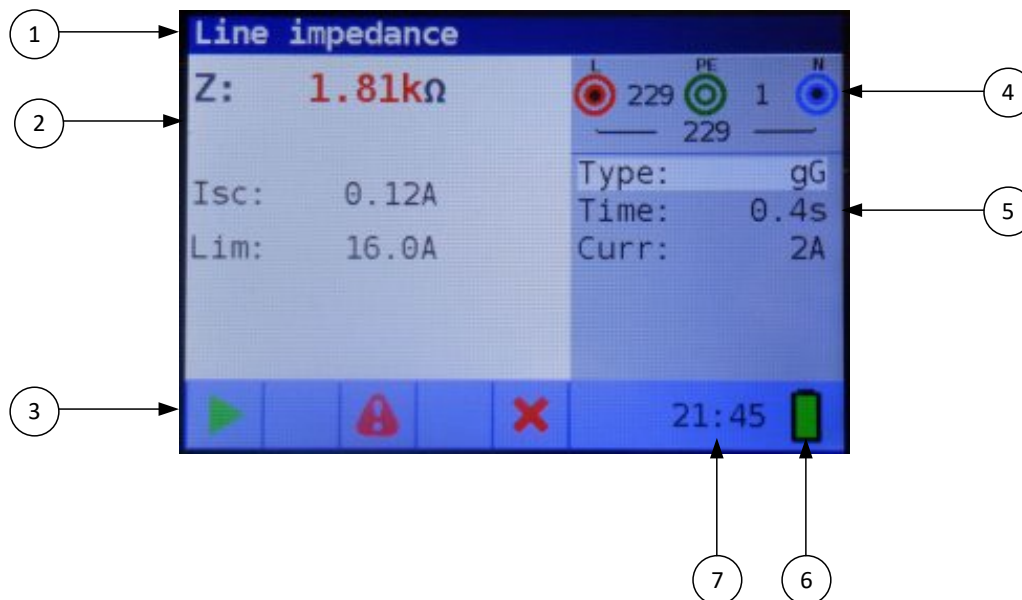
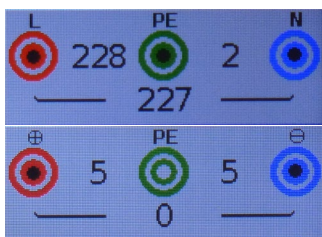

Figure 4.1: Display outlook

Legend:

- 1 - Function line.
- 2 - Result field.
In this field the main result and sub-results are displayed.
- 3 - Status field
PASS/FAIL/ABORT/START/WAIT/WARNINGS status are displayed.
- 4 - Online voltage and output monitor.
Shows symbolized plugs, names the plugs depending on the measurements, always shows the actual voltages.
- 5 - Options field
- 6 - Battery status indication
- 7 - Current time

4.2. The online voltage and output terminal monitor



Online voltages are displayed together with test terminal indication. All three test terminals are used for selected measurement.

Online voltages are displayed together with test terminal indication. L and N test terminals are used for selected measurement.

4.3. Message field – battery status



Battery power indication.



Low battery indication. Battery pack is too weak to guarantee correct result. Replace the batteries.

Recharging is shown by a LED near the supply socket.

4.4. Status field – measurement warnings/results symbols

Symbol	Meaning	Active in function:												
		Voltage Rotation	R low	Continuity	R Isolation	Line	Loop	Loop RCD	RCD time	RCD current	RCD auto	RCD Uc	Earth resistance	
	Dangerous voltage	X	X	X	X	X	X	X	X	X	X	X	X	X
COMP	Test leads are compensated		X	X										
	Measurement cannot be started		X	X	X									
	Dangerous voltage on PE	X	X	X	X	X	X	X	X	X	X	X	X	X
	Result is not ok		X	X	X	X	X	X	X	X	X	X	X	X
	Result is ok		X	X	X	X	X	X	X	X	X	X	X	X
	RCD open or tripped								X	X	X	X		
	RCD closed								X	X	X	X		
	Measurement can be started		X	X	X	X	X	X	X	X	X	X	X	X
	Temperature too high					X	X	X	X	X	X	X		
	Swap test leads	X	X	X	X	X	X	X	X	X	X	X	X	X
	Wait				X									
	Noise on signal					X	X	X	X	X	X	X		
	Check fuses		X	X	X									X
REF	Reference measurement (optional)					X								
SF	Single fault in IT system (optional)	X				X	X	X	X	X	X	X		

Figure 4-1 List of status symbols

4.5. Sound warnings

- Short high sound button pressed
- continued sound during continuity test when result is <35 Ohm
- upwards sound attention, dangerous voltage applied
- Short sound power off, end of measurement
- downwards sound warnings (temperature, voltage at input, start not possible)

Periodic sound **Warning!** Phase voltage on the PE terminal! Stop all the measurements immediately and eliminate the fault before proceeding with any activity!

4.6. Performing measurement

4.6.1. Measurement function/ sub-function

The following measurements can be selected with the function selector switch:

- Voltage/rotation/frequency measurement
- Earth resistance
- R Low
- R Insulation
- Line impedance
- Loop (Loop RCD) impedance
- RCD
- EVSE measurement (option)

The function/sub-function name is highlighted on the display by default.

4.6.2. Selecting measurement function/ sub-function

Using navigation keys ▲▼ select the parameter/limit value you want to edit. By using ◀▶ keys the value for the selected parameter can be set.

Once the measurement parameters are set, the settings are retained until new changes are made.

4.6.3. Performing tests

When ► symbol is displayed test can be started by pressing the “TEST” button. After completion of the test its result value and status will be displayed. In case of PASSED measurement, result value will be displayed in black color along with the ✓ status symbol. In case of NOT PASSED measurement, the result value will be marked in red color along with the ✗ symbol.

4.7. Setup menu

To enter the **Setup** menu, press the SETUP key. In the **Setup** menu, the following actions can be taken:

- Isc factor:
 - Set prospective short/fault current scaling factor
- Date/Time:
 - Set internal date and time
 - Calibration date (optional)
- RCD standard:
 - Select national standard for RCD testing, e.g EN61008 or BS7671

- ELV:
Select voltage for ELV warning.
- Power off time:
Select time when device should switch off if not used.
- Cont timeout:
Select time-out when measurement should stop automatically.
- ISO timeout:
Select time-out when measurement should stop automatically.
- Supply system:
Select supply network/system, e.g. TN or IT.
- Device info:
Shows info about device, e.g. Firmware version
- Language:
Set the language
- Buzzer:
Set the options, when the buzzer should be active
- Backlight:
Set the level of the TFT display backlight

4.8. Help screen

The Help screens contain diagrams that show the correct use of the device.

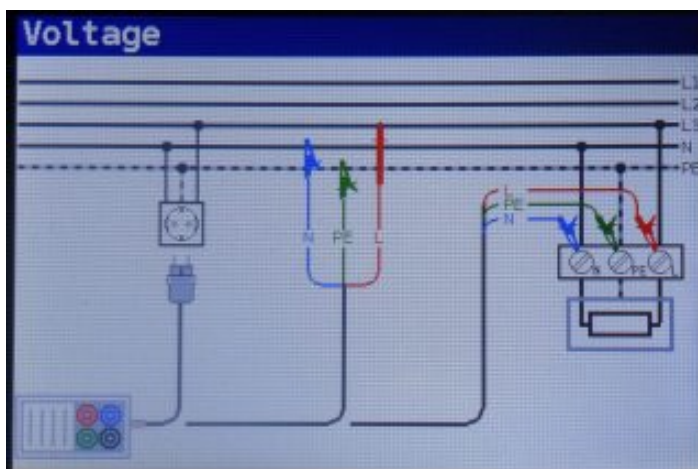

Figure 4-8: example of a help screen

Press the HLP key to enter the help screen

Press the HLP key or the Exit/Back/Return key to exit the help screen

Press the Left and Right keys to switch to previous/next help screen

5 Measurements

5.1 Insulation resistance

The Insulation resistance measurement is performed in order to ensure safety against electric shock. Using this measurement, the following items can be determined:

- Insulation resistance between installation conductors,
- Insulation resistance of non-conductive rooms (walls and floors),
- Insulation resistance of ground cables,
- Resistance of semi-conductive (antistatic) floors.

How to perform an insulation resistance measurement

Step 1 Select **Insulation** function with the function selector switch. The following menu is displayed:

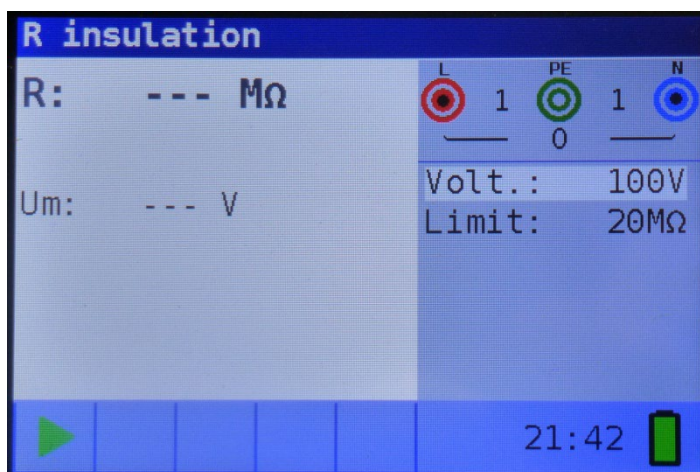

Figure 5-1: Insulation resistance measurement menu

Step 2 Set the following measuring parameter and limit values:

- Volt:** Nominal test voltage,
- Limit:** Low limit resistance value.

Step 3 Ensure that no voltages are present on the item for testing. Connect the test leads to the VOLTCRAFT IST instrument. Connect the test cables to the item under test. (see figure 5.2) to perform insulation resistance measurement.

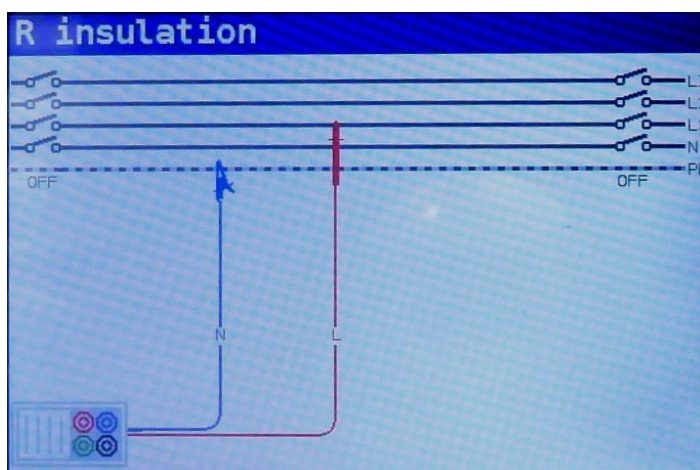

Figure 5-2: Connection of universal test cable

Step 4 Check the displayed warnings and online voltage/terminal monitor before starting the measurement. If ► is displayed, press the TEST key. After the test is done, measured results are displayed, together with the ✓ or ✗ indication (if applicable).

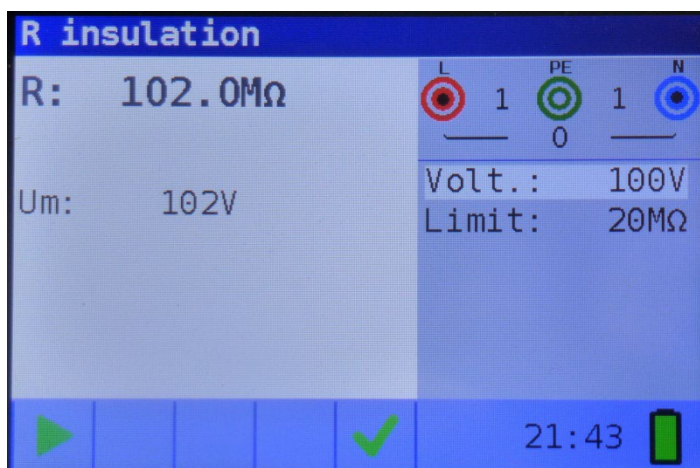

Figure 5-3: Example of insulation resistance measurement results

Displayed results:

RInsulation resistance,
UmActual voltage applied to item under test

Warnings:

- ❑ Insulation resistance measurement should only be performed on de-energized objects!
- ❑ When measuring the insulation resistance between installation conductors, all loads must be disconnected and all switches closed!
- ❑ Do not touch the test object during the measurement or before it is fully discharged! Risk of electric shock!
- ❑ In order to prevent damaging the test instrument, do not connect test terminals to an external voltage higher than 550 V (AC or DC).

5.2 Continuity

Two continuity sub-functions are available:

- ❑ R Low, ca. 240mA continuity test with automatic polarity reversal.
- ❑ Low current (ca. 4mA) continuous continuity test (optional), useful when testing inductive systems.

5.2.1 R low test

This function is used to test the resistance between two different points of the installation to ensure that a conductive path exists between them. The test ensures that all protective conductors, earth conductors or bonding conductors are correctly connected, terminated and have the correct resistive value.

The measurement of the R Low resistance is performed with a test current of more than 200mA@20hm. An automatic pole reversal of the test voltage and the test current is performed during the test. This test checks for any components (e.g. diodes, transistors, SCRs) that may have a rectifying effect on the circuit which could cause problems when a voltage is applied.

This measurement completely complies with EN61557- 4 regulations.

How to perform a R Low resistance measurement

- Step 1** Select the **Continuity** function with the function selector switch and select the R Low mode with the ▲ ▼ and ◀▶ navigation keys. The following menu will be displayed:

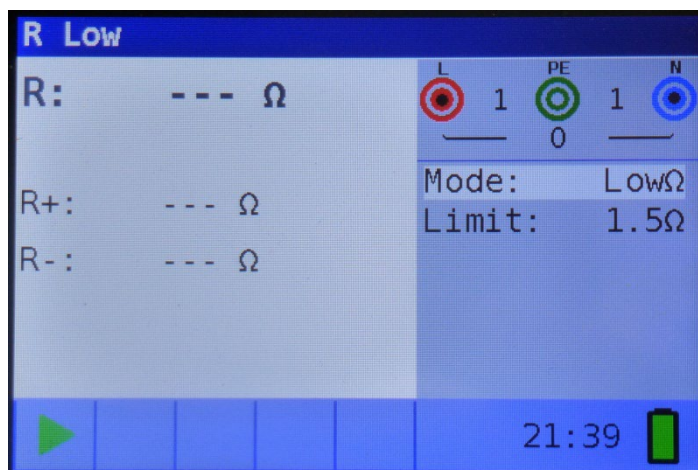

Figure 5-4: R Low resistance measurement menu

- Step 2** Set the following limit value:
- ❑ **Limit:** limit resistance value using the ▲ ▼ and ◀▶ navigation keys.

- Step 3** Connect test cable to the instrument. Before performing an R Low resistance measurement, compensate for the test leads resistance as follows:

1. Short test leads first as shown in figure 5.5.

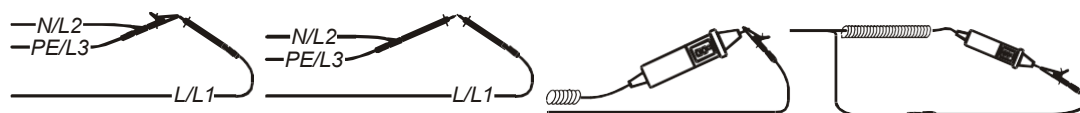





Figure 5-5: Shorted test leads

- 2 Press the COM key. After performing test leads compensation the compensated test leads indicator **COMP** will be displayed in the status line.
2. In order to remove any test lead resistance compensation, just press the COM key again. After removing any test lead compensation, the compensation indicator will disappear from the status line.

Step 4 Ensure that the item for testing is disconnected from any voltage source and it has been fully discharged. Connect the test cables to the item under test. Follow the connection diagrams shown in figures 5.6 and 5.7 to perform a R Low resistance measurement.



Figure 5-6: Connection of universal test cable

Step 5 Check for any warnings and the online voltage/terminal monitor on the display before starting the measurement. If everything is ok and the  is shown, press the TEST key. After performing the measurement, the results appear on the display together with the  or  indication (if applicable).

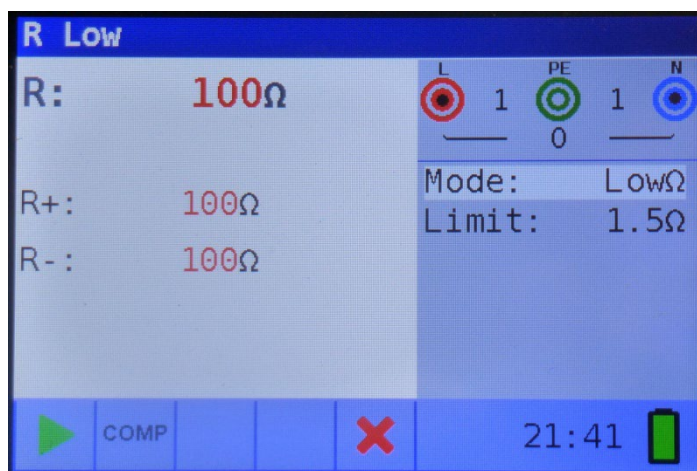

Figure 5-7: Examples of R Low resistance measurement results

Displayed results:

- R**Main Low Ω resistance result (average of R+ and R- results),
- R+**Low Ω resistance sub-result with positive voltage at L terminal,
- R-**Low Ω resistance sub-result with positive voltage at N terminal.

Warnings:

- Low-value resistance measurements should only be performed on de-energized objects!
- Parallel impedances or transient currents may influence test results.

Note:

- If voltage between test terminals is higher than 10 V the R Low measurement will not be performed.

5.2.2 Continuity test

Continuous low-value resistance measurements can be performed without pole reversal of the test voltages and a lower test current (a few mA). In general, the function serves as an ordinary Ω -meter with low-test current. The function can also be used to test inductive components such as motors and coiled cables.

How to perform low current continuity measurement

- Step 1** Select the **Continuity** function with the function selector switch and select the **Cont** mode with the \blacktriangle \blacktriangledown and \blacktriangleleft \blacktriangleright navigation keys. The following menu will be displayed:

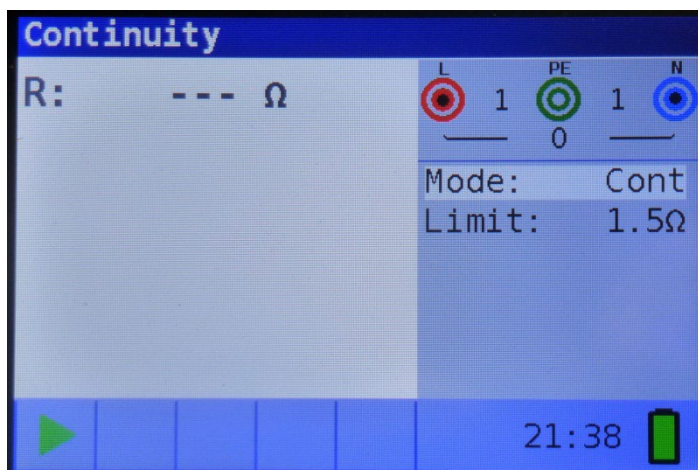

Figure 5-8: Continuity measurement menu

- Step 2** Set the following limit value:
- **Limit:** limit resistance value using the \blacktriangle \blacktriangledown and \blacktriangleleft \blacktriangleright navigation keys.
- Step 3** Connect test cable to the instrument and the item under test. Follow the connection diagram shown in figures 5.10 and 5.11 to perform the **Continuity** measurement.

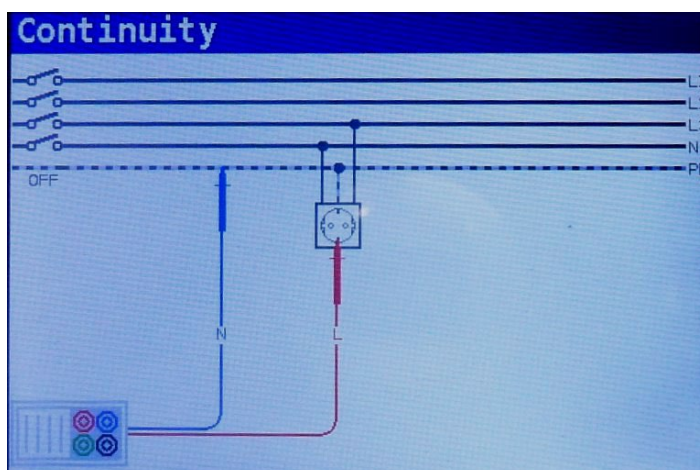







Figure 5-9: Connection of universal test cable

Step 4 Check the warnings and online voltage/terminal monitor on the display before starting the measurement. If everything is OK and the  is shown, press the TEST key to start the measurement. The actual measuring result with  or  indication (if applicable) will be displayed during the measurement. As this is a continuous test, the function will require stopping. To stop the measurement at any time press the TEST key again. The last measured result will be displayed together with the  or  indication (if applicable).

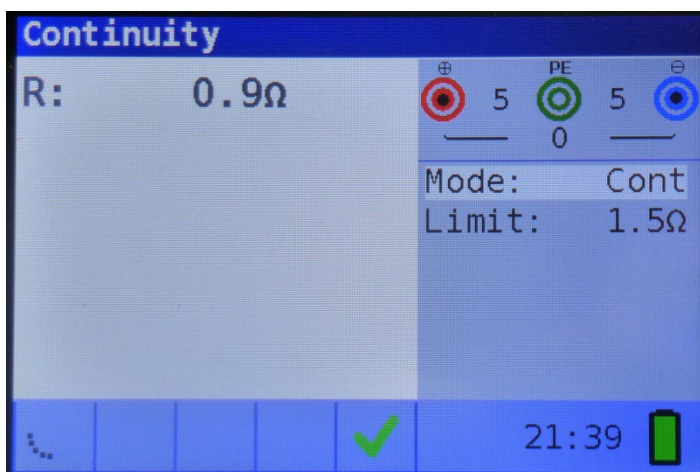

Figure 5-10: Example of Low current continuity measurement result

Displayed result:

RLow current continuity resistance result.

I Current used in the measurement

Warning:

- ❑ Low current continuity measurement should only be performed on de-energized objects!

Notes:

- If a voltage of higher than 10 V exists between test terminals, the continuity measurement will not be performed.
Before performing a continuity measurement, compensate for the test lead resistance (if necessary).

5.3 Testing RCDs

When testing RCDs, the following sub-functions can be performed:

- ❑ Contact voltage measurement,
- ❑ Trip-out time measurement,
- ❑ Trip-out current measurement,
- ❑ RCD autotest.

In general, the following parameters and limits can be set when testing RCDs:

- ❑ Limit contact voltage,
- ❑ Nominal differential RCD trip-out current,
- ❑ Multiplier of nominal differential RCD trip-out current,
- ❑ RCD type,
- ❑ Test current starting polarity.

For possible parameters that could be set look into specification tables at the end of this manual.

5.3.1 Limit contact voltage

Safety contact voltage is limited to 50 V_{AC} for standard domestic area. In special environments (hospitals, wet places, etc.) contact voltages up to 25 V_{AC} are permitted. Limit contact voltage can be set in contact voltage **Uc** function only!

5.3.2 Nominal differential trip-out current

Nominal differential current is the rated trip-out current of an RCD. The following RCD current ratings can be set: 6 mA (*), 10 mA, 30 mA, 100 mA, 300 mA, 500 mA , 650 mA (*) and 1000 mA (*). (* optional)

5.3.3 Multiplier of nominal residual current

Selected nominal differential current can be multiplied by ½, 1, 2 or 5.

5.3.4 RCD type and test current starting polarity

The VOLTCRAFT instrument enables testing of general (non-delayed) and selective (time-delayed) RCDs. The types of RCD the instrument is suitable for testing include:

- Alternating residual current (AC type), 
- Pulsating DC residual current (A type).
- pure or nearly pure DC residual current (B type) (depends on model).
- special RCDs for EVSE applications.

Test current starting polarity can be started with the positive half-wave at 0° or with the negative half-wave at 180°.



positive start polarity (0°)



negative start polarity (180°)

Figure 5-11: Test current started with the positive or negative half-wave

5.3.5 Testing selective (time-delayed) RCDs

Selective RCDs demonstrate delayed response characteristics. Trip-out performance is influenced due to pre-loading during measurement of contact voltage. In order to eliminate the pre-loading a time delay of 30 s is inserted before performing the trip-out test.

5.3.6 Contact voltage

Leakage current flowing to the PE terminal causes a voltage drop across earth resistance, which is called contact voltage (U_c). This voltage is present on all accessible parts connected to the PE terminal and should be lower than the safety limit voltage.

The parameter contact voltage is measured without tripping-out the RCD. R_L is a fault loop resistance and is calculated as follows:

$$R_L = \frac{U_c}{I_{\Delta N}}$$

Displayed contact voltage relates to the rated nominal differential current of the RCD and is multiplied by a safety factor. See the table 5.1 for detailed contact voltage calculation.





RCD type	Contact voltage U_c
G 	$U_c \propto 1.05 \times I_{\Delta N}$
S  S 	$U_c \propto 1.05 \times 2 \times I_{\Delta N}$
G G	$U_c \propto 1.05 \times \sqrt{2} \times I_{\Delta N}$
S S	$U_c \propto 1.05 \times 2 \times \sqrt{2} \times I_{\Delta N}$

Table 5-1: Relationship between U_c and $I_{\Delta N}$

How to perform contact voltage measurement

Step 1 Select the **RCD** function with the function selector switch and select the **Uc** mode with the  and  navigation keys. The following menu will be displayed:

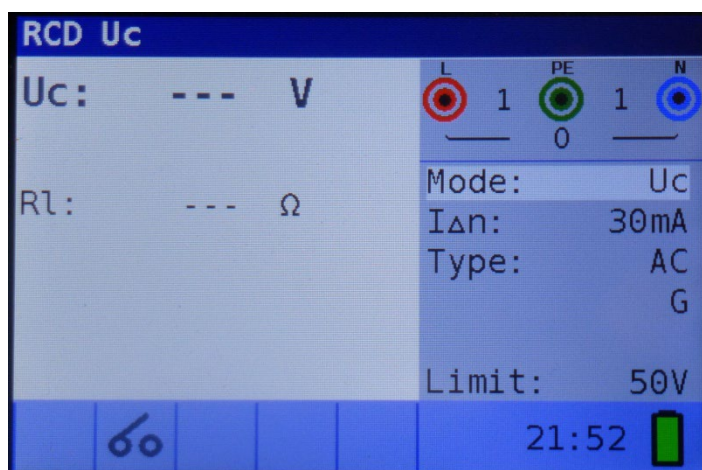

Figure 5-12: Contact voltage measurement menu

Step 2 Set the following measuring parameters and limit values:

- **I_{Δn}**: Nominal residual current,
- **Type**: RCD type,
- **Limit**: Limit contact voltage.

Step 3 Connect the test leads to the instrument and follow the connection diagram shown in figure 5.15 to perform contact voltage measurement.

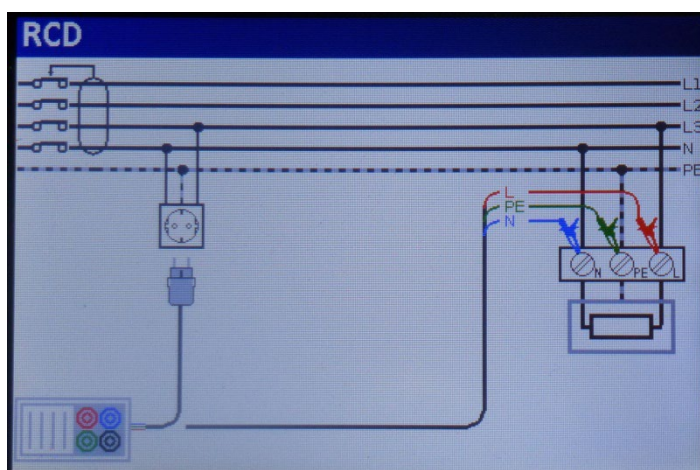

Figure 5-13: Connection of plug test cable or universal test cable

Step 4 Check for any warnings and check the online voltage/terminal monitor on the display before starting the measurement. If everything is ok and the ► is shown, press the TEST key. After performing the measurement, the results appear on the display together with the ✓ or ✗ indication.

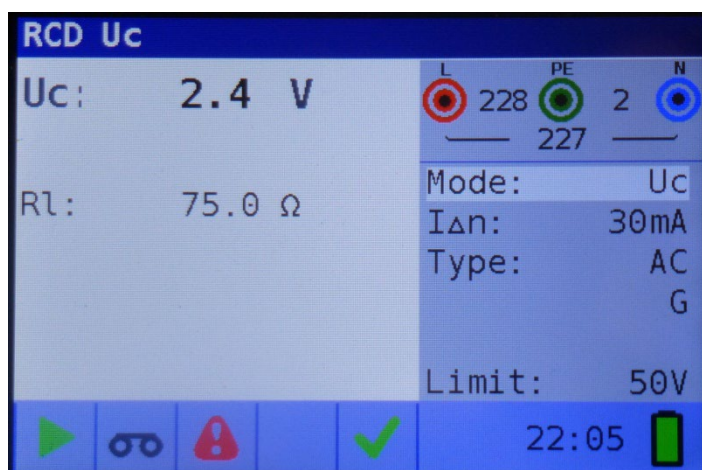

Figure 5-14: Example of contact voltage measurement results

Displayed results:

UcContact voltage.

RIFault loop resistance.

LimitLimit earth fault loop resistance value according to BS 7671.

Notes:

- ❑ Parameters set in this function are also kept for all other RCD functions!
- ❑ The measurement of contact voltage does not normally trip an RCD. However, the trip limit may be exceeded as a result of leakage currents flowing through the PE protective conductor or a capacitive connection between the L and PE conductor.
- ❑ RCD trip-lock sub-function (function selected to **LOOP RCD** option) takes longer to complete but offers much better accuracy of a fault loop resistance result (in comparison with the R_L sub-result in **Contact voltage** function).

5.3.7 Trip-out time

Trip-out time measurement is used to verify the effectiveness of an RCD. This is achieved by a test simulating an appropriate fault condition. Trip-out times vary between standards and are listed below.

Trip-out times according to BS EN 61008 / BS EN 61009:

	$\frac{1}{2} \times I_{\Delta N}$	$I_{\Delta N}$	$2 \times I_{\Delta N}$	$5 \times I_{\Delta N}$
General (non-delayed) RCDs	$t_{\Delta} > 300 \text{ ms}$	$t_{\Delta} < 300 \text{ ms}$	$t_{\Delta} < 150 \text{ ms}$	$t_{\Delta} < 40 \text{ ms}$
Selective (time-delayed) RCDs	$t_{\Delta} > 500 \text{ ms}$	$130 \text{ ms} < t_{\Delta} < 500 \text{ ms}$	$60 \text{ ms} < t_{\Delta} < 200 \text{ ms}$	$50 \text{ ms} < t_{\Delta} < 150 \text{ ms}$

Trip-out times according to BS 7671:

	$\frac{1}{2} \times I_{\Delta N}$	$I_{\Delta N}$	$2 \times I_{\Delta N}$	$5 \times I_{\Delta N}$
General (non-delayed) RCDs	$t_{\Delta} > 1999 \text{ ms}$	$t_{\Delta} < 300 \text{ ms}$	$t_{\Delta} < 150 \text{ ms}$	$t_{\Delta} < 40 \text{ ms}$
Selective (time-delayed) RCDs	$t_{\Delta} > 1999 \text{ ms}$	$130 \text{ ms} < t_{\Delta} < 500 \text{ ms}$	$60 \text{ ms} < t_{\Delta} < 200 \text{ ms}$	$50 \text{ ms} < t_{\Delta} < 150 \text{ ms}$

^{*)} Test current of $\frac{1}{2} \times I_{\Delta N}$ cannot cause trip-out of the RCDs.

Trip-out times according to IEC 62955:

	$I_{\Delta Ndc}$	$10 \times I_{\Delta Ndc}$	$33 \times I_{\Delta Ndc}$	
6 mADC RCDs	$t_{\Delta} < 10.000 \text{ ms}$	$t_{\Delta} < 300 \text{ ms}$	$t_{\Delta} < 100 \text{ ms}$	
	$I_{\Delta N}$	$2 \times I_{\Delta N}$	$5 \times I_{\Delta N}$	$167 \times I_{\Delta N}$
30 mAAC RCDs	no trip	$t_{\Delta} < 300 \text{ ms}$	$t_{\Delta} < 80 \text{ ms}$	$t_{\Delta} < 80 \text{ ms}$

How to perform trip-out time measurement

Step 1 Select the **RCD** function with the function selector switch and select the **Time** mode with the \blacktriangle \blacktriangledown and \blacktriangleleft \blacktriangleright navigation keys. The following menu will be displayed:

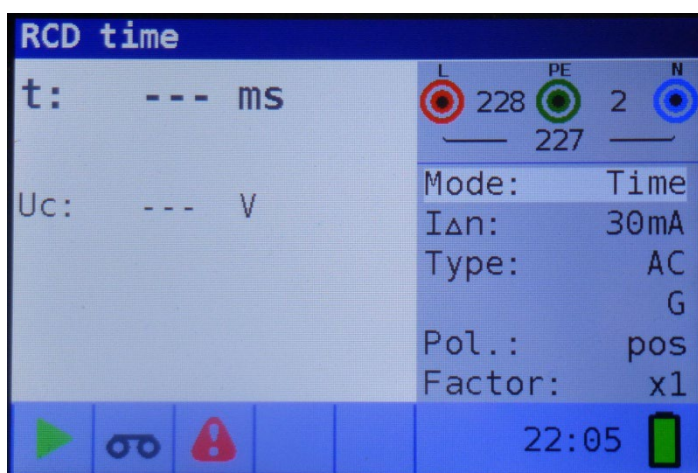

Figure 5-15: Trip-out time measurement menu

Step 2 Set the following measuring parameters:

- **$I_{\Delta N}$** : Nominal differential trip-out current,
- **Factor**: Nominal differential trip-out current multiplier,
- **Type**: RCD type and
- **Pol.**: Test current starting polarity.

Step 3 Connect the leads to the instrument and follow the connection diagram shown in figure 5.15 (see the chapter 5.3.6 *Contact voltage*) to perform trip-out time measurement.

Step 4 Check for any warnings and check the online voltage/terminal monitor on the display before starting the measurement. If everything is ok and the ► is shown, press the TEST key. After performing the measurement, the results appear on the display together with the ✓ or ✗ indication.

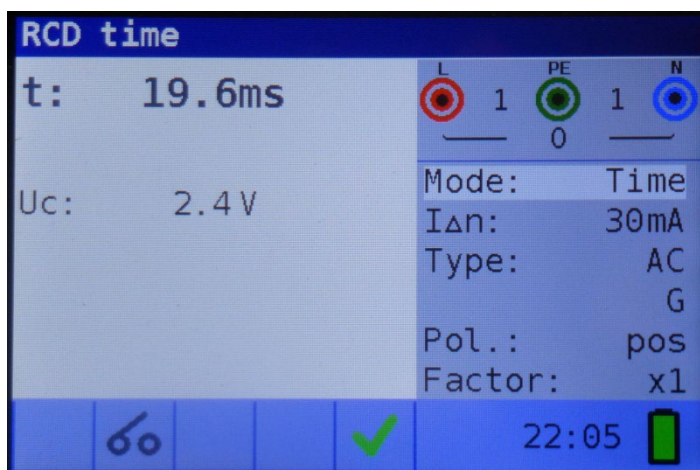

Figure 5-16: Example of trip-out time measurement results

Displayed results:

t.....Trip-out time,
U_c.....Contact voltage.

Notes:

- ❑ Parameters set in this function are also transferred onto all other RCD functions!
- ❑ RCD trip-out time measurement will be performed only if the contact voltage at nominal differential current is lower than the limit set in the contact voltage setting!
- ❑ The measurement of the contact voltage in pre-test does not normally trip an RCD. However, the trip limit may be exceeded as a result of leakage current flowing through the PE protective conductor or a capacitive connection between L and PE conductors.

5.3.8 Trip-out current

This test is used to determine the minimum current required to trip the RCD. After the measurement has been started, the test current generated by the instrument is continuously increased, starting at $0.2 \times I_{\Delta N}$ to $1.1 \times I_{\Delta N}$ (to $1.5 \times I_{\Delta N} / 2.2 \times I_{\Delta N}$ ($I_{\Delta N} = 10 \text{ mA}$) for pulsating DC residual currents), until the RCD trips.

How to perform trip-out current measurement

Step 1 Select the **RCD** function with the function selector switch and select the **Ramp** mode with the ▲▼ and ◀▶ navigation keys. The following menu will be displayed:

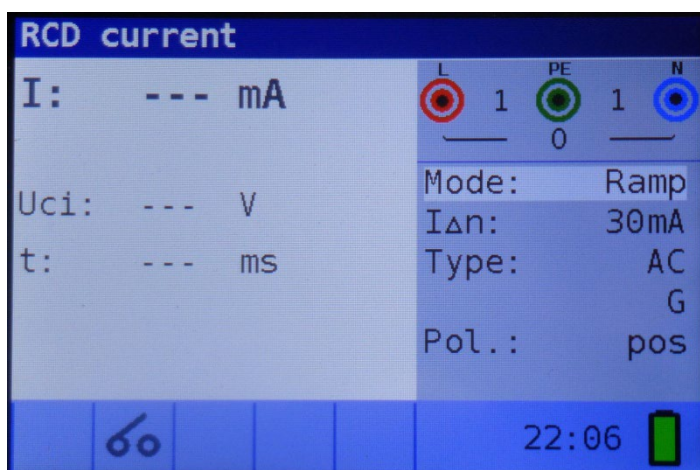

Figure 5-17: Trip-out current measurement menu

Step 2 By using cursor keys the following parameters can be set in this measurement:

- **I_{ΔN}**: Nominal residual current,
- **Type**: RCD type,
- **Pol.:** Test current starting polarity.

Step 3 Connect the test leads to the instrument and follow the connection diagram shown in figure 5.15 (see the chapter 5.3.6 *Contact voltage*) to perform trip-out current measurements.

Step 4 Check for any warnings and check the online voltage/terminal monitor on the display before starting the measurement. If everything is ok and the ► is shown, press the TEST key. After performing the measurement, the results appear on the display together with the ✓ or ✗ indication.

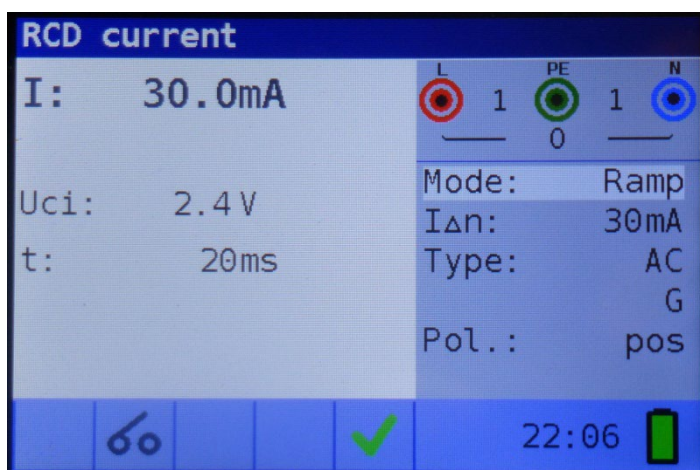

Figure 5-18: Example of trip-out current measurement result

Displayed results:

- I**.....Trip-out current,
- Uci**Contact voltage,
- t**.....Trip-out time.

Notes:

- ❑ Parameters set in this function are also kept for other RCD functions!
- ❑ RCD trip-out current measurement will be performed only if the contact voltage at nominal differential current is lower than set limit contact voltage!
- ❑ The measurement of contact voltage in the pre-test does not normally trip an RCD. However, the trip limit may be exceeded as a result of leakage current flowing through the PE protective conductor or a capacitive connection between L and PE conductors.

5.3.9 Autotest

The purpose of the autotest function is to perform a complete RCD testing and measurement of most important associated parameters (contact voltage, fault loop resistance and trip-out time at different fault currents) with one press of a button. If a faulty parameter is noticed during the autotest, the test will stop to highlight the need for further investigation.

Notes:

- The measurement of contact voltage in the pre-test does not normally trip an RCD. However, the trip limit may be exceeded as a result of leakage current flowing through the PE protective conductor or a capacitive connection between L and PE conductors.
- The autotest sequence stops when the trip-out time is out of allowed time period.

5.3.9.1 How to perform RCD autotest

Step 1 Select the **RCD** function with the function selector switch and select the **Auto** mode with the ▲▼ and ◀▶ navigation keys. The following menu will be displayed:

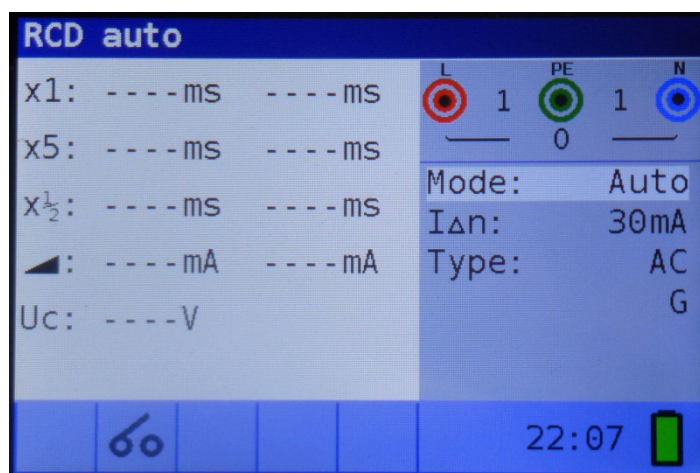



Figure 5-19: RCD autotest menu

Step 2 Set the following measuring parameters:

- **I_{Δn}**: Nominal differential trip-out current,
- **Type**: RCD type.

Step 3 Connect the test leads to the instrument and follow the connection diagram shown in figure 5.15 (also see the chapter 5.3.6 *Contact voltage*) to perform the RCD autotest.

Step 4 Check for any warnings and check the online voltage/terminal monitor on the display before starting the measurement. If everything is ok and the  is shown, press the TEST key. The autotest sequence will then start to run as follows:

1. Trip-out time measurement with the following measurement parameters:
 - Test current of $I_{\Delta N}$,
 - Test current started with the positive half-wave at 0° .

Measurement normally trips an RCD within allowed time period. The following menu is displayed:

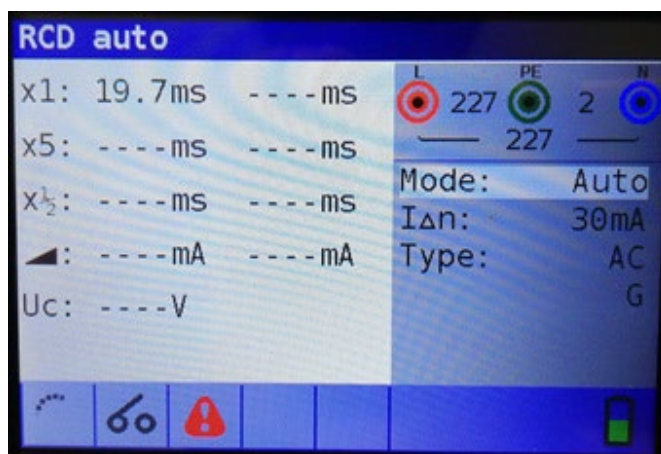

Figure 5-20: Step 1 RCD autotest results

After re-activating the RCD, the autotest sequence automatically proceeds with step 2.

2. Trip-out time measurement with the following measurement parameters:
 - Test current of $I_{\Delta N}$,
 - Test current started with the negative half-wave at 180° .

Measurement normally trips an RCD. The following menu is displayed:

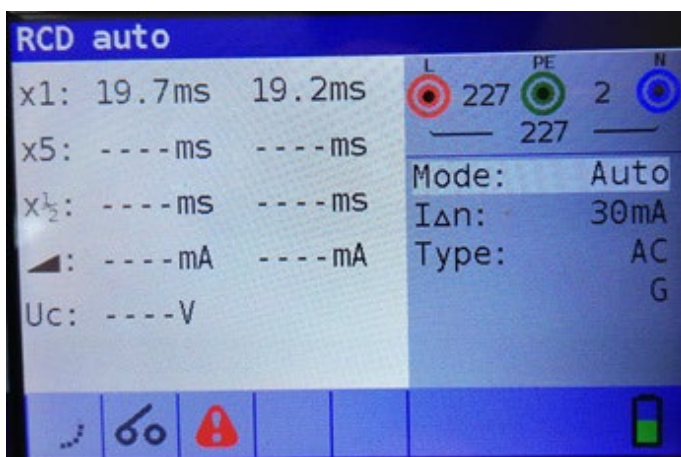

Figure 5-21: Step 2 RCD autotest results

After re-activating the RCD, the autotest sequence automatically proceeds with step 3.

3. Trip-out time measurement with the following measurement parameters:

- Test current of $5 \times I_{\Delta N}$,
- Test current started with the positive half-wave at 0° .

Measurement normally trips an RCD within allowed time period. The following menu is displayed:

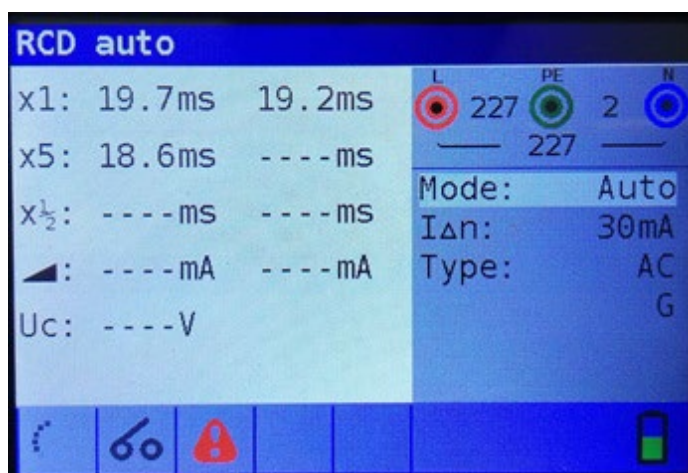

Figure 5-22: Step 3 RCD autotest results

After re-activating the RCD the autotest sequence automatically proceeds with step 4.

4. Trip-out time measurement with the following measurement parameters:

- Test current of $5 \times I_{\Delta N}$,
- Test current started with the negative half-wave at 180° .

Measurement normally trips an RCD within allowed time period. The following menu is displayed:

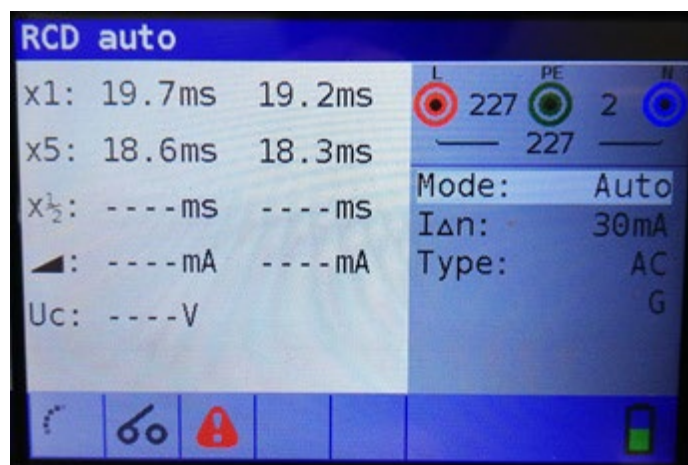

Figure 5-23: Step 4 RCD autotest results

After re-activating the RCD the autotest sequence automatically proceeds with step 5.

5. Trip-out time measurement with the following measurement parameters:

- Test current of $\frac{1}{2} \times I_{\Delta N}$,
- Test current started with the positive half-wave at 0° .

Measurement does not normally trip an RCD. The following menu is displayed:

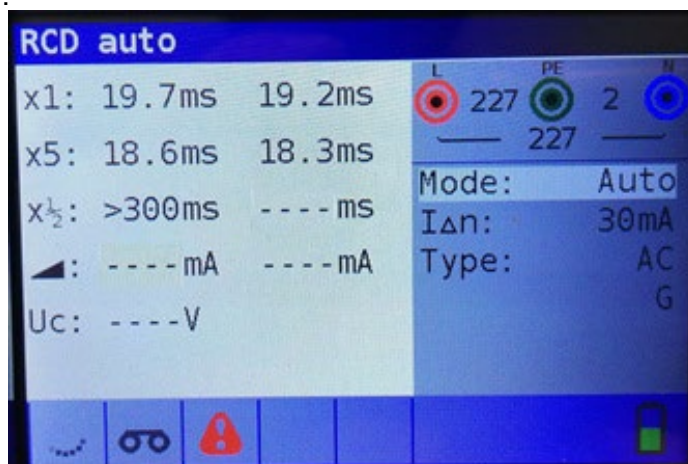

Figure 5-24: Step 5 RCD autotest results

After performing step 5 the RCD autotest sequence automatically proceeds with step 6.

6. Trip-out time measurement with the following measurement parameters:

- Test current of $\frac{1}{2} \times I_{\Delta N}$,
- Test current started with the negative half-wave at 180° .

Measurement does not normally trip an RCD. The following menu is displayed:

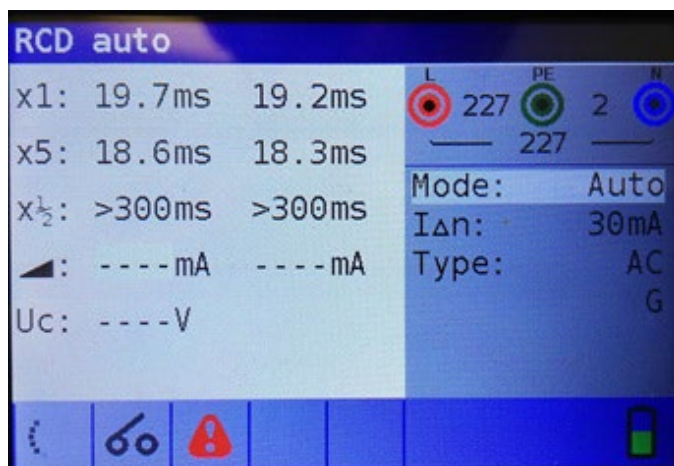

Figure 5-25: Step 6 RCD autotest results

7. Ramp test measurement with the following measurement parameters:

- Test current started with the positive half-wave at 0° .

This measurement determine the minimum current required to trip the RCD. After the measurement has been started, the test current generated by the instrument is continuously increased, until the RCD trips. The following menu is displayed:

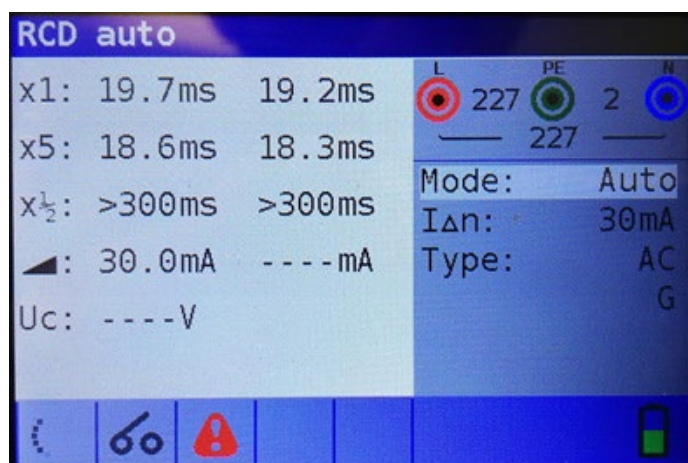

Figure 5-26: Step 7 RCD autotest results

8. Ramp test measurement with the following measurement parameters:

- Test current started with the negative half-wave at 180°.

This measurement determine the minimum current required to trip the RCD. After the measurement has been started, the test current generated by the instrument is continuously increased, until the RCD trips. The following menu is displayed:



Figure 5-27: Step 8 RCD autotest results

Displayed results:

- x1 (left).....Step 1 trip-out time result, t3 (I Δ N, 0°),
- x1 (right).....Step 2 trip-out time result, t4 (I Δ N, 180°),
- x5 (left).....Step 3 trip-out time result, t5 (5× I Δ N, 0°),
- x5 (right).....Step 4 trip-out time result, t6 (5× I Δ N, 180°),
- x $\frac{1}{2}$ (left).....Step 5 trip-out time result, t1 ($\frac{1}{2}$ ×I Δ N, 0°),
- x $\frac{1}{2}$ (right).....Step 6 trip-out time result, t2 ($\frac{1}{2}$ ×I Δ N, 180°),
- I Δ (+).....Step 7 trip-out current ((+) positive polarity)
- I Δ (-).....Step 8 trip-out current ((-) negative polarity)
- UcContact voltage for rated I Δ N.

Note:

- ❑ the **x1** Auto tests will be automatically skipped for RCD type B with rated residual currents of $I_{\Delta N} = 1000\text{ mA}$
- ❑ the **x5** Auto tests will be automatically skipped in the following cases:
 RCD type AC with rated residual currents of $I_{\Delta N} = 1000\text{ mA}$
 RCD type A and B with rated residual currents of $I_{\Delta N} \geq 300\text{ mA}$
- ❑ In these cases, the auto test result passes if the t1 to t4 results pass, and on the display are omitted t5 and t6.

5.3.10 WARNINGS

- ❑ Leakage currents in the circuit following the residual current device (RCD) may influence the measurements.
- ❑ Special conditions in residual current devices (RCD) of a particular design, for example of type S (selective and resistant to impulse currents) shall be taken into consideration.
- ❑ equipment in the circuit following the residual current device (RCD) may cause a considerable extension of the operating time. Examples of such equipment might be connected capacitors or running motors.

5.4 Fault loop impedance and prospective fault current

The loop impedance function has three sub-functions available:

LOOP IMPEDANCE sub-function performs a fast fault loop impedance measurement on supply systems which do not contain RCD protection.

LOOP IMPEDANCE RCD trip-lock sub-function performs fault loop impedance measurement on supply systems which are protected by RCDs

LOOP IMPEDANCE Rs sub-function with configurable RCD-value performs fault loop impedance measurement on supply systems which are protected by RCDs

5.4.1 Fault loop impedance

The fault loop impedance measures the impedance of the fault loop in the event that a short-circuit to an exposed conductive part occurs (i.e. a conductive connection occurs between the phase conductor and protective earth conductor). In order to measure loop impedance, the instrument uses a high-test current.

Prospective fault current (IPFC) is calculated on the basis of the measured resistance as follows:

$$I_{PFC} = \frac{U_N \times \text{scaling factor}}{Z_{L-PE}}$$

Where:

Nominal input voltage U_N	Voltage range
115V	$(93\text{ V} \leq U_{L-PE} < 134\text{ V})$
230V	$(185\text{ V} \leq U_{L-PE} \leq 266\text{ V})$

How to perform fault loop impedance measurement

Step 1 Select the **LOOP** function with the function selector switch and select the **LOOP** mode with the ▲▼ and ◀▶ navigation keys. Then select desired **Type** (select various types or custom or off), **Time** and **Curr** option values with the ▲▼ and ◀▶ navigation keys. The following menu is displayed:

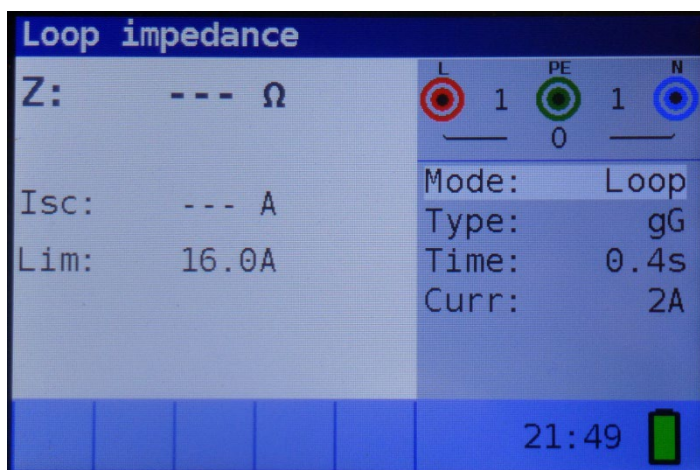

Figure 5-28: Loop impedance measurement menu

Step 2 Connect the test leads to the instrument and follow the connection diagram shown in the figure 5.29 to perform fault loop impedance measurement.

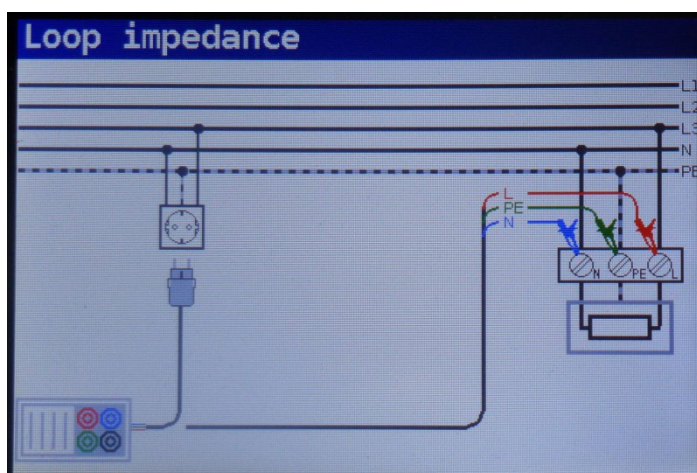

Figure 5-29: Connection of plug cable and universal test cable

Step 3 Check for any warnings displayed on the screen and check the online voltage/terminal monitor before starting the measurement. If everything is ok and the ► is shown, press the TEST key. After performing the measurement, the test results will appear on the display.

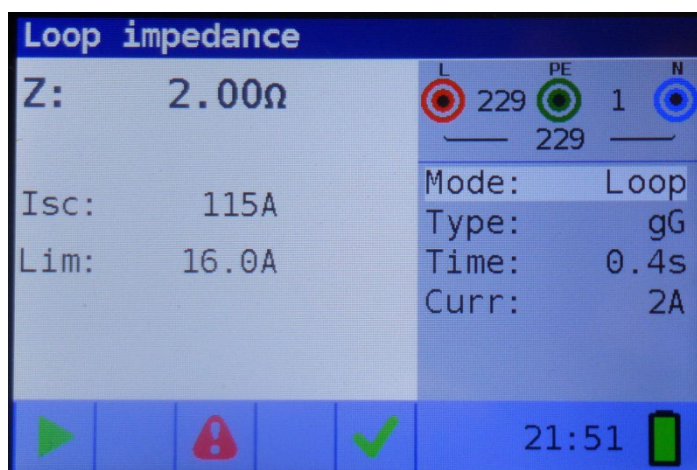

Figure 5-30: Example of loop impedance measurement results

Displayed results:

Z.....Fault loop impedance,

Isc.....Prospective fault current (displayed in amps),

Notes:

- ❑ The specified accuracy of test parameters is valid only if mains voltage is stable during the measurement.
- ❑ The Fault loop impedance measurement trips RCD protected circuits.

5.4.2 The fault loop impedance test RCD (for RCD protected circuits)

The fault loop impedance is measured with a low test current to avoid tripping the RCD. This function can also be used for fault loop impedance measurement in system equipped with RCDs which have a rated trip-out current of 30 mA and above.

Prospective fault current (IPFC) is calculated on basis of measured resistance as follows:

$$I_{PFC} = \frac{U_N \times \text{scaling factor}}{Z_{L-PE}}$$

Where:

Nominal input voltage U_N	Voltage range
115V	(93 V ≤ U_{L-PE} < 134 V)
230V	(185 V ≤ U_{L-PE} ≤ 266 V)

How to perform RCD trip-lock measurement

Step 1 Select the **LOOP** function with the function selector switch and select the **RCD** mode with the ▲▼ and ◀▶ navigation keys. Then select desired **Type** (select various types or custom or off), **Time** and **Curr** option values with the ▲▼ and ◀▶ navigation keys. The following menu is displayed:

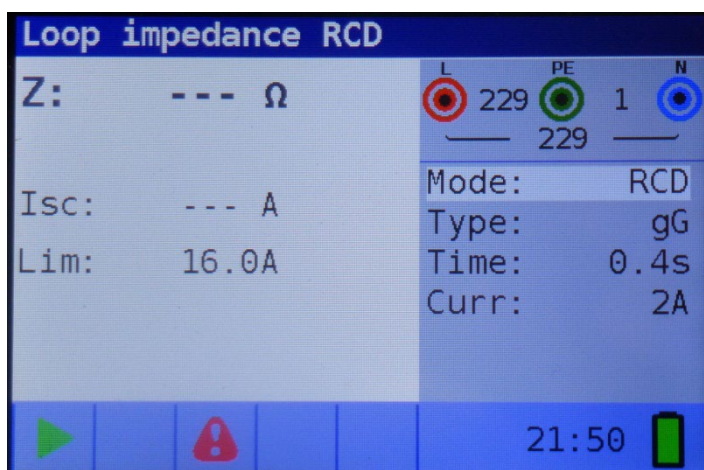

Figure 5-31: Trip-lock function menu

Step 2 Connect the appropriate test leads to the instrument and follow the connection diagram shown in figure 5.13 to perform RCD trip-lock measurement (see chapter 5.3.6 *Contact voltage*).

Step 3 Check for warnings on the display and check the online voltage/terminal monitor before starting the measurement. If everything is ok and the ► is shown, press the TEST key. After performing the measurement, the results will appear on the display.

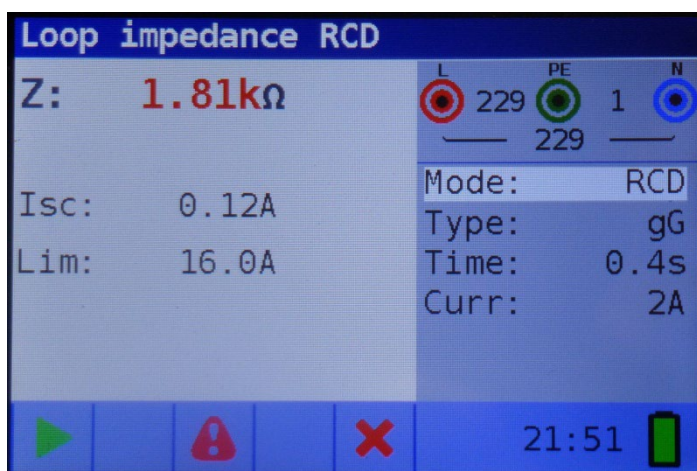

Figure 5-32: Example of fault loop impedance measurement results using RCD function

Displayed result:

Z.....Fault loop impedance,
Isc.....Prospective fault current,

Notes:

- ❑ The measurement of fault loop impedance using trip-lock function does not normally trip an RCD. However, if the trip limit may be exceeded as a result of leakage current flowing through the PE protective conductor or a capacitive connection between L and PE conductors.
- ❑ The specified accuracy of test parameter is valid only if mains voltage is stable during the measurement.

5.4.3 The fault loop impedance test Rs (for adjustable current)

The fault loop impedance is measured with a low test current to avoid tripping the RCD. It is possible to adjust the value of the RCD, while the test current depends on the chosen value. By this function it is possible to test each RCD-type with the maximum possible current without tripping the RCD.

Prospective fault current (IPFC) is calculated on basis of measured resistance as follows:

$$I_{PFC} = \frac{U_N \times \text{scaling factor}}{Z_{L-PE}}$$

Where:

Nominal input voltage U_N	Voltage range
115V	$(93 \text{ V} \leq U_{L-PE} < 134 \text{ V})$
230V	$(185 \text{ V} \leq U_{L-PE} \leq 266 \text{ V})$

How to perform Rs trip-lock measurement

Step 1 Select the **LOOP** function with the function selector switch and select the **Rs** mode with the ▲▼ and ◀▶ navigation keys. Then select desired **Type** (select various types or custom or off), **current**, **Limit** and **scaling factor** option values with the ▲▼ and ◀▶ navigation keys. The following menu is displayed:

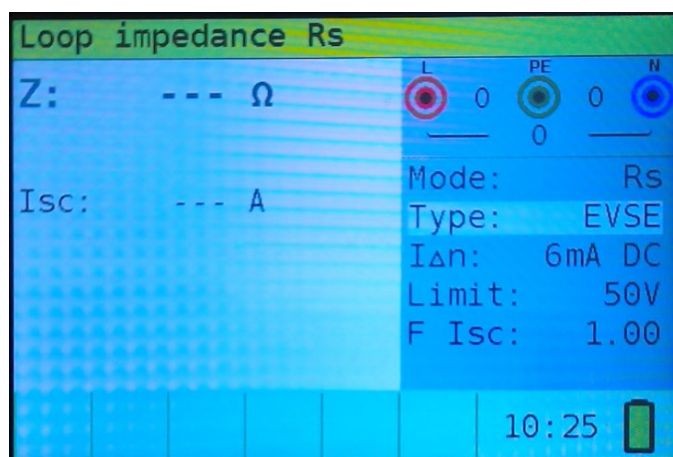



Figure 5-33: Loop impedance Rs function menu

- Step 2** Connect the appropriate test leads to the instrument and follow the connection diagram shown in figure 5.13 to perform RCD trip-lock measurement (see chapter 5.3.6 *Contact voltage*).
- Step 3** Check for warnings on the display and check the online voltage/terminal monitor before starting the measurement. If everything is ok and the  is shown, press the TEST key. After performing the measurement, the results will appear on the display.

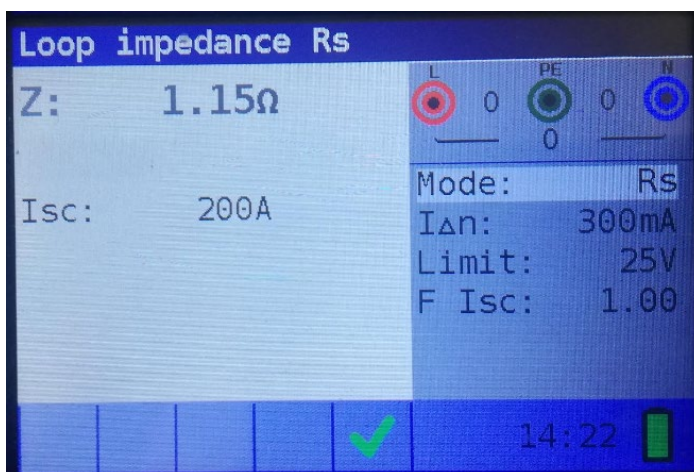

Figure 5-34: Example of fault loop impedance measurement results using Rs function

Displayed result:

Z.....Fault loop impedance,
Isc.....Prospective fault current,

Notes:

- ❑ The measurement of fault loop impedance using trip-lock function does not normally trip an RCD. However, if the trip limit may be exceeded as a result of leakage current flowing through the PE protective conductor or a capacitive connection between L and PE conductors.
- ❑ The specified accuracy of test parameter is valid only if mains voltage is stable during the measurement.

5.5 Line impedance and prospective short-circuit current

The line impedance is a measurement of the impedance of the current loop when a short-circuit to the neutral conductor occurs (conductive connection between phase conductor and neutral conductor in single-phase system or between two phase conductors in three-phase system). A high test current is used to perform the line impedance measurement.

Prospective short circuit current is calculated as follows:

$$I_{PFC} = \frac{U_N \times \text{scaling factor}}{Z_{L-N(L)}}$$

Where:

Nominal input voltage U_N	Voltage range
115V	(93 V ≤ U_{L-PE} < 134 V)
230V	(185 V ≤ U_{L-PE} ≤ 266 V)
400V	(321V ≤ U_{L-PE} ≤ 485 V)

How to perform line impedance measurement

Step 1 Select the **LINE IMPEDANCE** function with the function selector switch. Then select desired **Type** (select various types or custom or off), **Time** and **Curr** option values with the ▲▼ and ◀▶ navigation keys. The following menu is displayed:

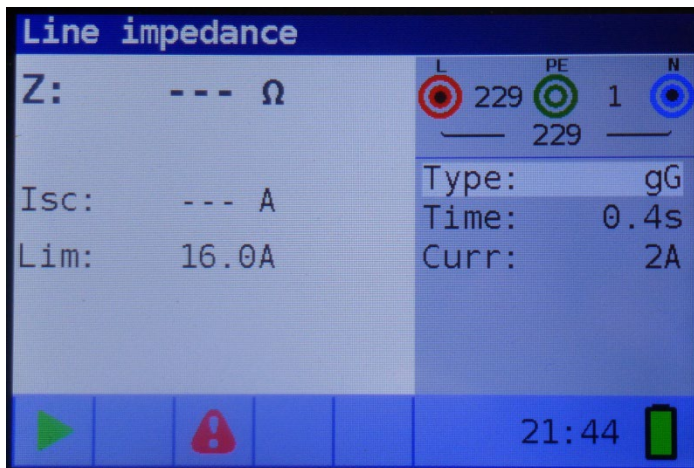

Figure 5-35: Line impedance measurement menu

Step 2 Connect the appropriate test leads to the instrument and follow the connection diagram shown in figure 5.36 to perform phase-neutral or phase-phase line impedance measurement.

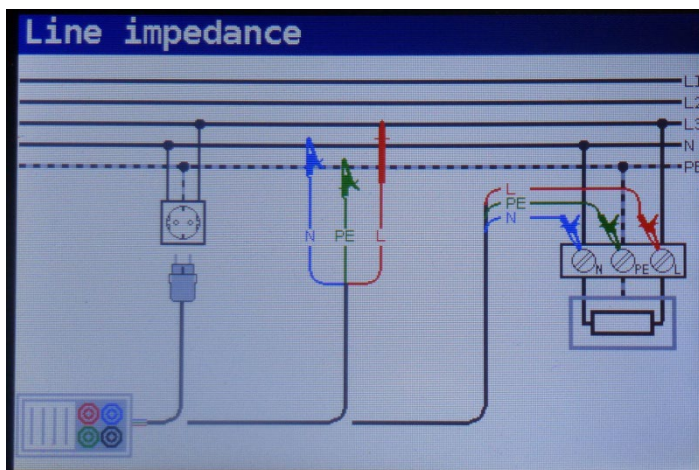

Figure 5-356: Line impedance measurement

Step 3 Check for warnings displayed on the screen and check the online voltage/terminal monitor before starting the measurement. If everything is ok and the ► is shown, press the TEST key. After performing the measurement, the results will appear on the display.



Figure 5-37: Example of line impedance measurement results

Displayed results:

Z.....Line impedance,
Isc.....Prospective short-circuit current,

Notes:

- The specified accuracy of the test parameter is valid only if mains voltage is stable during the measurement.

5.5.1 Voltage drop test

The voltage drop function is a measurement of the line impedance (see chapter 5.5) and result is compared to a reference result which has been taken before on some other point of the installation (usually the entry point since this point has the lowest impedance). The voltage drop in %, the impedance and the prospective short circuit current are shown.

The voltage drop in % is calculated as follows:

$$\Delta U = \frac{(Z - Z_{REF}) \times I_N}{U_N}$$

How to perform voltage drop measurement

- Step 1** Select the **LINE IMPEDANCE** function with the function selector switch and select Voltage drop with the ▲▼ and ◀▶ navigation keys. Then select desired **Type** (select various types or custom or off), **Time** and **Curr** option values with the ▲▼ and ◀▶ navigation keys. The following menu is displayed:

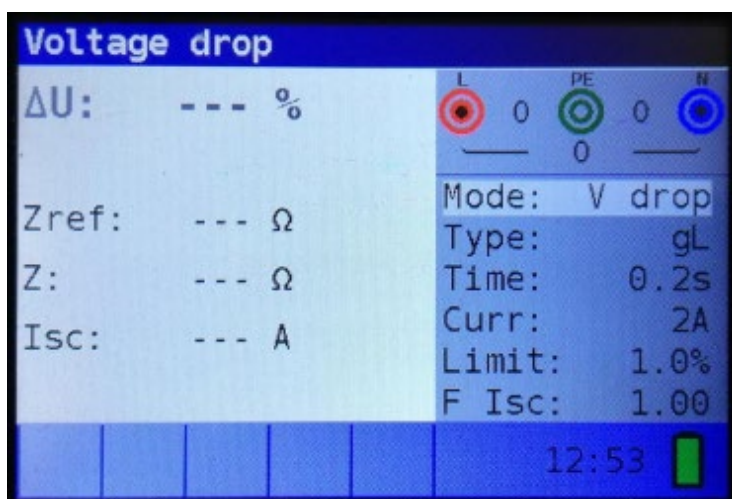

Figure 5-38: Voltage drop measurement menu

- Step 2** Connect the appropriate test leads from the reference point to the instrument and follow the connection diagram shown in figure 5.36 to perform phase-neutral or phase- phase line impedance measurement.
- Step 3** Press COM key and 'REF' will be shown in display. The device is then ready to take the measurement of the reference position in the installation. Check for warnings displayed on the screen and check the online voltage/terminal monitor before starting the measurement. If everything is ok and the ► is shown, press the TEST key. After performing the measurement, the result for Zref will appear on the display.
- Step 4** Connect the appropriate test leads from the tested point to the instrument and follow the connection diagram shown in figure 5.36 to perform phase-neutral or phase- phase line impedance measurement. Check for warnings displayed on the screen and check the online voltage/terminal monitor before starting the measurement. If everything is ok and the ► is shown, press the TEST key. After performing the measurement, the results will appear on the display.

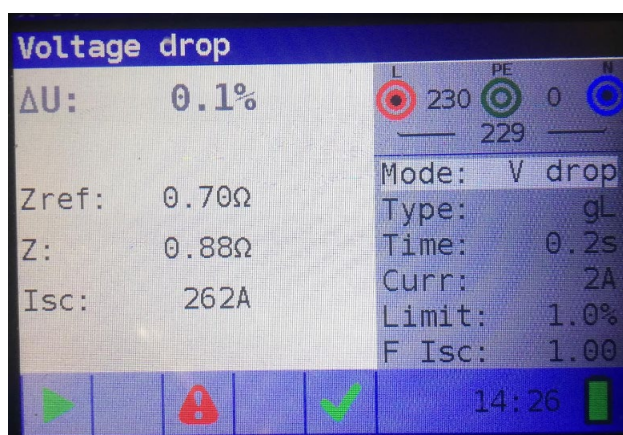

Figure 5-39: Example of voltage drop measurement results

Displayed results:

ΔUvoltage drop of the test point compared to the reference point

ZrefLine impedance of the reference point

Z.....Line impedance of the test point

I_{sc}.....Prospective short-circuit current of the test point

Notes:

- The specified accuracy of the test parameter is valid only if mains voltage is stable during the measurement.

5.6 Phase sequence testing

In practice, we often deal with the connection of three-phase loads (motors and other electro-mechanical machines) to three-phase mains installation. Some loads (ventilators, conveyors, motors, electro-mechanical machines, etc.) require a specific phase rotation and some may even be damaged if the rotation is reversed. This is why it is advisable to test phase rotation before connection is made.

How to test the phase sequence

- Step 1** Select the **VOLTAGE** function with the function selector switch. The following menu is displayed:

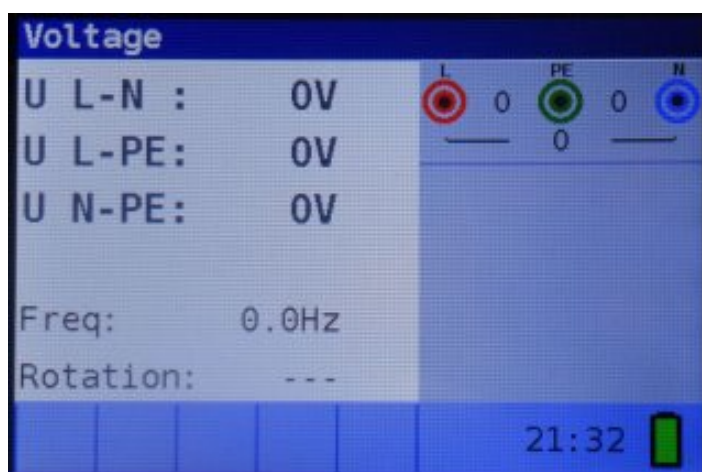

Figure 5-40: Phase rotation test menu

- Step 2** Connect test cable to the VOLTCRAFT IST instrument and follow the connection diagram shown in figure 5.41 to test phase sequence.

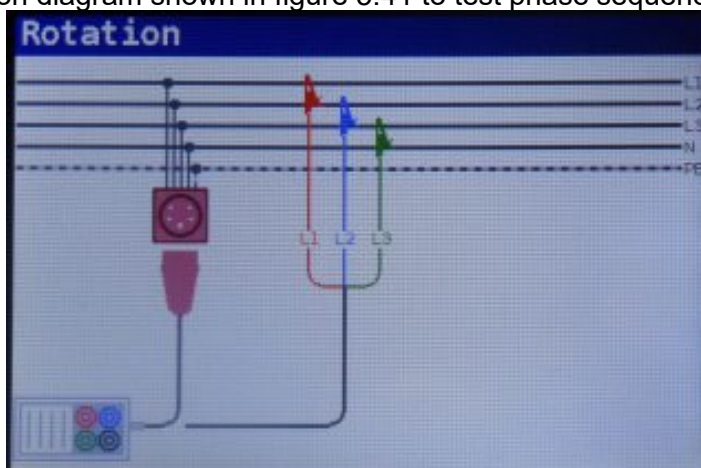

Figure 5-41: Connection of universal test cable and optional three phase cable

- Step 3** Check for warnings on the display and check the online voltage/terminal monitor. The phase sequence test is a continuously running test hence the results will be displayed as soon as the full test lead connection to the item under test has been made. All three-phase voltages are displayed in order of their sequence represented by the numbers 1, 2 and 3.

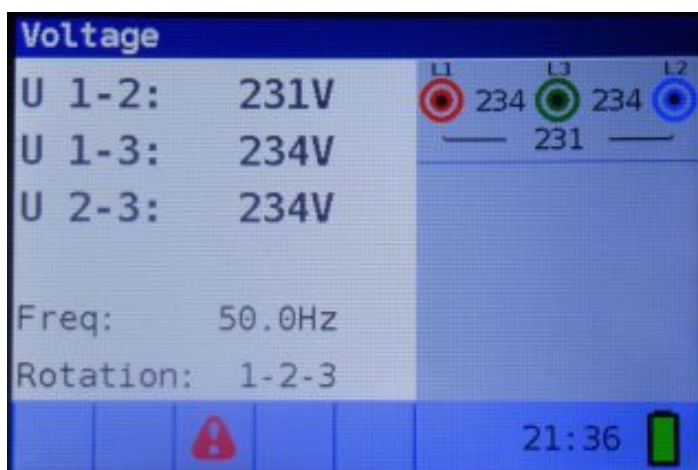

Figure 5-42: Example of phase sequence test result

Displayed results:

Freq.....Frequency,
Rotation Phase sequence,
 -.-.....Irregular rotation value.

5.7 Voltage and frequency

Voltage measurements should be carried out regularly while dealing with electric installations (carrying out different measurements and tests, looking for fault locations, etc.). Frequency is measured for example when establishing the source of mains voltage (power transformer or individual generator).

How to perform voltage and frequency measurement

Step 1 Select the **VOLTAGE** function with the function selector switch. The following menu is displayed:

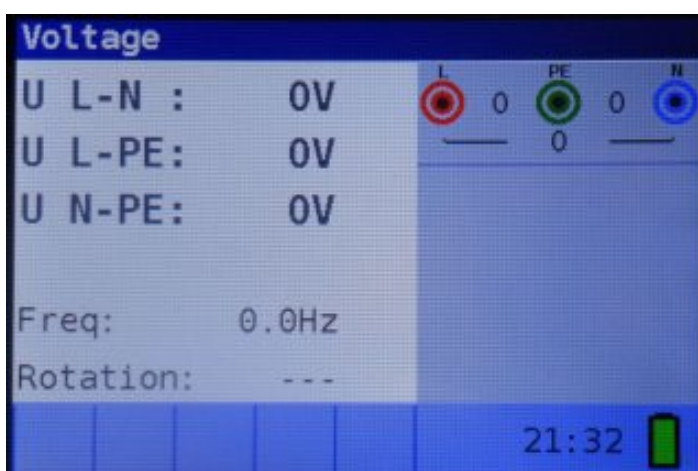

Figure 5-43: Voltage and frequency measurement menu

Step 2 Connect test cable to the VOLTCRAFT IST instrument and follow the connection diagram shown in figure 5.44 to perform a voltage and frequency measurement.

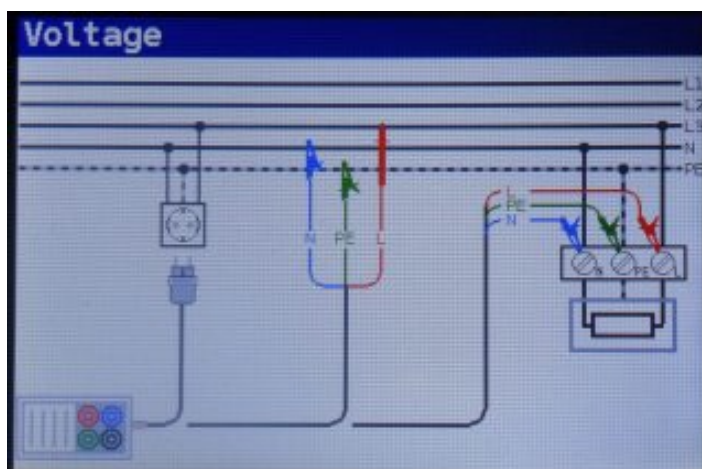

Figure 5-44: Connection diagram

Step 3 Check the displayed warnings. The Voltage and Frequency test continually runs, showing fluctuations as they occur, these results are shown on the display during measurement.

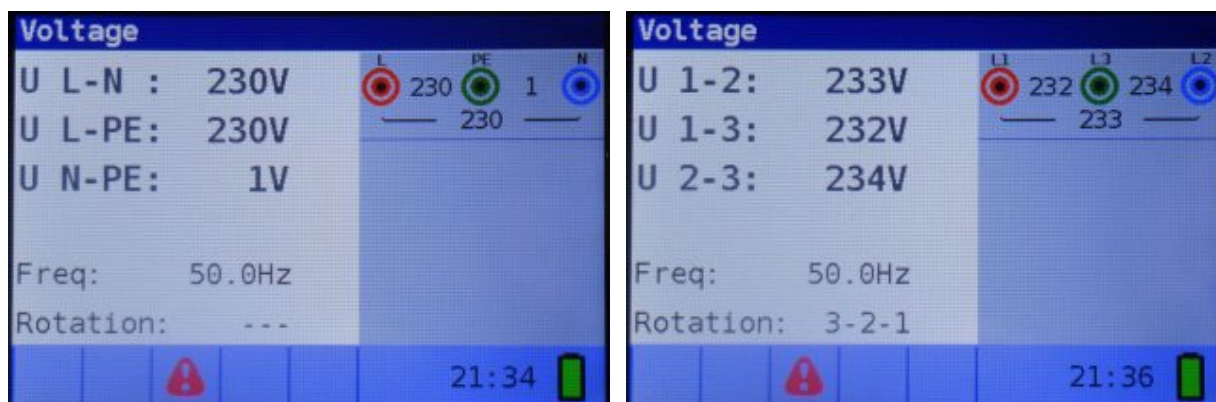

Figure 5-45: Examples of voltage and frequency measurements

Displayed results:

- U L-N** Voltage between phase and neutral conductors,
- U L-PE** Voltage between phase and protective conductors,
- U N-PE** Voltage between neutral and protective conductors.

When testing three-phase system the following results are displayed:

- U 1-2** Voltage between phases L1 and L2,
- U 1-3** Voltage between phases L1 and L3,
- U 2-3** Voltage between phases L2 and L3,

5.8 Earth Resistance [Voltcraft IST 3000 only]

5.8.1. Earth Resistance (Re) - 3-wire, 4wire

VOLTCRAFT IST 3000 allows resistance to earth measurement using 3-wire and 4wire measuring method.

How to perform Earth Resistance measurement

Step 1 Select the **Earth Resistance** function with the function selector switch and select the **Re** mode with the ▲▼ and ◀▶ navigation keys. The following menu will be displayed:

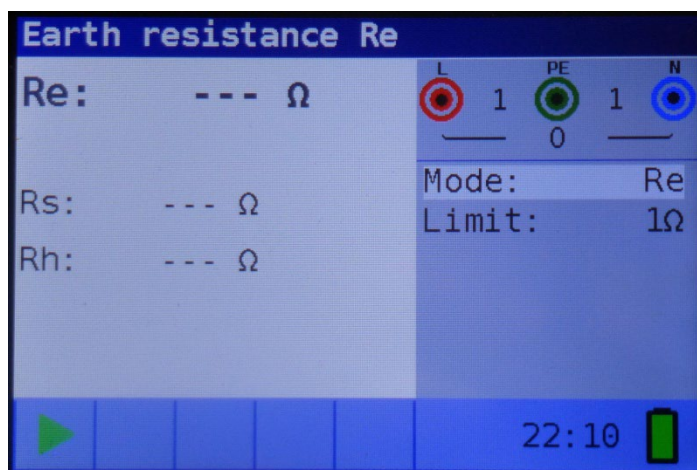

Figure 5-46: Earth Resistance (Re) measurement menu

Step 2 Set the following limit value:

- **Limit:** limit resistance value using the ▲▼ and ◀▶ navigation keys.

Step 3 Follow the connection diagram shown in figures 5.47 to perform the **Earth Resistance** measurement with 4 wires.

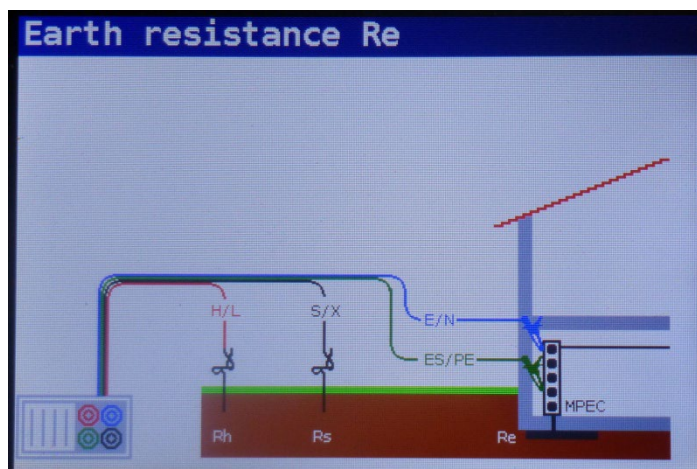

Figure 5-47: 4 wire connection diagram

Follow the connection diagram shown in figures 5.48 to perform the **Earth Resistance** measurement with 3 wires (ES connected to E).

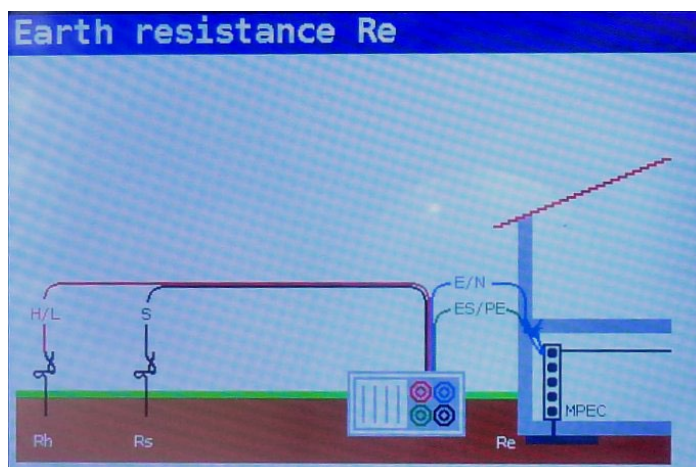

Figure 5-48: 3 wire connection diagram

Step 4 Check for any warnings and the online voltage/terminal monitor on the display before starting the measurement. If everything is ok and the ► is shown, press the TEST key. After performing the measurement, the results appear on the display together with the ✓ or ✗ indication (if applicable).

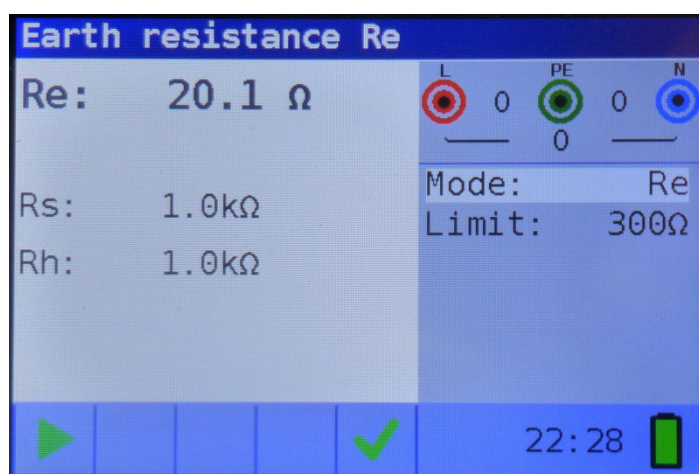

Figure 5-49: Example of resistance to earth measurement results

Displayed result:

Re.....resistance to earth.

Rs..... Resistance of S (potential) probe

Rh..... Resistance of H (current) probe

Notes:

- If a voltage of higher than 10 V exists between test terminals, the Earth Resistance measurement will not be performed.

5.8.2. Specific earth resistance (Ro)

It is advisable to measure Earth Resistivity, when defining parameters of earthing system (required length and surface of earth electrodes, most appropriate depth of installing earthing system etc.) in order to reach more accurate calculations.

How to perform Specific Earth Resistance measurement

Step 1 Select the **Earth Resistance** function with the function selector switch and select the **Ro** mode with the ▲▼ and ◀▶ navigation keys. The following menu will be displayed:

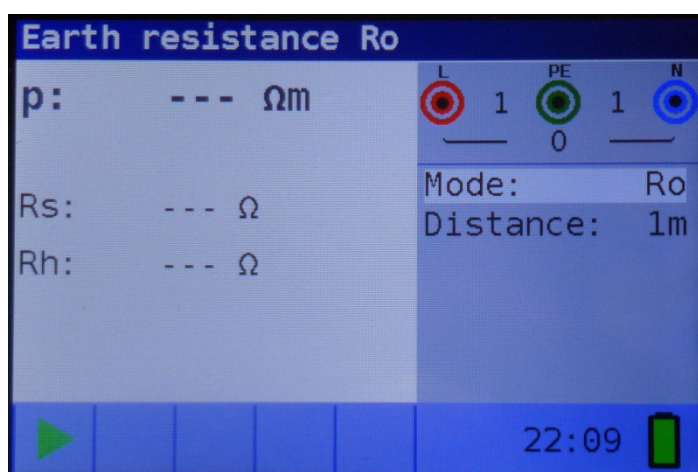

Figure 5-50: Specific Earth Resistance (Ro) measurement menu

Step 2 Set the following limit value:

- **Distance:** set distance “a” between test rods using the ▲▼ and ◀▶ navigation keys.

Step 3 Follow the connection diagram shown in figures 5.51 to perform the **Specific Earth Resistance** measurement.

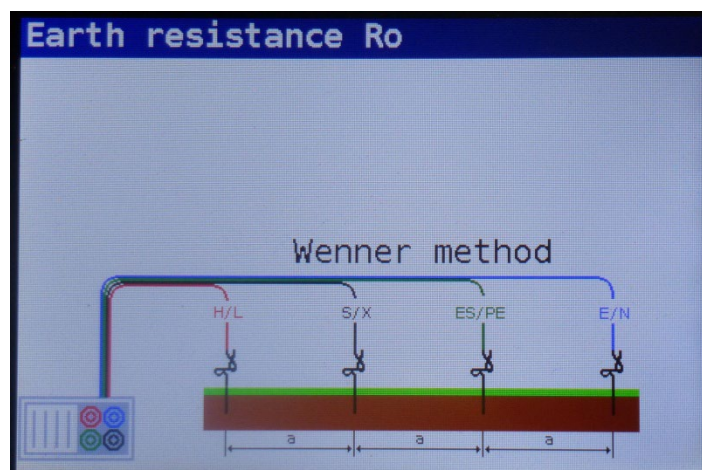





Figure 5-51: Connection diagram

- Step 4** Check for any warnings and the online voltage/terminal monitor on the display before starting the measurement. If everything is ok and the  is shown, press the TEST key.
After performing the measurement, the results appear on the display together with the  or  indication (if applicable).

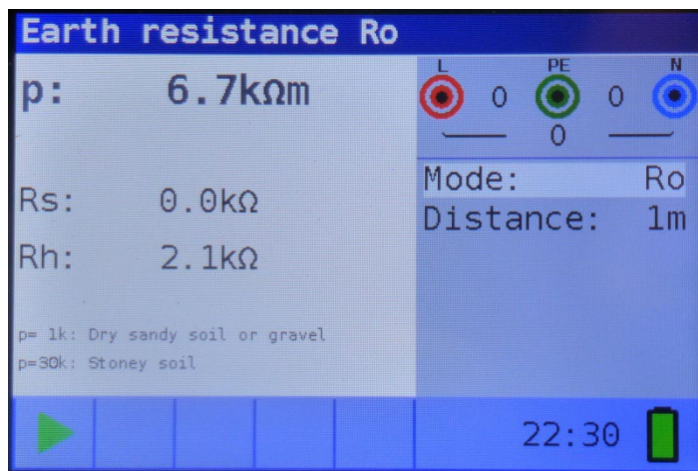

Figure 5-52: Example of specific earth resistance measurement results

Displayed result:

- Ro**..... specific earth resistance.
- Rs**..... Resistance of S (potential) probe
- Rh**..... Resistance of H (current) probe

Notes:

- If a voltage of higher than 10 V exists between test terminals, the Earth Resistance measurement will not be performed.

6 Maintenance

6.1. Replacing fuses

There are three fuses under back battery cover of the VOLTCRAFT IST instrument.

- F3

M 0.315 A / 250 V, 20×5 mm

This fuse protects internal circuitry of low-value resistance function if test probes are connected to the mains supply voltage by mistake.

- F1, F2

F 4 A / 500 V, 32×6.3 mm

General input protection fuses for the L/L1 and N/L2 test terminals.

Warnings:

-  Disconnect any measuring accessory from the instrument and ensure that the instrument is turned off before opening the battery/fuse compartment cover, hazardous voltage can exist inside this compartment!
 - Replace any blown fuses with exactly the same type of fuse. The instrument can be damaged and/or operator's safety impaired if this is not performed!

The Position of fuses can be seen in figure 3.4 in chapter 3.3 Back panel.

6.2. Cleaning

No special maintenance is required for the housing. To clean the surface of the instrument use a soft cloth slightly moistened with soapy water or alcohol. Then leave the instrument to dry totally before use.

Warnings:

- Do not use liquids based on petrol or hydrocarbons!
- Do not spill cleaning liquid over the instrument!

6.3. Periodic calibration

It is essential that the test instrument is regularly calibrated in order for the technical specification listed in this manual to be guaranteed. We recommend an annual calibration. The calibration should be done by an authorized technical person only. Please contact your dealer for further information.

6.4. Service

For repairs under warranty, or at any other time, please contact your distributor. Unauthorized person(s) are not allowed to open the VOLTCRAFT IST instrument. There are no user replaceable components inside the instrument, except for the three fuses inside the battery compartment, refer to chapter 6.1 *Replacing fuses*.

6.5. Batteries

- **Prevent Memory Effect**
Discharge and recharge the nickel-metal hydride battery's full once in a while. This helps to keep the battery healthy by avoiding crystal development in discharged areas.
- **Exercise the Battery**
Do not leave the battery unused for a longer period. This allows crystals to develop, which reduces the battery's ability to hold a charge. A new battery break procedure should be applied to a dormant battery to regain its ability to work properly.
- **New Battery Break-in**
New batteries must be fully charged before use since they are bought in discharged conditions. It is essential to charge and discharge the battery completely so that it can regain its maximum rated capacity.

7 Technical specifications

7.1 Insulation resistance

Insulation resistance (nominal voltages 50V_{DC})

Measurement range according to 61557 from 50kΩ-80MΩ

Measuring range (MΩ)	Resolution (MΩ)	Accuracy
0.1 – 80.0	(0.100 ... 1.999) 0.001	±(5 % of reading + 3 digits)
	(2.00 ... 80.00) 0.01	

Insulation resistance (nominal voltages 100 V_{DC} and 250 V_{DC})

Measurement range according to 61557 from 100kΩ-199.9MΩ

Measuring range (MΩ)	Resolution (MΩ)	Accuracy
0.1 – 199.9	(0.100 ... 1.999) 0.001	±(5 % of reading + 3 digits)
	(2.00 ... 99.99) 0.01	
	(100.0 ... 199.9) 0.1	

Insulation resistance (nominal voltages 500 V_{DC} and 1000 V_{DC})

Measurement range according to 61557 from 500kΩ-199.9MΩ

Measuring range (MΩ)	Resolution (MΩ)	Accuracy
0.1 – 199.9	(0.100 ... 1.999) 0.001	±(2 % of reading + 3 digits)
	(2.00 ... 99.99) 0.01	
	(100.0 ... 199.9) 0.1	
200 – 999	(200 ... 999) 1	±(10 % of reading)

Voltage

Measuring range (V)	Resolution (V)	Accuracy
0 – 1200	1	±(3 % of reading + 3 digits)

Nominal voltages..... 50V_{DC}, 100 V_{DC}, 250 V_{DC}, 500 V_{DC}, 1000 V_{DC}

Open circuit voltage..... -0 % / +20 % of nominal voltage

Measuring current min. 1 mA at R_N=U_N×1 kΩ/V

Short circuit current max. 15 mA

The number of possible tests

with a new set of batteries up to 1000 (with 2300mAh battery cells)

Auto discharge after test.

In case the instrument gets moistened the results could be impaired. In such case it is recommended to dry the instrument and accessories for at least 24 hours.

7.2 Continuity resistance

7.2.1 Low R (depends on model)

Measuring range according to EN61557-4 is 0.1 Ω – 1999 Ω.

Measuring range (Ω)	Resolution (Ω)	Accuracy
0.1 – 20.0	(0.10 Ω ... 19.99 Ω) 0.01 Ω	±(3 % of reading + 3 digits)
	(20.0 Ω ... 99.9 Ω) 0.1 Ω	
20.0 – 1999	(100 Ω ... 1999 Ω) 1 Ω	±(5% of reading)
	(20.0 Ω ... 99.9 Ω) 0.1 Ω	

Open-circuit voltage 5 V_{DC}
 Measuring current min. 200 mA into load resistance of 2 Ω
 Test lead compensation up to 5 Ω
 The number of possible tests
 with a new set of batteries up to 1400 (with 2300mAh battery cells)
 Automatic polarity reversal of the test voltage.

7.2.2 Low current continuity

Measuring range (Ω)	Resolution (Ω)	Accuracy
0.1 – 1999	(0.1 Ω ... 99.9 Ω) 0.1 Ω (100.0 Ω ... 1999 Ω) 1 Ω	±(5 % of reading + 3 digits)

Open-circuit voltage 5 V_{DC}
 Short-circuit current max. 7 mA
 Test lead compensation up to 5 Ω

7.3 RCD testing

7.3.1 General data

Nominal residual current 6mA (*), 10 mA, 30 mA, 100 mA, 300 mA, 500 mA, 650mA (*), 1000 mA (*)
 Nominal residual current accuracy.... -0 / +0.1·I_Δ; I_Δ = I_{ΔN}, 2×I_{ΔN}, 5×I_{ΔN}
 -0.1·I_Δ / +0; I_Δ = 1/2×I_{ΔN}
 Test current shape Sine-wave (AC), DC (B), pulsed (A) (*)
 RCD type..... general (G, non-delayed), selective (S, time-delayed), EVSE (*)
 Test current starting polarity 0° or 180°
 Voltage range 93V-134V; 185V-266V; 45Hz-65Hz
 (*) depends on model

RCD test current selection (r.m.s. value calculated to 20 ms) according to IEC 61009:

I _{ΔN} (mA)	1/2×I _{ΔN}			1×I _{ΔN}			2×I _{ΔN}			5×I _{ΔN}			RCD IΔ		
	AC	A	B	AC	A	B	AC	A	B	AC	A	B	A C	A	B
6 (*)	3	2,1	3	6	12	12	12	24	24	30	60	60	✓	✓	✓
10	5	3,5	5	10	20	20	20	40	40	50	100	100	✓	✓	✓
30	15	10,5	15	30	42	60	60	84	120	150	212	300	✓	✓	✓
100	50	35	50	100	141	200	200	282	400	500	707	1000	✓	✓	✓
300	150	105	150	300	424	600	600	848	na	1500	na	na	✓	✓	✓
500	250	175	250	500	707	1000	1000	1410	na	2500	na	na	✓	✓	✓
650 (*)	325	228	325	650	919	1300	1300	na	na	na	na	na	✓	✓	✓
1000 (*)	500	350	500	1000	1410	na	2000	na	na	na	na	na	✓	✓	✓

(na) not available / (*) depends on model)

7.3.2 Contact voltage

Measuring range according to EN61557-6 is 3.0 V – 49.0 V f. limit contact voltage 25 V.
 Measuring range according to EN61557-6 is 3.0 V – 99.0 V for limit contact voltage 50 V.

Measuring range (V)	Resolution (V)	Accuracy
3.0 – 9.9	0.1	(-0%/+10%) of reading + 5 digits
10.0 – 99.9	0.1	(-0%/+10%) of reading + 5 digits

Test current max. $0.5 \times I_{\Delta N}$
 Limit contact voltage 25 V, 50 V

Fault loop resistance at contact voltage is calculated as $R_L = \frac{U_c}{I_{\Delta N}}$

7.3.3 Trip-out time

Complete measurement range corresponds to EN61557-6 requirements. Specified accuracies are valid for complete operating range.

Measuring range (ms)	Resolution (ms)	Accuracy
0.0 – 500.0	0.1	±3 ms

Test current $\frac{1}{2} \times I_{\Delta N}$, $I_{\Delta N}$, $2 \times I_{\Delta N}$, $5 \times I_{\Delta N}$
 Multipliers not available see test current selection table

7.3.4 Trip-out current

Measurement range corresponds to EN61557-6 for $I_{\Delta N} \geq 10\text{mA}$. Specified accuracies are valid for complete operating range.

Measuring range I_{Δ}	Resolution I_{Δ}	Accuracy
$0.2 \times I_{\Delta N} - 1.1 \times I_{\Delta N}$ (AC type)	$0.05 \times I_{\Delta N}$	$\pm 0.1 \times I_{\Delta N}$
$0.2 \times I_{\Delta N} - 1.5 \times I_{\Delta N}$ (A type, $I_{\Delta N} \geq 30\text{ mA}$)	$0.05 \times I_{\Delta N}$	$\pm 0.1 \times I_{\Delta N}$
$0.2 \times I_{\Delta N} - 2.2 \times I_{\Delta N}$ (A type, $I_{\Delta N} = 10\text{ mA}$)	$0.05 \times I_{\Delta N}$	$\pm 0.1 \times I_{\Delta N}$
$0.2 \times I_{\Delta N} - 2.2 \times I_{\Delta N}$ (B type)	$0.05 \times I_{\Delta N}$	$\pm 0.1 \times I_{\Delta N}$

Trip-out time

Measuring range (ms)	Resolution (ms)	Accuracy
0 – 300	1	±3 ms

Contact voltage

Measuring range (V)	Resolution (V)	Accuracy
3.0 – 9.9	0.1	(-0%/+10%) of reading + 5 digits
10.0 – 99.9	0.1	(-0%/+10%) of reading + 5 digits

7.4 Fault loop impedance and prospective fault current

Zloop L-PE, I_{pfc} sub-function

Measuring range according to EN61557-3 is 0.25 Ω – 1999 Ω.

Measuring range (Ω)	Resolution (Ω) (*)	Accuracy
0.2 – 9999	(0.20 ... 19.99) 0.01 (20.0 ... 99.9)0.1 (100 ... 9999)1	±(5 % of reading + 5 digits)

(*) depends on model

Prospective fault current (calculated value)

Measuring range (A)	Resolution (A)	Accuracy
0.00 – 19.99	0.01	Consider accuracy of fault loop resistance measurement
20.0 – 99.9	0.1	
100 – 999	1	
1.00k – 9.99k	10	
10.0 – 100.0k	100	

Test current (at 230 V)..... 3.4 A, 50Hz Sine wave (10 ms ≤ t_{LOAD} ≤ 15 ms)

Nominal voltage range..... 93 V – 134 V; 185 V – 266 V (45 Hz – 65 Hz)

Zloop L-PE RCD and R_s, I_{pfc}, non trip subfunction

Measuring range according to EN61557 is 0.75 Ω – 1999 Ω.

Measuring range (Ω)	Resolution (Ω) (*)	Accuracy *)
0.4 – 19.99	(0.40 ... 19.99) 0.01	±(5 % of reading + 10 digits)
20.0 – 9999	(20.0 ... 99.9) 0.1 (100 ... 9999) 1	± 10 % of reading

(*) depends on model

*) Accuracy may be impaired in case of heavy noise on mains voltage.

Prospective fault current (calculated value)

Measuring range (A)	Resolution (A)	Accuracy
0.00 – 19.99	0.01	Consider accuracy of fault loop resistance measurement
20.0 – 99.9	0.1	
100 – 999	1	
1.00k – 9.99k	10	
10.0 – 100.0k	100	

No trip out of RCD.

Nominal voltage range..... 93 V – 134 V; 185 V – 266 V (45 Hz – 65 Hz)

7.5 Line impedance and prospective short-circuit current

Line impedance

Measuring range according to EN61557-3 is 0.25Ω – 1999Ω.

Z_{line} L-L, L-N, I_{psc} subfunction

Measuring range (Ω)	Resolution (Ω) (*)	Accuracy
0.2 – 9999	(0.20 ... 19.99) 0.01 (20.0 ... 99.9)0.1 (100 ... 9999)1	±(5 % of reading + 5 digits)

(*) depends on model

Prospective short-circuit current (calculated value)

Measuring range (A)	Resolution (A)	Accuracy
0.00 – 19.99	0.01	Consider accuracy of line resistance measurement
20.0 – 99.9	0.1	
100 – 999	1	
1.00k – 9.99k	10	
10.0 – 100.0	100	

Test current (at 230 V)..... 3.4 A, 50Hz Sine wave (10 ms ≤ t_{LOAD} ≤ 15 ms)

Nominal voltage range..... 93V – 134V; 185V – 266V; 321V – 485V (45Hz – 65Hz)

Voltage drop:

Measuring range (%)	Resolution (%)	Accuracy
0.0 – 9.9	0.1	Consider accuracy of the line measurement (only calculated value)

7.6 Phase rotation

Measuring according to EN61557-7

Nominal mains voltage range 50 V_{AC} – 550 V_{AC}

Nominal frequency range 45 Hz – 400 Hz

Result displayed Right:1-2-3 ; Left: 3-2-1

7.7 Voltage and frequency

Measuring range (V)	Resolution (V)	Accuracy
0 – 550	1	±(2 % of reading + 2 digits)

Frequency range 0 Hz, 45 Hz – 400 Hz

Measuring range (Hz)	Resolution (Hz)	Accuracy
10 – 499	0.1	± 0.2% + 1 digit

Nominal voltage range..... 10V – 550 V

7.8 Earth Resistance

Measuring range according to EN61557-5 is 100Ωm – 1999 Ω.

Re – Earth resistance, 3-wire, 4-wire

Measuring range (Ω)	Resolution (Ω)	Accuracy
1.0 – 9999	(1.00 ... 19.99)	±(5 % of reading + 5 digits)
	(20.0 ... 199.9)	
	(200.0 ... 9999)	

Max. auxiliary earth electrode resistance Rh.....100×RE or 50 kΩ (whichever is lower)

Max. probe resistance Rs100×RE or 50 kΩ (whichever is lower)

Rh and Rs values are indicative.

Additional probe resistance error at Rhmax or Rsmax...±(10 % of reading + 10 digits)

Additional error at 3 V voltage noise (50 Hz).....±(5 % of reading + 10 digits)

Open circuit voltage.....< 30 VAC

Short circuit current< 30 mA

Test voltage frequency126.9 Hz

Test voltage shapesine wave

Automatic measurement of auxiliary electrode resistance and probe resistance.

Ro - Specific earth resistance

Measuring range	Resolution (Ωm)	Accuracy
6.0 Ωm ... 99.9 Ωm	0.1 Ωm	± (5 % of reading + 5 digits)
100 Ωm ... 999 Ωm	1 Ωm	± (5 % of reading + 5 digits)
1.00 kΩm ... 9.99 kΩm	0.01 kΩm	±(10% of read.)for Re 2kΩ...19.99kΩ
10.0 kΩm ... 99.9 kΩm	0.1 kΩm	±(10% of read.)for Re 2kΩ...19.99kΩ
100 kΩm ... 9999 kΩm	1 kΩm	±(20% of read.) for Re > 20 kΩ

Principle: $\rho = 2 \cdot \pi \cdot d \cdot R_e$, where R_e is a measured resistance in 4-wire method and d is distance between the probes.

Rh and Rs values are indicative.

7.9 General data

Power supply voltage 9 V_{DC} (6×1.5 V battery cells, size AA)
Power supply adapter..... 12 V DC / 1000 mA
Battery charging current < 600 mA (internally regulated)
Voltage of charged batteries 9 V_{DC} (6×1.5 V, at fully charged state)
Charging duration time typical 6 h
Operation typical 15 h

Overvoltage category CAT III / 600 V; CAT IV / 300 V

Protection classification double insulation
Pollution degree 2
Protection degree IP 42

Display 480X320 TFT LCD

COM-Port.....USB

Dimensions (w × h × d)..... 25 cm × 10.7 cm × 13.5 cm
Weight (without battery)..... 1.30 kg

Reference conditions

Reference temperature range 10 to 30 °C
Reference humidity range 40 – 70 %RH

Operating conditions

Working temperature range 0 – 40 °C
Maximum relative humidity..... 95 % RH (0 to 40 °C), non-condensing

Storage conditions

Temperature range -10 to +70 °C
Maximum relative humidity..... 90 % RH (-10 to +40 °C)
80 % RH (40 to 60 °C)

The error in operating conditions could be at most the error for reference conditions (specified in the manual for each function) + 1 % of measured value + 1 digit unless otherwise specified.

8 Storing measurements [Voltcraft IST 3000 only]

After the measurement is completed, results can be stored in internal memory of the instrument together with the sub-results and function parameters.

8.1. Overview

- VOLTcraft IST 3000 instrument can store up to 1000 measurements
- the list of records can be stepped through
- a single record or all records can be deleted
- the IDs for customer, location and object can be edited

If there is no actual measurement made and the **MEM** key is pressed and there are no records stored, an empty memory screen is displayed (Figure 8.2).

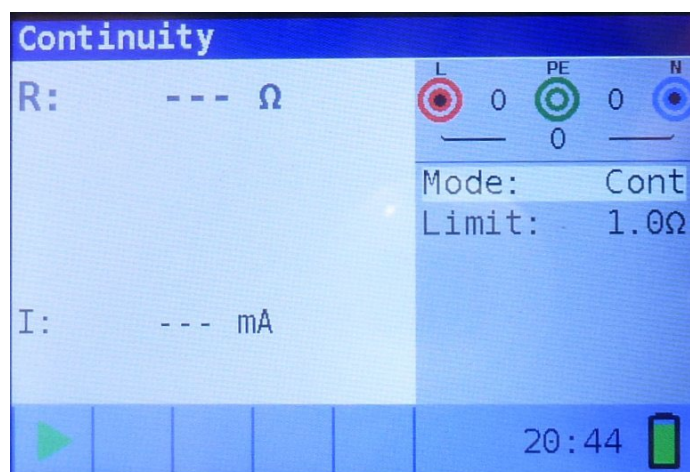

Figure 8.1: no result

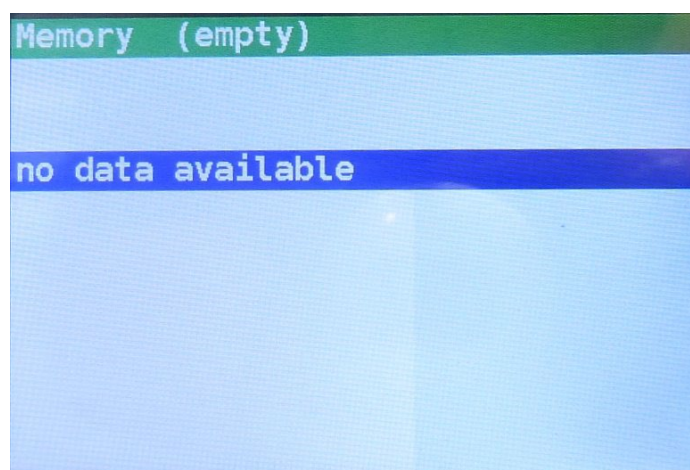

Figure 8.2: empty memory

8.2. Saving results

Step 1 When the measurement is finished (Figure 8.3) results are displayed on the screen.

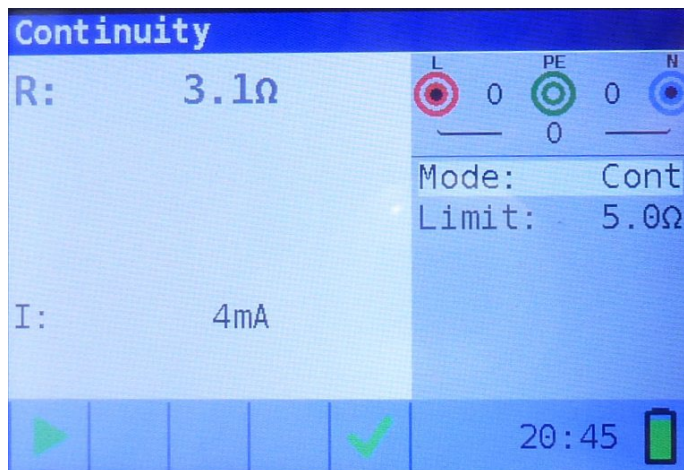

Figure 8.3: Last results

Step 2 Press the **MEM** key. The following is displayed (Figure 8.4):

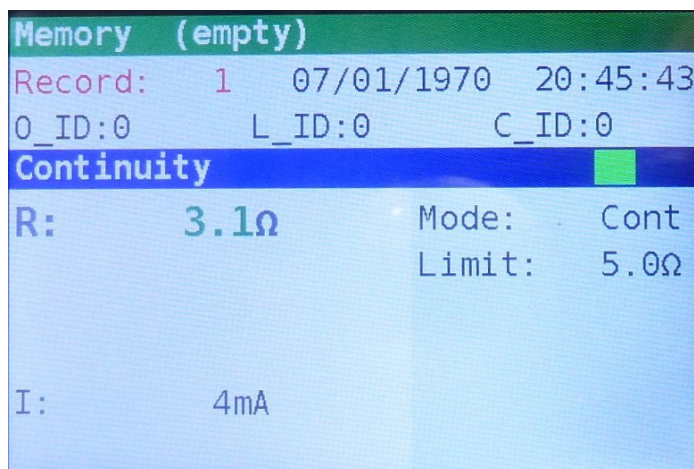

Figure 8.4: Save results

- Next record number in red letters
- Current date (day/month/year)
- Time (hour:minutes:seconds)
- Object ID
- Location ID
- Customer ID
- Measurement function
- Measurement Results
- Measurement Mode
- Measurement Limit

Step 3 To change customer ID, location ID or object ID, press the **LEFT** key. The following screen will be displayed (Figure 8.5).

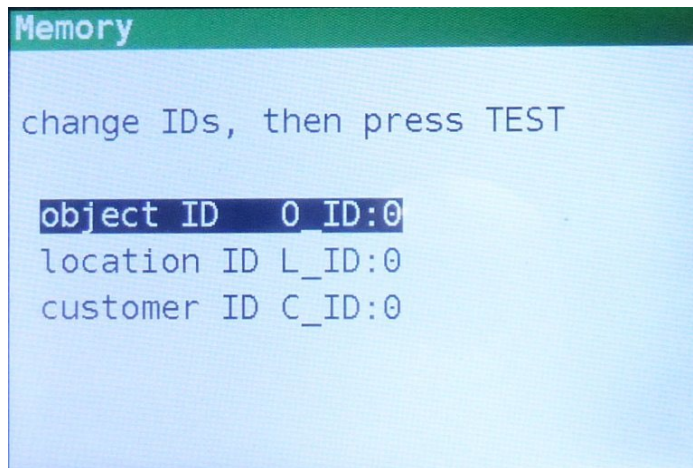

Figure 8.5: ID editor

Use the ▲ ▼ navigation keys to choose the ID type and the ◀ ▶ navigation keys to change the value of the ID.

Press the **Exit/Back/Return** key to return to the record screen without changing the IDs.

Press **TEST** to save the IDs in the actual record. These IDs will also be used for the following new records.

Step 4 To store the result of last measurement, press **TEST** key. The following will be displayed (Figure 8.6).

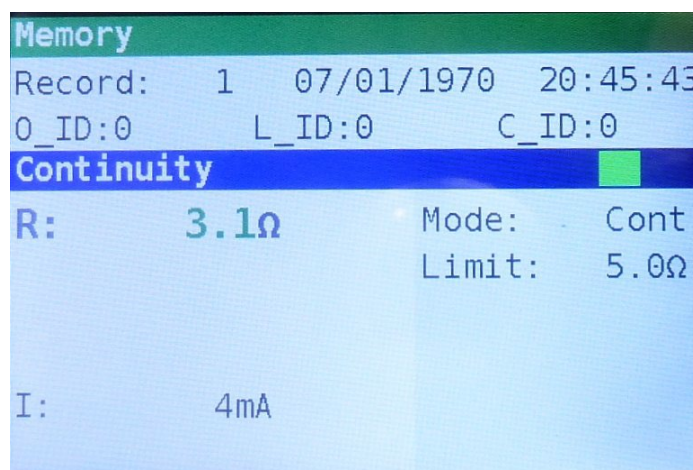

Figure 8.6: Saved results

The record number will change from red to black letters. That means that this result will be saved in memory as record 1.

Each single result can be shown in colored letters:

- Green: measured and passed
- Red: measured but failed
- Black: measured but not judged

In addition the blue function bar contains a colored field that shows the overall result of the measurement:

- Green: measured and passed
- Red: measured but failed
- Brown: measured but not judged

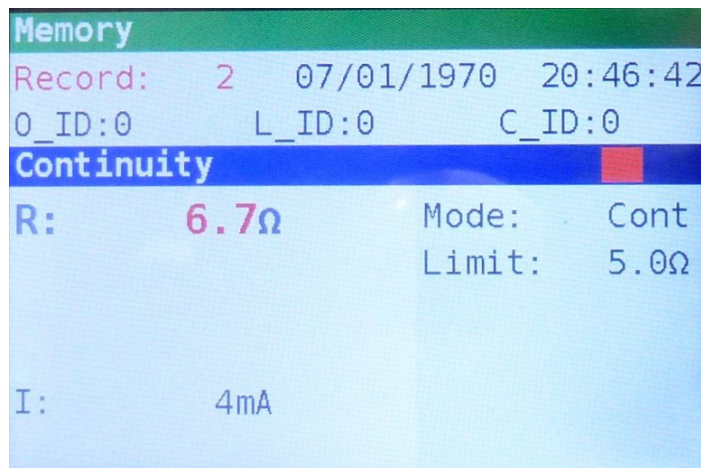

Figure 8.7: failed result

To cancel the saving of the record press **MEM** or **Exit/Back/Return** key instead of **TEST**, the last measurement screen is then shown.

Step 4 Press the **MEM** or **Exit/Back/Return** key to return to last measurement screen or the **▲▼** navigation keys to see a record from the list.

8.3. Recalling results

Step 1 To enter the Memory screen press the **MEM** key.
When no measurement was made, the last record is directly shown.
When a measurement was made, a screen as in figure 8.4 is shown. Press then the **UP** or **DOWN** key to enter the record list.

Step 2 Press the **UP** or **DOWN** key to step through the records.

It is possible to change the IDs of an existing record. Press the **LEFT** key to enter the ID editor, change the IDs and save it. These IDs will not be used for the following new records.

8.4. Deleting results

- Step 1** To enter the Memory screen press the **MEM** key.
When no measurement was made, the last record is directly shown.
When a measurement was made, a screen as in figure 8.4 is shown. Press then the **UP** or **DOWN** key to enter the record list.
- Step 2** Press the **UP** or **DOWN** key to find the record that has to be deleted.
- Step 3** Press the **RIGHT** key, the following screen will be displayed (Figure 8.8).

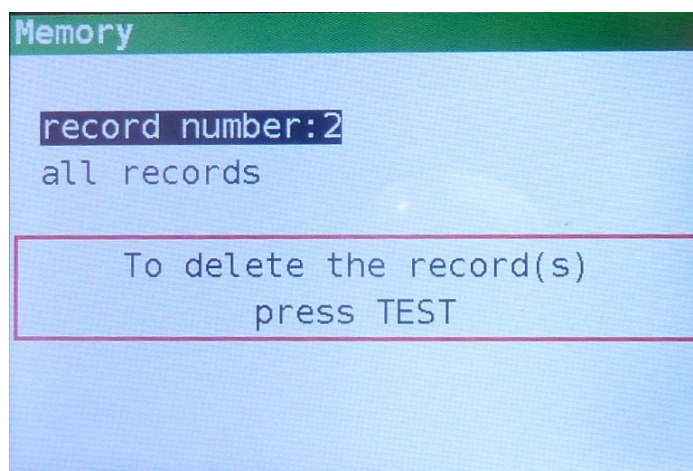

Figure 8.8: delete screen

- Step 4** Press the **TEST** key to delete the selected record and return to the record list
or
- Step 5** Press the **DOWN** key to select all records (Figure 8.9)

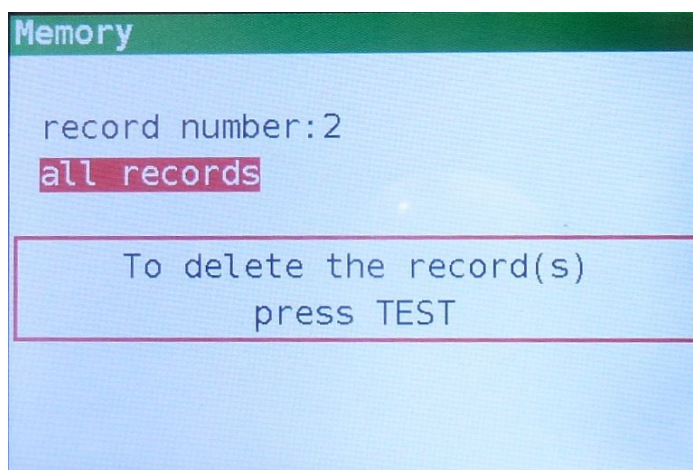

Figure 8.9: delete screen

Then press the **TEST** key to delete all records and return to the measurement screen.

When a single record is deleted, its space in memory is freed and can be reused. The record number of the deleted record however is not used for new records.

When all records are deleted, the complete memory space is freed and all IDs and numbers are reset.

9 USB communication [Voltcraft IST 3000 only]

Stored results can be sent to PC for additional activities like simple report creation and/or further analysis in Excel spreadsheet. MFT connects to PC via USB communication.

9.1. MFT Records - PC software

Downloading stored records from MFT to PC is done using **MFT Records** application. Records are stored on PC in form of *.csv file. Also, records can be exported to Excel spreadsheet (*.xlsx) for quick generation of reports and if required, for further analysis.

The **MFT Records** is a PC software running on Windows platform. In order to install the software and also required USB drivers, installation package (**setupMFT_1_0_0_rev1.exe**) must be started (Figure 9.1).



Figure 9.1: Installation is started by clicking on the setup icon

9.2. Downloading records to PC

Step 1

Disconnect all connection cables and test objects from MFT device.

Step 2

Connect MFT (Figure 9.2) to your PC by means of USB connecting cable (Figure 9.3).



Figure 9.2: USB connector is located on the

top side of the MFT housing



Figure 9.3: USB connecting cable (type A-male to B-male)

USB driver is installed automatically on a free COM port and confirmation that new hardware can be used follows.

Given COM port number can be viewed by means of the Device Manager of your system.

Step 3

Start the **MFT Records** program by clicking on the Desktop shortcut icon (Figure 9.4).



Figure 9.4: Start the MFT Records app by clicking on the Desktop shortcut icon

Step 4

Click on **Scan Ports** (Figure 9.5).

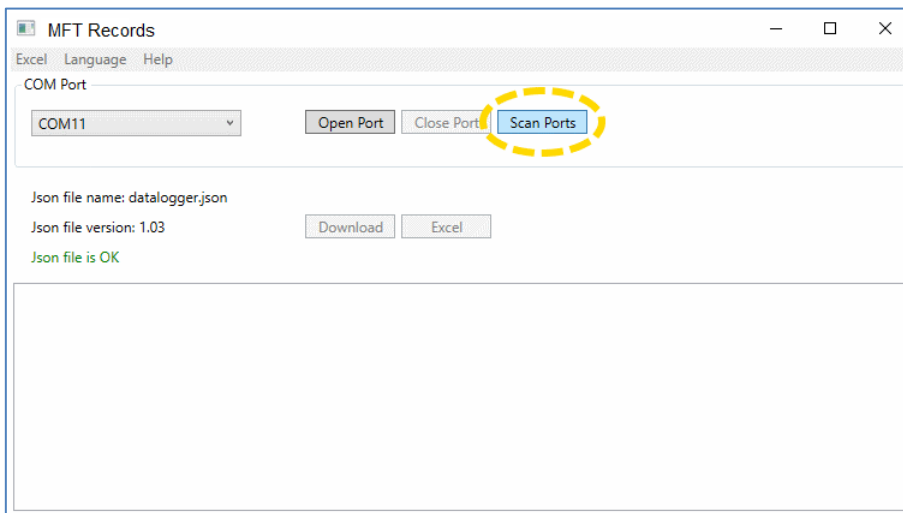

Figure 9.5: Scanning Ports

Step 5

Select appropriate port and click **Open Port** (Figure 9.6).

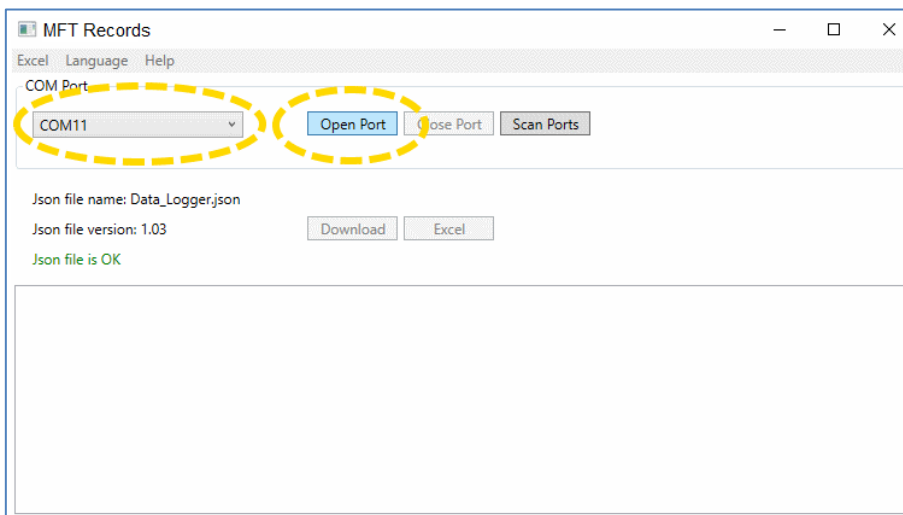

Figure 9.6: Opening Port

Step 6

Click **Download** to initiate data transfer (Figure 9.7). When records are downloaded *.csv file is automatically created.

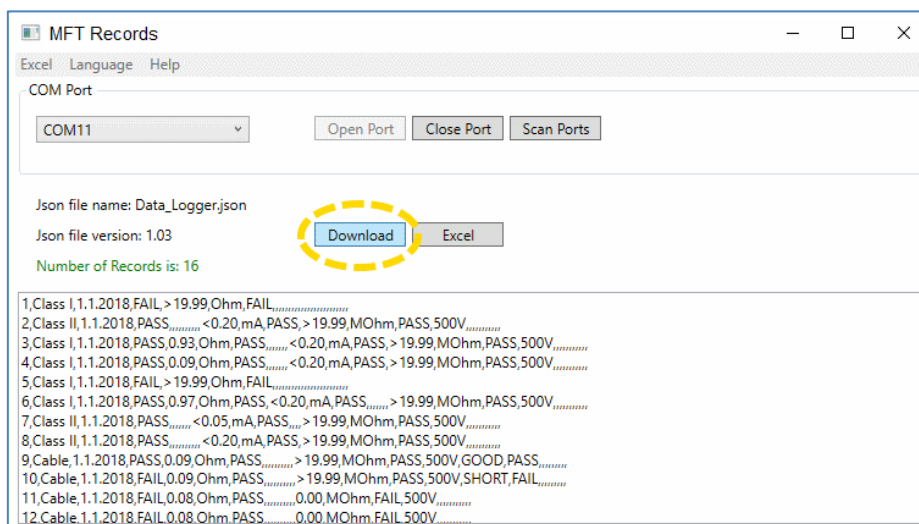

Figure 9.7: Downloading records

Step 7

Click **Excel** button to export all records to Excel file (Figure 9.8). An example excel file is displayed also (Figure 9.9). Default locations for saving *.csv and *.xlsx files are: *Documents/MFT/Csv_Records/* and *Documents/MFT/*.

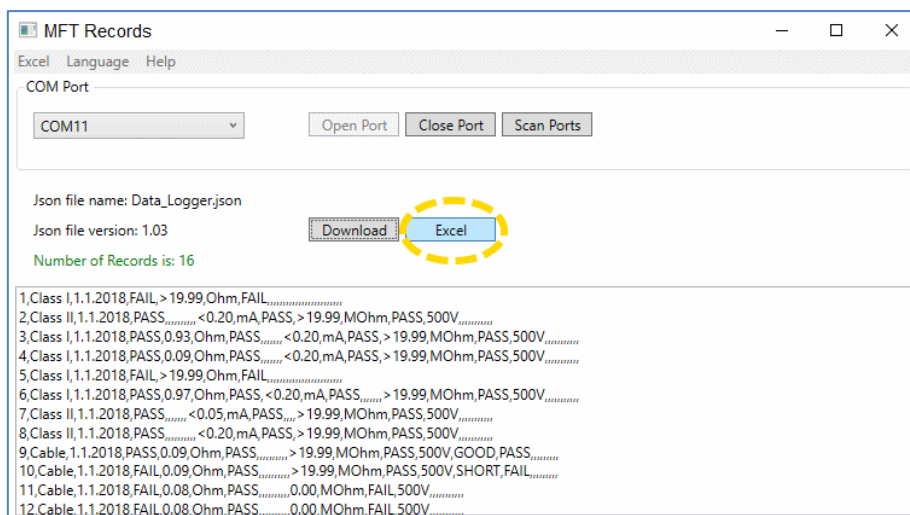

Figure 9.8: Generating Excel file

Record number	Date	Time	Supply system	Test mode	Test result	Limit	Re	Rs	Rh			
1	01/10/2019	12:44:05	TN/TT	Earth resistance - Re	PASS	1Ω	0.09Ω	0.0kΩ	0.0kΩ			
Record number	Date	Time	Supply system	Test mode	Test result	Limit	Re	Rs	Rh			
2	01/10/2019	12:45:05	TN/TT	Earth resistance - Re	FAIL	1Ω	>9999Ω	>60.0kΩ	>60.0kΩ			
Record number	Date	Time	Supply system	Test mode	Test result	Distance	p	Rs	Rh			
3	01/10/2019	12:47:23	TN/TT	Earth resistance - Ro	PASS	1m	0.09Ωm	0.0kΩ	0.0kΩ			
Record number	Date	Time	Supply system	Test mode	Test result	Limit	R					
4	01/10/2019	13:12:07	TN/TT	Continuity - Cont	PASS	20.0Ω	0.7Ω					
Record number	Date	Time	Supply system	Test mode	Test result	Limit	R					
5	01/10/2019	13:14:26	TN/TT	Continuity - Cont	FAIL	20.0Ω	25.7Ω					
Record number	Date	Time	Supply system	Test mode	Test result	Limit	R	R+	R-	I		
6	01/10/2019	13:15:11	TN/TT	Continuity - LowΩ	PASS	20.0Ω	0.09Ω	0.09Ω	0.09Ω	200mA		
Record number	Date	Time	Supply system	Test mode	Test result	Voltage	Limit	R	Um			
7	01/10/2019	13:15:11	TN/TT	R insulation	PASS	500V	0.95MΩ	1.508MΩ	551V			
Record number	Date	Time	Supply system	Test mode	Test result	Type	Time	Current	Limit	Z	Isc	
8	01/10/2019	13:15:11	TN/TT	Line impedance - Line	PASS	gG	0.4s	2A	16.0A	220.2Ω	25.5A	
Record number	Date	Time	Supply system	Test mode	Test result	R	Isc					
9	01/10/2019	14:06:10	LV	Line impedance - Line LV	PASS	220.2Ω	25.5A					
Record number	Date	Time	Supply system	Test mode	Test result	Type	Time	Current	Limit	Z	Isc	
10	01/10/2019	13:15:11	TN/TT	Loop impedance - Loop	PASS	gG	0.4s	2A	16.0A	220.2Ω	25.5A	
Record number	Date	Time	Supply system	Test mode	Test result	R1	I1	R2	I2			
11	01/10/2019	14:06:10	LV	Loop impedance - Loop LV	PASS	220.2Ω	25.5A	220.2Ω	25.5A			
Record number	Date	Time	Supply system	Test mode	Test result	Type	Time	Current	Limit	Z	Isc	
12	01/10/2019	15:15:11	TN/TT	Loop impedance - RCD	PASS	gG	0.4s	2A	16.0A	220.2Ω	25.5A	

Figure 9.8: Generated Excel file example

Disposal

Product



This symbol must appear on any electrical and electronic equipment placed on the EU market. This symbol indicates that this device should not be disposed of as unsorted municipal waste at the end of its service life.

Owners of WEEE (Waste from Electrical and Electronic Equipment) shall dispose of it separately from unsorted municipal waste. Spent batteries and accumulators, which are not enclosed by the WEEE, as well as lamps that can be removed from the WEEE in a non-destructive manner, must be removed by end users from the WEEE in a non-destructive manner before it is handed over to a collection point.

Distributors of electrical and electronic equipment are legally obliged to provide free take-back of waste. Conrad provides the following return options **free of charge** (more details on our website):

- in our Conrad offices
- at the Conrad collection points
- at the collection points of public waste management authorities or the collection points set up by manufacturers or distributors within the meaning of the ElektroG

End users are responsible for deleting personal data from the WEEE to be disposed of.

It should be noted that different obligations about the return or recycling of WEEE may apply in countries outside of Germany.

(Rechargeable) batteries

Remove batteries/rechargeable batteries, if any, and dispose of them separately from the product. According to the Battery Directive, end users are legally obliged to return all spent batteries/rechargeable batteries; they must not be disposed of in the normal household waste.



Batteries/rechargeable batteries containing hazardous substances are labelled with this symbol to indicate that disposal in household waste is forbidden. The abbreviations for heavy metals in batteries are: Cd = Cadmium, Hg = Mercury, Pb = Lead (name on (rechargeable) batteries, e.g. below the trash icon on the left).

Used (rechargeable) batteries can be returned to collection points in your municipality, our stores or wherever (rechargeable) batteries are sold. You thus fulfil your statutory obligations and contribute to environmental protection.

Batteries/rechargeable batteries that are disposed of should be protected against short circuit and their exposed terminals should be covered completely with insulating tape before disposal. Even empty batteries/rechargeable batteries can contain residual energy that may cause them to swell, burst, catch fire or explode in the event of a short circuit.

IST 3000E EVSE Active Test Lead

Operating instructions

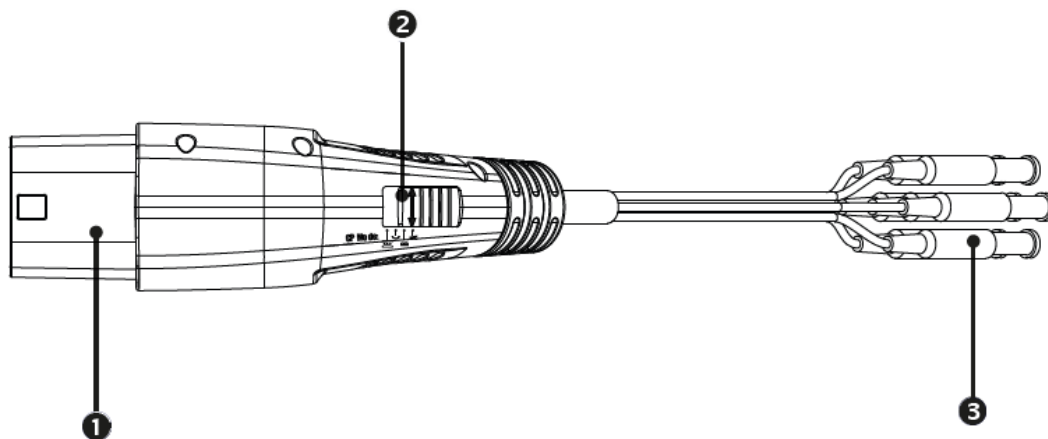

-
- | | |
|---|--|
| 1 | Type-2 plug |
| 2 | Slider switch for CP Mode selection |
| 3 | Test leads with 4 mm safety plugs for L1, L2, L3, N, PE, CP and PP |
-

Adapter is equipped with 0,5 m test leads.

References marked on instrument or in instruction manual



Warning of a potential danger, follow with instruction manual.



Caution! Dangerous voltage. Danger of electrical shock.



Ground terminal



Continuous double or reinforced insulation category II IEC 536 / DIN EN 61140.



Conformity symbol, the instrument complies with the valid directives. It complies with the EMC Directive (2014/30/EU), Standard EN 61326 is fulfilled. It also complies with the Low Voltage Directive (2014/35/EU) Standards EN 61010-1 and EN 61010-031.

Safety references



- The respective accident prevention regulations established by the professional associations for electrical systems and equipment must be strictly met at all times.
- In order to avoid electrical shock, the valid safety and VDE regulations regarding excessive contact voltages must receive utmost attention, when working with voltages exceeding 120 V (60 V) DC or 50 V (25 V) rms AC. The values in brackets are valid for limited ranges (as for example medicine and agriculture).
- Measurements in dangerous proximity of electrical systems are only to be carried out in compliance with the instructions of a responsible electronics technician, and never alone.
- If the operator's safety is no longer ensured, the instrument is to be put out of service and protected against use. The safety is no longer insured, if the instrument:
 - shows obvious damage
 - does not carry out the desired measurements
 - has been stored for too long under unfavourable conditions
 - has been subjected to mechanical stress during transport.
- The instrument may only be used within the operating ranges as specified in the technical data section.
- Avoid any heating up of the instrument by direct sunlight to ensure perfect functioning and long instrument life.
- The opening of the instrument for fuse replacement, for example, may only be carried out by professionals. Prior to opening, the instrument has to be switched off and disconnected from any current circuit.
- The instrument may only be used under those conditions and for those purposes for which it was conceived. For this reason, in particular the safety references, the technical data including environmental conditions and the usage in dry environments must be followed.

When modifying or changing the instrument, the operational safety is no longer ensured.

Testing

Purpose of the EVSE Active Test Lead accessory

The EVSE Active Test Lead is an accessory to support all relevant measurements of a Multifunction Tester (MFT) to simplify the wiring between the EVSE charging point (Type-2 connector) and the measurement inputs of the Multi Function Tester. All wires of the charging connector are available: L1, L2, L3, N, PE, CP and PP. This allows to perform typical measurements: Voltage, frequency, phase indication, phase sequence, various RCD tests and measurements, insulation resistance, low ohm measurements, line and loop impedances,

Test procedure:

Connect the needed 4 mm test plugs of the active test lead to the Multi Function Tester.

- Select CP Mode "A" with the slider switch.
- Connect the active test lead to the Type-2 connector of the charging point.
- Select CP Mode "B" with the slider switch, the charging point should show "ready to charge".
- Select CP Mode "C" with the slider switch, the charging point should start charging.
- Perform all measurements in active stage of the charging point (voltage and similar).
- After you completed all your measurements select CP Mode "A" with the slider switch to stop charging.
- Unplug active test lead from the charging point.

Proximity Pilot (PP) State (Cable Simulation)

The active test lead is configured internally (680 Ohm between PP and PE) to setup 20 A current capability.

Control Pilot (CP) State (Vehicle Simulation)

With the CP Mode slider switch various vehicle states can be simulated. Vehicle states are simulated with different resistances connected between CP and PE conductors. Correlation between resistance and vehicle states is shown in the table below.

Vehicle State	State Description	CP-PE Resistance	CP Terminal Voltage
A	Electric vehicle not connected	Open (∞)	± 12 V @ 1 kHz
B	Vehicle connected, not ready to charge	2.74 K	+9 V/-12 V @ 1 kHz
C	Electric vehicle connected ready to charge, ventilation not required	882 Ω	+6 V/-12 V @ 1 kHz
[E]	CP Error „E“ (see below)	0 Ω	0 V

CP Signal output terminals

CP output terminals are short connected to the CP and PE conductors of the tested charging station via the test cable. Use an oscilloscope to check the waveform and amplitude of the CP signal.

Control Pilot function uses Pulse Width Modulation (PWM) to code communication between a vehicle and charging station. The duty cycle of the PWM signal defines the possible available charging current, while amplitude defines charger state.

For details of communication protocol please refer to IEC/EN 61851-1 and the documentation of the manufacturer of the charging station.

Important note: In the case of wrong wiring of the charging station, low signal CP test terminals can get high, live hazard voltage.

CP Error “E” simulation

“E” - CP Error simulation could be realized by pushing the slider switch into (spring loaded) position[E]. This will simulate behaviour of the station when there is a short circuit between CP and PE through internal diode (acc. to standard IEC/EN 61851-1).

In the case of CP Error (“E” is pushed), result should be aborting of the charging process and new charging process is prevented.

Measuring terminals

Measuring terminals (no. 1 and 2 on the picture) are directly connected to L1, L2, L3, N and PE conductors of the tested charging station. It is allowed to use these for measuring purposes only. It is not allowed to draw current over a longer period or supply anything else. An appropriate measurement instrument is needed.

Cleaning

If the instrument is dirty after daily usage, it is advised to clean it by using a humid cloth and a mild household detergent. Prior to cleaning, ensure that instrument is switched off and disconnected from external voltage supply and any other instruments connected (such as UUT, control instruments, etc.). Never use acid detergents or solvent for cleaning.

Specifications

Input voltage: 230 / 400 V/AC 3~ 50/60 Hz
Measurement category: CAT II 300 V
Mains socket rating: max. 10 A
PP simulation: setup internally to 20 A
CP simulation: States A, B, C
Error simulation: CP error "E"
Test connector type: IEC 62196-2 Type 2 male
Test cable length: 0,5 m
Working temperature: 0 to +40 °C
Storage temperature: -10 to +50 °C
Humidity: 0 - 80 % RH
Compliance to: IEC 61010-1 / IEC 61010-031



This is a publication by Conrad Electronic SE, Klaus-Conrad-Str. 1, D-92240 Hirschau (www.conrad.com).

All rights including translation reserved. Reproduction by any method, e.g. photocopy, microfilming, or the capture in electronic data processing systems require the prior written approval by the editor. Reprinting, also in part, is prohibited. This publication represent the technical status at the time of printing.

Copyright 2025 by Conrad Electronic SE.

2997218_2997219_2997220_V1_0825_02_m_en