

- 3W to 14W Power Rating.
- All Welded Construction.
- Non-Flammable Enamel Coating.
- High Overload and Pulse Handling Capability.
- Suitable for High Speed Lead Forming Machines.
- Reference Standards.
 - BS CECC 40201-002 (BSE9114N001)
 - CECC-40201-001
 - JSS 50402 [RFHT-1 STYLES 2.5 to 12]



Type	Power @25°C Watts	Power @70°C Watts	Voltage Max Volts	Ohmic Range Ohms	Ref. Standards*			Additional Specifications	
					BS-CECC 40201-002	CECC 40201-001	JSS RFHT-1	TCR	Std. < +200 ppm/°C, Typ. < +100 ppm/°C
V3	3	2.6	100	0R1 - 10K	JB	RB59	2.5	Derating	From 25°C to 350°C
V5	5	4.3	160	0R1 - 20K	HB	RB61	-	Climatic Cat.	55 / 200 / 56
V7	7	6	200	0R1 - 22K	KB	RB57	6	Ambient	-55°C to 200°C
V10	10	9	500	0R1 - 68K	LB	RB60	9	Load Life	ΔR < 5%
V14	14	12	750	0R1 - 100K	MB	-	12	Solderability	95% Coverage - MIL Std. 202F, Test 208

Test Methods	Test Conditions	Test Limits
Short Term Overload	10 × Rated Power for 5 seconds	ΔR < 1% + 0R05
Endurance at Room Temperature	Rated Power @25°C (1.5 hrs ON, 0.5 hrs OFF)	ΔR < 5% + 0R05
Thermal Shock (Rapid Change of Temp.)	5 Cycles, -55°C to 200°C	ΔR < 1% + 0R05
Robustness of Terminations	As per Clause C1-4.14 of BS-CECC 40201-002	ΔR < 1% + 0R05
Resistance to Soldering Heat	10 Seconds dip in Solder Bath at 260°C	ΔR < 1% + 0R05
Vibration	Freq: 10-500Hz, Amplitude: 0.75mm/10g, Accln.: 6hrs in each Axis	ΔR < 1% + 0R05
Bump Test	4000 Bumps at 40g Acceleration (Accln.)	ΔR < 1% + 0R05
Long Term Damp Heat	90% - 95% RH @ 40°C Ambient Temperature for 56 days	ΔR < 5% + 0R05
Climatic Sequence	As per Clause C1 - 4.20.8 of BS-CECC 40201-002	ΔR < 5% + 0R05
Temperature Rise	Max. Surface Temp. Rise @Rated Power and @25°C ambient	T < 380°C

ARCOL UK Limited,
Threemilestone Ind. Estate,
Truro, Cornwall, TR4 9LG, UK.
T +44 (0) 1872 277431
F +44 (0) 1872 222002
E sales@arcolresistors.com

www.arcolresistors.com

The information contained herein does not form part of a contract and is subject to change without notice. Arcol operate a policy of continual product development, therefore, specifications may change.

It is the responsibility of the customer to ensure that the component selected from our range is suitable for the intended application. If in doubt please ask Arcol.

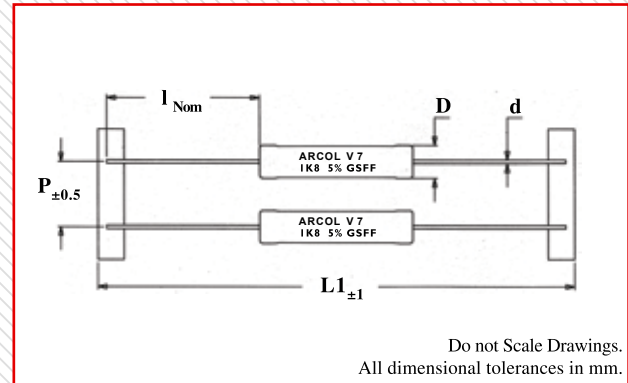
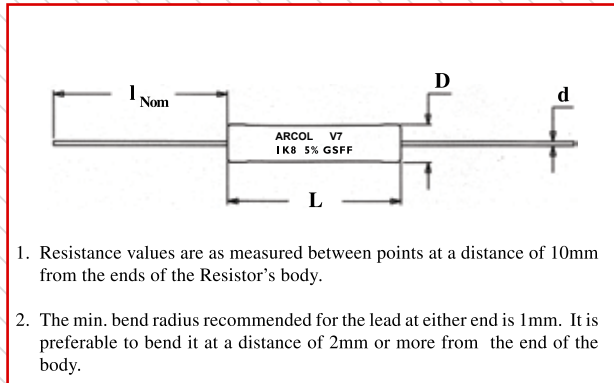
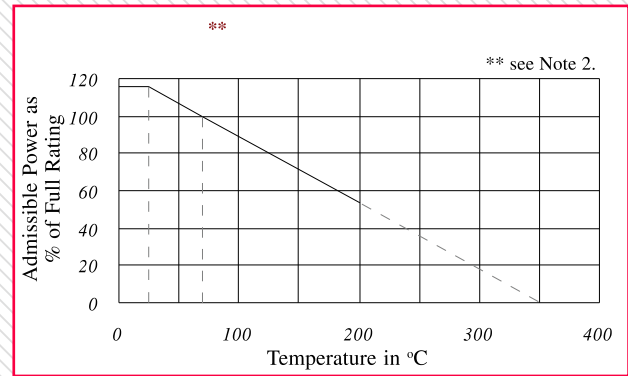
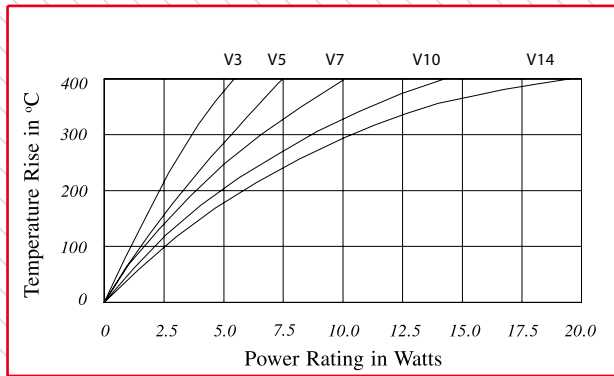

Type	L	D	I***	d	P	L1
	Max	Max	Nom	+0.08 mm -0.05 mm		
V3	12.7	5.6	26.5	0.80	10.0	65.0
V5	23.0	7.0	26.5	0.80	10.0	75.0
V7	22.2	8.0	26.5	0.80	10.0	74.0
V10	38.1	8.0	35.0	0.80	NA	NA
V14	53.5	8.0	35.0	0.80	NA	NA

*** 38mm lead lengths can be taken up for supply on request.

Type	L	D	I****	d	P	L1
	Max	Max	Nom	+0.00315" -0.00197"		
V3	0.500	0.220	1.043	0.0315	0.394	2.559
V5	0.906	0.276	1.043	0.0315	0.394	2.953
V7	0.874	0.315	1.043	0.0315	0.394	2.913
V10	1.500	0.315	1.378	0.0315	NA	NA
V14	2.106	0.315	1.378	0.0315	NA	NA

**** 1.5" lead lengths can be taken up for supply on request.

Type	Ohmic Value	Tolerance	Packing Style *	Release Condition	Standard / Non-Std. Leads
V3	0.1 Ohm » 0R1 / R10 1 Ohm » 1R0 1 KOhm » 1K0 10.7 KOhm » 10K7	1% » F 2% » G 5% » J 10% » K	Bulk » B Tape&Reel » T Ammo » A Rondo » R	Commercial » X CECC » F JSS » J BS-CECC » B	Standard » S 38mm / 1.5" » L Others » M

A Sample Part No.: V3 1K0 JTXS * V3, V5 & V7 can be supplied in Style B/T/A & V10 & V14 can be only supplied in Style R.

- On request we undertake tests for Batch Acceptance to a specified Reference Standard.
- The Derating Curve specifies the maximum allowable Power at a particular ambient temperature while ensuring that the maximum surface temperature remains within the designed limit.
- When the Resistor is subjected to a Pulse Load, please ensure that the *average* Power dissipated remains below the rated Power specified.
- Resistor performance with Pulse Loads will have to be application tested. Please utilise our Pulse Application Questionnaire for selecting a suitable type or for requesting any design-in assistance from us.