



SPL3P1-02-00-03-00_1
SPP3P1-30-00-51-00_1

General Specifications :

- * Program Memory Area : 196K
Volatile Memory Area: 27K
- * 9 pieces Digital Input (NPN / PNP)
- * 6 pieces Digital Output (Active High)
- * Ethernet 10/100 Mbit
Easy access via the Internet with WEB QUICK CONNECT
Module access via Web Browser with IPERTU SCADA
- * Modbus RTU communication protocol with RS232
- * Modbus RTU communication protocol with RS485
- * USB – Device (For device configuration)
- * Modular connection (up to 16 extension modules can be connected)
- * Led indicators:
 - RUN, USB, RS-485
 - Active Input led indicators
 - Active Output led indicators

Technical Specifications

Module Type	SPL3P1-02-00-03-00_1	SPP3P1-30-00-51-00
Supply Voltage	24 VDC ± %20 (19,2 VDC - 28,8 VDC)	
Power Consumption	1,5W	2W
Communication	RS-232, RS-485 Modbus RTU, Ethernet	
USB Device	Mini USB, USB 2.0	
Non-Volatile Memory	4K, 10 years permanent memory life	
Execution Speed	LD instruction duration : 30nsec/instruction MOV instruction duration : 80nsec/instruction I/O refresh duration : ~300µsec/module Peripheral service duration : ~10µsec/cycle	
Digital Inputs		
Number of Inputs	9	
Type	NPN / PNP	
Nominal Input Volt.	24 VDC	
Active Level	Low Level < 7 VDC, High Level > 10 VDC	
Input Resistance	> 5,9 kΩ	
Maximum Current	6 mA	
Maximum frequency	20 kHz (3 x A/B channel encoder connection)	200 kHz (3 x A/B channel encoder connection)
Detection Speed	Filter option between 1-500 msec	
Digital Outputs		
Number of Outputs	6	
Digital Output Current	0,3 A (one channel), 1,8 A (total COM current)	
Transistor Power	External 24VDC supply must be connected	
Maximum Frequency	6 channel 10 KHz, PWM and PTO	6 channel 100 KHz, PWM and PTO
Protection	-	
Led Indicators		
RUN	"Green" in RUN mode "Red" in STOP mode "Yellow" in RESET mode Flashes 1 sec in case of any error (low voltage, bus communication error) Flashes 0.2 sec ON / 2 sec OFF if the device in Software Boot Mode	
Ethernet	Yellow : Speed, Green : Link	
USB	Always ON if the USB cable plugged, flashes during data transfer	

RS485	Flashes during Modbus data transfer
Digital Input	ON when input active, OFF otherwise
Transistor Output	ON when output active, OFF otherwise
Operation / Storage Environment	
Operation Temp.	-10°...+60° C
Storage Temperature	-20°...+70° C
Isolation	* There is no isolation between Power Input and RS485 & USB * 1000 VAC between Power Input and Digital Inputs * 1000 VAC between Power Input and Digital Outputs

Volatile Memory Area Map

Address Name	Address Range	Address Type	Definition
X	0 – 127	BOOL	Logic Input Memory Area
Y	0 – 127	BOOL	Logic Output Memory Area
AI	0 – 31	WORD	Analog Input Memory Area
AO	0 – 31	WORD	Analog Output Memory Area
M	0 – 7999 8000 - 8191	BOOL	Bit Memory Area Specific Bit Memory Area
D	0 – 7999 8000 - 8191	WORD	Data Memory Area Specific Data Memory Area
S	0 – 1023	BOOL	Status Bits
CV	0 – 199 200 – 255	WORD DWORD	Counter Memory Area
TV	0 – 255	WORD	Timer Memory Area
C	0 – 255	BOOL	Counter Bit Memory Area
T	0 – 255	BOOL	Timer Bit Memory Area

Volatile Memory Area Modbus Slave Addresses

Register	Address Range	Address Type	Read Func.	Write Func.	Modbus Address	Offset
X	0 – 127	BOOL	F2	-	100001	0
EX	0 – 479	BOOL	F2	-	101001	1000
Y	0 – 127	BOOL	F1	F5 / F15	006001	6000
EY	0 – 479	BOOL	F1	F5 / F15	007001	7000
S	0 – 1023	BOOL	F1	F5 / F15	012001	12000
T	0 – 255	BOOL	F1	F5 / F15	017001	17000
C	0 – 255	BOOL	F1	F5 / F15	018001	18000
M	0 – 8191	BOOL	F1	F5 / F15	019001	19000
AI	0 – 31	WORD	F4	-	336001	36000
EAI	0 – 159	WORD	F4	-	337001	37000
AO	0 – 31	WORD	F3	F6 / F16	438001	38000
EAO	0 – 159	WORD	F3	F6 / F16	439001	39000
D	0 – 8191	WORD	F3 / F4	F6 / F16	440001 / 340001	40000
CV	0 – 199	WORD	F3	F6 / F16	455001	55000
TV	0 – 255	WORD	F3	F6 / F16	456001	56000
CV32	200 – 255	DWORD	F3	F6 / F16	457001	57000

Specific Bit Memory Area Definitions

Address	Definition	Non-volatile	R / W	Power ON	STOP > RUN	RUN > STOP
M8000	Normal open contact	-	R	OFF	ON	OFF
M8001	Normal close contact	-	R	ON	OFF	ON
M8002	Enable single positive pulse at the moment when RUN is activate	-	R	OFF	ON	OFF
M8003	Enable single negative pulse at the moment when RUN is activate	-	R	ON	OFF	ON
M8004	10ms clock pulse, 5ms ON / 5ms OFF	-	R	OFF	-	-
M8005	100ms clock pulse, 50ms ON / 50ms OFF	-	R	OFF	-	-
M8006	1s clock pulse, 0.5s ON / 0.5s OFF	-	R	OFF	-	-
M8007	1 min clock pulse, 30s ON / 30s OFF	-	R	OFF	-	-
M8008	General error	-	R	-	-	-
M8009	Hard fault error	X	R	-	-	-
M8010	Memory management fault error	X	R	-	-	-
M8011	Memory access fault error	X	R	-	-	-
M8012	Undefined instruction or illegal state fault error	X	R	-	-	-
M8013	Watchdog timer (ON: PLC WDT time out)	X	R	-	-	-
M8014	Expansion module connected	-	R	-	-	-
M8015	Expansion module Init Error	-	R	-	-	-
M8016	Expansion module Type Mismatch	-	R	-	-	-
M8017	Expansion module Count Mismatch	-	R	-	-	-
M8018 - M8033	Expansion module 1 Comm. Error - Expansion module 16 Comm. Error	-	R	-	-	-
M8034 - M8049	Expansion module 1 Conf. Error - Expansion module 16 Conf. Error	-	R	-	-	-
M8050	Battery Low	-	R	-	-	-
M8051	Battery Dead	-	R	-	-	-
M8052	PLC Cycle Timeout	-	R	-	-	-
M8053	PLC User Timer Cycle Timeout	-	R	-	-	-
M8054	24VDC Fault	-	R	-	-	-
M8055	All RetainMem cleared	-	R	-	-	-
M8056	Device reset	-	R / W	-	-	-
M8057	PLC status (RUN / STOP), ON = RUN	-	R / W	-	-	-
M8058	Reserved	-	-	-	-	-
M8059	RS232 settings update	-	R / W	-	-	-
M8060	RS485 settings update	-	R / W	-	-	-
M8061	Ethernet settings update	-	R / W	-	-	-
M8062	HSC0 settings update	-	R / W	-	-	-
M8063	HSC1 settings update	-	R / W	-	-	-
M8064	HSC2 settings update	-	R / W	-	-	-
M8065	Reserved	-	-	-	-	-
M8066	Shift instruction overflow bit	-	R	OFF	-	-
M8067	Shift instruction zero flag	-	R	OFF	-	-
M8068	BCD conversion error flag	-	R	OFF	-	-
M8069	Operation result overflow	-	R	OFF	-	-
M8070	Negative result of operation	-	R	OFF	-	-
M8071	The operation result is zero	-	R	OFF	-	-
M8072	Divide by zero	-	R	OFF	-	-
M8073	The illegal use of operands	-	R	OFF	-	-
M8074	HSO0 / Y0 is outputting pulse	-	R	OFF	-	-
M8075	HSO1 / Y1 is outputting pulse	-	R	OFF	-	-
M8076	HSO2 / Y2 is outputting pulse	-	R	OFF	-	-
M8077 - M8191	Reserved	-	-	-	-	-

Specific Data Memory Area Definitions

Address	Definition	Non-volatile	R / W
D8000	RS232 Communication Type	X	R / W
D8001	RS232 Slave ID	X	R / W
D8002	RS232 Baudrate	X	R / W
D8003	RS232 Parity	X	R / W
D8004	RS232 Stop Bit	X	R / W
D8005	Reserved	X	R / W
D8006	RS232 Timeout	X	R / W
D8007	RS232 Retransmission times	X	R / W
D8008	RS485 Communication Type	X	R / W
D8009	RS485 Slave ID	X	R / W
D8010	RS485 Baudrate	X	R / W
D8011	RS485 Parity	X	R / W
D8012	RS485 Stop Bit	X	R / W
D8013	Reserved	X	R / W
D8014	RS485 Timeout	X	R / W
D8015	RS485 Retransmission times	X	R / W
D8016	HSC0 Type	X	R / W
D8017	HSC1 Type	X	R / W
D8018	HSC2 Type	X	R / W
D8019 - D8021	Reserved	X	R / W
D8022 - D8025	Ip (0 ... 3)	X	R / W
D8026 - D8029	Netmask (0 ... 3)	X	R / W
D8030 - D8033	Gateway (0 ... 3)	X	R / W
D8034 - D8078	Reserved	-	-
D8079	Second of RTC	-	R
D8080	Minute of RTC	-	R
D8081	Hour of RTC	-	R
D8082	Day of RTC	-	R
D8083	Month of RTC	-	R
D8084	Weekday of RTC	-	R
D8085	Year of RTC	-	R
D8086	Reserved	-	R / W
D8087- D8089	MAC address (0 ... 2)	-	R
D8090	Displaying the firmware version	-	R
D8091	Current scan time (Unit: 0.1ms)	-	R
D8092	Minimum scan time (Unit: 0.1ms)	-	R
D8093	Maximum scan time (Unit: 0.1ms)	-	R
D8094 - D8095	System Working Time (Low word, High word)	-	R
D8096	User Timer1 Block Time (ms)	-	R
D8097	Battery Volt Status (0.01V)	-	R
D8098	Number of connected expansion modules	-	R
D8099 - D8114	Expansion module 1 error code Expansion module 16 error code	-	R
D8115	CPU Error Code	-	R
D8116 - D8117	Accumulative pulse number of HSO0 / Y0 pulse output (Low word, High word)	X	R / W

D8118 - D8119	Accumulative pulse number of HSO1 / Y1 pulse output (Low word, High word)	X	R / W
D8120 - D8121	Accumulative pulse number of HSO2 / Y2 pulse output (Low word, High word)	X	R / W
D8122 - D8128	Reserved	-	-
D8129	Start/End frequency of the pulse output HSO0 (Default:100Hz)		R / W
D8130	Start/End frequency of the pulse output HSO1 (Default:100Hz)		R / W
D8131	Start/End frequency of the pulse output HSO2 (Default:100Hz)		R / W
D8132	Ramp up/down time for HSO0 (Default:100ms)		R / W
D8133	Ramp up/down time for HSO1 (Default:100ms)		R / W
D8134	Ramp up/down time for HSO2 (Default:100ms)		R / W
D8135	HSO Rest Time for HSO0,1,2 (Default:1000ms)		R / W
D8136	Unfiltered Inputs (I0-I9)		R / W
D8137 - D8191	Reserved	-	-

Installation & Wiring

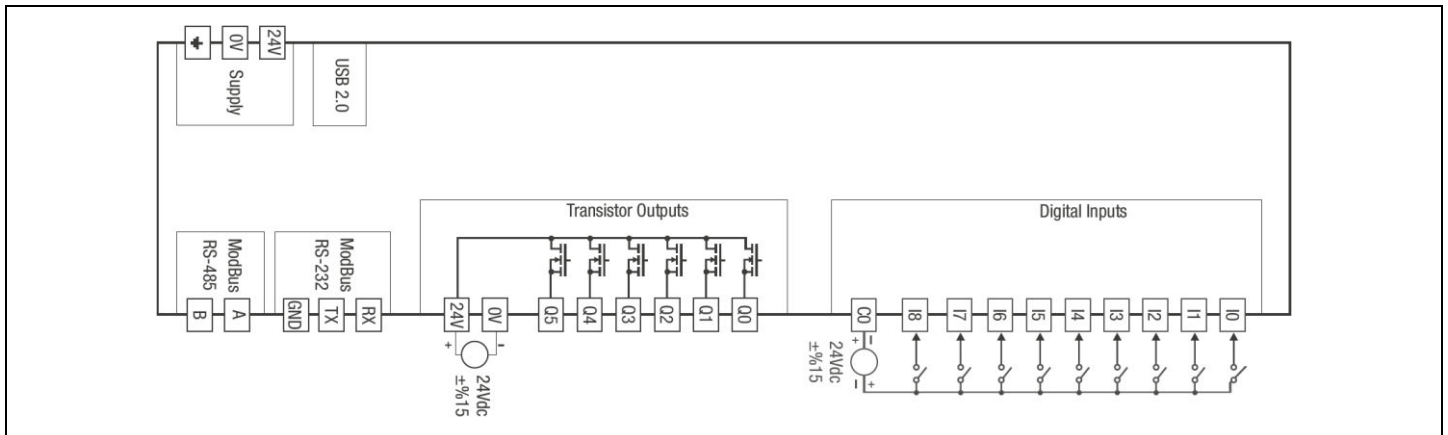

* Do not connect AC Power to any I/O terminal, otherwise serious damage may occur in module. Please check all wiring prior to energizing device. In order to prevent electromagnetic interference, be sure the grounding made corrected. Connect ground terminal in the power input connector to the overall system ground. Don't touch any terminals after energizing the device, in case of need to touch any terminal, de-energize the device before connection.

* For digital input connections; In case of using encoder, as fast counter, use the encoders original cables. Keep the cables away from power cables in order to prevent electrical interference. Ground the encoders screen cables to device ground.

* For Fast Digital Input counter (encoder) connections; For HSCO I0 = A, I1 = B; For HSC1 I3 = A, I4 = B and For HSC2 I6 = A, I7 = B

* For RS232 communication connection; Use shielded communication cable and ground the shield connection to power input earth terminal.

* For RS485 communication connection; Connect the termination resistor (120R) between A & B terminal of the CPU (PLC) module, connected left of the extension module group. In case of more than one module group, connect it between the A & B terminals of the CPU (PLC) module, connected left of the extension module group, at the end of the communication line. Use shielded and twisted-pair communication cable. Ground the shield connection of the cable to power input earth terminal.

Dimensions

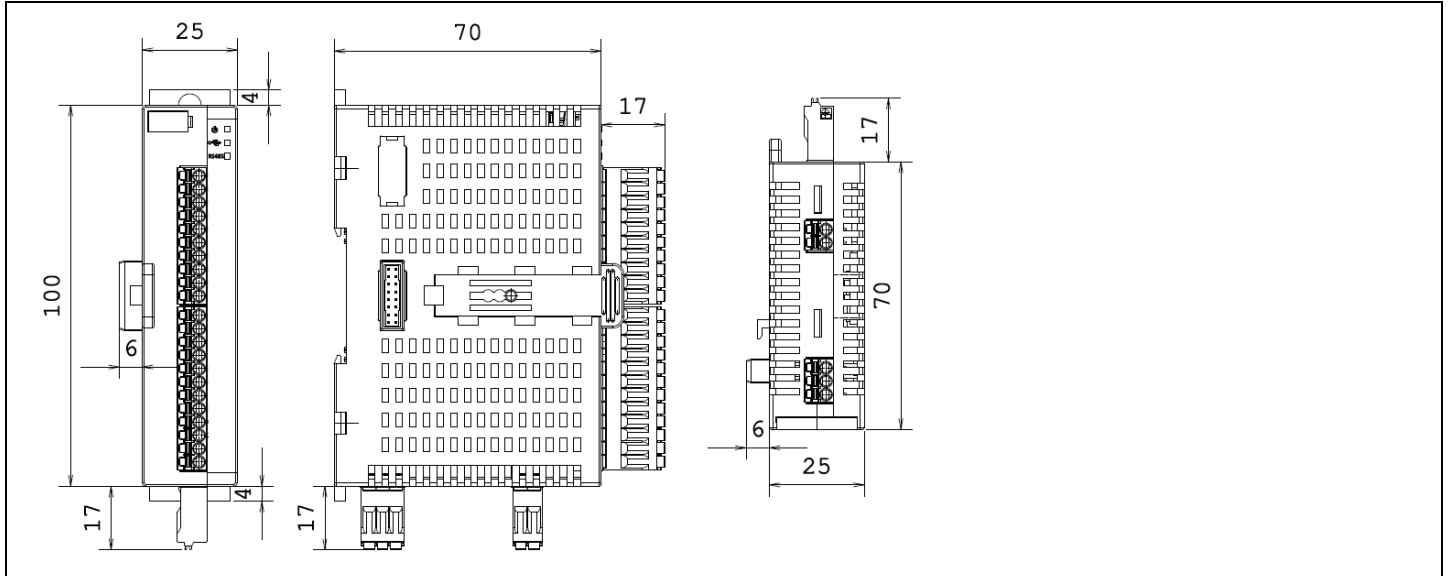

Product Order Codes

Slim CPU Module with Digital Input / Output	Digital Input	Analog Input	Digital Output	Analog Output	ETH	USB	RS232	RS485
Basic : SPL3P1-02-00-03-00_1	9 x NPN / PNP Max. 20 kHz	-	6 x Transistor Max. 10 kHz	-	+	+	+	+
Plus : SPP3P1-30-00-51-00_1	9 x NPN / PNP Max. 200 kHz	-	6 x Transistor Max. 100 kHz	-	+	+	+	+