





Pneumatically operated 2/2 way Valve

- Stainless steel or brass body with threaded connection
- High service life
- Compact design
- Variant for steam applications available

Product variants described in the data sheet may differ from the product presentation and description.

Can be combined with

- | | | |
|---|---|---|
|  | Type 6014
Plunger valve 3/2-way direct-acting | ▶ |
|  | Type 8640
Modular valve island for pneumatics | ▶ |
|  | Type 8644
AirLINE SP electropneumatic automation system | ▶ |

Type description

The externally piloted 2-way valve is operated by a diaphragm actuator. A double spindle seal guarantees high tightness and a high service life.

The compact actuator housing is made out of chemical resistant plastic and ideal for customer specific multifunction block solutions.

This low maintenance and robust valve can be supplemented by a large accessory program.

Table of contents

1. General technical data	3
2. Control functions	3
3. Approvals and conformities	4
3.1. General notes.....	4
3.2. Conformity	4
3.3. Standards.....	4
3.4. Explosion protection	4
4. Materials	5
4.1. Bürkert resistApp	5
4.2. Material specifications	5
5. Dimensions	6
6. Performance specifications	7
6.1. Pressure range	7
6.2. Operating pressure/pilot pressure diagram	7
7. Ordering information	7
7.1. Bürkert eShop	7
7.2. Bürkert product filter	7
7.3. Ordering chart	8

1. General technical data

Product properties	
Dimensions	Further information can be found in chapter “5. Dimensions” on page 6.
Material	
Body	Brass, stainless steel
Inner part of valve	Stainless steel
Actuator	Epoxy resin
Seal	NBR, FKM, PTFE/FKM, EPDM, PTFE/EPDM
Nominal diameter	DN 10...DN 25
Performance data	
Pilot pressure	Further information can be found in chapter “6. Performance specifications” on page 7.
Medium data	
Operating medium	
With NBR	Neutral mediums, e.g. compressed air, natural gas, water, hydraulic oil
With FKM	Per-solution, oxygen, hot air
With EPDM	Oil and fat-free mediums, e.g. hot water, alkaline washing and bleaching lyes
With PTFE/EPDM (PTFE seal with EPDM O-ring)	Oil and fat-free mediums, e.g. hot water and steam
With PTFE/FKM (PTFE seal with FKM O-ring)	Hot oils, hydrocarbons, aromatics and steam
Medium temperature	
With NBR	- 10 °C...+90 °C
With FKM	- 10 °C...+ 100 °C
With EPDM	- 10 °C...+ 100 °C
With PTFE/EPDM	- 10 °C...+ 140 °C
With PTFE/FKM	- 10 °C...+ 140 °C
Viscosity	Max. 100 mm ² /s
Control medium	Neutral gases and liquids, in particular air, water, hydraulic liquids up to max. +90 °C
Approvals and conformities	
Explosion protection	Further information can be found in chapter “3. Approvals and conformities” on page 4.
Environment and installation	
Ambient temperature	- 10 °C...+90 °C
Installation position	As required, preferably with actuator upright

2. Control functions

Symbol	Description
	Control function A (CF A) Pneumatically operated 2/2-way on/off valve Flow direction below seat Normally closed by spring force
	Control function B (CF B) Pneumatically operated 2/2-way on/off valve Flow direction above seat Normally opened by spring force
	Control function I (CF I) Pneumatically operated 2/2-way on/off valve on either side Flow direction below seat Switching position dependent on external control

DTS 1000010919 EN Version: I Status: RL (released | freigegeben | valide) printed: 13.12.2023

3. Approvals and conformities

3.1. General notes

- The approvals and conformities listed below must be stated when making enquiries. This is the only way to ensure that the product complies with all required specifications.
- Not all available versions can be supplied with the below mentioned approvals or conformities.

3.2. Conformity



In accordance with the Declaration of Conformity, the product is compliant with the EU Directives. This includes the following directives:

- Pressure Equipment Directive 2014/68/EU
- Machinery Directive 2006/42/EG

3.3. Standards

The applied standards which are used to demonstrate compliance with the EU Directives are listed in the EU-Type Examination Certificate and/or the EU Declaration of Conformity.

3.4. Explosion protection

Approval	Description																
 	<p>Optional: Explosion protection As a category 2 device suitable for zone 1/21 and zone 2/22 (optional).</p> <p>ATEX: EPS 18 ATEX 2 008 X II 2G Ex h IIC T4...T2 Gb II 2D Ex h IIIC T135 °C...T300 °C Db</p> <p>IECEX: IECEX EPS 18.0007 X Ex h IIC T4...T2 Gb Ex h IIIC T135 °C...T300 °C Db</p> <table border="1" style="width: 100%; border-collapse: collapse;"> <thead> <tr> <th style="width: 40%;">Temperature class</th> <th style="width: 15%;">T2</th> <th style="width: 15%;">T3</th> <th style="width: 15%;">T4</th> </tr> </thead> <tbody> <tr> <td>Permissible surface temperature</td> <td>+300 °C</td> <td>+200 °C</td> <td>+135 °C</td> </tr> <tr> <td>Ambient temperature</td> <td>-40...+130 °C</td> <td>-40...+130 °C</td> <td>-40...+100 °C</td> </tr> <tr> <td>Maximum medium temperature</td> <td>+285 °C</td> <td>+185 °C</td> <td>+125 °C</td> </tr> </tbody> </table>	Temperature class	T2	T3	T4	Permissible surface temperature	+300 °C	+200 °C	+135 °C	Ambient temperature	-40...+130 °C	-40...+130 °C	-40...+100 °C	Maximum medium temperature	+285 °C	+185 °C	+125 °C
Temperature class	T2	T3	T4														
Permissible surface temperature	+300 °C	+200 °C	+135 °C														
Ambient temperature	-40...+130 °C	-40...+130 °C	-40...+100 °C														
Maximum medium temperature	+285 °C	+185 °C	+125 °C														

DTS 1000010919 EN Version: | Status: RL (released | freigegeben | validé) printed: 13.12.2023

4. Materials

4.1. Bürkert resistApp

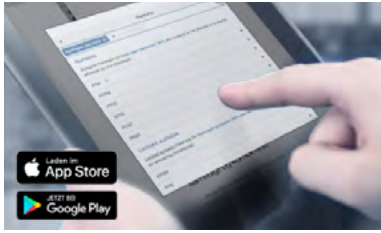

Bürkert resistApp – Chemical resistance chart

You want to ensure the reliability and durability of the materials in your individual application case? Verify your combination of media and materials on our website or in our resistApp.

[Start chemical resistance check](#)

4.2. Material specifications

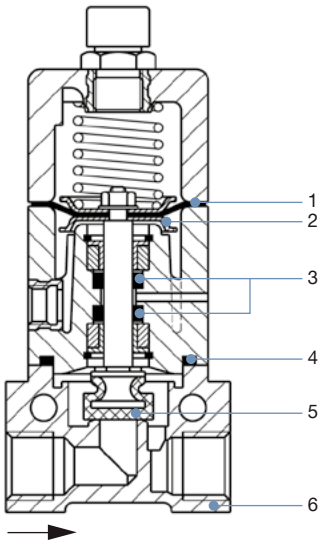

No.	Element	Material
1	Control diaphragm	FKM, PTFE
2	Spring plate	Stainless steel 1.4301
3	Lip seal	NBR, EPDM, FKM, PTFE
4	O-ring	NBR, EPDM, FKM
5	Seal	NBR, EPDM, FKM, PTFE
6	Body	Brass, stainless steel 1.4581

5. Dimensions

Note:

- Upper pilot air port only for CF B and CF I
- Dimensions in mm

DN 10/DN 12

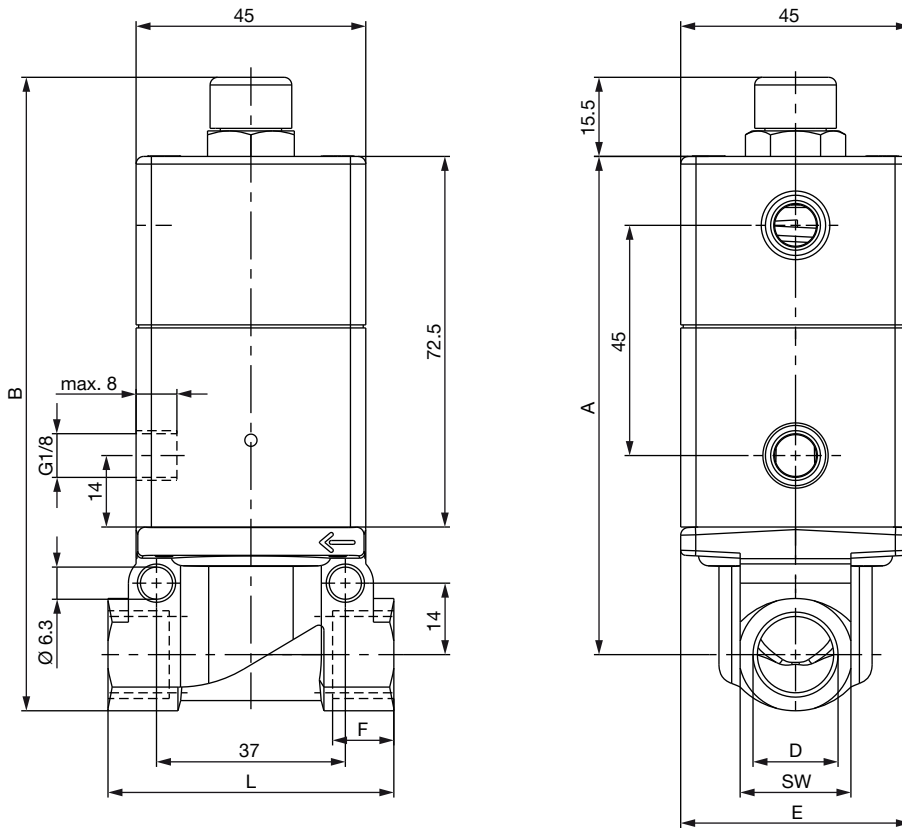

DN 20/DN 25

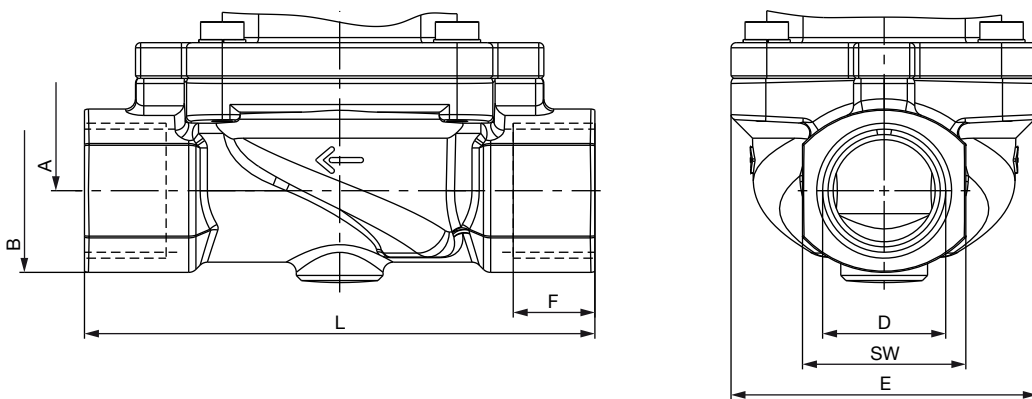

Nominal diameter	D	A	B	E	F	L	AF
10	G 3/8	97.5	124.0	45	12	56.0	22
12	G 1/2	96.5	127.5	40	14	74.5	27
20	G 3/4	109.5	141.0	60	16	100	32
25	G 1	114.0	150.0	70	18	115	41

6. Performance specifications

6.1. Pressure range

Nominal diameter [mm]	K _v value water [m ³ /h] ^{1.)}	Port connection	Operating pressure max.			Control pressure max. [bar] ^{2.)}	Weight [kg]
			CF A, normal spring [bar] ^{2.)}	CF A, reinforced spring [bar] ^{2.)}	CF B and CF I, normal spring [bar] ^{2.)}		
10	1.0	G 3/8	5.0	10	10	6	0.5
12	2.1	G 1/2	3.5	6	10	6	0.6
20	6.5	G 3/4	–	1.5	1.5	6	1.0
25	10.0	G 1	–	1	1	6	1.4

1.) Measurement at +20 °C, 1 bar at valve inlet and free discharge

2.) Pressure information: overpressure with respect to ambient pressure

6.2. Operating pressure/pilot pressure diagram

Control function B

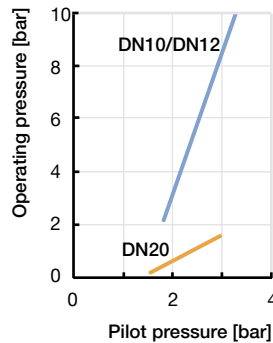

7. Ordering information

7.1. Bürkert eShop



Bürkert eShop – Easy ordering and quick delivery

You want to find your desired Bürkert product or spare part quickly and order directly? Our online shop is available for you 24/7. Sign up and enjoy all the benefits.

[Order online now](#)

7.2. Bürkert product filter



Bürkert product filter – Get quickly to the right product







































You want to select products comfortably based on your technical requirements? Use the Bürkert product filter and find suitable articles for your application quickly and easily.

[Try out our product filter](#)

7.3. Ordering chart

Note:

Valves with threaded connection

Control function	Port connection	Nominal diameter [mm]	K _v value water [m ³ /h] ^{1.)}	Operating pressure max. [bar] ^{2.)}	Pressure spring actuator	Seal material	Article no.		
Brass body									
A	G 3/8	10	1.0	5	Normal	EPDM	026059 		
						FKM	026257 		
						NBR	026287 		
				10	Reinforced	EPDM	027400 		
						FKM	026459 		
						NBR	027643 		
	PTFE/FKM	026457 							
		G 1/2	12	2.1	3.5	Normal	EPDM	027545 	
							FKM	026088 	
	NBR						027734 		
	6	Reinforced	EPDM	026079 					
			FKM	027926 					
			NBR	027991 					
	PTFE/EPDM	026200 							
		PTFE/FKM	028004 						
G 3/4	20	6.5	1.5	Reinforced	EPDM	028211 			
					FKM	028046 			
					NBR	028072 			
G 1	25	10.0	1	Reinforced	EPDM	029106 			
					FKM	028410 			
					NBR	028071 			
B	G 3/8	10	1.0	10	Normal	EPDM	026812 		
						FKM	027891 		
						NBR	026290 		
	G 1/2	12	2.1	10	Normal	EPDM	027988 		
						FKM	026715 		
						NBR	026298 		
	G 3/4	20	6.5	1.5	Normal	EPDM	028557 		
						FKM	027773 		
						NBR	027639 		
Stainless steel body									
A	G 1/2	10	1.0	10	Reinforced	EPDM	167814 		
						NBR	228680 		
	G 1/2	12	2.1	3.5	Normal	FKM	028011 		
						6	Reinforced	EPDM	028080 
								PTFE/FKM	027557 
FKM	028762 								
B	G 1/2	12	2.1	10	Normal	FKM	029007 		
						PTFE/FKM	027558 		
						PTFE/EPDM	028496 		

1.) Measurement at +20 °C, 1 bar at valve inlet and free discharge

2.) Pressure information: overpressure with respect to ambient pressure