



Read this document carefully before using this device. The guarantee will be expired by device damages if you don't attend to the directions in the user manual. Also we don't accept any compensations for personal injury, material damage or capital disadvantages.

## ENDA ET SERIES PID TEMPERATURE CONTROLLER

Thank you for choosing ENDA ET SERIES PID temperature controller.

- ▶ Selectable dual setpoint.
- ▶ Selectable thermocouple types.
- ▶ Automatic calculation of PID parameters (SELFTUNE).
- ⚠ **Selftune for automatic PID calculation or manually enter PID parameters if known.**
- ▶ Three different specifications can be assigned to digital input.
- ▶ Three different specifications can be assigned to F function key.
- ▶ Soft-Start feature.
- ▶ Selectable SSR control output.
- ▶ C/A2 Relay output programmable as secondary alarm or control output.
- ▶ A1 Relay output programmable as primary alarm or PID cooling output.
- ▶ Selectable heating/cooling control.
- ▶ Zero point input shift.
- ▶ In case of sensor failure, manually, periodical or auto-periodical control can be selected.
- ▶ RS485 ModBus protocol communication feature (optional).
- ▶ CE marked according to European Norms.

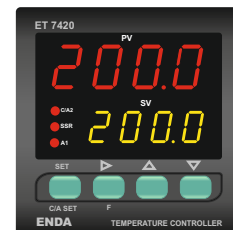

Order Code : ET <input type="text" value="4"/> <input type="text" value="2"/> <input type="text" value="0"/> - <input type="text" value="-"/> <input type="text" value="-"/> <input type="text" value=""/>		
1 - Size	2 - Supply Voltage	3 - Modbus
4420.....48x48x87mm 7420.....72x72x97mm 8420.....48x96x87mm 9420.....96x96x50mm	230.....230V AC LV.....10-30V DC / 8-24V AC	RS... Modbus (Specify at order)



Input Type		Temperature Range		Accuracy
		°C	°F	
PT100 Resistance thermometer	EN 60751	-199.9...600.0 °C	-199.9...999.9 °F	± 0,2% (of full scale) ± 1 digit
PT100 Resistance thermometer	EN 60751	-200...600 °C	-328....1112 °F	± 0,2% (of full scale) ± 1 digit
J (Fe-CuNi) Thermocouple	EN 60584	-30.0....600.0°C	-22.0....999.9 °F	± 0,5% (of full scale) ± 1 digit
J (Fe-CuNi) Thermocouple	EN 60584	-30....600°C	-22....1112 °F	± 0,5% (of full scale) ± 1 digit
K (NiCr-Ni) Thermocouple	EN 60584	-30.0...999.9°C	-22.0....999.9 °F	± 0,5% (of full scale) ± 1 digit
K (NiCr-Ni) Thermocouple	EN 60584	-30....1300°C	-22....2372 °F	± 0,5% (of full scale) ± 1 digit
L (Fe-CuNi) Thermocouple	DIN 43710	-30.0....600.0°C	-22.0....999.9 °F	± 0,5% (of full scale) ± 1 digit
L (Fe-CuNi) Thermocouple	DIN 43710	-30....600°C	-22....1112 °F	± 0,5% (of full scale) ± 1 digit
T (Cu-CuNi) Thermocouple	EN 60584	-30.0....400.0°C	-22.0....752.0 °F	± 0,5% (of full scale) ± 1 digit
T (Cu-CuNi) Thermocouple	EN 60584	-30....400°C	-22....752 °F	± 0,5% (of full scale) ± 1 digit
S (Pt10Rh-Pt) Thermocouple	EN 60584	-40...1700°C	-40....3092 °F	± 0,5% (of full scale) ± 1 digit
R (Pt13Rh-Pt) Thermocouple	EN 60584	-40...1700°C	-40....3092 °F	± 0,5% (of full scale) ± 1 digit
B (Pt30Rh-Pt9Rh) Thermocouple	EN 60584	200...1700°C	392....3092 °F	± 0,5% (of full scale) ± 1 digit

ENVIRONMENTAL CONDITIONS	
Ambient/storage temperature	0 ... +50°C/-25... +70°C (with no icing)
Max. Relative humidity	Relative humidity 80% for temperatures up to 31°C decreasing linearly to 50% relative humidity at 40°C.
Rated pollution degree	According to EN 60529 Front panel : IP65, Rear panel : IP20
Height	Max. 2000m

⚠ Do not use the device in locations subject to corrosive and flammable gases.

ELECTRICAL CHARACTERISTICS	
Supply	230V AC 50/60Hz ; 10-30V DC / 8-24V AC SMPS
Power consumption	Max. 5VA
Wiring	Power connector: 2.5mm <sup>2</sup> screw-terminal, Signal connector: 1,5mm <sup>2</sup> screw-terminal conenction.
Line resistance	Max. 100ohm
Data retention	EEPROM (minimum 10 years)
EMC	EN 61326-1: 2013
Safety requirements	EN 61010-1: 2010 (Pollution degree 2, overvoltage category II)

OUTPUTS	
C/A2 output	Relay : 250V AC, 8A (resistive load), Selectable as NO+NC Control or Alarm2 output.
A1 output	Relay : 250V AC, 8A (resistive load), NO (Selectable as Alarm1 or Cooling Control output).
SSR output	Max 20mA 24Volt
Life expectancy for relay	Mechanical 30. Mio; Electrical 100.000 operation. 250V AC, 8A (resistive load).

CONTROL	
Control type	Single set-point and alarm control
Control algorithm	On-Off / P, PI, PD, PID (selectable)
A/D converter	12 bit
Sampling time	100ms
Proportional band	Adjustable between 0% and 100%. If Pb=0.0%, On-Off control is selected.
Control period	Adjustable between 1 and 125 seconds
Hysteresis	Adjustable between 1 and 50°C/F
Output power	The ratio of power at a set point can be adjusted between 0% and 100%

HOUSING	
Housing type	Suitable for flush-panel mounting according to DIN 43 700.
Dimensions	ET4420 : G48XY48XD87MM ET7420 : G72XY72XD97MM ET8420 : G48XY96XD87MM ET9420 : G96XY96XD50MM
Weight	Approx. 400g after packing (250g for ET4420).
Enclosure material	Self extinguishing plastics.

⚠ While cleaning the device, solvents (thinner, gasoline, acid etc.) or corrosive materials must not be used.

up to date: 07.06.2023, modification reserved and can be change any time previous notice!

Entering from the "Programming Mode" to the "Running Mode" :  
If no key is pressed within 20 seconds during "Programming Mode", the data is stored automatically and the "Running Mode" is entered.

Alternatively, the same function occurs first pressing key is pressing "Programming Mode" is entered. Then keys are pressing together, data is recorded and "Running mode" is entered.

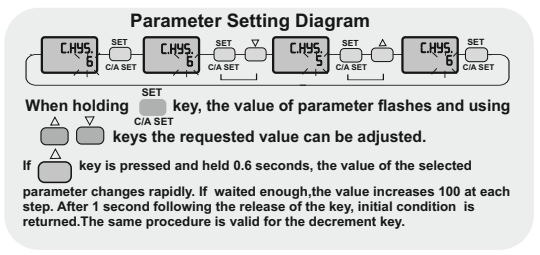
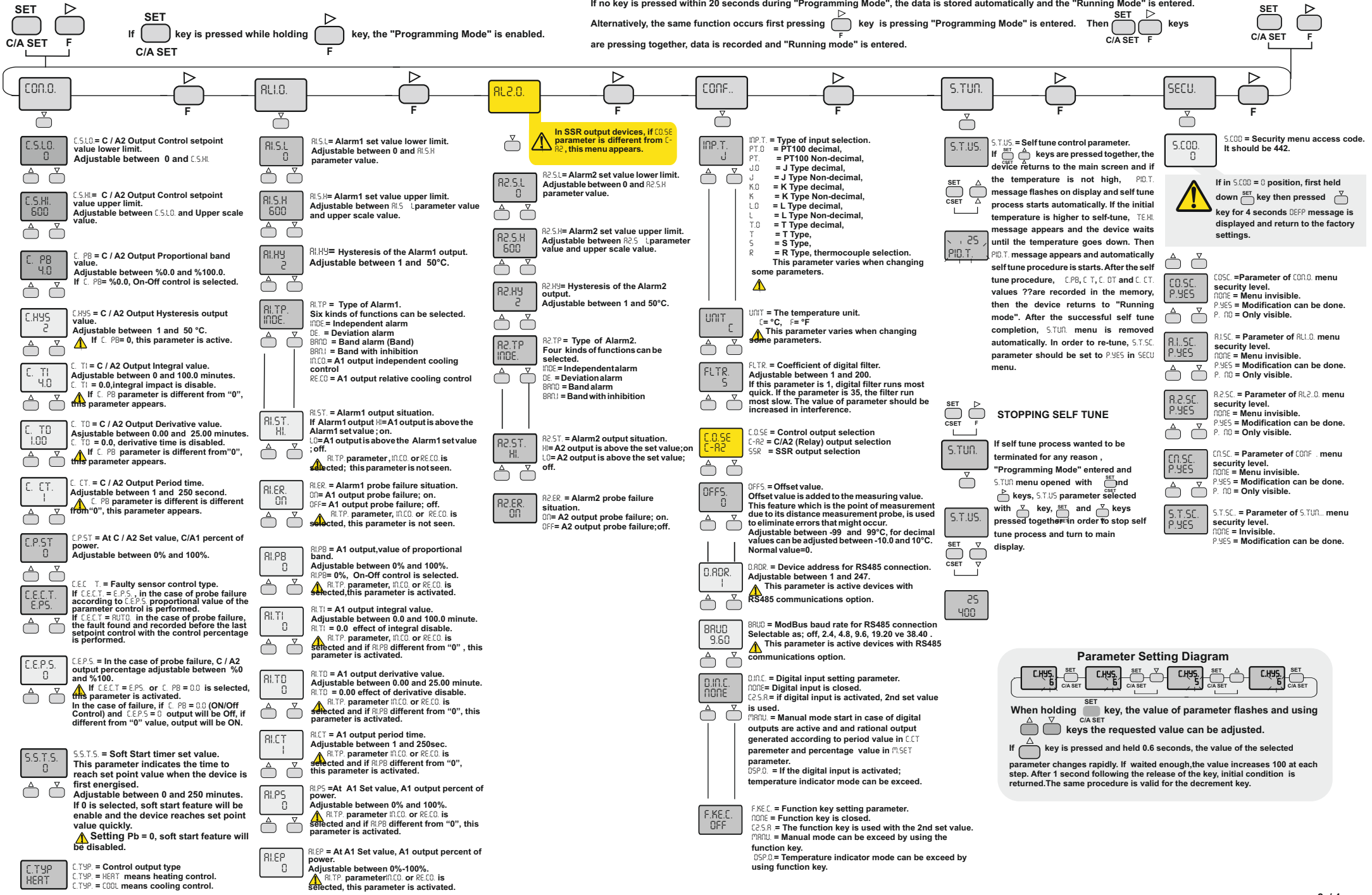

# CONNECTION DIAGRAM

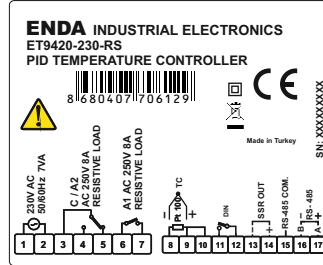
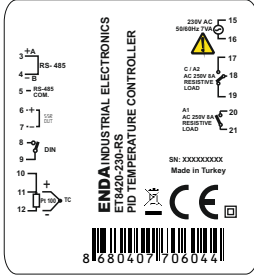
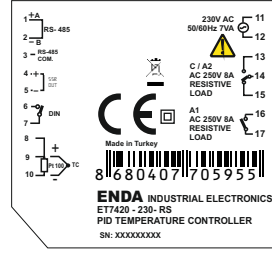
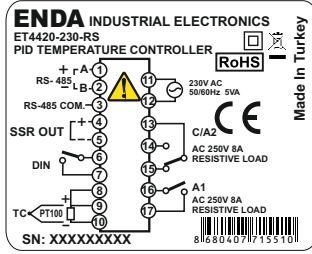
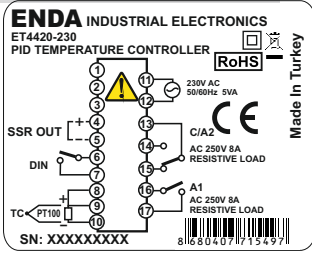

## NOTE :

### SUPPLY VOLTAGE

184-253V AC  
10-30V DC /  
8-24V AC  
50/60Hz 7VA

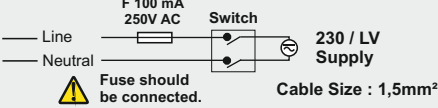
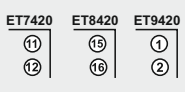

- Holding screw 0.4-0.5Nm
- Equipment is protected throughout by DOUBLE INSULATION.



Logic output of the instrument is not electrically insulated from the internal circuits. Therefore, when using a grounding thermocouple, do not connect the logic output terminals to the ground.

### SENSOR INPUT:

For J - K - T - S and R Thermocouples :  
Use the correct compensating cable.  
Do not make any supplement to cables. Connect the thermocouple cables to the right places at the input terminal.

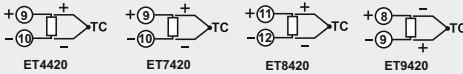

For resistance (PT100) Sensor :  
When using 2-wire PT100 sensor, as shown in the figures, make 8 and 9 terminals short circuit for ET4420, ET7420 and ET9420 devices, make 10 and 11 terminals short circuit for ET8420 devices.

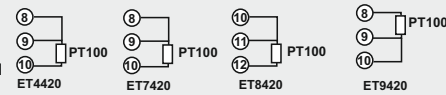

### Note :

- 1) Mains supply cords shall meet the requirements of IEC 60227 or IEC 60245.
- 2) In accordance with the safety regulations, the power supply switch shall bring the identification of the relevant instrument and it should be easily accessible by the operator.

## ALARM1 AND ALARM2 OUTPUT TYPES

### Independent Alarm

RI.TP = INDE

ASV min. = beginning of scale  
ASV max. = end of scale  
SV = CONT output set value

### Deviation Alarm

RI.TP = DE.

SV+ASV +300  
-300 (ASV min. = -300, ASV maks. = +300)  
ASV = Alarm output set value

### Band Alarm

RI.TP = BAN0

SV=CONT output set value ASV = AL1 output set value  
(ASV min. = 0, ASV max. = +300)

### Band Alarm With Inhibition

RI.TP = BAN.I

SV = Set point of CONT output  
ASV = Set point of AL1 output  
(ASV min. = 0, ASV max. = 300)

## SETTING UP ALARM CONTROL AND SETPOINT VALUES

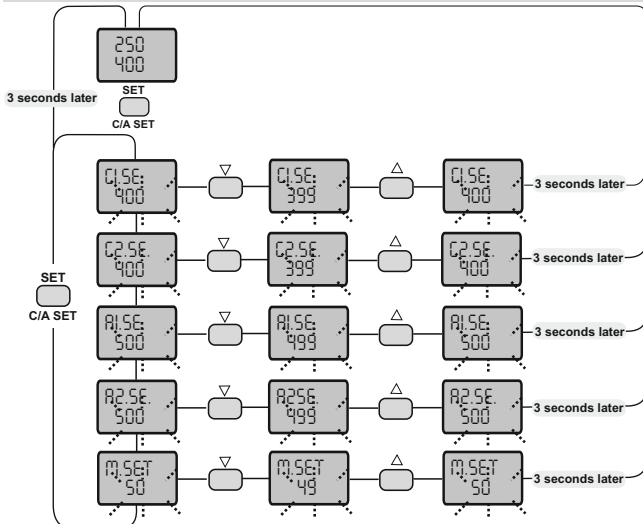

If one of the D1.A.C. or F.K.E.C. parameters are set to the C2.S.R. value, this parameter is seen.

If the C.O.S.E. parameter is set to SSR out, this parameter is seen.

If one of the D1.A.C. or F.K.E.C. parameters are set to the M.A.N.U. value and if C.P.B. is different from 0, this parameter is seen.

### ERROR MESSAGES

- P.F.F. 400 Temperature sensor is broken.
- 400 Temperature value is higher than the scale.
- 400 Temperature value is broken or over temperature.
- LOTE The temperature read on type B sensors is below 200°C.

## DIMENSIONS

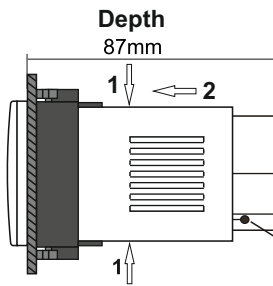
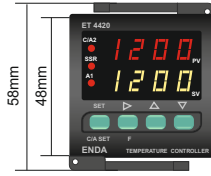

To removing the device from the panel :  
- Push both sides in direction 1 and move the device in direction 2

Connection Cables

Ambient temperature sensor

Flush mounting clamp  
Panel

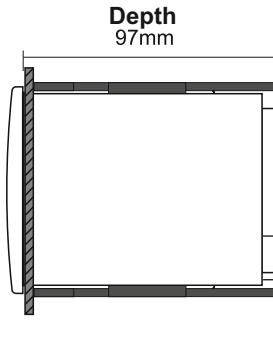
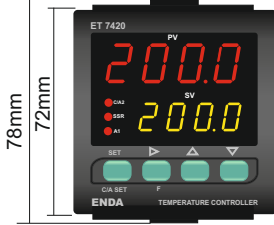
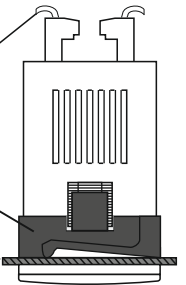

To removing the device from the panel :  
- Pull up the clamping kit in direction 1 and move the clamping kit in direction 2

Connection Cables

Ambient temperature sensor

Flush mounting clamp

Panel  
Gasket

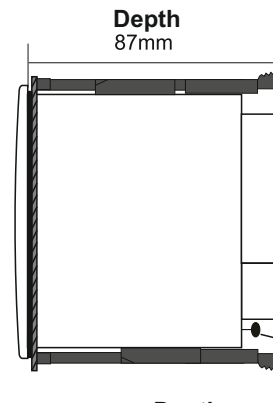
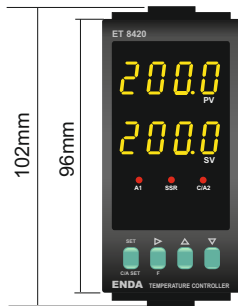
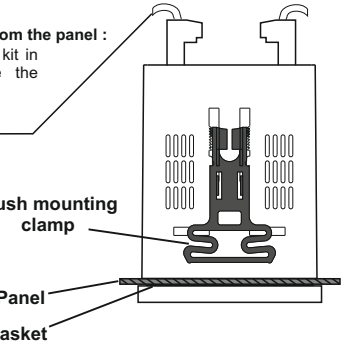

To removing the device from the panel :  
- Pull up the clamping kit in direction 1 and move the clamping kit in direction 2

Connection Cables

Ambient temperature sensor

Flush mounting clamp

Panel  
Gasket

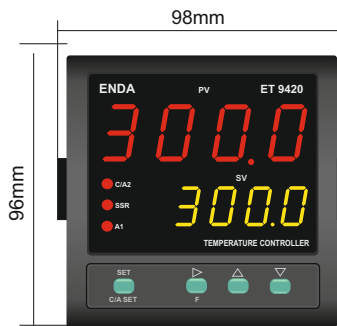
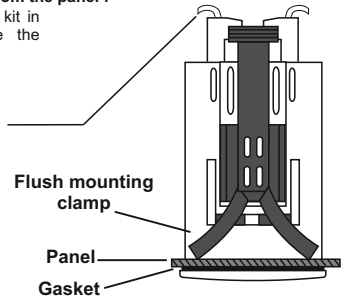

To removing the device from the panel :  
- Push the clamping kit in direction 1 sideways and move the clamping kit in direction 2

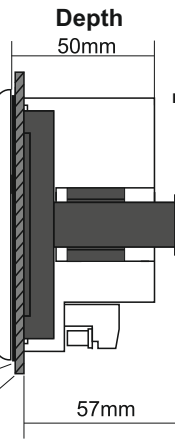

Flush mounting clamp

Gasket  
Panel



**ENDA ETx420 Series PID Temperature Controllers** are intended for installation in control panels. Make sure that the device is used only for intended purpose.

The shielding must be grounded on the instrument side. During an installation all of the cables that are connected to the device must be free of energy. Device must be protected against inadmissible humidity, vibrations, severe soiling and make sure that the operation temperature is not exceeded. All input and output lines that are not connected to the supply network must be laid out as shielded and twisted cables. These cables should not be close to the power cables or components. The installation and electrical connections must be carried on by a qualified staff and must be according to the relevant locally applicable regulations.

## PANEL CUT-OUT

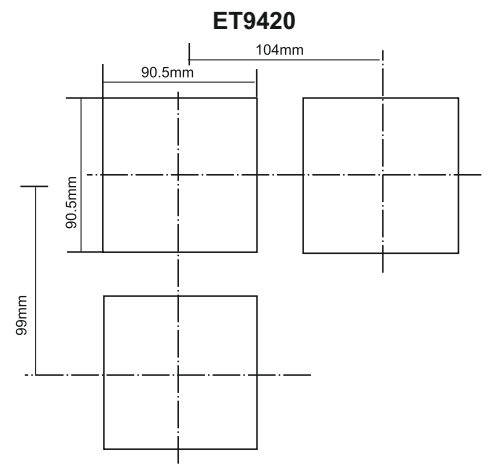
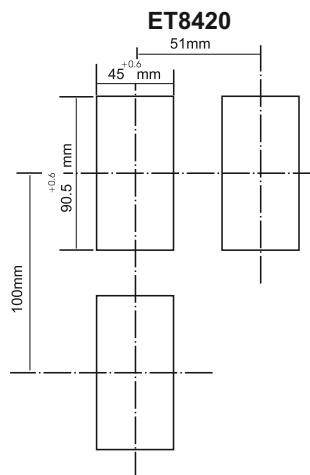
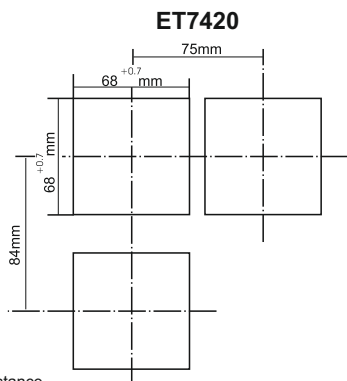
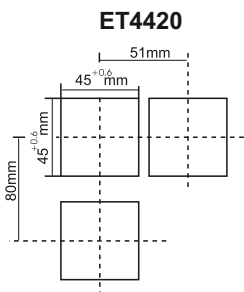

### Note :



- 1) While panel mounting, additional distance required for connection cables should be considered (except ET9420).
- 2) Panel thickness should be maximum 9mm for ET4420, 10mm for ET7420, 8mm for ET8420 and 6mm for ET9420.
- 3) If there is no free space at back side of the device, it would be difficult to remove it from the panel. Required minimum free space; ET4420 = 100mm, ET8420 = 90mm, ET9420 = 60mm.

# ENDA ET SERIES PID TEMPERATURE CONTROLLER MODBUS ADDRESS MAP

## 1.1 Memory Map for Holding Registers

	Parameter Number	Holding Register Addresses Desimal (Hex)	Data Type	Data Content	Read / Write Permission	Factory Defaults
<b>Control Output Parameters</b>	<b>H0</b>	0000d (0000h)	Word	Control output, temperature setpoint value	Read / Write	400
	<b>H1</b>	0001d (0001h)	Word	Control output, 2nd temperature setpoint value	Read / Write	400
	<b>H2</b>	0002d (0002h)	Word	Control output, minimum setpoint value	Read / Write	0
	<b>H3</b>	0003d (0003h)	Word	Control output, maximum setpoint value	Read / Write	600
	<b>H4</b>	0004d (0004h)	Word	Control output, proportional band setpoint value (Adjustable between %0.0 and %100.0)	Read / Write	4
	<b>H5</b>	0005d (0005h)	Word	Control output, hysteresis value (Adjustable between 1 and 50 °C or °F)	Read / Write	2
	<b>H6</b>	0006d (0006h)	Word	Control output, integral time (Adjustable between 0.1 and 100.0 minute)	Read / Write	40
	<b>H7</b>	0007d (0007h)	Word	Control output, derivative time (Adjustable between 0.01 and 10.00 minute)	Read / Write	100
	<b>H8</b>	0008d (0008h)	Word	Control output, time period setpoint value (Adjustable between 1 and 125 second)	Read / Write	20
	<b>H9</b>	0009d (0009h)	Word	Control output, set value power ratio (Adjustable between %0 and %100)	Read / Write	0
	<b>H10</b>	0010d (000Ah)	Word	Control output, set value power ratio in case of sensor failure (Adjustable between %0 and %100)	Read / Write	0
<b>A1 Output Parameters</b>	<b>H11</b>	0011d (000Bh)	Word	Control output, soft start value	Read / Write	0
	<b>H12</b>	0012d (000Ch)	Word	Alarm1 output temperature setpoint value	Read / Write	500
	<b>H13</b>	0013d (000Dh)	Word	Alarm1 output minimum setpoint value limit	Read / Write	0
	<b>H14</b>	0014d (000Eh)	Word	Alarm1 output maximum setpoint value limit	Read / Write	600
	<b>H15</b>	0015d (000Fh)	Word	Alarm1 output proportional band set value (Adjustable between %0.0 and %100.0)	Read / Write	0
	<b>H16</b>	0016d (0010h)	Word	Alarm1 output hysteresis value (Adjustable between 1 and 50 °C or °F)	Read / Write	2
	<b>H17</b>	0017d (0011h)	Word	Alarm1 output, integral time (Adjustable between 0.1 and 100.0 minute)	Read / Write	0
	<b>H18</b>	0018d (0012h)	Word	Alarm1 output, derivative time (Adjustable between 0.01 and 10.00 minute)	Read / Write	0
	<b>H19</b>	0019d (0013h)	Word	Alarm1 output, time period setpoint value (Adjustable between 1 and 125 second)	Read / Write	20
	<b>H20</b>	0020d (0014h)	Word	Alarm1 output, set value power ratio (Adjustable between %0 and %100)	Read / Write	0
	<b>H21</b>	0021d (0015h)	Word	Alarm1 output, set value power ratio in case of sensor failure (Adjustable between %0 and %100)	Read / Write	0
	<b>H22</b>	0022d (0016h)	Word	Alarm1 output type selection (Values can be given from 0 to 4) (0 = Independent alarm, 1 = Deviation alarm, 2 = Band alarm, 3 = Active alarm after in band time, 4 = Alarm1 output, cooling control selection )	Read / Write	0
<b>A2 Output Parameters</b>	<b>H23</b>	0023d (0017h)	Word	Alarm2 output, temperature setpoint value	Read / Write	500
	<b>H24</b>	0024d (0018h)	Word	Alarm2 output minimum setpoint value limit	Read / Write	0
	<b>H25</b>	0025d (0019h)	Word	Alarm2 output maximum setpoint value limit	Read / Write	600
	<b>H26</b>	0026d (001Ah)	Word	Alarm2 output, hysteresis value (Adjustable between 1 and 50 °C or °F)	Read / Write	2
	<b>H27</b>	0027d (001Bh)	Word	Alarm2 output type selection (Values can be given from 0 to 3) (0 = Independent alarm, 1 = Deviation alarm, 2 = Band alarm, 3 = Active alarm after in band time)	Read / Write	0
<b>Configuration Parameters</b>	<b>H28</b>	0028d (001Ch)	Word	Input selection number (0 = PT100 Decimal, 1 = Pt100 Non-decimal, 2 = J Decimal, 3 = J Non-decimal, 4 = K Decimal, 5 = K Non-decimal, 6 = L Decimal, 7 = L Non-decimal, 8 = T Decimal, 9 = T Non-decimal, 10 = S Non-decimal, 11 = R Non-decimal.	Read / Write	5
	<b>H29</b>	0029d (001Dh)	Word	ModBus device address (Adjustable between 1 and 247)	Read / Write	1
	<b>H30</b>	0030d (001Eh)	Word	Modbus communication speed (Baudrate) (0 = Modbus cancel, 1 = 2400 bps, 2 = 4800 bps, 3 = 9600 bps, 4 = 19200 bps, 5 = 38400 bps)	Read / Write	3
	<b>H31</b>	0031d (001Fh)	Word	Digital filter coefficient (Adjustable between 1 and 200, 1 = filter is disable)	Read / Write	10
	<b>H32</b>	0032d (0020h)	Word	Control output, selection value (0 = C/A2 Control output selection, 1 = SSR Output )	Read / Write	0
	<b>H33</b>	0033d (0021h)	Word	Reserved	Read / Write	XX
	<b>H34</b>	0034d (0022h)	Word	Reserved	Read / Write	XX
	<b>H35</b>	0035d (0023h)	Word	Offset value	Read / Write	0
	<b>H36</b>	0036d (0024h)	Word	Function control parameter. ( 23040d ( 5A00h ) self tune stops when this value is entered ) ( 23041d ( 5A01h ) self tune starts when this value is entered ) ( 23042d ( 5A02h ) returns to factory defaults when this value is entered )	Read / Write	0
	<b>H37</b>	0037d (0025h)	Word	Reserved	Read / Write	XX
	<b>H38</b>	0038d (0026h)	Word	Reserved	Read / Write	XX
	<b>H39</b>	0039d (0027h)	Word	Manual control output percentage (Adjustable between %0 and %100)	Read / Write	50

# ENDA ET SERIES PID TEMPERATURE CONTROLLER MODBUS ADDRESS MAP

## 1.1 Memory Map for Holding Registers (continue)

Parameter Number	Holding Register Addresses	Data Type	Data Content	Read / Write Permission	Factory Defaults	
	Desimal (Hex)					
<b>Configuration Parameters</b>	<b>H40</b>	0040d (0028h)	Word	Digital input control parameter ( 0 = Digital input off, 1 = 2nd set value is selected with digital input, 2 = Manual mode is entered via digital input, 3 = Digital input is passed to display mode	Read / Write	0
	<b>H41</b>	0041d (0029h)	Word	Function key control parameter ( 0 = Function key off, 1 = 2nd Set value is selected with function key, 2 = Manual mode is entered via function key, 3 = With the function key display mode is entered)	Read / Write	0
	<b>H42</b>	0042d (008Ah)	Word	Reserved	Read / Write	XX
	<b>H43</b>	0043d (002Bh)	Word	Reserved	Read / Write	XX
	<b>H44</b>	0044d (002Ch)	Word	Reserved	Read / Write	XX
	<b>H45</b>	0045d (002Dh)	Word	Reserved	Read / Write	XX
	<b>H46</b>	0046d (002Eh)	Word	Reserved	Read / Write	XX
	<b>H47</b>	0047d (002Fh)	Word	Reserved	Read / Write	XX
	<b>H48</b>	0048d (0030h)	Word	Control output menu, security parameter ( 0 = Menu invisible, 1 = Menu programmable, 2 = Menu only visible )	Read / Write	1
	<b>H49</b>	0049d (0031h)	Word	Alarm1 output menu security parameter ( 0 = Menu invisible, 1 = Menu programmable, 2 = Menu only visible )	Read / Write	1
	<b>H50</b>	0050d (0032h)	Word	Alarm2 output menu, security parameter ( 0 = Menu invisible, 1 = Menu programmable, 2 = Menu only visible )	Read / Write	1
	<b>H51</b>	0051d (0033h)	Word	Configuration menu, security parameter ( 0 = Menu invisible, 1 = Menu programmable, 2 = Menu only visible )	Read / Write	1
	<b>H52</b>	0052d (0034h)	Word	Self tune menu, security parameter ( 0 = Menu invisible, 1 = Self tune can be done)	Read / Write	1

## 1.2 Memory Map for Coils

Parameter Number	Coil Addresses	Data Type	Data Content	Read / Write Permission	Factory Defaults
<b>C0</b>	(0000)h	Bit	Alarm2 Status (0 = Active Low ,1 =Active High)	Read / Write	1
<b>C1</b>	(0001)h	Bit	Alarm2 output position in case of Prob failure (0 = Off , 1 = On )	Read / Write	0
<b>C2</b>	(0002)h	Bit	Alarm1 Status (0 = Active Low ,1 =Active High)	Read / Write	1
<b>C3</b>	(0003)h	Bit	Alarm1 output position in case of Prob failure (0 = Off , 1 = On )	Read / Write	0
<b>C4</b>	(0004)h	Bit	Control output configuration ( 0 = Heat ; 1 = Cool )	Read / Write	0
<b>C5</b>	(0005)h	Bit	Temperature unit (0 = °C ; 1 = °F)	Read / Write	0
<b>C6</b>	(0006)h	Bit	Control outputs active (0 = Control outputs active, 1 = Only display mode)	Read / Write	0
<b>C7</b>	(0007)h	Bit	Controlling according to 2nd temperature setpoint (If C7 = 0 is H0, if C7 = 1 is H1)	Read / Write	0
<b>C8</b>	(0008)h	Bit	Auto/Manual selection (0 = Automatic "Running mode", 1 = Manual "Running mode". In this mode, output generated according to H39 parameter.)	Read / Write	0
<b>C9</b>	(0009)h	Bit	Control format in case of probe failure (0 = H10 proportional control according to percentage value, 1 = Error found before the setpoint control is done with the value of the proportional control)	Read / Write	0

## 1.3 Memory Map for Input Registers

Parameter Number	Input Register Addresses	Data Type	Data Content	Read / Write Permission
<b>I0</b>	0000d (0000h)	Word	Measured temperature	Read Only
<b>I1</b>	0001d (0001h)	Word	Percentage of analog output	Read Only
<b>I2</b>	0002d (0002h)	Word	Measurement error codes 0 = No error, 1 = Sensor disconnected or broken, 2 = Lower scale error, 3 = Upper scale error, 4 = PT100 short circuit or temperature too low, 5 = Wrong input selection	Read Only
<b>I3</b>	0003d (0003h)	Word	Self tune condition codes 0 = No error, 1 = Initial temperature is higher than 60% setpoint value, 2 = Calculating PID parameters, 3 = Calculating power set parameters	Read Only
<b>I4</b>	0004d (0004h)	Word	Current (active) temperature setpoint.	Read Only
<b>I5</b>	0005d (0005h)	Word	Reserved	Read Only
<b>I6</b>	0006d (0006h)	Word	Current (active) decimal point value (0 = No decimal point, 1 = 0.0 Decimal point is tenths)	Read Only

## 1.4 Memory Map for Software Revision Input Registers

Software Revision	61472d (F020h)	14 Word	Software name and update is read in ASCII format and as 14 word. Sample : ET4420-01 03 Dec 2013. Memory Formats : Word Word Word Word Word Word Word Word Word Word Word Word Word Word Word 1 2 3 4 5 6 7 8 9 10 11 12 13 14 <b>TE44020-1 30DCE210.3</b>	Read Only
<b>NOTE :</b> To view each word correctly by changing the byte sequences should be displayed as ASCII TEXT				

# ENDA ET SERIES PID TEMPERATURE CONTROLLER MODBUS ADDRESS MAP

## 1.5 Memory Map for Discrete input

Parametre Numarasi	Discrete Input Addresses	Data Type	Data Content	Read / Write Permission
D0	(0000)h	Bit	C/A2 Control output status (0 = OFF ,1 = ON)	Read Only
D1	(0001)h	Bit	A1 Output status (0 = OFF , 1 = ON )	Read Only
D2	(0002)h	Bit	SSR Output status (0 = OFF ,1 = ON)	Read Only
D3	(0003)h	Bit	Digital input status (0 = OFF ,1 = ON)	Read Only

## 2. MODBUS ERROR MESSAGES

Modbus protocol has two types error, communication error and operating error. Reason of the communication error is data corruption in transmission. Parity and CRC control should be done to prevent communication error. Receiver side checks parity and CRC of the data. If they are wrong, the message will be ignored. If format of the data is true but function doesn't perform for any reason, operating error occurs. Slave realizes error and sends error message. Most significant bit of function is changed '1' to indicate error in error message by slave. Error code is sent in data section. Master realizes error type via this message.

### ModBus Error Codes

Error Code	Name	Meaning
01	ILLEGAL FUNCTION	The function code received in the query is not an allowable action for the slave. If a Poll Program Complete command was issued, this code indicates that no program function preceded it.
02	ILLEGAL DATA ADDRESS	The data address received in the query is not an allowable address for the slave.
03	ILLEGAL DATA VALUE	A value contained in the query data field is not an allowable value for the slave.

Message example;

Structure of command message (Byte Format)

Device Address		(0A)h
Function Code		(01)h
Beginning address of coils.	MSB	(04)h
	LSB	(A1)h
Number of coils (N)	MSB	(00)h
	LSB	(01)h
CRC DATA	LSB	(AC)h
	MSB	(63)h

Structure of response message (Byte Format)

Device Address		(0A)h
Function Code		(81)h
Error Code		(02)h
CRC DATA	LSB	(B0)h
	MSB	(53)h

As you see in command message, coil information of (4A1)h = 1185 is required but there isn't any coil with 1185 address. Therefore error code with number (02) (Illegal Data Address) sends.

