

Datos OMNIMATE - Transformador de conectores RJ45 RJ45G1 R12D 3.2E4YG/YG RL

Weidmüller Interface GmbH & Co. KG
Klingenbergstraße 16
D-32758 Detmold
Germany
Fon: +49 5231 14-0
Fax: +49 5231 14-292083
www.weidmueller.com

Imagen de producto



Conectores hembra de transmisores RJ45 (magnéticos) para aplicaciones de gigabit (1000 base-T) con compensación integrada contrarrestan activamente acoplamientos inductivos y capacitivos y ahorran espacio en el PCB.

- Procedimientos de soldadura THT o THR
- Amplia gama de diferentes tipos de diseño, también con LED integrados y lengüetas de contacto de apantallado
- Embalaje en bandeja (TY) o en rollo (embalaje en cinta, RL)
- Rango de temperaturas ampliado de -40 °C a +85 °C
- Capa de oro reforzada para protección mejorada contra la corrosión
- Velocidades de transmisión de hasta 1 Gbit/s

Datos generales para pedido

Tipo	RJ45G1 R12D 3.2E4YG/YG RL
Código	2036510000
Versión	Conector para placa c.i., Transformador de conectores RJ45, 1000 Mbps , Conexión por soldadura THT/THR, 90°, Opción de bloqueo: inferior, Anilla de apantallado: 6 tabs, 30-80 µ" Ni / 30- µ" Au , LED: Sí, Verde/amarillo, Verde/amarillo, Número de polos: 8, Tape
GTIN (EAN)	4050118408409
U.E.	180 Pieza
Embalaje	Tape

Datos OMNIMATE - Transformador de conectores RJ45 RJ45G1 R12D 3.2E4YG/YG RL

Weidmüller Interface GmbH & Co. KG
Klingenbergstraße 16
D-32758 Detmold
Germany
Fon: +49 5231 14-0
Fax: +49 5231 14-292083
www.weidmueller.com

Datos técnicos

Dimensiones y pesos

Anchura	31,2 mm	Anchura (pulgadas)	1,228 inch
Altura	16,9 mm	Altura (pulgadas)	0,665 inch
Altura construcción baja	13,6 mm	Profundidad	21,5 mm
Profundidad (pulgadas)	0,846 inch	Peso neto	7,675 g

Temperaturas

Temperatura de almacenamiento, max.	85 °C	Temperatura de almacenamiento, min.	-40 °C
Temperatura de servicio, max.	85 °C	Temperatura de servicio, min.	-40 °C

Conformidad medioambiental del producto

REACH SVHC	Lead 7439-92-1
------------	----------------

Especificaciones del sistema

Angulo de salida	90°	Anilla de apantallado	6 tabs
Apantallamiento	Sí	Ciclos de enchufado	750
Color de LED derecho	Verde/amarillo	Color de LED izquierdo	Verde/amarillo
Dimensiones del pin de soldadura	0,40 x 0,30 mm, Pines de LED = 0,50 x 0,50 mm	Diámetro de la perforación (D)	0,9 mm
Familia del producto	Datos OMNIMATE - Transformador de conectores RJ45	LED	Sí
Longitud del terminal de soldadura (l)	3,2 mm	Material del apantallamiento	Latón
Modo de conexión	10 conductores	Montaje sobre placas c.i.	Conexión por soldadura THT/THR
Número de polos	8	Número de terminales de soldadura por polo	1
Opción de bloqueo	inferior	Paso en mm (P)	1,27 mm
Paso en pulgadas (P)	0,05 inch	Superficie de apantallado	niquelado
Tipo de conexión	Conector hembra	Tipo de protección	IP20
Tolerancia de diámetro de la perforación (D)	± 0,1 mm	Velocidad de transmisión	1000 Mbps

Propiedades eléctricas

Intensidad nominal	1,5 A	Resistencia a tensiones eléctricas, contacto/apantallado	1500 V DC
Resistencia a tensiones eléctricas, contacto/contacto	≥ 1000 V DC	Resistencia de aislamiento	> 500 MΩ
Tensión nominal	125 V		

Datos del material

Materiales aislantes	PA 9T	Color	negro
Carta de colores (similar)	RAL 9011	Grupo de materiales aislantes	II
CTI	≥ 500	Resistencia de aislamiento	> 500 MΩ
Moisture Level (MSL)	1	Grado inflamabilidad según UL 94	V-0
Material del contacto	Fósforo, bronce	Superficie de contacto	Oro sobre níquel
Estructura de capas del contacto del conector	30-80 μ" Ni / 30-μ" Au	Temperatura de almacenamiento, min.	-40 °C
Temperatura de almacenamiento, max.	85 °C	Temperatura de servicio, min.	-40 °C
Temperatura de servicio, max.	85 °C		

Hoja técnica

**Datos OMNIMATE - Transformador de conectores
RJ45
RJ45G1 R12D 3.2E4YG/YG RL**

Weidmüller Interface GmbH & Co. KG
Klingenbergstraße 16
D-32758 Detmold
Germany
Fon: +49 5231 14-0
Fax: +49 5231 14-292083
www.weidmueller.com

Datos técnicos

Embalaje

Embalaje	Tape	Longitud de VPE	0 m
Anchura VPE	0 m	Altura de VPE	0 m
Diámetro de bobina de cinta \varnothing (A)	330 mm	Resistencia superficial	$R_s = 10^9 - 10^{12} \Omega$

Clasificaciones

ETIM 6.0	EC002637	eClass 6.2	27-25-05-04
eClass 9.0	27-44-04-02	eClass 9.1	27-44-04-02

Homologaciones en línea

Homologaciones



ROHS Conformidad

Descargas

Datos de ingeniería	STEP
Documentación del usuario	MAN IE GUIDE DE MAN IE GUIDE EN
Folleto/catálogo	MB FREECONTACT EN FL FIELDWIRING EN PI PROFINET CABLING EN
Notificación de cambio de producto	PCN PCN

**Datos OMNIMATE - Transformador de conectores
RJ45
RJ45G1 R12D 3.2E4YG/YG RL**

Weidmüller Interface GmbH & Co. KG
Klingenbergstraße 16
D-32758 Detmold
Germany
Fon: +49 5231 14-0
Fax: +49 5231 14-292083
www.weidmueller.com

Dibujos

Dibujo acotado

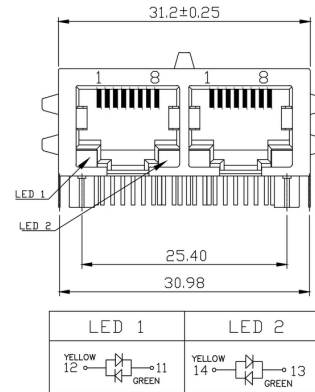

Dibujo acotado

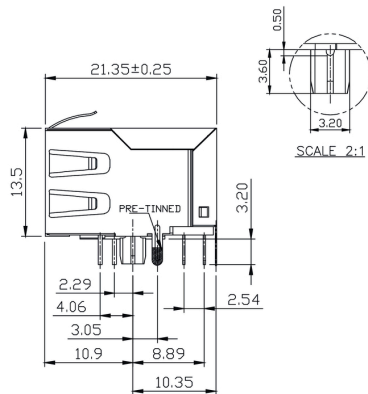

Diseño de la placa de circuito impreso

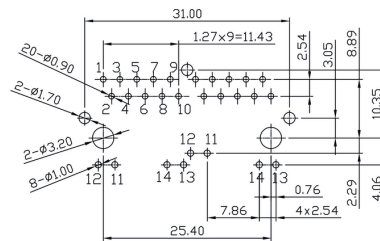

Esquema de conexiones

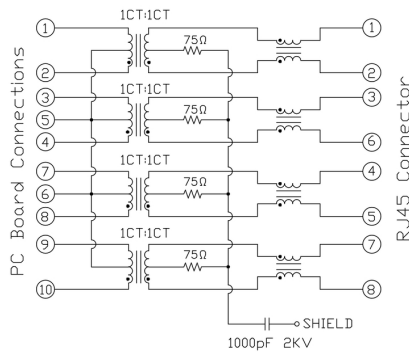

Datos OMNIMATE - Transformador de conectores RJ45 RJ45G1 R12D 3.2E4YG/YG RL

Weidmüller Interface GmbH & Co. KG
Klingenbergstraße 16
D-32758 Detmold
Germany
Fon: +49 5231 14-0
Fax: +49 5231 14-292083
www.weidmueller.com

Dibujos

Gráfico

Characteristics

Inductance	350 µH min. @ 100 kHz, 100 mV, 8 mA DC Bias
Leakage Inductance	0.3 µH max. @ 100 kHz, 100 mV
Insertion Loss	1.1 dB max. @ (1 - 100) MHz
Return Loss	18 dB min. @ (1 - 30) MHz 16 dB min. @ (30 - 60) MHz 12 dB min. @ (60 - 80) MHz
Cross Talk	30 dB min. @ (1 - 100) MHz
Common Mode Rejection	30 dB min. @ (1 - 100) MHz

Códigos de tipo

Code	Parameter	Value	Description
RJ45	Connector Type	RJ45	Standard RJ45 connector
G1	Performance Category	G1	Category 5, 10/100/1000 Mbit
R	Assembly on PCB	R	Through Hole Reflow - THR
U	Direction, latch style	U	Horizontal (90°, side entry), latch up
3.2	Solder Pin length	3.2	3.2 mm
E	EMI tabs (ground fingers)	E	E = with EMI tabs
4	Contact surface thickness	4	1 = 3µ", 2 = 6µ", 3 = 15µ", 4 = 30µ", 5 = 50µ"
GY/GY	LED	GY/GY	Green-Yellow/Green-Yellow
TY	Packaging	TY	Tray in box (manual assembly)
		RL	Tape on Reel (automated assembly)
		Y/G	Yellow/Green
		G/Y	Green/Yellow (standard)
		O/G	Orange/Green
		R/O	Red/Orange
		N	without LED
		D	SMD
		V	Vertical (180°, top entry), latch down
		Y	Diagonal (45°), latch up
		1	1 Port
		12; 14; ...	multi ports side by side, Multiport
		2; 4; ...	multi ports about each other, Multilevel
		S	Surface Mount Technology - SMT
		T	Through Hole Technology - THT
		C5	Category 5
		C6	Category 6
		C6A	Category 6A
		C5e	Category 5e
		M	10/100 Mbit
		G1	10/100/1000 Mbit
		G10	10 Gbit
		U	Unshielded
		MP	10/100 Mbit with POE
		MP+	10/100 Mbit with POE+

Recommended wave soldering profiles

Weidmüller Interface GmbH & Co. KG
 Klingenbergstraße 16
 D-32758 Detmold
 Germany
 Fon: +49 5231 14-0
 Fax: +49 5231 14-292083
 www.weidmueller.com

Single Wave:



Double Wave:



Wave soldering profiles

Wired connection elements should be processed in accordance with the DIN EN 61760-1 standard. We have included two recommendations for practical wave soldering profiles, with which Weidmüller PCB terminals and connectors are qualified.

When choosing a suitable profile for your application, the following factors also need to be considered:

- PCB thickness
- Proportion of Cu in the layers
- Single/double-sided assembly
- Product range
- Heating and cooling rates

The single and double wave profiles each indicate the recommended operating range, including the maximum soldering temperature of 260°C. In practice, the maximum soldering temperature is quite often well below the above maximum profile.

Recommended reflow soldering profile

Weidmüller Interface GmbH & Co. KG
 Klingenbergstraße 16
 D-32758 Detmold
 Germany
 Fon: +49 5231 14-0
 Fax: +49 5231 14-292083
 www.weidmueller.com



Reflow soldering profile

The perfect soldering profile for SMT Surface Mount Technology is one the most exiting question in SMT production. But there are more than one correct answer: The diagram of temperature-on-time is related to processing features of solder paste and to maximum load of components.

We have to consider the following parameters:

- Time for pre heating
- Maximum temperature
- Time above melting point
- Time for cooling
- Maximum heating rate
- Maximum cooling rate

We recommend a typical solder profile with associated process limits. With preheating components and board are prepared smoothly for the solder phase. Heating rate is typically $\leq +3\text{K/s}$. In parallel the solder paste is ‚activated‘. The time above melting point of 217°C the paste gets liquid and components and boards begin to connect. The maximum temperature of 245°C to 254°C should stay between 10 and 40 seconds. In the cooling phase at $\geq -6\text{K/s}$ solder is cured. Board and components cool down while avoiding cold cracks.