

Datos OMNIMATE - Transformador de conectores RJ45 RJ45M R12D 3.2N4G/Y RL

Weidmüller Interface GmbH & Co. KG
Klingenbergstraße 16
D-32758 Detmold
Germany
Fon: +49 5231 14-0
Fax: +49 5231 14-292083
www.weidmueller.com



Conectores hembra de transmisores RJ45 (magnéticos) para aplicaciones de gigabit (1000 base-T) con compensación integrada contrarrestan activamente acoplamientos inductivos y capacitivos y ahorran espacio en el PCB.

- Procedimientos de soldadura THT o THR
- Amplia gama de diferentes tipos de diseño, también con LED integrados y lengüetas de contacto de apantallado
- Embalaje en bandeja (TY) o en rollo (embalaje en cinta, RL)
- Rango de temperaturas ampliado de -40 °C a $+85\text{ °C}$
- Capa de oro reforzada para protección mejorada contra la corrosión
- Velocidades de transmisión de hasta 1 Gbit/s

Datos generales para pedido

Tipo	RJ45M R12D 3.2N4G/Y RL
Código	255190000
Versión	Conector para placa c.i., Transformador de conectores RJ45, 10/100 MBit/s , Conexión por soldadura THT/THR, 90°, Opción de bloqueo: inferior, Anilla de apantallado: ninguno, 30-80 μm Ni / 30- μm Au , LED: Sí, verde, amarillo, Número de polos: 8, Tape
GTIN (EAN)	4050118562187
U.E.	200 Pieza
Embalaje	Tape

Datos OMNIMATE - Transformador de conectores RJ45 RJ45M R12D 3.2N4G/Y RL

Weidmüller Interface GmbH & Co. KG
Klingenbergstraße 16
D-32758 Detmold
Germany
Fon: +49 5231 14-0
Fax: +49 5231 14-292083
www.weidmueller.com

Datos técnicos

Dimensiones y pesos

Anchura	31,2 mm	Anchura (pulgadas)	1,228 inch
Altura	16,7 mm	Altura (pulgadas)	0,657 inch
Altura construcción baja	13,5 mm	Profundidad	21,35 mm
Profundidad (pulgadas)	0,841 inch	Peso neto	7,07 g

Temperaturas

Temperatura de almacenamiento, max.	85 °C	Temperatura de almacenamiento, min.	-40 °C
Temperatura de servicio, max.	85 °C	Temperatura de servicio, min.	-40 °C

Conformidad medioambiental del producto

REACH SVHC	Lead 7439-92-1
------------	----------------

Especificaciones del sistema

Angulo de salida	90°	Anilla de apantallado	ninguno
Apantallamiento	Sí	Ciclos de enchufado	750
Color de LED derecho	amarillo	Color de LED izquierdo	verde
Diámetro de la perforación (D)	0,9 mm	Familia del producto	Datos OMNIMATE - Transformador de conectores RJ45
LED	Sí	Material del apantallamiento	Latón
Montaje sobre placas c.i.	Conexión por soldadura THT/THR	Número de polos	8
Número de terminales de soldadura por polo	1	Opción de bloqueo	inferior
Paso en mm (P)	1,27 mm	Paso en pulgadas (P)	0,05 inch
Superficie de apantallado	niquelado	Tipo de conexión	Conector hembra
Tipo de protección	IP20	Tolerancia de diámetro de la perforación (D)	± 0,1 mm
Velocidad de transmisión	10/100 MBit/s		

Propiedades eléctricas

Intensidad nominal	1,5 A	Resistencia a tensiones eléctricas, contacto/apantallado	1500 V DC
Resistencia a tensiones eléctricas, contacto/contacto	≥ 1000 V DC	Resistencia de aislamiento	> 500 MΩ
Tensión nominal	125 V AC		

Datos del material

Materiales aislantes	PA 9T	Color	negro
Carta de colores (similar)	RAL 9011	Grupo de materiales aislantes	II
CTI	≥ 500	Resistencia de aislamiento	> 500 MΩ
Moisture Level (MSL)	1	Grado inflamabilidad según UL 94	V-0
Material del contacto	Fósforo, bronce	Superficie de contacto	Oro sobre níquel
Estructura de capas del contacto del conector	30-80 μ" Ni / 30- μ" Au	Temperatura de almacenamiento, min.	-40 °C
Temperatura de almacenamiento, max.	85 °C	Temperatura de servicio, min.	-40 °C
Temperatura de servicio, max.	85 °C		

Hoja técnica

**Datos OMNIMATE - Transformador de conectores
RJ45
RJ45M R12D 3.2N4G/Y RL**

Weidmüller Interface GmbH & Co. KG
Klingenbergstraße 16
D-32758 Detmold
Germany
Fon: +49 5231 14-0
Fax: +49 5231 14-292083
www.weidmueller.com

Datos técnicos

Embalaje

Embalaje	Tape	Longitud de VPE	0 m
Anchura VPE	0 m	Altura de VPE	0 m
Diámetro de bobina de cinta \varnothing (A)	330 mm	Resistencia superficial	$R_s = 10^9 - 10^{12} \Omega$

Clasificaciones

ETIM 6.0	EC002637	eClass 6.2	27-25-05-04
eClass 9.0	27-44-04-02	eClass 9.1	27-44-04-02

Homologaciones en línea

Homologaciones



ROHS Conformidad

Descargas

Datos de ingeniería [STEP](#)

Hoja técnica

**Datos OMNIMATE - Transformador de conectores
RJ45
RJ45M R12D 3.2N4G/Y RL**

Weidmüller Interface GmbH & Co. KG
Klingenbergstraße 16
D-32758 Detmold
Germany
Fon: +49 5231 14-0
Fax: +49 5231 14-292083
www.weidmueller.com

Dibujos

Dibujo acotado

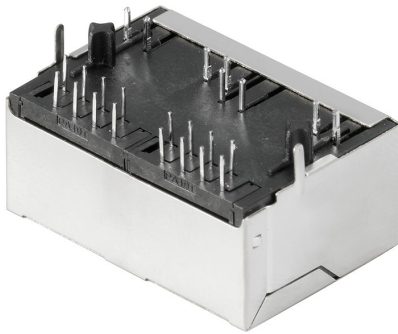

Dibujo acotado

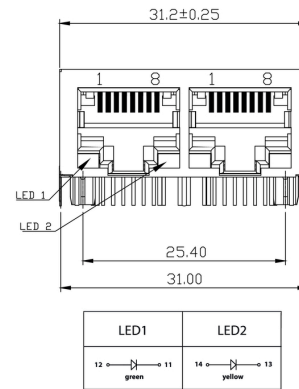

Dibujo acotado

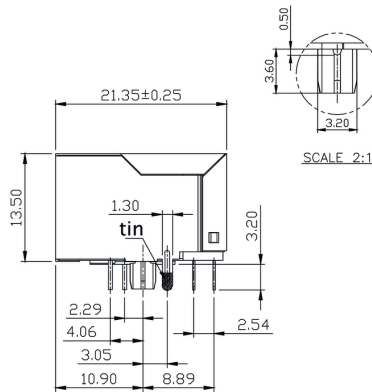

Dibujo acotado

Esquema de conexiones

Diseño de la placa de circuito impreso

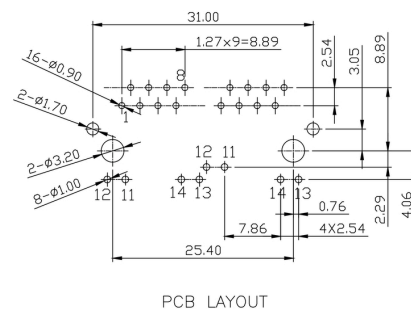

Hoja técnica

**Datos OMNIMATE - Transformador de conectores
RJ45
RJ45M R12D 3.2N4G/Y RL**

Weidmüller Interface GmbH & Co. KG
Klingenbergstraße 16
D-32758 Detmold
Germany
Fon: +49 5231 14-0
Fax: +49 5231 14-292083
www.weidmueller.com

Dibujos

Esquema de conexiones

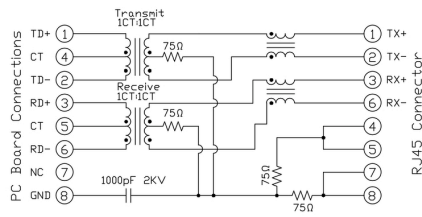

Datos OMNIMATE - Transformador de conectores RJ45 RJ45M R12D 3.2N4G/Y RL

Weidmüller Interface GmbH & Co. KG
 Klingenbergstraße 16
 D-32758 Detmold
 Germany
 Fon: +49 5231 14-0
 Fax: +49 5231 14-292083
 www.weidmueller.com

Dibujos

Schematic

Characteristics

Inductance	350 µH min. @ 100 kHz, 100 mV, 8 mA DC Bias
Leakage Inductance	0.3 µH max. @ 100 kHz, 100 mV
Insertion Loss	1.1 dB max. @ (1 - 100) MHz
Return Loss	18 dB min. @ (1 - 30) MHz 16 dB min. @ (30 - 60) MHz 12 dB min. @ (60 - 80) MHz
Cross Talk	30 dB min. @ (1 - 100) MHz
Common Mode Rejection	30 dB min. @ (1 - 100) MHz

Type codes

Type Code	Parameter	Value	Description
RJ45	Product	RJ45	Product
G1	Performance Category	G1	Category 5, 10/100/1000 Mbit, 10 Gbit, Unshielded
R	Assembly on PCB	R	Through Hole Reflow - THR
I	Direction, latch style	I	Horizontal (90°, side entry), latch up
U	Number of Ports	U	1 Port
3.2	Solder Pin length	3.2	3.2 mm
E	EMI tabs (ground fingers)	E	E = with EMI tabs
4	Contact surface thickness	4	1 = 3µ", 2 = 6µ", 3 = 15µ", 4 = 30µ", 5 = 50µ"
GY/GY	LED	GY/GY	Green-Yellow/Green-Yellow
TY	Packaging	TY	Tray in box (manual assembly)
		RL	Tape on Reel (automated assembly)
		Y/G	Yellow/Green
		G/Y	Green/Yellow (standard)
		O/G	Orange/Green
		R/O	Red/Orange
		N	without LED
		D	SMD
		S	Surface Mount Technology - SMT
		T	Through Hole Technology - THT
		CS	Category 5
		C6	Category 6
		C6A	Category 6A
		C5e	Category 5e
		M	10/100 Mbit
		G1	10/100/1000 Mbit
		G10	10 Gbit
		U	Unshielded
		MP	10/100 Mbit with POE
		MP+	10/100 Mbit with POE+

Recommended wave soldering profiles

Weidmüller Interface GmbH & Co. KG
 Klängenbergstraße 16
 D-32758 Detmold
 Germany
 Fon: +49 5231 14-0
 Fax: +49 5231 14-292083
 www.weidmueller.com

Single Wave:



Double Wave:



Wave soldering profiles

Wired connection elements should be processed in accordance with the DIN EN 61760-1 standard. We have included two recommendations for practical wave soldering profiles, with which Weidmüller PCB terminals and connectors are qualified.

When choosing a suitable profile for your application, the following factors also need to be considered:

- PCB thickness
- Proportion of Cu in the layers
- Single/double-sided assembly
- Product range
- Heating and cooling rates

The single and double wave profiles each indicate the recommended operating range, including the maximum soldering temperature of 260°C. In practice, the maximum soldering temperature is quite often well below the above maximum profile.

Recommended reflow soldering profile

Weidmüller Interface GmbH & Co. KG
 Klingenbergstraße 16
 D-32758 Detmold
 Germany
 Fon: +49 5231 14-0
 Fax: +49 5231 14-292083
 www.weidmueller.com



Reflow soldering profile

The perfect soldering profile for SMT Surface Mount Technology is one the most exiting question in SMT production. But there are more than one correct answer: The diagram of temperature-on-time is related to processing features of solder paste and to maximum load of components.

We have to consider the following parameters:

- Time for pre heating
- Maximum temperature
- Time above melting point
- Time for cooling
- Maximum heating rate
- Maximum cooling rate

We recommend a typical solder profile with associated process limits. With preheating components and board are prepared smoothly for the solder phase. Heating rate is typically $\leq +3\text{K/s}$. In parallel the solder paste is ‚activated‘. The time above melting point of 217°C the paste gets liquid and components and boards begin to connect. The maximum temperature of 245°C to 254°C should stay between 10 and 40 seconds. In the cooling phase at $\geq -6\text{K/s}$ solder is cured. Board and components cool down while avoiding cold cracks.