

Fiche technique | Numéro d'article: 286-830
module redresseur; Tension d'entrée 24V AC; avec dispositif
d'antiparasitage varistance

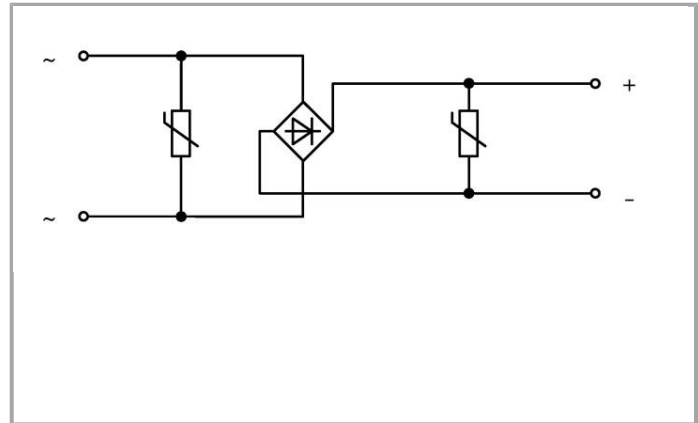

www.wago.com/286-830

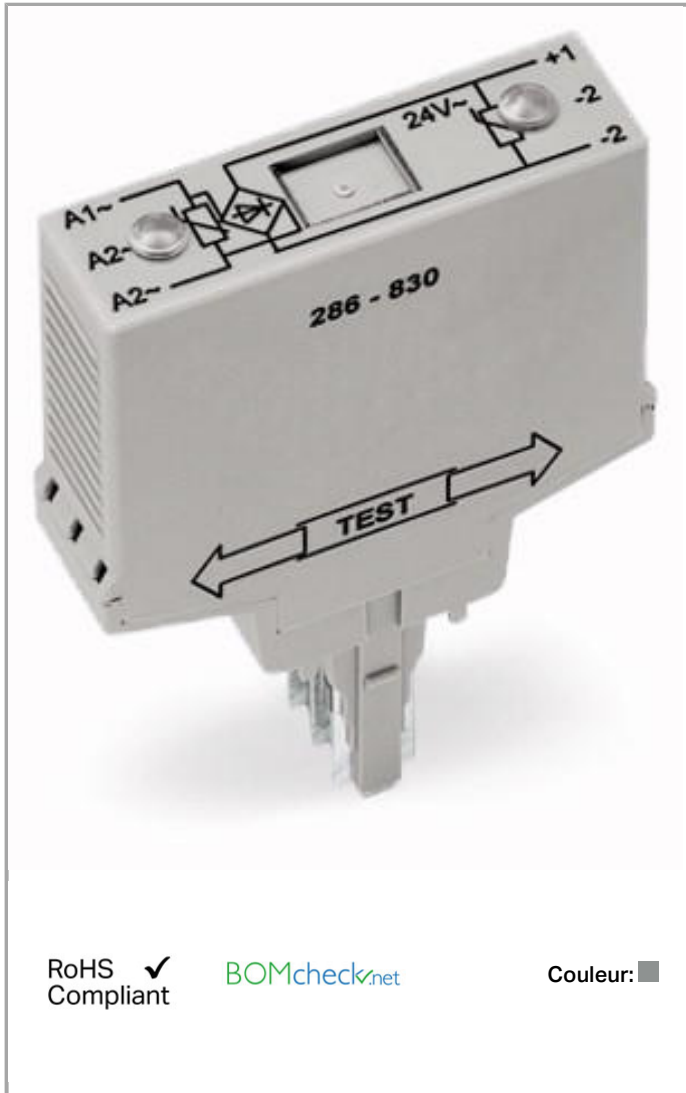
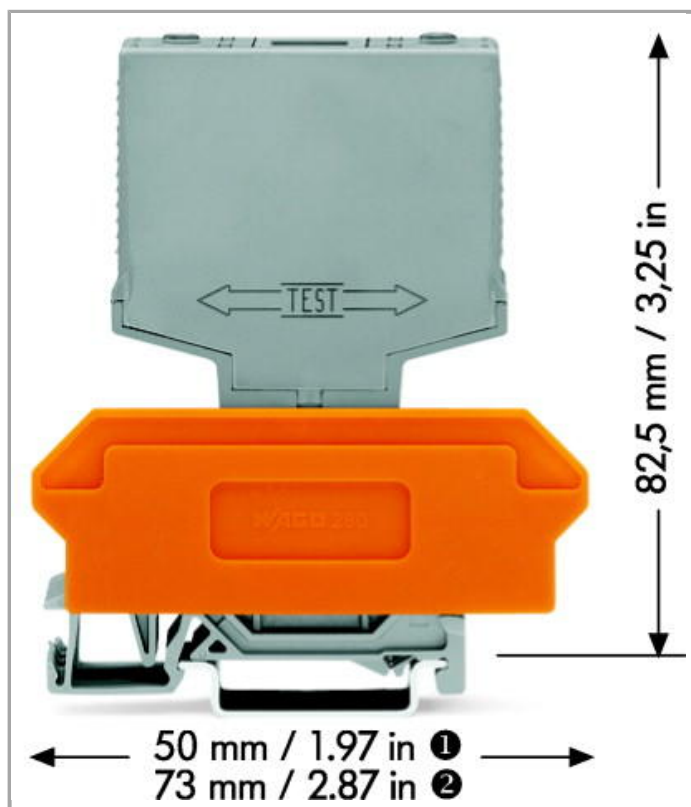

**Données****Données électriques**

Nominal operating voltage	24 VAC
Operating voltage	≤ 35 VAC
Courant nominal	1 A
Capacité de mise sous tension	< 2200 μF

Données géométriques

Largeur	15 mm / 0.591 inch
---------	--------------------

Données mécaniques

Type de montage	Module débrochable pour blocs de bornes de base
En boîtier	Pluggable module for terminal blocks

Données du matériau

Couleur	gris
Charge calorifique	0.337 MJ
Poids	21.577 g

Conditions d'environnement

Température ambiante (fonctionnement)	-25 ... 40 °C
---------------------------------------	---------------

Dates commerciales

Country of origin	DE
GTIN	4045454549848
Customs Tariff No.	85369010000
Product Group	6 (Interface Electronics)

Produits correspondants

Marking accessories



N° art.: 209-701
Carte de repérage WSB; en carte; non extensible; vierge; encliquetable

www.wago.com/209-701



N° art.: 209-701/000-002
Carte de repérage WSB; en carte; non extensible; vierge; encliquetable

www.wago.com/209-701/000-002



N° art.: 209-701/000-005
Carte de repérage WSB; en carte; non extensible; vierge; encliquetable

www.wago.com/209-701/000-005



N° art.: 209-701/000-006
Carte de repérage WSB; en carte; non extensible; vierge; encliquetable

www.wago.com/209-701/000-006



N° art.: 209-701/000-007
Carte de repérage WSB; en carte; non extensible; vierge; encliquetable

www.wago.com/209-701/000-007



N° art.: 209-701/000-012
Carte de repérage WSB; en carte; non extensible; vierge; encliquetable

www.wago.com/209-701/000-012



N° art.: 209-701/000-017
Carte de repérage WSB; en carte; non extensible; vierge; encliquetable

www.wago.com/209-701/000-017



N° art.: 209-701/000-023
Carte de repérage WSB; en carte; non extensible; vierge; encliquetable

www.wago.com/209-701/000-023



N° art.: 209-701/000-024
Carte de repérage WSB; en carte; non extensible; vierge; encliquetable

www.wago.com/209-701/000-024

Téléchargements

Documentation



Bid Text

286-830 Interface-Bausteine mit Sonderfunktionen	Jan 15, 2016	DOC 24,6 kB	Téléchargement
---	--------------	----------------	----------------

Additional Information

Disposal; Electrical and electronic equipment, Packaging	V 1.0.0 Oct 15, 2018	PDF 269,1 kB	Téléchargement
--	-------------------------	-----------------	----------------

Sous réserve de modifications.