

**Données OMNIMATE - Transformateur Prises RJ45  
RJ45G1 R12D 3.2N4YG/YG RL**

**Weidmüller Interface GmbH & Co. KG**  
 Klingenbergstraße 16  
 D-32758 Detmold  
 Germany  
 Fon: +49 5231 14-0  
 Fax: +49 5231 14-292083  
 www.weidmueller.com



Les connecteurs d'émetteur RJ45 (magnétique) pour applications gigabit (1000 base-T) avec compensation intégrée compensent activement les couplages inductifs et capacitifs et gagne de la place sur le circuit imprimé.

- Systèmes de soudure THT ou THR
- Large gamme de formes, également avec des LED intégrées et des languettes de contact blindage
- Version emballée sur plateau (TY) ou en rouleau (Tape-on-Reel, RL)
- Plage de température étendue de -40 °C à +85 °C
- Couche d'or renforcée pour une protection contre la corrosion améliorée
- Vitesses de transmission jusqu'à 1 Gbit/s

**Informations générales de commande**

Type	RJ45G1 R12D 3.2N4YG/YG RL
Référence	<a href="#">2485370000</a>
Version	Connecteur pour circuit imprimé, Transformateur prises RJ45, 1000 Mbit/s , Raccordement soudé THT/THR, 90°, Option de verrouillage: bas, Languettes de blindage: aucun, 30-80 µ" Ni / 30-µ" Au , LED: Oui, Vert/jaune, Vert/jaune, Nombre de pôles: 8, Tape
GTIN (EAN)	4050118495966
Cdt.	200 pièce(s)
Emballage	Tape

**Données OMNIMATE - Transformateur Prises RJ45  
RJ45G1 R12D 3.2N4YG/YG RL**

**Weidmüller Interface GmbH & Co. KG**  
Klingenbergstraße 16  
D-32758 Detmold  
Germany  
Fon: +49 5231 14-0  
Fax: +49 5231 14-292083  
www.weidmueller.com

**Caractéristiques techniques**
**Dimensions et poids**

Largeur	31,2 mm	Largeur (pouces)	1,228 inch
Hauteur	16,9 mm	Hauteur (pouces)	0,665 inch
Hauteur version la plus basse	13,6 mm	Profondeur	21,5 mm
Profondeur (pouces)	0,846 inch	Poids net	8,81 g

**Températures**

Température de fonctionnement , max.	85 °C	Température de fonctionnement , min.	-40 °C
Température de stockage, max.	85 °C	Température de stockage, min.	-40 °C

**Conformité environnementale du produit**

REACH SVHC	Lead 7439-92-1
------------	----------------

**Caractéristiques du système**

Angle de sortie	90°	Blindage	Oui
Couleur LED droite	Vert/jaune	Couleur LED gauche	Vert/jaune
Cycles d'enfichage	750	Degré de protection	IP20
Famille de produits	Données OMNIMATE - Transformateur Prises RJ45	LED	Oui
Languettes de blindage	aucun	Longueur du picot à souder (l)	3,2 mm
Matériau de blindage	Laiton	Montage sur le circuit imprimé	Raccordement soudé THT/ THR
Nombre de picots par pôle	1	Nombre de pôles	8
Option de verrouillage	bas	Pas en mm (P)	1,27 mm
Pas en pouces (P)	0,05 inch	Surface de blindage	nickelé
Type de raccordement	Femelle	Vitesse de transmission	1000 Mbit/s

**Propriétés électriques**

Courant nominal	1,5 A	Rigidité diélectrique, contact - blindage	1500 V DC
Rigidité diélectrique, contact - contact	≥ 1000 V DC	Tension nominale	125 V AC
Tenue d'isolation	> 500 MΩ		

**Données des matériaux**

Matériau isolant	PA 9T	Couleur	noir
Tableau des couleurs (similaire)	RAL 9011	Groupe de matériaux isolants	II
CTI	≥ 500	Tenue d'isolation	> 500 MΩ
Moisture Level (MSL)	1	Classe d'inflammabilité selon UL 94	V-0
Matériau de base du contact	Bronze phosphoreux	Surface du contact	Or sur nickel
Structure en couches du contact mâle	30-80 μ" Ni / 30- μ" Au	Température de stockage, min.	-40 °C
Température de stockage, max.	85 °C	Température de fonctionnement , min.	-40 °C
Température de fonctionnement , max.	85 °C		

**Emballage**

Emballage	Tape	Longueur VPE	360 mm
Largeur VPE	360 mm	Hauteur VPE	120 mm
Diamètre de bobine du ruban Ø (A)	330 mm	Résistance de la surface	Rs = 10 <sup>9</sup> - 10 <sup>12</sup> Ω

**Fiche de données****Données OMNIMATE - Transformateur Prises RJ45  
RJ45G1 R12D 3.2N4YG/YG RL**

**Weidmüller Interface GmbH & Co. KG**  
Klingenbergstraße 16  
D-32758 Detmold  
Germany  
Fon: +49 5231 14-0  
Fax: +49 5231 14-292083  
www.weidmueller.com

**Caractéristiques techniques****Classifications**

ETIM 6.0	EC002637	eClass 6.2	27-25-05-04
eClass 9.0	27-44-04-02	eClass 9.1	27-44-04-02

**Agréments**

Agréments



ROHS Conforme

**Téléchargements**

Documentation utilisateur	<a href="#">MAN I E GUIDE DE</a> <a href="#">MAN I E GUIDE EN</a>
Données techniques	<a href="#">STEP</a>

**Fiche de données**

**Données OMNIMATE - Transformateur Prises RJ45  
RJ45G1 R12D 3.2N4YG/YG RL**

**Weidmüller Interface GmbH & Co. KG**  
Klingenbergstraße 16  
D-32758 Detmold  
Germany  
Fon: +49 5231 14-0  
Fax: +49 5231 14-292083  
www.weidmueller.com

**Dessins**

**Dessin coté**

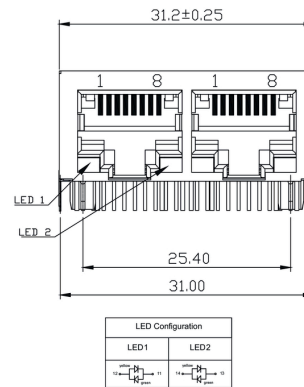

**Dessin coté**

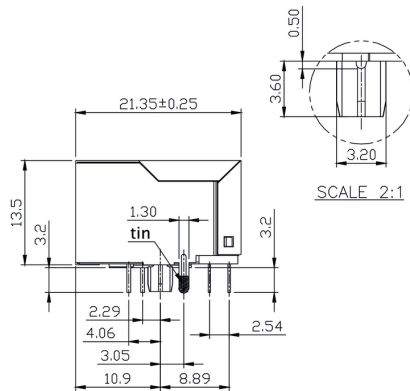

**Schéma**

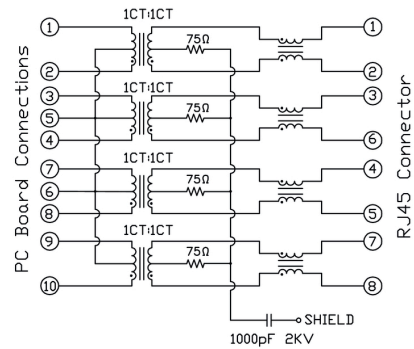

**Conception de la plaque de circuit imprimé**

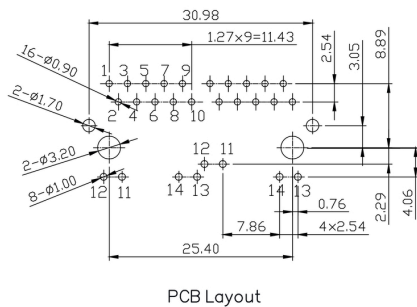

## Données OMNIMATE - Transformateur Prises RJ45 RJ45G1 R12D 3.2N4YG/YG RL

**Weidmüller Interface GmbH & Co. KG**  
 Klingenbergstraße 16  
 D-32758 Detmold  
 Germany  
 Fon: +49 5231 14-0  
 Fax: +49 5231 14-292083  
 www.weidmueller.com

### Dessins

### Schematic

#### Characteristics

Inductance	350 µH min. @ 100 kHz, 100 mV, 8 mA DC Bias
Leakage Inductance	0.3 µH max. @ 100 kHz, 100 mV
Insertion Loss	1.1 dB max. @ (1 - 100) MHz
Return Loss	18 dB min. @ (1 - 30) MHz 16 dB min. @ (30 - 60) MHz 12 dB min. @ (60 - 80) MHz
Cross Talk	30 dB min. @ (1 - 100) MHz
Common Mode Rejection	30 dB min. @ (1 - 100) MHz

### Type codes

Type Code	Parameter	Value	Description
RJ45	Product	RJ45	Product
G1	Performance Category	G1	Category 5, 10/100/1000 Mbit
R	Assembly on PCB	R	Through Hole Reflow - THR
I	Direction, latch style	I	Horizontal (90°, side entry), latch up
U	Number of Ports	U	1 Port
3.2	Solder Pin length	3.2	3.2 mm
E	EMI tabs (ground fingers)	E	with EMI tabs
4	Contact surface thickness	4	1 = 3µ", 2 = 6µ", 3 = 15µ", 4 = 30µ", 5 = 50µ"
GY/GY	LED	GY/GY	Green-Yellow/Green-Yellow
TY	Packaging	TY	Tray in box (manual assembly)
		RL	Tape on Reel (automated assembly)
		Y/G	Yellow/Green
		G/Y	Green/Yellow (standard)
		GY/GY	Green-Yellow/Green-Yellow
		O/G	Orange/Green
		R/O	Red/Orange
		...	... (further combinations possible)
		N	without LED
		D	SMD
		V	Vertical (180°, top entry), latch down
		Y	Diagonal (45°), latch up
		S	Surface Mount Technology - SMT
		T	Through Hole Technology - THT
		MP	10/100 Mbit with POE
		MP+	10/100 Mbit with POE+

## Recommended wave soldering profiles

**Weidmüller Interface GmbH & Co. KG**  
 Klängenbergstraße 16  
 D-32758 Detmold  
 Germany  
 Fon: +49 5231 14-0  
 Fax: +49 5231 14-292083  
 www.weidmueller.com

### Single Wave:



### Double Wave:



### Wave soldering profiles

Wired connection elements should be processed in accordance with the DIN EN 61760-1 standard. We have included two recommendations for practical wave soldering profiles, with which Weidmüller PCB terminals and connectors are qualified.

When choosing a suitable profile for your application, the following factors also need to be considered:

- PCB thickness
- Proportion of Cu in the layers
- Single/double-sided assembly
- Product range
- Heating and cooling rates

The single and double wave profiles each indicate the recommended operating range, including the maximum soldering temperature of 260°C. In practice, the maximum soldering temperature is quite often well below the above maximum profile.

## Recommended reflow soldering profile

**Weidmüller Interface GmbH & Co. KG**  
 Klingenbergstraße 16  
 D-32758 Detmold  
 Germany  
 Fon: +49 5231 14-0  
 Fax: +49 5231 14-292083  
 www.weidmueller.com

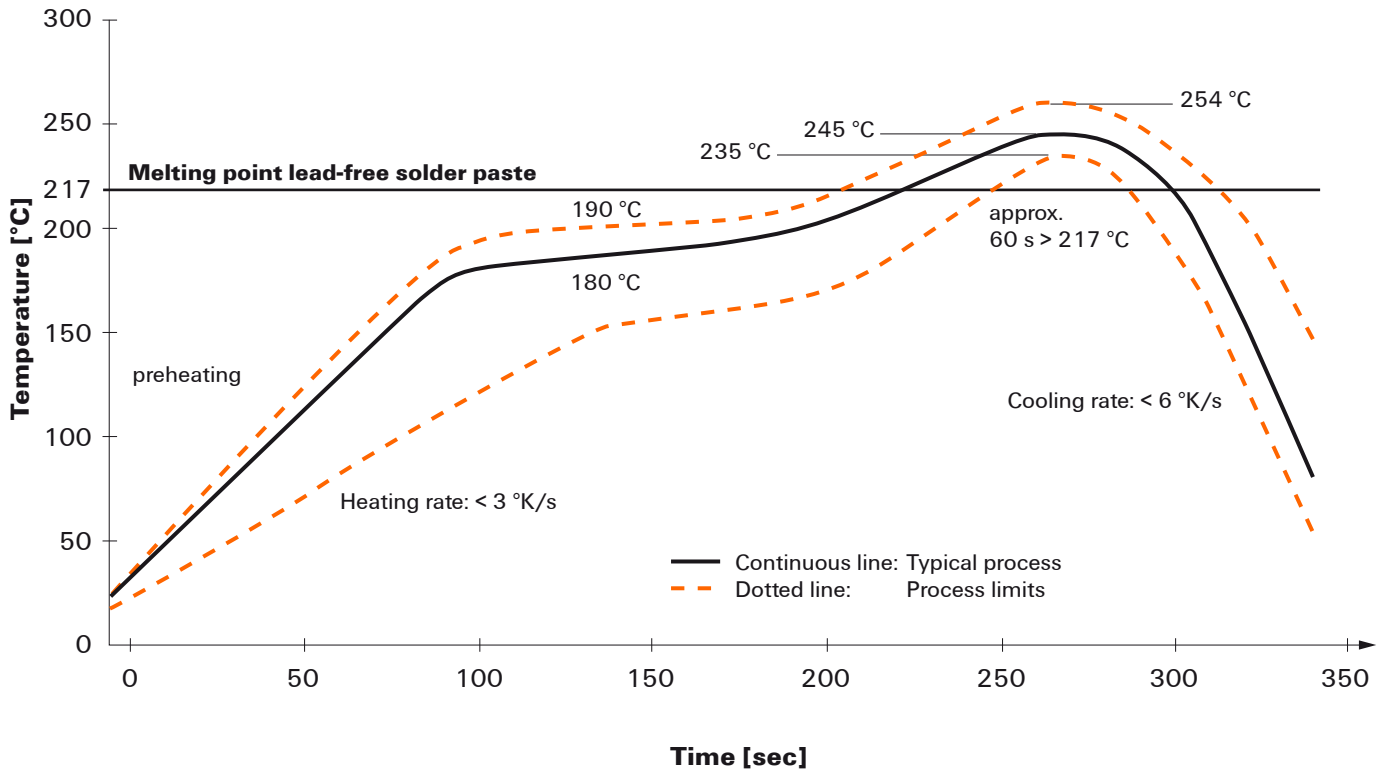

### Reflow soldering profile

The perfect soldering profile for SMT Surface Mount Technology is one the most exiting question in SMT production. But there are more than one correct answer: The diagram of temperature-on-time is related to processing features of solder paste and to maximum load of components.

We have to consider the following parameters:

- Time for pre heating
- Maximum temperature
- Time above melting point
- Time for cooling
- Maximum heating rate
- Maximum cooling rate

We recommend a typical solder profile with associated process limits. With preheating components and board are prepared smoothly for the solder phase. Heating rate is typically  $\leq +3\text{K/s}$ . In parallel the solder paste is ‚activated‘. The time above melting point of 217°C the paste gets liquid and components and boards begin to connect. The maximum temperature of 245°C to 254°C should stay between 10 and 40 seconds. In the cooling phase at  $\geq -6\text{K/s}$  solder is cured. Board and components cool down while avoiding cold cracks.