

SB1220 ... SB12100

Schottky Barrier Rectifiers Schottky-BARRIER-Gleichrichter

Version 2006-12-08

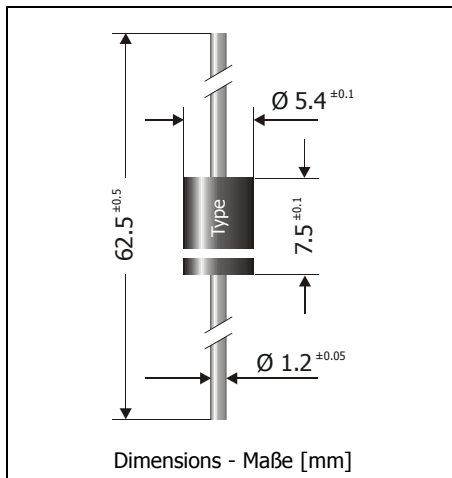

Nominal current Nennstrom	12 A
Repetitive peak reverse voltage Periodische Spitzensperrspannung	20...100 V
Plastic case Kunststoffgehäuse	Ø 5.4 x 7.5 [mm]
Weight approx. Gewicht ca.	1.0 g
Plastic material has UL classification 94V-0 Gehäusematerial UL94V-0 klassifiziert	
Standard packaging taped in ammo pack Standard Lieferform gegurtet in Ammo-Pack	

**Maximum ratings****Grenzwerte**

Type Typ	Repetitive peak reverse voltage Periodische Spitzensperrspannung V_{RRM} [V]	Surge peak reverse voltage Stoßspitzensperrspannung V_{RSM} [V]	Forward voltage Durchlass-Spannung V_F [V] ¹⁾	
			$I_F = 5$ A	$I_F = 12$ A
SB1220	20	20	< 0.45	< 0.55
SB1230	30	30	< 0.45	< 0.55
SB1240	40	40	< 0.45	< 0.55
SB1250	50	50	< 0.61	< 0.68
SB1260	60	60	< 0.61	< 0.68
SB1290	90	90	< 0.75	< 0.83
SB12100	100	100	< 0.75	< 0.83

Max. average forward rectified current, R-load Dauergrenzstrom in Einwegschaltung mit R-Last	$T_A = 50^\circ\text{C}$	I_{FAV}	12 A ²⁾
Repetitive peak forward current Periodischer Spitzenstrom	$f > 15$ Hz	I_{FRM}	55 A ²⁾
Peak forward surge current, 50/60 Hz half sine-wave Stoßstrom für eine 50/60 Hz Sinus-Halbwelle	$T_A = 25^\circ\text{C}$	I_{FSM}	280/320 A
Rating for fusing – Grenzlastintegral, $t < 10$ ms	$T_A = 25^\circ\text{C}$	i^2t	390 A ² s
Junction temperature – Sperrschichttemperatur at reduced reverse voltage bei reduzierter Sperrspannung in DC forward mode – bei Gleichstrom-Durchlassbetrieb	$V_R \leq 80\% V_{RRM}$ $V_R \leq 50\% V_{RRM}$	T_j T_j T_j	-50...+150°C $\leq 180^\circ\text{C}$ $\leq 200^\circ\text{C}$
Storage temperature – Lagerungstemperatur		T_s	-50...+175°C

1 $T_j = 25^\circ\text{C}$ 2 Valid, if leads are kept at ambient temperature at a distance of 10 mm from case
Gültig, wenn die Anschlussdrähte in 10 mm Abstand vom Gehäuse auf Umgebungstemperatur gehalten werden

Characteristics
Kennwerte

Leakage current Sperrstrom	$T_j = 25^\circ\text{C}$ $T_j = 100^\circ\text{C}$	$V_R = V_{RRM}$ $V_R = V_{RRM}$	I_R I_R	< 500 μA < 20 mA
Thermal resistance junction to ambient air Wärmewiderstand Sperrschicht – umgebende Luft			R_{thA}	< 14 K/W ¹⁾
Thermal resistance junction to leads Wärmewiderstand Sperrschicht – Anschlussdraht			R_{thL}	< 4 K/W

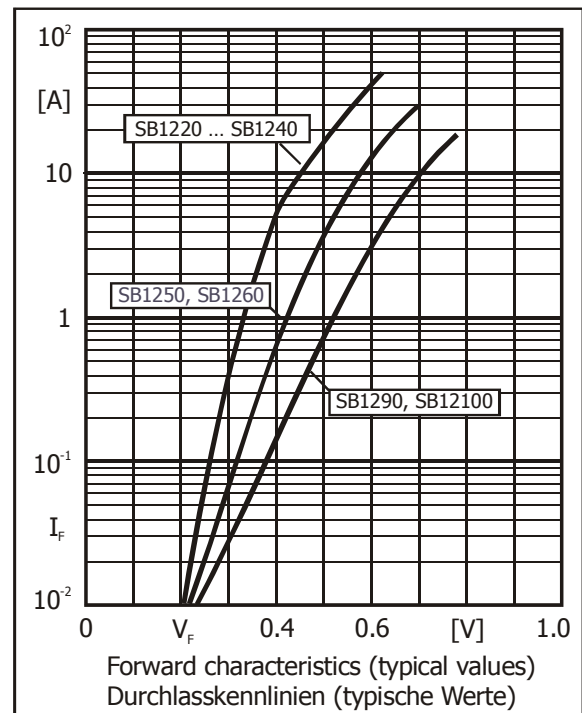
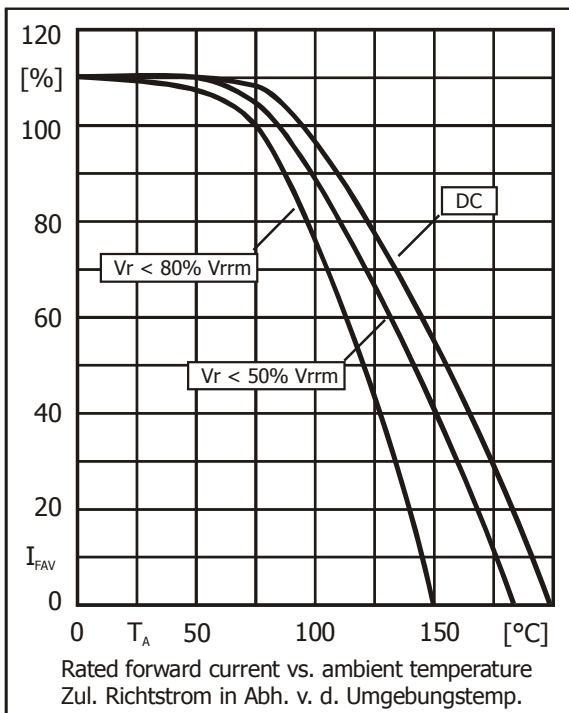

1 Valid, if leads are kept at ambient temperature at a distance of 10 mm from case
Gültig, wenn die Anschlussdrähte in 10 mm Abstand vom Gehäuse auf Umgebungstemperatur gehalten werden