

mini-regolatore di pressione

mini pressure regulator



- Regolatore a pistone con valvola di scarico sovrappressione (relieving)
Piston-type pressure regulator with relieving
- Autocompensazione durante la regolazione
Self-compensated regulation
- Corpo in alluminio 11S
Body in aluminium 11S
- Grande sensibilità
Sensitive regulation
- Installazione in linea o a pannello
In-line or panel mounting



CODICE DI ORDINAZIONE <i>ORDER CODE</i>		MREG 1-08	MREG 2-08	MREG 2-04
Attacchi <i>Ports</i>		G1/8"	G1/4"	G1/4"
Temperatura di esercizio <i>Temperature range</i>		max +50°C	max +50°C	max +50°C
Pressione di alimentazione <i>Inlet pressure range</i>	$p_{1 \text{ min}}$ $p_{1 \text{ max}}$	0 bar; 0 MPa 10 bar; 1 MPa	0 bar; 0 MPa 10 bar; 1 MPa	0 bar; 0 MPa 10 bar; 1 MPa
Pressione di utilizzo <i>Outlet pressure range</i>	$p_{2 \text{ min}}$ $p_{2 \text{ max}}$	0.5 bar; 0.05 MPa 8 bar; 0.8 MPa	0.5 bar; 0.05 MPa 8 bar; 0.8 MPa	0.5 bar; 0.05 MPa 4 bar; 0.4 MPa
Differenza minima di pressione (Δp) <i>Minimum pressure difference (Δp)</i>	$p_1 - p_2$	0.2 bar; 0.02 MPa	0.2 bar; 0.02 MPa	0.2 bar; 0.02 MPa
Isteresi <i>Hysteresis</i>	$p_1 = 10 \text{ bar} / p_2 = 0 \text{ bar}$ $p_1 = 10 \text{ bar} / p_2 = 8 \text{ bar}$	1.6 0.6	1.6 0.6	1.6 0.6
Portata raccomandata <i>Recommended flow rate</i>	$p_2 = 6.3 \text{ bar a } 25 \text{ m/s}$ $p_2 = 6.3 \text{ bar at } 25 \text{ m/s}$	Q_n	300 NI/min	550 NI/min

Caratteristiche di portata (MREG 2-08)
Flow characteristics (MREG 2-08)

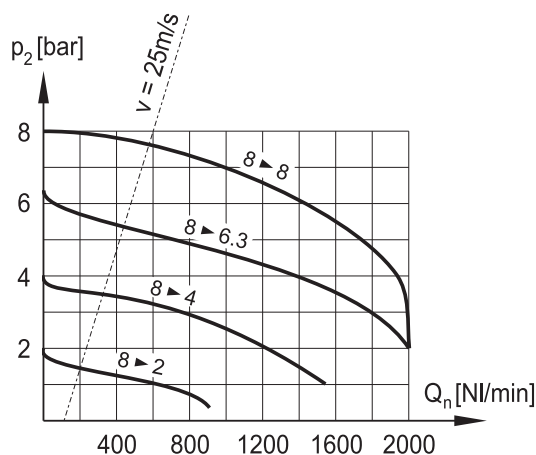

Variazione della pressione di utilizzo in presenza di fluttuazioni della pressione di alimentazione (MREG 2-08)
Outlet pressure variation with fluctuating inlet pressure (MREG 2-08)

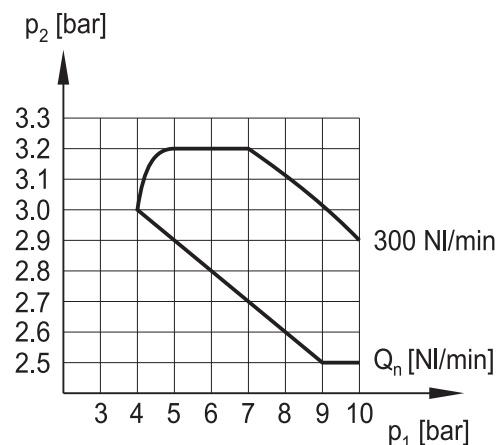

mini-regolatore di pressione

mini pressure regulator



Il manometro deve essere acquistato separatamente.
The manometer is bought separately.

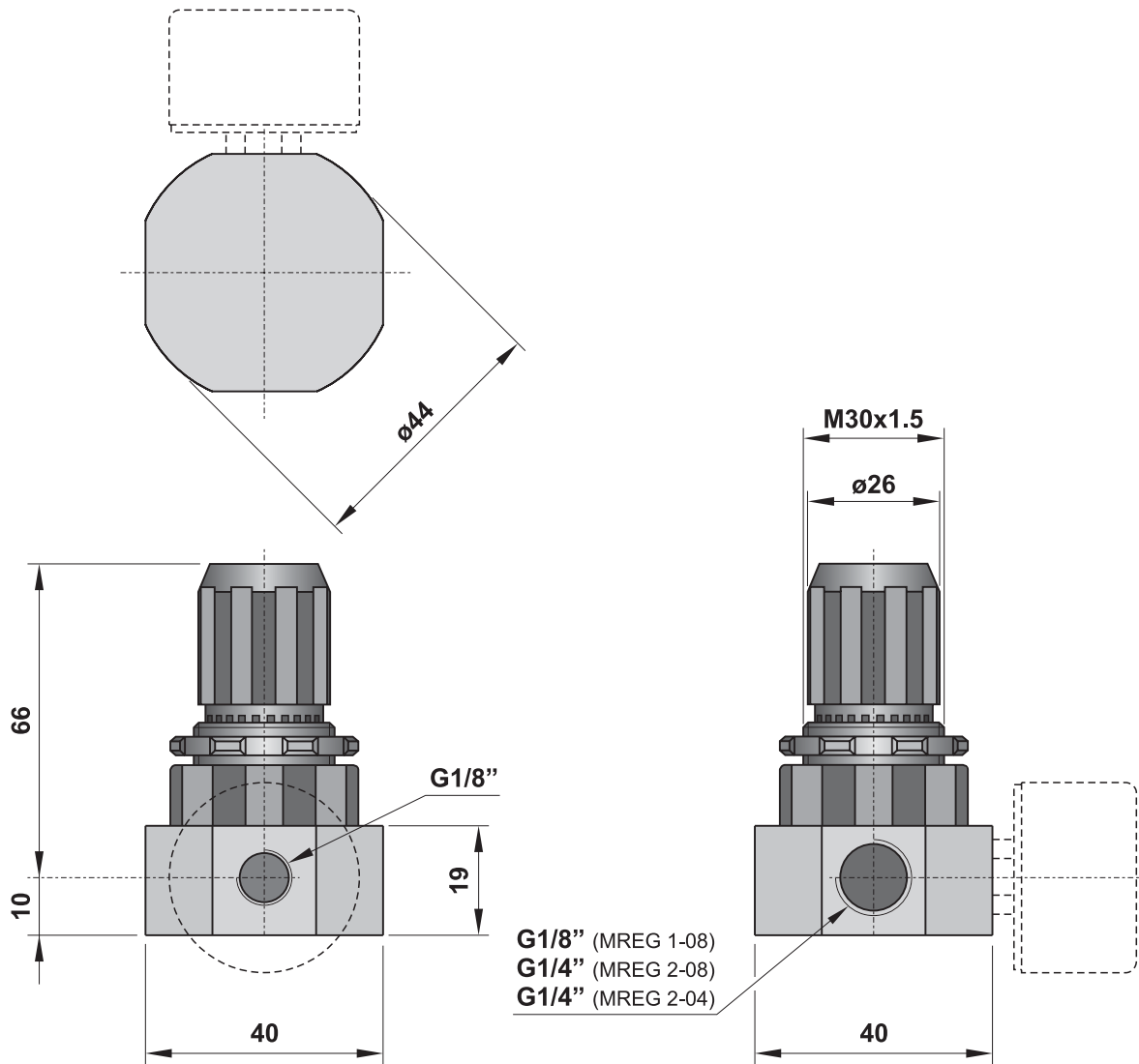
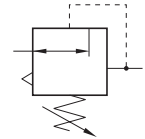

Materiali

Corpo: alluminio 11S anodizzato naturale

Molle: INOX

Guarnizioni: NBR

Parti interne: ottone, INOX e polimeri

Materials

Body: aluminium 11S (natural anodize treatment)

Springs: stainless steel

Seals: NBR

Internal parts: brass, stainless steel and polymer