



Référence: E13*10R05/01*15073*00

Annexes: - Rapport Technique
- Fiche de Renseignements du constructeur

Luxembourg, le 20 mars 2019

Communication concernant ⁽²⁾:

Communication concerning:

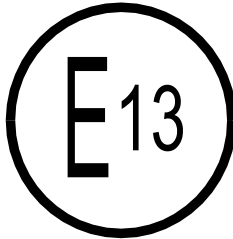

- **la délivrance d'une homologation**
approval granted
- ~~**l'extension d'homologation**~~
approval extended
- ~~**le refus d'homologation**~~
approval refused
- ~~**le retrait d'homologation**~~
approval withdrawn
- ~~**l'arrêt définitif de la production**~~
production definitively discontinued

d'un type de sous-ensemble électrique/électronique ⁽²⁾ en ce qui concerne le Règlement N° 10.
of a type of electrical/electronic sub-assembly with regard to Regulation N° 10.

Numéro d'homologation par type:

Approval number:

E13*10R05/01*15073*00

Marque d'homologation:

Approval mark:

 10R - 05 15073

1. Fabricant (marque commerciale du constructeur):

Make (trade name of manufacturer):

SecoRüt

2. Type:

Type:

60xxx Series

Dénomination(s) commerciale(s) générale(s):

General commercial description(s):

Voltage Reducer

Version(s)/Variant(s):

Version(s)/Variant(s):

60185, 60180, 60181, 60183, 60186, 60191, 60192,
60193, 60194, 60195, 60197, 60226, 60228

- 3. Moyens d'identification du type, s'ils sont marqués sur le composant / entité technique ⁽²⁾:**
Means of identification of type, if marked on the component / separate technical unit: Label stick on the housing of product 60xxx Series
- 3.1. Emplacement de ce marquage:**
Location of that marking: Refer to page 5 of manufacturer's information document
- 4. Catégorie du véhicule:**
Category of vehicle: Not applicable
- 5. Nom et adresse du constructeur:**
Name and address of manufacturer: SecoRüt Kfz Electronic GmbH
Obere Dorfstrasse 56
D-34355 Staufenberg
- 6. Dans le cas de composants ou d'entités techniques, emplacement et procédé de fixation de la marque de réception CEE:**
In the case of components and separate technical units, location and method of affixing of the ECE approval mark: Moulded on housing of product 60xxx Series
- 7. Adresse(s) de l' (des) usine(s) d'assemblage:**
Address(es) of assembly plant(s): SecoRüt Kfz Electronic GmbH
Obere Dorfstrasse 56
D-34355 Staufenberg
- 8. Informations supplémentaires (s'il y a lieu):**
Additional informations (where applicable): See appendix below
- 9. Autorité déléguée:**
Assigned authority: *Société Nationale de Certification et d'Homologation L-5201 Sandweiler*
- Service technique responsable de l'exécution des essais:**
Technical service responsible for carrying out the tests: TÜV Rheinland Luxemburg GmbH
2a, Kalchesbruck
L-1852 Luxembourg
- 10. Date du rapport d'essai:**
Date of test report: 14.01.2019
- 11. Numéro du rapport d'essai:**
Number of test report: 87-R10-0252/19-00
- 12. Remarques (s'il y a lieu):**
Remarks (if any): See appendix below

13. **Lieu:** Luxembourg
Place:

14. **Date:** 20 mars 2019
Date:

15. **Signature:**
Signature:

**Pour le Ministre de la Mobilité
et des Travaux publics**



Alain DISVISCOUR
Conseiller

Pour la SNCH

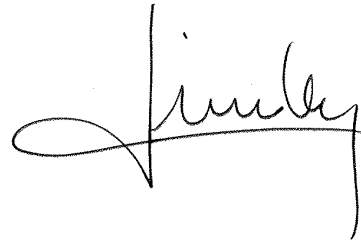

Laurent LINDEN
Attaché de Direction



16. **L'index de l'ensemble des renseignements déposé chez l'autorité de réception, qui peut être obtenu sur demande, est joint.**

The index to the information package lodged with the approval authority, which may be obtained on request, is attached.

See index to type-approval report

17. **Raison(s) de l'extension:** Not applicable
Reason(s) for extension:

Appendice Appendix

au certificat d'homologation par type N° E13*10R05/01*15073*00
to type-approval certificate N° E13*10R05/01*15073*00
concernant l'homologation par type d'un sous ensemble électrique/électronique selon le Règlement N° 10.
concerning the type-approval of an electrical/electronic sub-assembly under Regulation N° 10.

- | | | |
|---------------|--|---|
| 1. | Informations supplémentaires.
Additional information. | |
| 1.1. | Tension nominale du système électrique [V]:
Electrical system rated voltage [V]: | 24V DC |
| | Masse:
Ground: | Positive/Negative ⁽²⁾ |
| 1.2. | Ce SEEE peut être utilisé sur n'importe quel type de véhicule avec les restrictions suivantes:
This ESA can be used on any vehicle type with the following restrictions: | All vehicles with 24V respectively electrical wiring and battery at the body |
| 1.2.1. | Conditions d'installation, s'il y a lieu:
Installation conditions, if any: | Connected to the battery of the vehicle |
| 1.3. | Ce SEEE peut seulement être utilisé sur les types de véhicules suivants:
This ESA can be used only on the following vehicle types: | Not applicable |
| 1.3.1. | Conditions d'installation, s'il y a lieu:
Installation conditions, if any: | Not applicable |
| 1.4. | La (les) méthode(s) spécifique(s) d'essais utilisée(s) et les bandes de fréquences couvertes pour déterminer l'immunité étai(ent): (indiquez s'il vous plaît à partir de l'annexe 9 la méthode précise utilisée).
The specific test method(s) used and the frequency ranges covered to determine immunity were: (Please specify precise method used from annex 9). | Bulk current injection 20 to 400 MHz
ISO 11452-4, 3 rd edition 2005 and Corrigendum 1:2009
Free field 400 to 2000 MHz
ISO 11452-2 2nd edition: 2004 |
| 1.5. | Laboratoire accrédité au titre de la norme ISO 17025 et reconnu par l'autorité d'homologation chargée d'effectuer les essais:
Laboratory accredited to ISO 17025 and recognized by the Approval Authority responsible for carrying out the tests: | Not applicable |
| 2. | Commentaires:
Remarks: | Not applicable |

² **Biffer la mention inutile**
Strike out what does not apply



Référence: E13*10R05/01*15073*00

Annexes: - Rapport Technique
- Fiche de Renseignements du constructeur

Luxembourg, le 20 mars 2019

Index du dossier d'homologation

Index to type-approval report

	Numéro d'homologation: Approval number:	E13*10R05/01*15073*00
	Révision: Revision:	00
	Marque de fabrication ou de commerce: Trade name or mark:	SecoRiit
	Type: Type:	60xxx Series
1.	Procès-verbal d'essai: Test report:	N° 87-R10-0252/19-00
	- Test report:	Page 1 to 4
	- Technical information:	Appendix L - Page 5 & 6
	- List of modifications:	Appendix 0 - Page 7
	- Test protocol:	Appendix 1 - Page 8 to 13
2.	Dossier du constructeur: Report of the manufacturer:	N° 60xxx Series-00
	- Manufacturer's information document:	Page 1 to 13
3.	Autres documents annexés: Other documents annexed:	Not applicable
4.	Date de délivrance de l'homologation initiale: Date of issue of initial type approval:	20.03.2019
5.	Date de la dernière délivrance de pages révisées: Date of last issue of revised pages:	Not applicable
6.	Date de la dernière délivrance d'une homologation révisée: Date of last extension:	Not applicable

Type : 60xxx Series
Manufacturer : SecoRüt Kfz Electronic GmbH

TEST REPORT

according to UN-Regulation

**Uniform provisions concerning the approval of vehicles
with regard to electromagnetic compatibility**

UN-R10

including all amendments until
Supplement 1 to the 05 series of amendments

Previously granted

UN approval : ---

Structure of the Test Report

Item No.

0. General information
 1. Tested vehicle(s) / object(s)
 2. Test record
 3. List of appendices
 4. Statement of conformity
-

The Test Report shall be reproduced and published in full by the client only. It shall however be reproduced partially with the written permission of the Testing Laboratory only.

Type : 60xxx Series
Manufacturer : SecoRüt Kfz Electronic GmbH

0. General information

- 0.1. Make (trade name of the manufacturer) : SecoRüt
- 0.2. Type : 60xxx Series
- 0.3. Category of vehicle : Not applicable
- 0.4. Name and address of the manufacturer : SecoRüt Kfz Electronic GmbH
Obere Dorfstrasse 56 34355 Staufenberg, Germany
- 0.5. No. of the information folder : 60xxx Series-00
- Date of issue : November 13, 2018
- Date of last change : Not applicable

1. Tested ~~vehicle(s)~~/ object(s)

- 1.1. Description
- 1.1.1. ~~Vehicle~~/ object
- Commercial description : Voltage Reducer
- Type(s) /~~variant(s)~~/version(s) : 60xxx Series/---/60185
- Identification number : Not applicable
- 1.1.2. Condition of ~~vehicle(s)~~/Object(s) : New / ~~used~~ / ~~pre-tested~~
- 1.2. Worst case selection : The determination of the worst case was done according to internal procedures of the Technical Service (QMA 1.301.005, section 6.2.2.2.).
- 1.3. Remarks : N.A.

Type : 60xxx Series
 Manufacturer : SecoRüt Kfz Electronic GmbH

2. Test record

- 2.1. Equipment for measuring and testing : The test facilities / measurement equipment used were in compliance with the test requirements
- 2.1.1. Specifications for the test site : Not applicable
- 2.2. Test results
- Remark concerning extension : ~~The ESA has been tested according the amendments mentioned in Appendix 0.~~
~~The actual measurement test of the ESA was not re-quired.~~
~~The test result of the previous test are still valid.~~
- 2.2.1. General requirements : The requirements of the standards are met
- 2.2.2. Test results – radiated narrowband electromagnetic emissions : The requirements of the standards are met (Test data see Appendix 1)
- 2.2.3. Test results – radiated broadband electromagnetic emissions : The requirements of the standards are met (Test data see Appendix 1)
- 2.2.4. Test results – Immunity to electromagnetic radiation : The requirements of the standards are met (Test data see Appendix 1)
- 2.2.5. Test results – conducted Emission : The requirements of the standards are met (Test data see Appendix 1)
- 2.2.6. Test results – immunity to conducted transients : The requirements of the standards are met (Test data see Appendix 1)
- 2.3. Additional information
- The results of the test refer exclusively to the object(s) mentioned under point 1.1. of this report.
- Test site : Zhejiang ATTC Automobile Technology Service Co., Ltd.
 Area 5, 1/F, No 7, Building 008, No.1177, Lingyun Road,
 Ningbo National Hi-Tech Industrial Development Zone,
 Zhejiang Province, China (PRC)
- Test date : November 16, 2018
- 2.4. Remarks : Not applicable

Type : 60xxx Series
Manufacturer : SecoRüt Kfz Electronic GmbH

3. List of Appendices

Appendix L	: Technical information about the electrical/electronic sub-assembly (ESA) according to Annex 3B of the communication concerning the UN-type approval
Appendix 0	: List of modifications
Appendix 1	: Test protocol
Information document	: 60xxx Series-00 (13 pages)

4. Statement of conformity

The in point 0.5. mentioned information folder and the type described in that comply with the requirements mentioned on page 1.

With regard to the required level of performance to be achieved, the tested items were representative for the type to be approved (see point 1.2).

The mentioned test results refer to the vehicle(s)/object(s) described under point 1.1 of this report.

Engineering Centre Shanghai / January 14, 2019
DG/LS



Daniel Gu
Expert Technical Service

Type : 60xxx Series
 Manufacturer : SecoRüt Kfz Electronic GmbH

**Technical information about the electrical/electronic sub-assembly⁽¹⁾
 according to Annex 3B of the communication concerning the UN-type approval**

Appendix L

1. Make (trade name of manufacturer) : SecoRüt
2. Type and general commercial description(s) : 60xxx Series (Voltage Reducer)
3. Means of identification of type, if marked on the vehicle/component/
~~separate technical unit~~⁽¹⁾ : Label stick on the housing of product 60xxx Series
- 3.1. Location of that marking : Refer to page 5 of information folder
4. Category of vehicle : Not applicable
5. Name and address of manufacturer : SecoRüt Kfz Electronic GmbH
 Obere Dorfstrasse 56 34355 Staufenberg,
 Germany
6. In the case of components and separate technical units, location and method of affixing of the approval mark : Moulded on housing of product 60xxx Series
7. Address(es) of assembly plant(s) : Obere Dorfstrasse 56 34355 Staufenberg,
 Germany
8. Additional information (where applicable) : See Appendix below
9. Technical Service responsible for carrying out the tests : TÜV Rheinland Luxemburg GmbH
 2a, Kalchesbruck
 L-1852 Luxemburg
10. Date of test report : January 14, 2019
11. Number of test report : 87-R10-0252/19-00
12. Remarks (if any) : See Appendix below
16. The index to the information package lodged with the Approval authority, which may be obtained on request, is attached : Not applicable
17. Reasons for extension : Not applicable

Type : 60xxx Series
 Manufacturer : SecoRüt Kfz Electronic GmbH

**Appendix to type-approval communication form No. E13*10R05/01*xxxx*00
 concerning the type-approval of an electrical/electronic sub-assembly under Regulation No. 10.**

1. Additional information
 - 1.1. Electrical system rated voltage : 24V~~pos./neg.~~/neg. ground⁽¹⁾
 - 1.2. This ESA can be used on any vehicle type with the following restrictions : All vehicles with 24V respectively electrical wiring and battery at the body
 - 1.2.1. Installation conditions, if any : Connected to the battery of the vehicle
 - 1.3. This ESA can be used only on the following vehicle types : Not applicable
 - 1.3.1. Installation conditions, if any : Not applicable
 - 1.4. The specific test method(s) used and the frequency ranges covered to determine immunity were : ISO 11452-4, Third edition 2005 and Corrigendum 1:2009
 Bulk current injection testing method (from 20 to 400MHz)
 ISO 11452-2 2nd edition: 2004
 Free field testing method (from 400 MHz to 2000MHz)
 - 1.5. Laboratory accredited to ISO 17025 and recognized by the Approval Authority responsible for carrying out the tests : Not applicable
2. Remarks : Not applicable

⁽¹⁾ Strike out what does not apply.

Type : 60xxx Series
Manufacturer : SecoRüt Kfz Electronic GmbH

List of modifications

Appendix 0

Correction of : ---

Modification of : ---

Addition of : ---

Deletion of : ---

Type : 60xxx Series
Manufacturer : SecoRüt Kfz Electronic GmbH

Test protocol

Appendix 1

Test object

Trade name : SecoRüt
Type(s) /variant(s) /version(s) : 60xxx Series/---/60185

Technical data of the tested ESA type

Electrical system rated voltage : 24V DC, negative ground

This ESA can be used on any vehicle type with the following restrictions : All vehicles with 24V respectively electrical wiring and battery at the body

Installation conditions : Connected to the battery of the vehicle

This ESA can be used on the following vehicle types : Not applicable

Installation conditions : Not applicable

Type : 60xxx Series
 Manufacturer : SecoRüt Kfz Electronic GmbH

Test results

1. Radiated narrowband / broadband electromagnetic emissions:

Radiated broadband electromagnetic emissions : as shown in table 1

Radiated narrowband electromagnetic emissions : as shown in table 2

Antenna position : horizontal and vertical

Rated voltage : DC 24V

Maximum broadband QP value (table 1):

Frequency (MHz)	Test results (dB μ V/m)		Reference QP Limit (dB μ V/m)	Margin to QP reference value (dB μ V/m)
	hor.	vert.		
957.76	16.26	---	63.00	46.74
907.68	---	16.44	63.00	46.56

Maximum narrowband AV value (table 2):

Frequency (MHz)	Test results (dB μ V/m)		Reference AV Limit (dB μ V/m)	Margin to reference value (dB μ V/m)
	hor.	vert.		
955.88	10.10	---	53.00	42.90
911.92	---	9.95	53.00	43.05

Type : 60xxx Series
 Manufacturer : SecoRüt Kfz Electronic GmbH

Horizontal Polarity Test Result Diagram (Broadband and Narrowband)

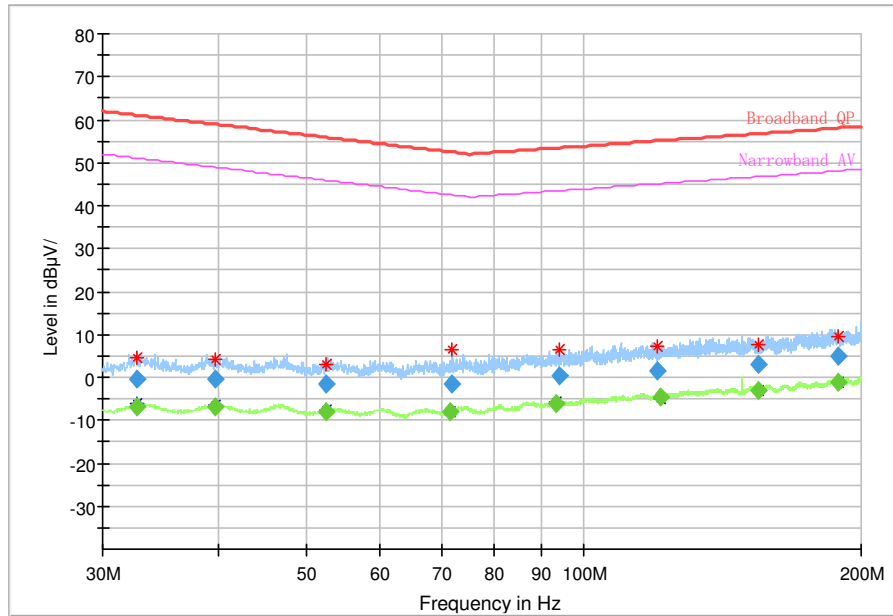

— Preview Result 2-AVG — Preview Result 1-PK+ * Critical_Freqs AVG
* Critical_Freqs PK+ — Broadband QP * Narrowband AV
◆ Final_Result QPK ◆ Final_Result AVG

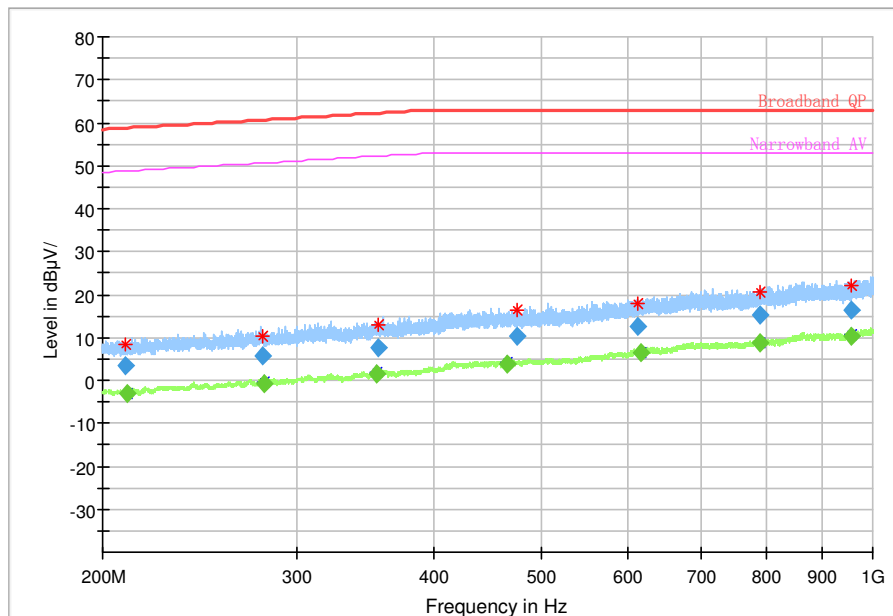

— Preview Result 2-AVG — Preview Result 1-PK+ * Critical_Freqs AVG
* Critical_Freqs PK+ — Broadband QP * Narrowband AV
◆ Final_Result QPK ◆ Final_Result AVG

Remark:

The blue scanning beam is QP value for broadband; the green scanning beam is AV value for narrowband

Type : 60xxx Series
 Manufacturer : SecoRüt Kfz Electronic GmbH

Vertical Polarity Test Result Diagram (Broadband and Narrowband)

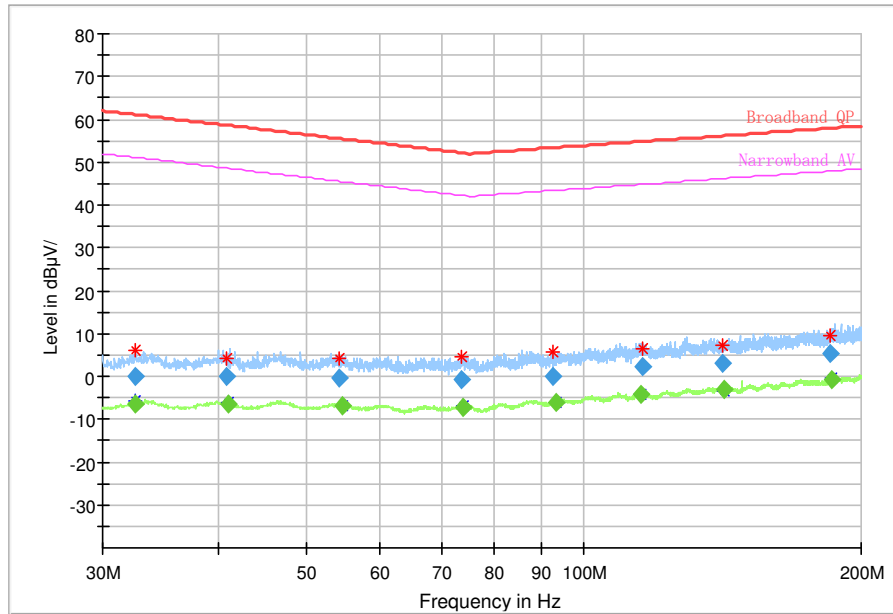

◆ Preview Result 2-AVG — Preview Result 1-PK+ * Critical_Freqs AVG
* Critical_Freqs PK+ — Broadband QP — Narrowband AV
◆ Final_Result QPK ◆ Final_Result AVG

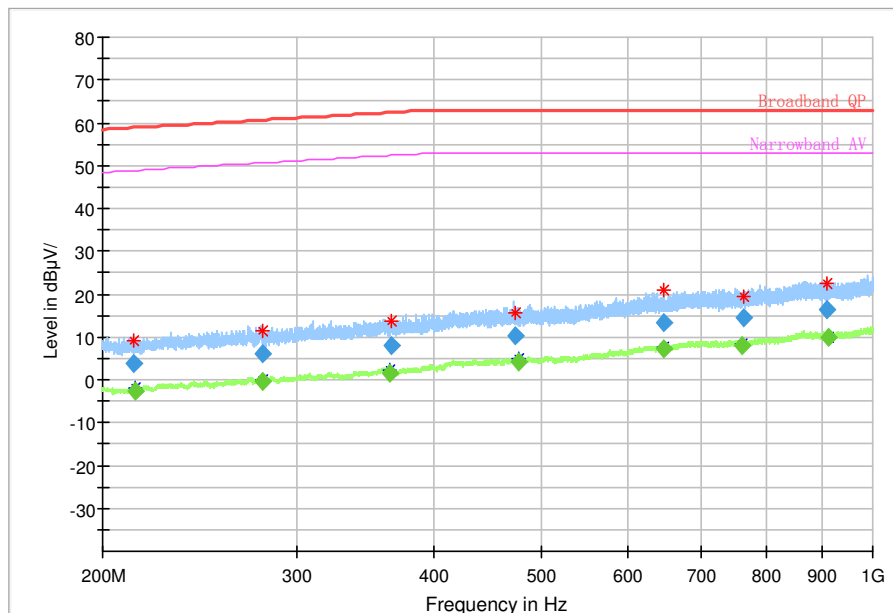

◆ Preview Result 2-AVG — Preview Result 1-PK+ * Critical_Freqs AVG
* Critical_Freqs PK+ — Broadband QP — Narrowband AV
◆ Final_Result QPK ◆ Final_Result AVG

Remark:

The blue scanning beam is QP value for broadband; the green scanning beam is AV value for narrowband

Type : 60xxx Series
 Manufacturer : SecoRüt Kfz Electronic GmbH

2. Conducted emissions

Test method : ISO 7637-2 2nd edition: 2004

Polarity of pulse amplitude	Maximum allowed value for vehicles with 24V systems		Measured Pulse amplitude True value
Positive	+ 150	FAST	+48.00V
		SLOW	+47.60V
Negative	- 450	FAST	-1.40V
		SLOW	-1.20V

3. Immunity to electromagnetic radiation

Test method : ISO 11452-4, Third edition 2005 and Corrigendum 1:2009
 Bulk current injection testing method (from 20 to 400MHz)

ISO 11452-2 2nd edition: 2004
 Free field testing method (from 400 MHz to 2000MHz)

Measurement result:

Frequency range (MHz)	Test level	Type of modulation	Test distance	Antenna position	Result
20~400	60mA	AM, 80%	150mm	/	Passed*
400~800	30volts/m	AM, 80%	1 m	Vertical	Passed*
800~2000	30volts/m	PM, 577µs	1 m	Vertical	Passed*

Remark:

* no degradation of performance of 'immunity-related functions'.

Type : 60xxx Series
 Manufacturer : SecoRüt Kfz Electronic GmbH

4. Immunity to transient disturbances

Test method : ISO 7637-2 2nd edition: 2004

Measurement result:

24V system

Test pulse	Test level	Number of pulse / test time	Burst cycle / pulse repetition time	Required minimum function status*	Status of function true value	Result
1	-450V	5000 pulses	0.5s	C	C	Passed
2a	37V	5000 pulses	0.2s	B	A	Passed
2b	20V	10 pulses	0.5s	C	C	Passed
3a	-150V	1 h	90ms	A	A	Passed
3b	150V	1 h	90ms	A	A	Passed
4	-12V	1 pulse	N/A	C	B	Passed

Remark:

* Class A: all functions of a device/system perform as designed during and after exposure to disturbance.

Class B: all functions of a device/system perform as designed during exposure. However, one or more of them can go beyond specified tolerance. All functions return automatically to within normal limits after exposure is removed. Memory functions shall remain class A.

Class C: one or more functions of a device/system do not perform as designed during exposure but return automatically to normal operation after exposure is removed.

Class D: one or more functions of a device/system do not perform as designed during exposure and do not return to normal operation until exposure is removed and the device/system is reset by simple "operator/use" action.

Class E: one or more functions of a device/system do not perform as designed during and after exposure and cannot be returned to proper operation without repairing or replacing the device/system.

	<p>INFORMATION DOCUMENT NO. 60xxx Series-00</p> <p>FOR TYPE APPROVAL OF AN ELECTRIC/ELECTRONIC SUB-ASSEMBLY WITH RESPECT TO ELECTROMAGNETIC COMPATIBILITY</p> <p>ACCORDING TO UN R10.05 ANNEX 2B</p>	<p>Page: 1</p>
<p>Application date: November 13, 2018</p>		

1. Make (trade name of manufacturer) : SecoRüt
2. Type : 60xxx Series
Variant(s) : Not applicable
Version(s) : 60185, 60180, 60181, 60183, 60186, 60191, 60192, 60193, 60194, 60195, 60197, 60226, 60228
3. Means of identification of type, if marked on the component/~~separate technical unit~~¹⁾ : Label stick on the housing of product 60xxx Series
- 3.1. Location of that marking : Refer to page 5
4. Name and address of manufacturer : SecoRüt Kfz Electronic GmbH
Obere Dorfstrasse 56 34355 Staufenberg,
Germany

Name and address of authorized representative, if any : Not applicable
5. In the case of components and separate technical units, location and method of affixing of the approval mark : Moulded on housing of product 60xxx Series (refer to page 5)
6. Address (es) of assembly plant(s) : Same as above item 4.
7. This ESA shall be approved as a component/~~STU~~
8. Any restrictions of use and conditions for fitting : All vehicles with 24V respectively electrical wiring and battery at the body
9. Electrical system rated voltage : DC 24V, negative ground

Appendix 1:

Description of the ESA chosen to represent the type electronic block diagram and list of main component constituting the ESA (e.g. make and type of microprocessor, crystal, etc.).

	<p>INFORMATION DOCUMENT NO. 60xxx Series-00</p> <p>FOR TYPE APPROVAL OF AN ELECTRIC/ELECTRONIC SUB-ASSEMBLY WITH RESPECT TO ELECTROMAGNETIC COMPATIBILITY</p> <p>ACCORDING TO UN R10.05 ANNEX 2B</p>	<p>Page: 2</p>
<p>Application date: November 13, 2018</p>		

Only applicable for charging systems:

- | | | |
|-----|---|------------------|
| 10. | Charger | : Not applicable |
| 11. | Charging current | : Not applicable |
| 12. | Maximal nominal current (in each mode if necessary) | : Not applicable |
| 13. | Nominal charging voltage | : Not applicable |
| 14. | Basic ESA interface functions | : Not applicable |
| 15. | Minimum Rsce value (see paragraph 7.11. of this Regulation) | : Not applicable |

List of contents

Appendix 1	Description of the ESA	page 3
Attachment 1	Photo of the ESA	page 4 - 6
Attachment 2	Electric Circuit Diagram	page 7 - 9
Attachment 3	Bill of Materials	page 10
Attachment 4	Statement of conformity	page 11-13

This information document consists of pages 1 to 13 including Appendix and Attachments.

	Appendix 1 to Information document no. 60xxx Series-00 Description of the ESA	Page: 3
--	--	---------

1. Input range : DC 23V ~ 29V, negative ground
2. Consumption power : 70 Watt
3. Resource of X-tal or oscillator : No
4. Main dimensions : 193 mm x 76mm x 68 mm
5. Weight : 386g
6. EMC countermeasure component : N.A.

Photo of the ESA

Front View



Position of
- Make

Rear View



Photo of the ESA

Side View



Position of
- Version designation



E-mark designation

Position of
- E-mark

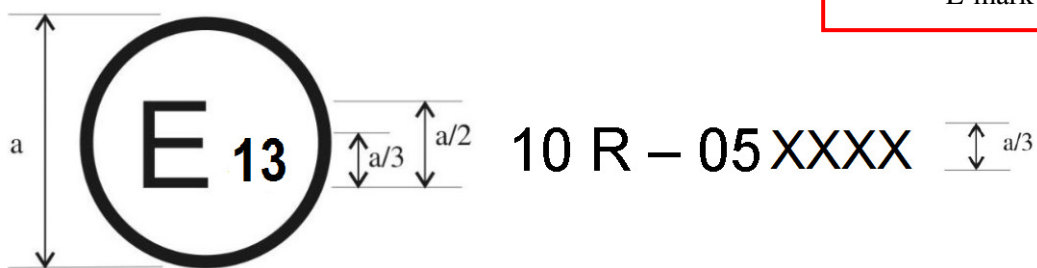

a = 6 mm

Photo of the ESA

Dimensional drawing

193 mm x 76mm x 68 mm

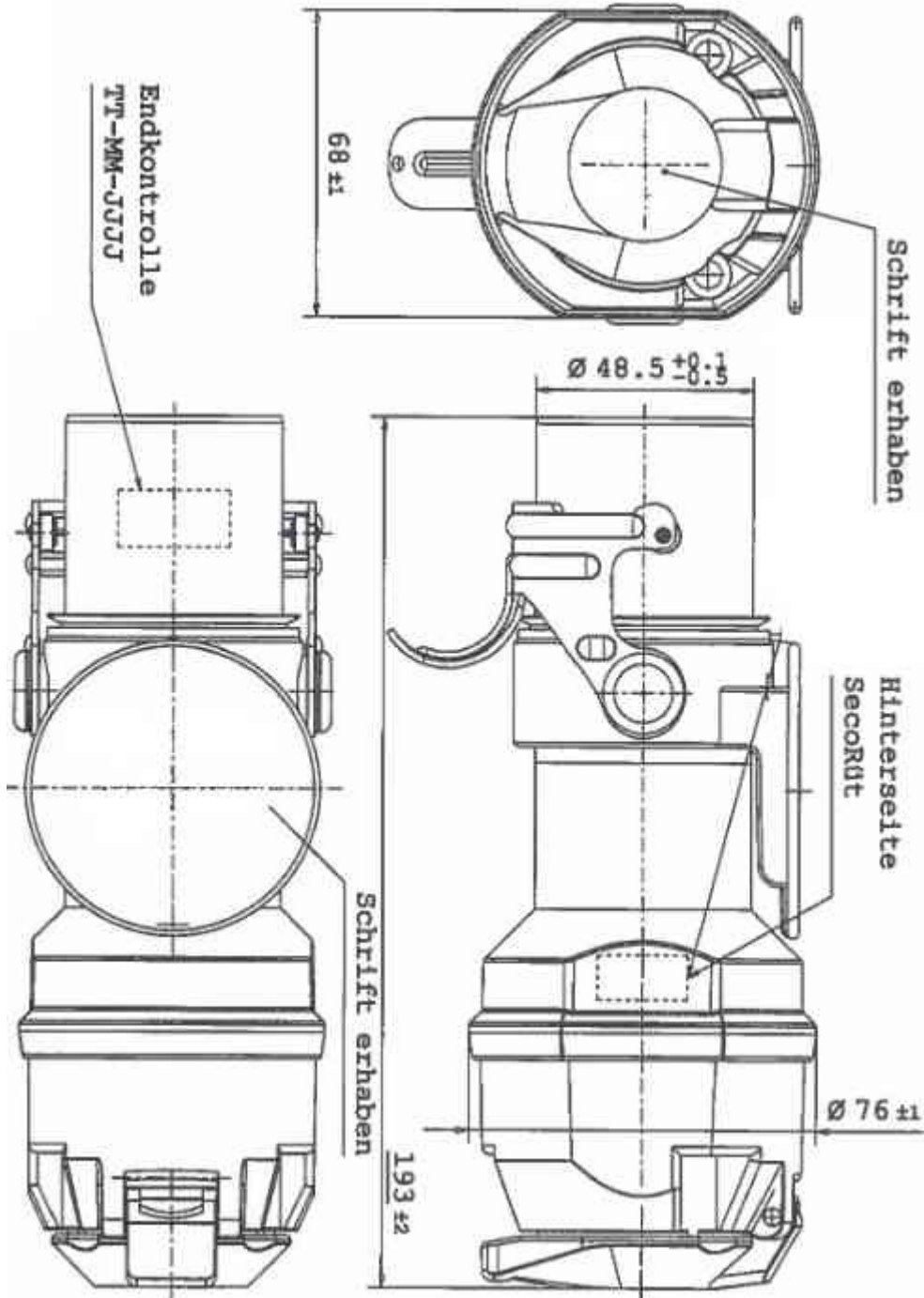

Electric Circuit Diagram

Front View of PCBA

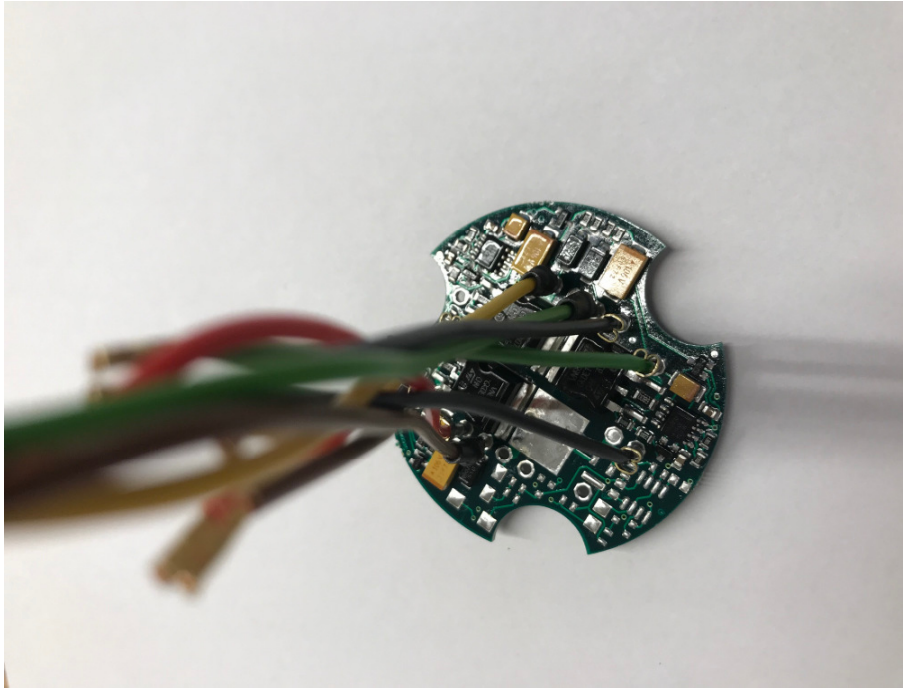

Rear View of PCBA

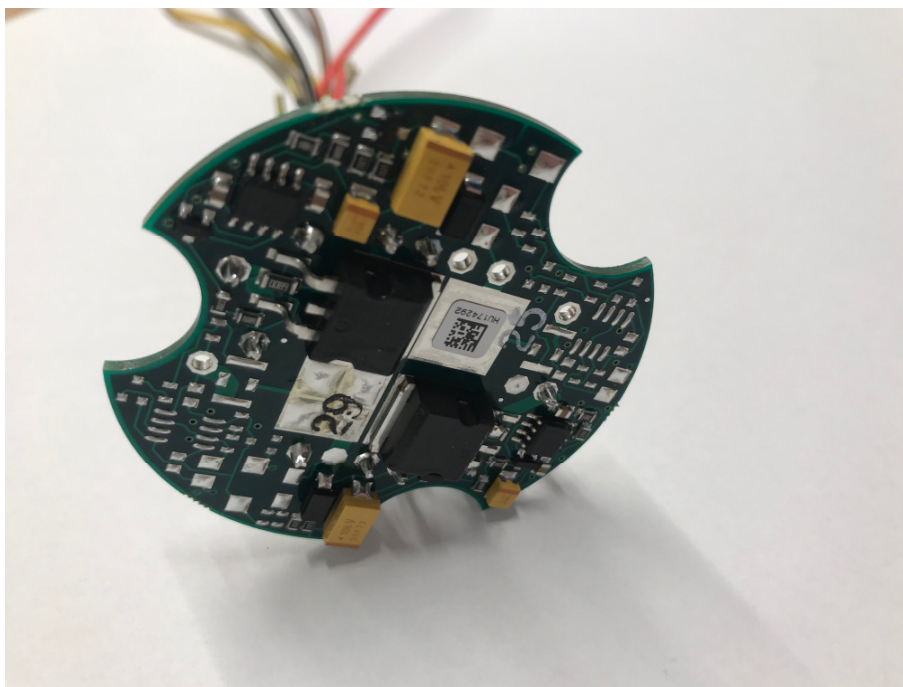

Electric Circuit Diagram

Side View of PCBA

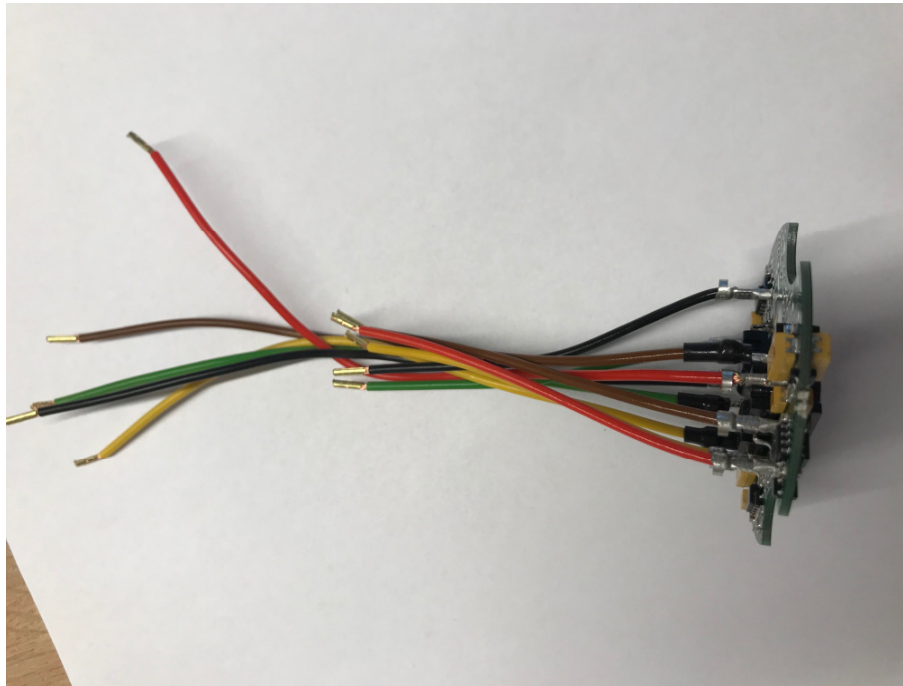

PIN No.	CIRCUIT	COLOUR
1	Left-hand turn	Yellow
2	Right-hand turn	Green
3	Rear Fog Light	Blue
4	Ground (Pins 1-3, 5-12)	White
5	Rear Lamps (L), Clearance & Side Marker Lamps	Black
6	Rear Lamps (R), Clearance & Side Marker Lamps	Brown
7	Stop Lamps	Red
8	Reversing Signal	Pink
9	Power Supply (Bat.+)	Orange
10	Brake Pad Sensor	Grey
11	Spring Loaded Brake Display	White/Black
12	Axle Lift	White/Blue
13	Ground (Pins 14 & 15)	White/Red
14	CAN Bus (High)	White/Green
15	CAN Bus (Low)	White/Brown



15 Pin Socket



15 Pin Plug

*Cable entry view

Electric Circuit Diagram

Electric Circuit Diagram

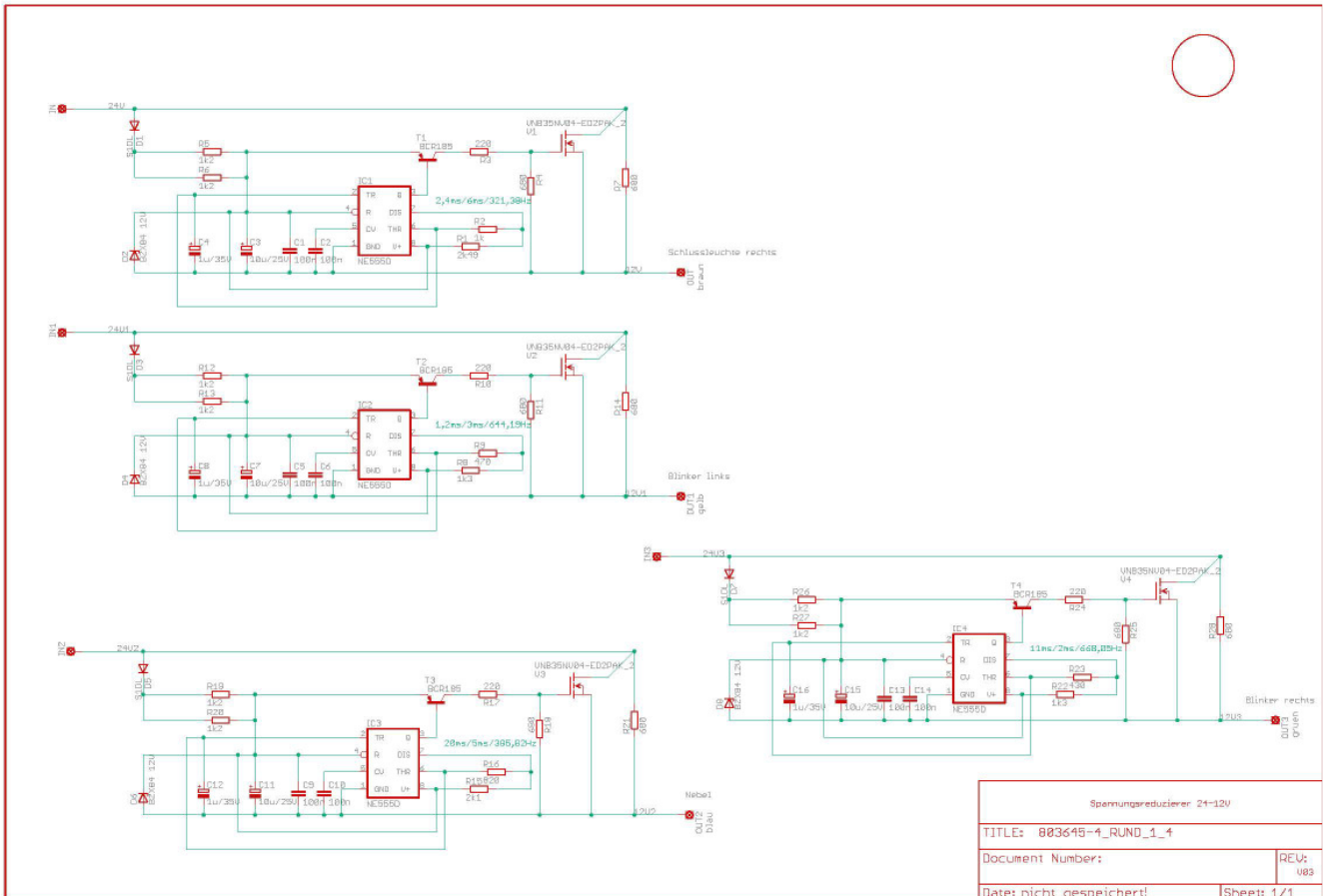

Bill of Materials

<i>BILL OF MATERIALS</i>				
No.	Symbol	Amount	Unit	Description
1	Capacitor	8	PCS	C1,C2,C5,C6,C9,C10,C13,C14 100n,C0805
2	Polarized capacitor	4	PCS	C3,C7,C11,C15 10u/25V,D/7343-31R
3	Resistor	8	PCS	R5,R6,R12,R13,R19,R20,R26,R27 1k2,R0805
4	Resistor	1	PCS	R1 2k49,R0805
5	Resistor	1	PCS	R15 2k1,R0805
6	Resistor	2	PCS	R8,R22 1k3,R0805
7	Polarized capacitor	4	PCS	C4,C8,C12,C16 1u/35v,B/3528-21R
8	Resistor	4	PCS	R3,R10,R17,R24 220,R0805
9	Resistor	4	PCS	R4,R11,R18,R25 680,R0805
10	Resistor	1	PCS	R2 1k,R0805
11	Resistor	1	PCS	R23 430,R0805
12	Resistor	1	PCS	R9 470,R0805
13	Resistor	1	PCS	R16 820,R0805
14	Resistor	4	PCS	R7,R14,R21,R28 680,R1206
15	PNR transistor	4	PCS	T1-T4 BCR185,SOT23-BEC
16	Z diode	4	PCS	D2,D4,D6,D8 BZX84 12V,TO236
17	Timer	4	PCS	IC1-IC4 NE555D,SO08
18	Diode	4	PCS	D1,D3,D5,D7 S1DL,SMB
19	N MOS	4	PCS	V1-V4 VNB35NV04-ED2AK_2

Statement of conformity

We hereby declare that the IC and wire used in all versions 60xxx series are same as model 60185, which are all from 24 volt to 12 volt. The only difference between them is the shape. Here are a table on the discrepancies between 60xxx series and the pictures of 60185, 60180, 60181, 60183, 60186, 60191, 60192, 60193, 60194, 60195, 60197, 60226, 60228.

Version	short text	Difference
60180	Voltage reducer	7 pol. 24 Volt to 7 pol. 12 Volt
60181	Voltage reducer 24-12 Volt	7 pol. 24 Volt to 13 pol. 12 Volt
60183	Voltage reducer 24-12 Volt	13 pol. 24 Volt to 13 pol. 12 Volt
60185	Voltage reducer 24-12 Volt	15 pol. 24 Volt to 13 pol. 12 Volt
60186	Voltage reducer 24-12 Volt	15 pol. 24 Volt to 7 pol. 12 Volt
60191	Voltage reducer 24-12 Volt 13 to 7 pin. Mercedes	13 pol. 24 Volt to 7 pol. 12 Volt
60192	Voltage reducer Nato 24 V - 7 pol 12 Volt	Nato 12 pol. 24 Volt to 7 pol. 12 Volt
60193	Voltage reducer 24 to 12 Volt for Nato	Nato 12 pol. 24 Volt to 13 pol. 12 Volt
60194	Voltage reducer 24-12 Volt 13 to 13 pin. Mercedes	13 pol. 24 Volt to 7 pol. 12 Volt
60195	Voltage reducer	7 pol. 24 Volt to 7 pol. 12 Volt
60197	Voltage reducer	7 pol. 24 Volt to 13 pol. 12 Volt
60226	Voltage reducer	24 Volt to 12 Volt
60228	Voltage reducer	24 Volt to 12 Volt

60180



60185



60181



60186



60183



60191



60192



60193



60195



60197



60194



60226



60228



Sincerely,

Responsible person

KFZ Electronic GmbH
Obere Dorfstr. 35 • 91074 Gumburg
www.secoruet.de • info@secoruet.de

Name: Mr. Tino Rüttgerodt/ CEO

SecoRüt Kfz Elelectronic GmbH