

Rutland 914i Windcharger

(12 or 24 V)

Owners Manual

Installation and Operation



GB, FR, ES & DE Languages

Contents	Page:
Introduction	4
Summary of Features and Uses	4
Profile and Dimensions	4
General Guidelines and Warnings	5
Check You Have Received	6
Other Items	7
Exploded View of the Rutland 914i	7
Assembly & Installation	
Twelve Step Quick Start Guide	8
Tower Preparation	9
Blade Assembly	9
Tail and Nose Assembly	10
Electrical Connection & Fitting to the Tower	11
Up & Running	
Four Point Checklist	11
Typical Wiring Diagrams for the Rutland 914i Windcharger	12
Siting the Windcharger	
General Considerations	13
Mounting The Windcharger	
On Board Systems	14
Land Based Systems	15
Further System Requirements	
Batteries	16
Cable Specifications	16
Specification & Performance	
Guideline Performance Curve	17
Maintenance & Troubleshooting	
Inspection & Maintenance	18
Troubleshooting	19
Installation Instructions (abbreviated) - French	21
Installation Instructions (abbreviated) - Spanish	24
Installation Instructions (abbreviated) - German	27
For Your Records	30
Limited Warranty	31

Introduction

Congratulations and thank you for purchasing your Rutland 914i Windcharger. The utmost of care goes into the manufacture of all our products in our ISO9001 approved factory. To ensure you get the very best out of the Rutland 914i we recommend that you read this manual and familiarise yourself with its contents before installing and operating the Windcharger system.

Summary of Features and Uses

- Aerodynamically improved to maintain good wind flow and stability.
- Maximum power point tracking technology yields up to 30% more power than the Rutland 913.
- Low wind speed start up maximises power generation in low winds.
- High grade construction materials for durability, U.V. stability and weather resistance.
- Provides a D.C. power supply to charge 12 or 24 V battery banks.
- Designed for use on board sailing yachts, motor caravans, static caravans and sites where low power is needed for domestic devices as well as navigation equipment etc.
- Note: There are other Rutland Windchargers designed for permanent installations on land - contact Marlec or visit www.marlec.co.uk to find out more.

Rutland 914i Profile & Dimensions

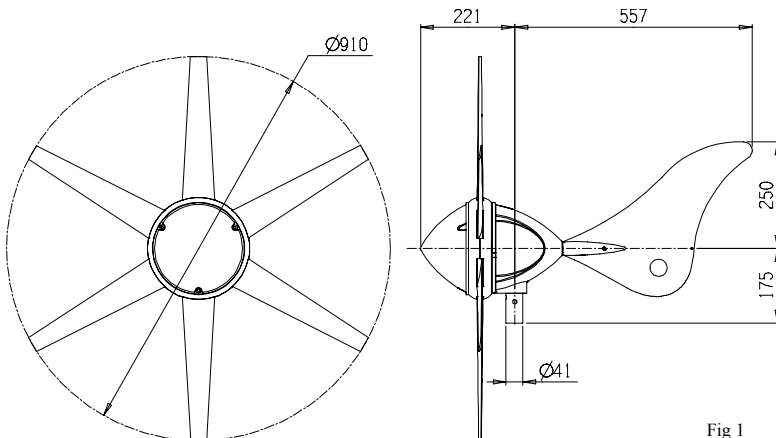

Fig 1

General Guidelines & Warnings

- *Mounting pole outside diameter MUST NOT exceed 48.5mm for at least the top 0.5m. Larger section poles must not be used as this will reduce the tower to blade clearance. In high wind conditions this could cause damage to the Windcharger by allowing the blade to come into contact with the mounting pole. A broken blade will cause turbine imbalance with consequent damage.*
- *When turning, the Windcharger is capable of generating voltages in excess of the nominal voltage. The turbine must never be allowed to rotate unless it is electrically connected to a regulator or batteries. Connecting an open circuit running turbine to the electrical system can cause serious damage to system components owing to excessive voltage. Caution must be exercised at all times to avoid electric shock.*
- *Stopping the turbine – this may be necessary to undertake battery maintenance. If possible stopping the turbine should be done in low wind speed conditions. The turbine can be slowed by rotating or orienting the tail fin upwind, this will slow the turbine sufficiently for it to be safely secured to the pole with rope. Avoid leaving the turbine tied up for any period of time, we recommend that the turbine either be covered to give protection from the weather or removed and stored in a dry location. We recommend the use of Marlec charge regulator that includes a shutdown switch.*
- *Choose a calm day to install the equipment and consider other safety aspects. No attempt to repair the system should be made until the wind generators restrained from turning.*
- *The Windcharger is fitted with ceramic magnets, which can be damaged by heavy handling. The main generator assembly should be treated with care during transit and assembly.*
- *It is essential to observe the correct polarity when connecting the Windcharger and all other components into an electrical circuit. Reverse connection will damage the Windcharger and incorrect installation will invalidate the warranty.*

- *The fuse supplied must be fitted to protect the system.*
- *The Rutland 914i Windcharger is suitable for sailing boats and some land based applications. When storm winds are forecast the turbine can be restrained to minimise wear and tear particularly when installed on land based applications where Furlmatic model windchargers are normally recommended. Note that where the manufacturer recommends a furling type windcharger should have been used the warranty is invalidated in cases of storm damage.*
- *If in doubt, refer to your dealer, a competent electrical engineer or the manufacturer.*

Check You Have Received - See Rutland 914i Exploded View

- 24 x No.10x25mm special self-tapping screws for aerofoil blades
- 1 x No.4 x 13mm self tapping screw for tail bracket covers
- 2 x M6 x 16mm hex. Head screws for tail fin
- 2 x M6 nylock nuts for tail fin
- 1 x fuse and fuse holder
- 1 x main generator assembly
- 6 x aerofoil blades
- 1 x tail fin
- 2 x tail bracket covers
- 1 x nose cone + 3 x nylon fixing screws
- 1 x 6mm Allen key
- 1 x 2-way terminal block
- 2 x M10 buttoncap screws
- 2 x shakeproof washers

In the event of loss or damage, consult your dealer or the manufacturer.

Other Items

What You Will Need - Tools

- Suitable wire stripper
- Small terminal screwdriver
- Large flat blade screwdriver
- Crosshead screwdriver
- 10mm Spanner or Socket

Other Items You Will Need

- Mounting pole
- Cable
- Batteries
- Battery terminals
- Connector blocks (as determined by your total system)

Other Items You May Have Selected

- HRS*i* or HRD*i* Charge Regulator
- Cable (usually 2.5mm² twin core - Part No: 902-015)
- Rutland 914*i* Marine Mounting Kit and Stays Kit (CA-12/02 & CA-12/32)
- Rutland 914*i* Land Tower & Rigging Kit (Part Nos: CA-12/08 & CA-12/07)
- Short section of stainless steel tube to adapt into your own mounting design.
- Voltmeter & Ammeter

Exploded View of The Rutland 914*i*

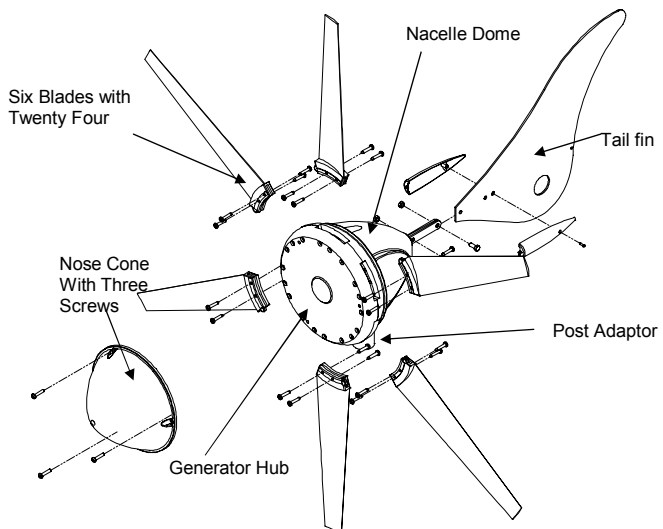

Assembly and Installation

Twelve Step Quick Start Guide

1. Choose an open site to expose the Windcharger to a clear flow of wind and avoiding obstructions. On board mount the Windcharger at least 2.4 metres above the deck and on land at least 4 - 6 m high. *Read the full section on **Siting**.*
2. Choose a mounting pole with an internal diameter of 41.0mm and external diameter of no greater than 48.5 mm for the top 0.6m minimum to (i) prevent accidental damage and (ii) meet warranty conditions.
3. Mount a charge regulator, from the Marlec range, to a suitable vertical surface and close to the battery. Follow instructions supplied with the charge regulator.
4. Drill the mounting pole, if required, in preparation to accept and secure the Windcharger. *See **Assembly and Installation** section.*
5. Choose suitable two core cable to connect from the Windcharger to the regulator. Up to 20m this should be of at least 2.5mm² cross sectional area. A short section of 4mm² cross sectional area is required to link the regulator to the battery. *For other distances see the table in **Cable Specifications**.*
6. Position the mounting pole (*this may be done on the ground before raising the pole*) so that the selected cable can be threaded along it.
7. Fit the blades, tail and nose to the Windcharger using fasteners provided. ***It is essential that 4 screws are fitted per blade.***
8. Join the cable threaded through the pole to the Windcharger output cable using the connector block provided. Wrap with insulating tape. Alternatively use a latching plug and socket. *We recommend looping back the cable and securing with a cable tie to provide strain relief to the joint.*
9. Carefully push the cables down the pole whilst sliding the post adaptor down the pole. Line up the holes and secure in place with the screws and washers provided. Tighten with the Allen key. ***Do not allow the turbine to spin freely.***
10. Locate the charge regulator close to the battery and carefully follow ALL the regulator guidelines and installation sequences for connecting the Windcharger through to the battery. *Note : Install the in-line fuse supplied with the Windcharger between the battery and charge regulator.*
11. Ensure that the battery connections are permanent as the Windcharger should NEVER be operated without a connection to the battery.
12. Raise and secure the Windcharger. It can now be allowed to rotate. Follow the “ **Up and Running- Four Points Final Checklist**” featured later. Also the “ **General Guidelines and Warnings**” section expands on the above points.

Assembly and Installation Detailed Instructions

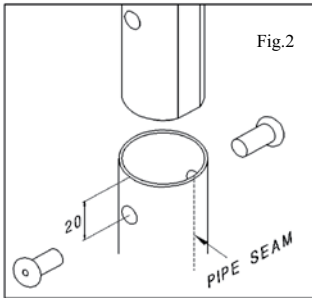

Tower Preparation (Fig.2)

Select a suitable pole from the suggested guidelines in Mounting the Windcharger. Note that the post adapter fitted to the 914i is designed to fit inside a standard 41mm (1 $\frac{5}{8}$ ") internal diameter tube.

The adapter is provided with a flat on one side to clear the weld seam on seamed pipe.

2. Mark and centre-punch two positions diametrically opposite, at 90° to the pipe seam if necessary, 20mm from top of the tube
Note: Use metric measurements for this operation
3. Drill two holes 10.5mm in diameter on centre-punch positions.
Note :Use metric measurements for this operation
Note: When using Rutland 914i Mounting Kit , items 2 and 3 can be ignored as Marlec supplied poles are pre-drilled.

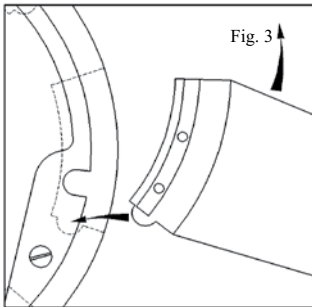

Blade Assembly (Fig.3)

1. Place the generator assembly on a flat surface hub-side down. Position blade as shown. **The blades will only fit one way around.**
2. Insert the protrusion at the trailing edge of the blade root fixing first into the socket to align with the corresponding recess in the blade socket. The blade can then be inserted with a lever action. A soft faced mallet may be used to tap the end of the blade to assist in fully locating the blade.
3. First fit each blade with two special self-tapping screws provided to the rear of each blade by inserting each in turn through the cut out in the nacelle, rotating the generator each time until the holes align. Fit the remaining blade screws from the front of the generator hub. Check tightness of all screws but do not over-tighten. **Caution- It is essential that all 4 screws are fitted!**

Alternatively the blades, tail and nose dome can be fitted after mounting the generator assembly to the tower.

Fitting The Tail and Nose Assembly (Fig.4)

1. Slide the tail fin between the two tail brackets lining up all drilled holes.
2. Locate the two screws provided through the appropriate holes and secure with nuts.
3. Locate the tail bracket covers into the nacelle grommet whilst positioning the processes for the fixing screw into the appropriate drilled hole in the tail.
4. Secure with the self tapping screw provided.

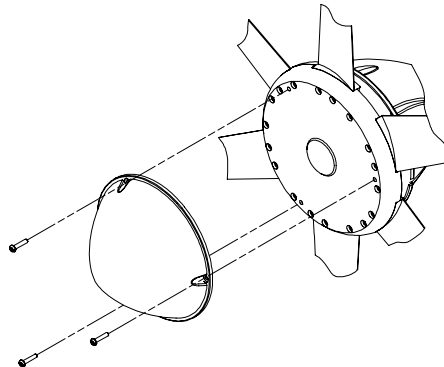
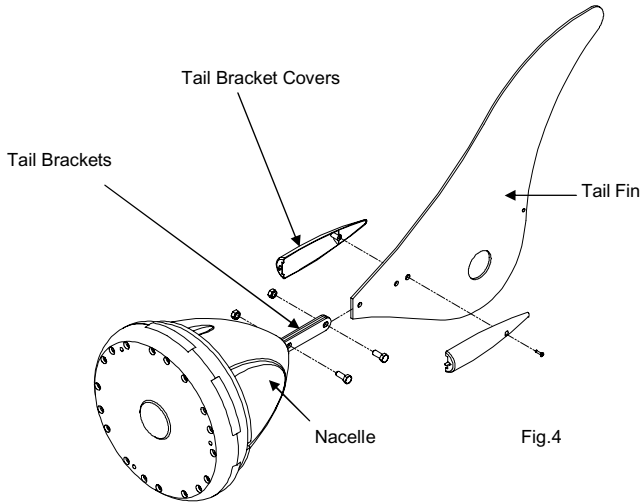

4. Fit the plastic nose dome in position on the front of the generator hub and secure in place with the three nylon screws provided.
5. You may now mount the Rutland 914i on to the tower if you have not already done so.

Electrical Connection and Fitting to The Tower

1. Run the cable selected (see Table 1) down the inside of the pole.
2. Select one of the 2 basic wiring systems on page 12 and follow the manual provided with the voltage controller.
3. Connect the wind generator flying leads to the cable protruding from the tower using the connector block supplied, taking care to observe polarity. Connect the Windcharger + to cable + and windcharger – to cable –

Red is + Positive
Black is - Negative

4. Wrap the connection with insulation tape to secure/protect from environment. Alternatively join the cables using a latching-type plug and socket.
5. Locate the wind generator into the tower whilst gently easing the cable from the tower base to ensure the cable is not trapped. Secure the wind generator to the tower using the button cap screws and shake proof washers provided, tighten using the 6mm Allen key provided.

Up and Running

Four Point Final Checklist

Before raising and securing the wind generator:

1. Check the tightness of the blade & tail fixing screws and generator mounting screws.
2. Check free rotation of the hub and yaw axis.
3. Check that the cable is not trapped.
4. Check that all electrical connections are secure and safe.

The wind generator can now be raised into position.

Take care to avoid all moving parts when raising and lowering the wind generator.

When raised, secure the structure firmly in an upright position.

Caution-The performance of your Windcharger will be impaired if the pole is not vertical.

Typical Wiring Diagrams For The Rutland 914i Windcharger

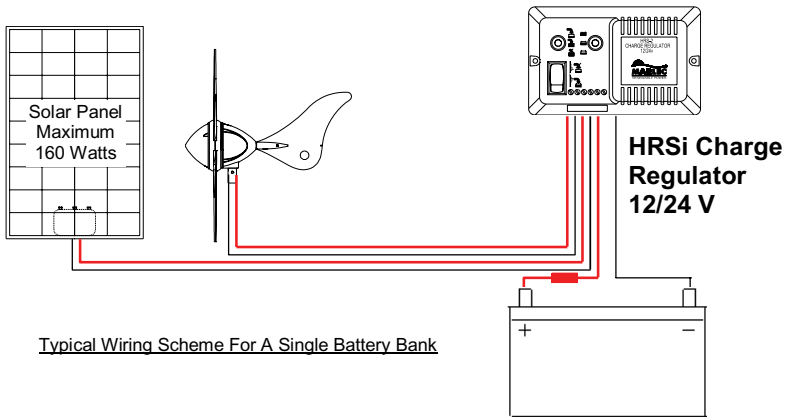

Typical Wiring Scheme For A Single Battery Bank

Typical Wiring Scheme For Single or Dual Battery Banks

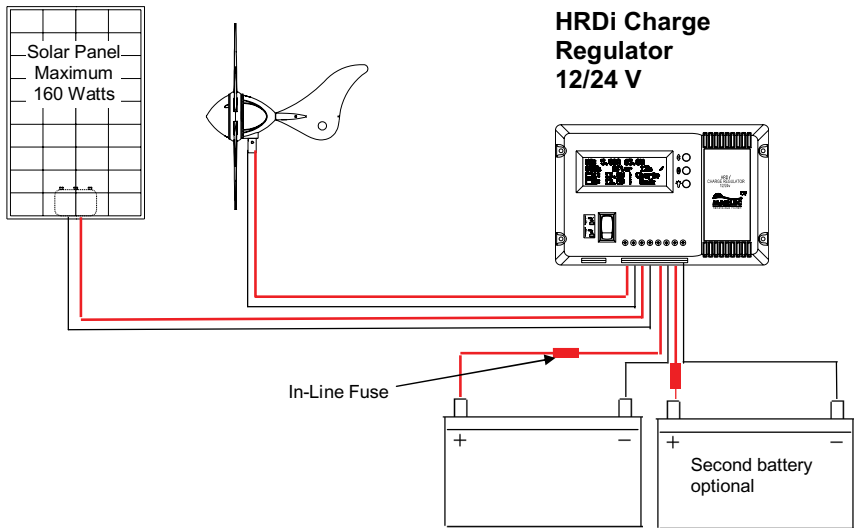

In-Line Fuse

Siting The Windcharger

General Considerations

The location and height of the mounting pole or tower for your wind turbine will be the major factor in the overall performance of your system. The smooth flow of wind over land and water is often interrupted by a multitude of obstructions causing wind shear and turbulence.

Wind shear describes the interference between the fast moving upper air and the slow moving air close to the ground and the resulting decrease in average wind speed as one gets closer to the ground.

Turbulence is caused by the wind passing over obstructions such as moored boats, trees, and buildings.

Both wind shear and turbulence diminish with height and can be overcome simply by putting the turbine sufficiently high above them as shown in Fig 4. Wind speed decreases and turbulence increases where obstructions exist. Consider also that downwind obstructions can be as detrimental to performance as upwind obstructions.

It is therefore essential that the wind generator should be located in an area as free as possible from disturbed wind flow.

Fig. 4

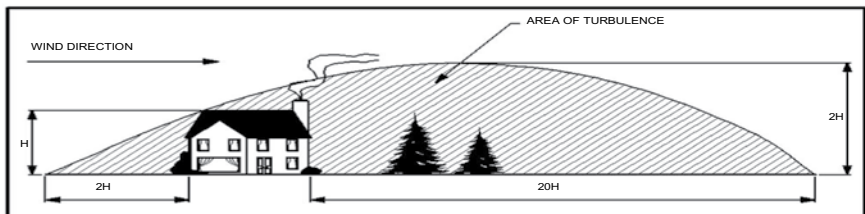

Mounting The Windcharger

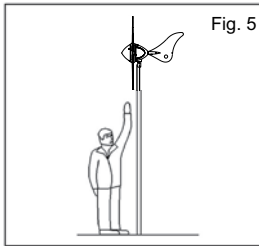

Fig. 5

On Board Systems

The wind generator should be mounted in a safe position, a minimum of 2.3 metres (7.6 feet) above the deck and away from other obstacles which could interfere with the blades or tail assembly (Fig. 5).

The Rutland 914i Mounting & Stays Kits (Part No. CA-12/02 & CA-12/32) are available for deck mounting, or short sections of stainless steel tube of 1200mm (47") and 600mm (23") pre-drilled are also available for your own fabrication.

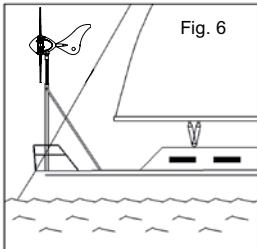

Fig. 6

The Rutland 914i is designed to fit inside an aluminium or stainless steel tube with an internal diameter of 41mm (1 $\frac{5}{8}$ "). **IMPORTANT:** The external diameter **MUST NOT** exceed 48.5mm (1 $\frac{7}{8}$), see Warning in Introduction.

Suitable tubes: Stainless Steel 1 $\frac{3}{4}$ "16 SWG and Aluminium 1 $\frac{7}{8}$ " 10 SWG

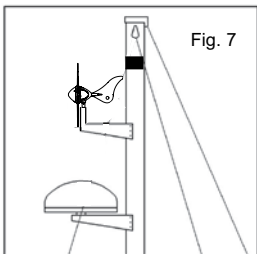

Fig. 7

We suggest the following mountings according to preference and site conditions:-

Push pit (Fig.6)

A suitable pole mounted to the deck with deck plates and solid guys is the most popular method of mounting the Windcharger on yachts, eg. Rutland 913 Mounting & Stays Kit.

Mizzen (Fig.7)

Mizzen mounting is suitable on larger yachts, taking advantage of greater wind flow the higher the wind turbine is mounted.

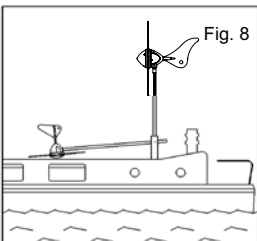
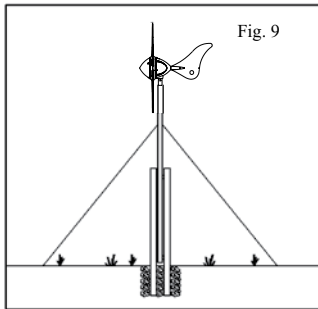

Fig. 8

River Boats (Fig.8)

A pivot pole is ideal for riverboats as the Windcharger can easily be raised and lowered.



Centre pivoted pole

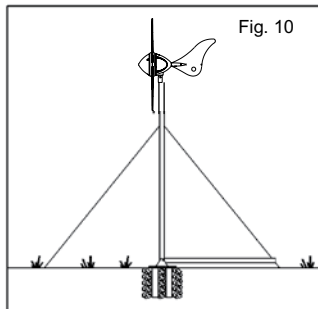

Base pivoted with gin pole

Land Based Systems

The Rutland 914i is suitable for some land based temporary and leisure applications. The Furlmatic Windcharger model is recommended for land based remote and exposed locations.

The Rutland 914i is designed to fit inside aluminium, stainless or steel tube with an internal diameter of 41mm. (1 $\frac{5}{8}$ "). **IMPORTANT:** The external diameter **MUST NOT** exceed 48.5mm (1 $\frac{7}{8}$), see Warning in Introduction.

A suitable mounting pole can be erected using a 6.5 metre (21 feet) galvanised (medium) tube. The tube must be supported by a minimum of four guy lines. The attachment points for the guy lines to the tower should be securely fixed to the tower.

- The guy wires should be a minimum of 4mm (0.16") in diameter.
- The shackles should be a minimum of 5mm (0.20") in diameter.
- Rigging screws should be a minimum of 5mm (0.20") in diameter.
- All items should be galvanised or stainless steel for protection against corrosion.
- Where guy lines are looped, the loop must incorporate a thimble and be fitted with a minimum of three rope grips.
- All ground fixings must be made suitable according to the terrain.

We suggest pivot type towers as these allow for easier installation and lowering for access to the wind generator. Two forms of pivot tower are suggested in Figs 9 & 10.

A base-hinged 6.4m tall Land Tower Kit (Part No: CA-12/08) and Rigging Kit (Part No:CA-12/07) are available from Marlec.

Further System Requirements

Batteries

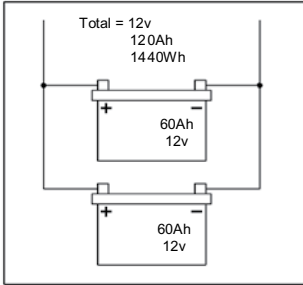

In parallel to increase amp

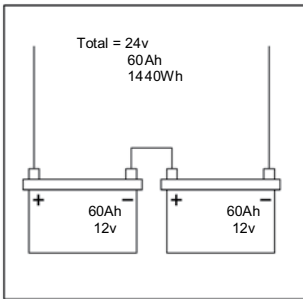

In series to increase voltage

Leisure/Deep Cycle batteries are specifically designed for good performance in terms of charge/discharge cycles. Batteries are the most important part of your battery charging system and should be sized according to your load requirements and provide at least 3 days reserve capacity. This will reduce cycling, prolong the life of the battery and ensure system reliability during periods of low wind.

Permanent connections should always be made to the battery terminals. Never use crocodile clips or similar devices.

We strongly recommend that one of the voltage regulators available from Marlec is fitted to prevent batteries becoming overcharged in strong winds and is essential with gel/sealed batteries.

Batteries may be linked as shown in the figures 10 and 11. It is essential to observe polarity as follows:

Red is + Positive
Black is - Negative

Cable Specification

Cable Run (m)	Cable Size			
	12V		24V	
	mm ²	AWG	mm ²	AWG
0-20	2.5	13	1.5	15
21-30	4	11	2.5	13
31-45	6	9	4	11
46-80	10	7	6	9

The cable used for connection of the Windcharger to the batteries should be in accordance with table 1. The use of a smaller cable than recommended will reduce the performance of the charging system.

Cable and connectors are available from your dealer or the manufacturer.

Specification and Performance

Guideline Performance Curve

Note : The curve shown below is for clear, non-turbulent wind conditions; this may not be achieved in some installations. Refer to the section on Siting to optimise performance at your site. Wind speeds are those flowing across the turbine of the Windcharger and may not reflect those measured at mast top or those reported by the Met. Office.

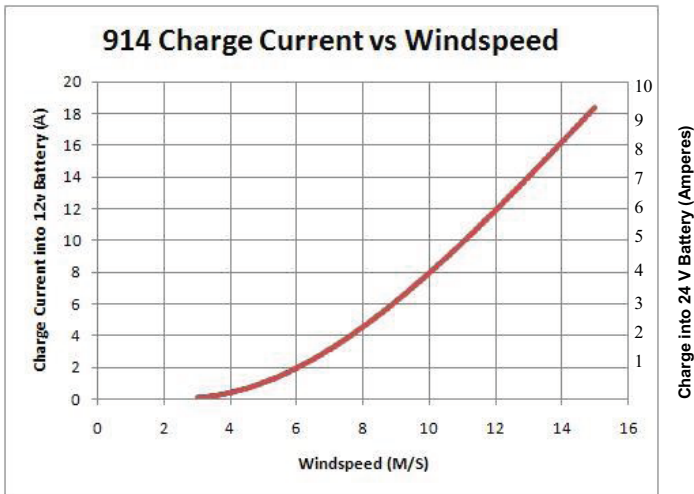

Maintenance and Troubleshooting

Inspection and Maintenance

The Rutland 914i requires no scheduled maintenance but an annual inspection should be carried out to monitor the general condition of the system to ensure the electrical and mechanical integrity and safety of the system.

WARNING! Before inspection, the turbine should either be lowered to the ground or tied to prevent the generator from turning. To stop the generator from turning proceed as follows:

1. Either rotate the switch to stall mode on the charge regulator if used OR turn the wind generator out of the wind (180°) using the tail, a hole is provided in the tail fin to assist in this. The generator will gradually slow down.
2. Tie a blade to the mounting pole to prevent it from rotating.

Whilst the generator is stationary, the following routine checks should be performed:

1. Check the blades for damage, eg chips or nicks. Replace any damaged blades. The turbine should not be operated with damaged blades as this may cause imbalance resulting in premature wear and possible failure. Check the blade screws for tightness.
2. Check all other nuts, bolts and screws for tightness.
3. Check the yaw axis for free rotation.
4. Check tower assembly for condition.
5. Check the tension of the guy wires if applicable. The tension of guy wires should be checked frequently during the first year.
6. The unit can be wiped with a mild detergent and rinsed with water to remove dirt and debris.

Note: The Windcharger is designed for continuous running to achieve maximum resistance to water ingress. Should you wish to take the unit out of service for an extended period it is recommend that the unit be removed from the mounting and stored in a dry location or covered.

Troubleshooting

In the unlikely event that your Rutland 914i should develop a defect, the turbine should first be tied to prevent the blades from turning to perform the static tests below. (Follow the procedure described in the Inspection and Maintenance section) It will be necessary to let it run for the tests to check for power production.

Read the Electrical Connection and Up and Running sections and be satisfied that your system complies.

Is there sufficient wind? The Rutland 914i needs 5 knots wind speed to start charging. The wind speed across the turbine blades may be greatly reduced in a marina or built-up area compared with the reading on a masthead anemometer or weather reports.

Static Tests:

Is the battery in good condition? Check the voltage and electrolyte level of each battery.

Check electrical continuity throughout the system, especially corrosion and poor connections in cable joins and connector blocks.

Running Tests:

Check for power output from the windcharger, following this procedure:

1. Set a digital multimeter to DC Amps, scale of between 5 and 10 if possible. Connect the meter positive (+) probe to the wind generator output positive cable and the meter negative (-) to the regulator input positive. Provided there is sufficient wind there should be a current reading. This establishes that power is being delivered.
2. Using the same multimeter setting as above measure between the regulator to battery + and the battery +. Provided there is sufficient wind there should be a current reading. This establishes if power is passing through the regulator.
3. If both above are unsuccessful set the multimeter to DC Volts. Disconnect the wind generator from the regulator and connect the meter + to the wind generator + and the meter - to the wind generator -. Provided there is sufficient wind there should be a variable voltage reading according to the speed of the wind seen at the wind turbine. This will establish if the wind generator is able to deliver power or not.
4. If tests 1 and 3 are successful but test 2 fails to produce results connect the wind generator directly to the battery. Set the digital multimeter to DC Amps and measure power between the wind generator + and the battery +. If a reading is measured, providing there is sufficient wind, then the regulator is faulty.

5. If the wind turbine fails to deliver any current or open circuit V reading undertake the further tests below.
6. Mechanical inspection. It may be necessary to remove the windcharger from its pole for the following tests.

Check the brushes and slipring for wear or damage. To inspect the brushes, remove the nacelle by removing the three fixing screws and slide the nacelle backwards towards the tail fin. The brushes and slipring can be inspected by removing the four self-tapping screws holding the brush holder assembly in place. Remove any black deposits from slipring with emery paper. Heavy deposits and reduced power indicate a possible reverse connection to the battery (see Page 10).

Check hub for free rotation with generator disconnected from battery.

If the hub does not rotate freely, check for a possible short circuit in the wiring. If no wiring fault is found refer to your dealer or manufacturer.

If the above checks have identified a need for spare parts or failed to identify the problem you should contact Marlec who can advise you of your nearest distributor in their world wide network. In the first instance we recommend that you contact the company from whom the product was originally purchased.

If in doubt, refer to your dealer or manufacturer.

Français

Introduction

Félicitations pour votre achat d'une éolienne Rutland 914i ! Comme tous nos produits, elle a été fabriquée avec le plus grand soin, dans notre usine certifiée ISO 9001. Pour obtenir pleine satisfaction de votre éolienne Rutland 914i, nous vous recommandons de lire entièrement ce manuel et de vous familiariser avec son contenu **avant** de commencer l'installation ou de l'utiliser.

Principales caractéristiques et applications

- Conception aérodynamique pour une bonne prise au vent.
- Tourne avec peu de vent pour optimiser les performances même par vent faible.
- Matériaux de qualité pour une durée de vie optimale, une bonne résistance aux UV et aux conditions climatiques.
- Permet de charger des batteries 12V ou 24V.
- Conçue pour fonctionner sur des bateaux, des camping-cars, des mobil-homes ou sur des sites où une faible puissance est nécessaire pour faire fonctionner des appareils ménagers, de l'instrumentation, etc. NB : il existe d'autres modèles d'éoliennes conçues pour une installation terrestre permanente. Venez les découvrir sur notre site www.marlec.co.uk

Informations générales et mises en garde

- Le diamètre externe du mât ne doit pas être supérieur à 48,5mm, au moins sur les 50 derniers centimètres. Ne pas utiliser de mât plus gros au risque de réduire le jeu nécessaire entre les pales et le mât. En cas de vents forts, les pales risquent de heurter le mât et de s'endommager. Une pale brisée provoque un déséquilibre capable d'entraîner des dégâts importants.
- Lorsqu'elle fonctionne, l'éolienne peut générer de l'électricité à haute tension, c'est pourquoi elle ne doit pas tourner tant qu'elle n'est pas reliée à un régulateur ou à des batteries. Raccorder directement l'éolienne à l'installation électrique peut provoquer des dégâts importants en raison de la surtension. Pour éviter tout risque d'électrochoc, vous devez être constamment vigilant.
- Stopper l'éolienne – Cela peut s'avérer nécessaire avant d'intervenir sur les batteries. Dans la mesure du possible, il est préférable de le faire lorsque le vent est faible. L'éolienne peut alors être ralentie en orientant l'aileron contre le vent ce qui permet de l'immobiliser en l'attachant au mât avec une corde. Éviter de l'immobiliser trop longtemps. Il est recommandé de la couvrir pour la protéger des effets du climat ou de la déposer pour l'entreposer en lieu sec. Le régulateur HRDX, vendu en option, est équipé d'un interrupteur Marche/Arrêt.
- Entre autres éléments de sécurité, effectuer l'installation par temps calme.
- Aucune tentative de réparation ne doit être engagée tant que l'éolienne n'est pas immobilisée.
- L'éolienne est équipée d'aimants céramiques qui peuvent facilement être abîmés lors de leur manipulation. Elle doit être maniée avec précaution durant le transport et le montage.
- Vents forts – Par vents forts, la sécurité thermique intégrée peut stopper l'éolienne pour l'empêcher de surchauffer. Dans ce cas, l'éolienne ne produit plus d'électricité et sa vitesse de rotation peut ralentir et d'augmenter, le temps nécessaire au refroidissement. Elle se remet automatiquement en marche lorsque la température a baissé. Si les vents forts persistent et plus particulièrement par temps chaud, vous verrez ces cycles se répéter. S'il vous est possible d'accéder à l'éolienne en toute sécurité, il est préférable de la bloquer temporairement.

- Il est essentiel de respecter les polarités lors du branchement de l'éolienne ainsi que de tous les autres composants du système électrique. Inverser les branchements endommagerait l'éolienne et une installation incorrecte annulerait la garantie.
- Le fusible fourni doit être installé pour protéger l'appareil.
- L'éolienne Rutland 914i est conçue pour une utilisation sur des bateaux à voiles ou certaines applications terrestres. Lorsque des vents d'orage sont annoncés, l'éolienne peut être immobilisée pour prévenir les risques d'usure et de casse, notamment lorsqu'elle est installée sur un site terrestre exposé aux vents forts pour lesquels il est recommandé d'utiliser des modèles Furlmatic (avec mise en drapeau automatique). Si ce type d'éolienne est recommandé par le constructeur pour une application, mais qu'il n'en est pas tenu compte, la garantie ne fonctionnera en cas de dommages occasionnés par des vents forts.

En cas de doute, se référer à votre revendeur, à un ingénieur compétent en électricité ou au fabricant.

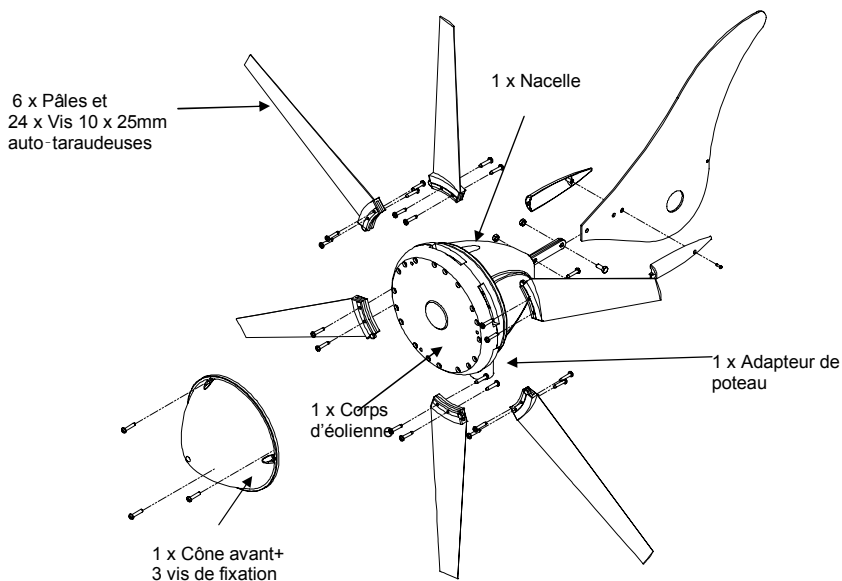

Guide d'installation en douze étape

1. Choisir un emplacement dégagé pour que l'éolienne soit exposée au vent sans aucune obstruction. A bord d'un bateau, la monter au minimum 2,5 m au-dessus du pont et sur terre à une hauteur de 4 à 6 m minimum. *Lire le chapitre « Choix de l'emplacement ».*
2. Prévoir un mât de 41 mm de diamètre intérieur et de 48,5 mm maximum de diamètre extérieur, au moins sur les 50 derniers centimètres, pour prévenir tout risque de dégâts et effectuer un montage conforme aux exigences de la garantie.
3. Monter un régulateur, choisi dans la gamme proposée par Marlec, sur un plan vertical et à proximité des batteries. Suivre les instructions de montage fournies avec le régulateur.
4. Le cas échéant, percer les trous de fixation sur le mât et fixer l'éolienne au mât. *Voir le chapitre « Assemblage et installation de l'éolienne ».*
5. Choisir un câble adéquat à deux conducteurs pour relier l'éolienne au régulateur. Jusqu'à 20 m de longueur, choisir un câble d'une section de 2,5 mm². Pour relier le régulateur à la batterie, un câble de 4 mm² est nécessaire. *Pour d'autres longueurs, se reporter au chapitre « Type de câble ».*
6. Passer le câble dans le mât (*cela peut se faire au sol, avant de dresser le mât*).
7. Fixer les pâles, l'aileron et le cône avant sur l'éolienne, à l'aide des fixations fournies. *Chaque pale doit être montée avec les quatre vis fournies.*
8. Utiliser le bloc de connexion fourni pour raccorder le câble passé dans le mât au câble sur l'éolienne. Protéger la connexion avec du ruban isolant. Vous pouvez aussi utiliser une prise *Nous recommandons d'effectuer une boucle et de la fixer afin de diminuer la contrainte sur la connexion.*
9. Pousser les câbles à l'intérieur du mât avec précaution, et poser l'adaptateur dans le mât. Aligner les trous de fixation et sécuriser le montage avec les rondelles et les vis fournies. Serrer en utilisant la clé Allen également fournie. *Empêcher la turbine de tourner à vide.*
10. Monter le régulateur à proximité de la batterie et suivre rigoureusement toutes les instructions ainsi que la séquence de branchements pour raccorder l'éolienne aux batteries. *NB : monter en ligne le fusible fourni avec l'éolienne entre le régulateur et la batterie.*
11. L'éolienne ne doit en aucun cas pouvoir fonctionner sans être raccordée à la batterie, s'assurer que la connexion soit permanente.
12. Dresser et fixer le mât. L'éolienne est maintenant prête à fonctionner. Effectuer les vérifications (en quatre points) indiquées au chapitre « *Dressage et mise en service de l'éolienne* ». Les « Informations générales et mises en garde » énoncées ci-dessus doivent également avoir été intégrées.

Español

Introducción

Felicitaciones y gracias por comprar un cargador eólico Rutland 914i. Utilizamos sumo cuidado en la fabricación de todos nuestros productos en nuestra fábrica aprobada por la Norma ISO9001. Para asegurarnos de que reciba lo mejor de nuestro Rutland 913, le recomendamos que lea este manual y se familiarice con su contenido antes de instalar y poner en funcionamiento el sistema del cargador eólico.

Resumen de características y usos

- estilo aerodinámico para mantener estabilidad y un buen flujo del viento
- el arranque con vientos a baja velocidad maximiza la producción de energía en vientos de poca fuerza
- materiales de construcción de gran calidad para mayor durabilidad, estabilidad U.V y resistencia a la intemperie
- proporciona una fuente de alimentación CC para cargar bancos de batería de 12 o 24 voltios.
- diseñado para ser utilizado a bordo de yates a vela, casillas rodantes motorizadas, casillas rodantes estáticas y sitios en donde se necesita una baja potencia para dispositivos domésticos como así también equipos de navegación, etc.
- Nota: Existen otros cargadores eólicos Rutland diseñados para instalaciones permanentes en tierra, para obtener mayor información, comuníquese con Marlec o visite la página Web www.marlec.co.uk.

Pautas y advertencias generales

- El diámetro externo del mástil de montaje NO DEBE exceder los 48,5 mm aunque sea en los 0,5m superiores. No utilice mástiles más grandes ya que esto reducirá el espacio entre la torre y la paleta. En condiciones de vientos fuertes, esto puede provocar daños al cargador eólico ya que la paleta entra en contacto con el mástil de montaje. Una paleta rota producirá un desequilibrio en la turbina y daños posteriores.
- Al girar, el cargador eólico es capaz de generar voltajes superiores al voltaje nominal. Nunca permita que la turbina gire a menos que se encuentre conectada eléctricamente a un regulador o a una batería. La conexión de una turbina que funciona con un circuito abierto al sistema eléctrico puede provocar daños graves a los componentes del sistema por el excesivo voltaje. En todo momento, tenga cuidado y evite las descargas eléctricas.
- Detención de la turbina: puede ser necesaria para realizar el mantenimiento de la batería. Si es posible, detenga la turbina en condiciones de viento a baja velocidad. Disminuya la velocidad de la turbina girando o dirigiendo la aleta de la cola contra el viento; esto disminuirá la velocidad de la turbina lo suficiente como para que ésta se pueda sujetar con una soga y sin peligro al mástil. Evite dejar la turbina atada durante mucho tiempo; le recomendamos que cubra la turbina para protegerla de la intemperie o retírela y guárdela en un lugar seco. Le recomendamos que utilice el regulador de carga Marlec que incluye un interruptor de desconexión.
- Elija un día sin viento para instalar el equipo y tenga en cuenta otros aspectos de seguridad.
- No intente reparar el sistema hasta que el generador de viento este sujeto y no pueda girar.
- El cargador eólico esta ajustado con imanes cerámicos que pueden dañarse durante una fuerte manipulación. Tenga cuidado con el ensamblaje del generador principal durante el transporte y el montaje.

- Vientos fuertes: durante vientos fuertes el termostato incorporado al cargador eólico puede ponerse en funcionamiento para evitar que el generador se recaliente. En este modo, la salida se detendrá y la turbina se desacelerará y acelerará temporalmente hasta alcanzar una temperatura menor y el generador se encuentra nuevamente conectado y cargando. Se lo puede ver girar durante prolongados vientos fuertes, particularmente en temperaturas ambientales elevadas. Si es accesible y seguro, quizás prefiera sujetar temporalmente la turbina.
- Es esencial respetar la polaridad correcta al conectar el cargador eólico y todos los demás componentes en un circuito eléctrico. Una conexión inversa dañará al cargador eólico y la instalación incorrecta anulará la garantía.
- Ajuste el fusible incluido para proteger el sistema.
- *El cargador Rutland 914i es apropiado para barcos de vela y algunas aplicaciones terrestres. Cuando se pronostica una tormenta de viento, se puede sujetar la turbina para minimizar el desgaste y daño particularmente cuando se encuentra instalada en aplicaciones terrestres en donde normalmente se recomiendan los modelos de cargadores eólicos Furlmatic. Tenga en cuenta que cuando el fabricante recomienda un cargador eólico plegable, la garantía se anulará en casos de daños por tormenta.*

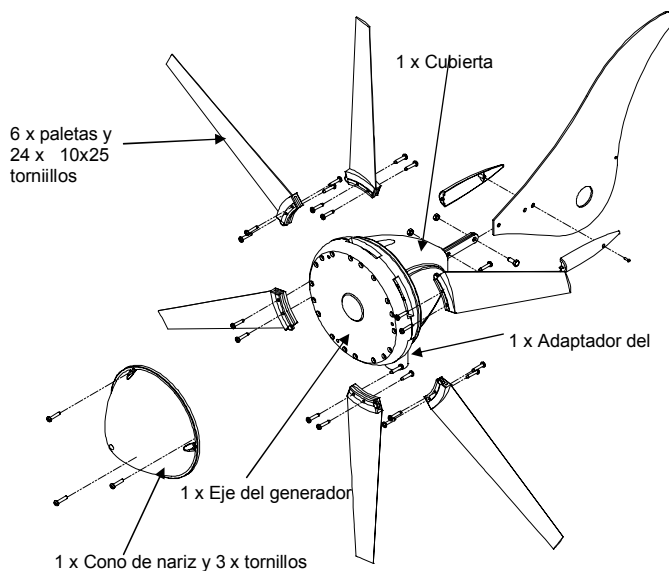

Guía rápida de inicio – 12 pasos

1. Elija un sitio abierto para exponer al cargador eólico a un flujo libre de viento y así evitar obstrucciones. A bordo, monte el cargador eólico por lo menos a 2,4 metros de la cubierta, en tierra por lo menos a 4 hasta 6 metros de altura. *Lea toda la sección de Instalación.*
2. Elija un mástil de montaje con un diámetro interno de 41 mm y un diámetro externo no mayor a 48,5 mm para los primeros 0,6 m como mínimo para (i) evitar daños accidentales y (ii) cumplir con las condiciones de la garantía.
3. Monte un regulador de carga, del rango Marlec, sobre una superficie vertical adecuada y cerca de la batería. Siga las instrucciones proporcionadas con el regulador de carga.
4. Perfore el mástil de montaje, en caso de ser necesario, para prepararlo para que tolere y sujete al cargador eólico. *Vea la sección Montaje e Instalación.*
5. Elija un cable de dos conductores adecuado para que el cargador eólico se conecte con el regulador. De hasta 20 m, éste debería ser un área de secciones de por lo menos 2,5 mm². Es necesaria una pequeña área de sección de 4 mm² para unir el regulador a la batería. *Para consultar otras distancias, vea la clasificación en Especificaciones para cables.*
6. Coloque el mástil de montaje (*esto puede hacerlo en el piso antes de levantar el mástil*) de tal manera que el cable seleccionado pueda enroscarse a lo largo del mismo.
7. Ajuste las paletas, la cola y la nariz del cargador eólico mediante los fijadores proporcionados. *Es esencial que ajuste 4 tornillos por paleta.*
8. Una el cable enroscado en el mástil al cable de salida del cargador eólico mediante el bloque conector proporcionado. Envuelva con cinta aisladora. O bien utilice un tapón o toma corriente con pestillo. *Le recomendamos enroscar el cable y asegurarlo con una cinta de sujeción para cables para aliviar la tensión en la junta*
9. Con cuidado presione los cables hacia el mástil mientras desliza el adaptador del mástil por el mismo. Alinee los orificios y sujételos en el lugar con los tornillos y arandelas proporcionadas. Apriete con la llave Allen. *No permita que la turbina gire libremente.*
10. Ubique el regulador de carga cerca de la batería y siga cuidadosamente TODAS las pautas y secuencias de instalación del regulador para conectar el cargador eólico a la batería. *Nota: instale el fusible en línea proporcionado con el cargador eólico entre la batería y el regulador de carga.*
11. Asegúrese de que las conexiones de la batería sean permanentes ya que el cargador eólico NUNCA debe ponerse en funcionamiento sin estar conectado a la batería.
12. Levante y sujete el cargador eólico. Ahora puede dejarlo que gire. Siga la “**Lista de control final de 4 puntos denominada: Instalado y en Funcionamiento**”, que se observa más adelante. También la sección “**Pautas y advertencias generales**” amplía sobre los puntos mencionados.

Deutsche

Einleitung

Wir gratulieren und bedanken uns für den Erwerb Ihres Rutland 914i Windchargers. Wir leisten die beste Sorgfalt bei der Herstellung von allen unseren Geräten gemäß dem anerkannten Betriebsstandard ISO9001. Zur Gewährleistung für alle Vorteile beim Gebrauch von Rutland 914i bitten wir Sie diese Anleitung vollständig durchzulesen, bevor Sie mit der Montage und Inbetriebnahme des Windchargers fortfahren.

Zusammenfassung der Funktionen und Anwendungen

- Aerodynamisch gestaltet für einen ausgezeichneten Luftstrom mit Luftstabilität.
- Das Anlassen bei einer niedrigen Windgeschwindigkeit maximiert Stromerzeugung bei geringen Windstärken.
- Hochwertige Baustoffe für Strapazierfähigkeit, UV-Strahlungsstabilität und Witterungsbeständigkeit.
- Der Wind Generator liefert eine Gleichstrom zum Aufladen eines 12 oder 24V Akku.
- Für die Nutzung auf Segeljachten an Bord, bei Reisemobilen, Wohnmobilen und für Standorte bestimmt, wobei ein geringer Stromverbrauch für Haushaltsgeräte und auch für Navigationsgeräte etc. erforderlich ist.
- Anmerkung: Für weitere Windcharger von Rutland, welche für die dauerhafte Montage an Ort und Stelle entworfen wurden, treten Sie bitte mit Marlec in Kontakt oder besuchen Sie www.marlec.co.uk für weitere Informationen.

Allgemeine Richtlinien & Gefahrenhinweise

- Die Mastmontage DARF den Außendurchmesser von 48.5mm, zumindest den Oberen von 0.5m NICHT überschreiten. Größere Mastquerschnitte dürfen nicht verwendet werden, da dies zu einer geringeren Distanz zwischen dem Mast und dem Rotorblattspiels führt. Bei hohen Windbedingungen könnte es beim Windcharger zu Schaden führen, da das Rotorblatt mit dem festmontierten Mast in Kontakt kommen könnte. Ein zerbrochenes Rotorblatt verursacht ein Ungleichgewicht der Turbine und dementsprechend Schäden.
- Bei der Drehbewegung ist der Windcharger in der Lage Stromspannungen höher als die Nennspannung zu erzeugen. Es darf nie zugelassen werden, dass die Turbine rotiert, es sei denn das sie elektrisch mit einem Aufladekontrollgerät oder mit Batterien angeschlossen ist. Der Anschluss einer laufenden Turbine im Leerlauf an das Elektrosystem kann ernsthafte Schäden bei den Anlagebestandteilen, aufgrund der überhöhten elektrischen Spannung hervorrufen. Vorsicht ist stets zu bewahren zur Vermeidung eines Stromschlages.
- Das Anhalten der Turbine – wird bei der Wartung der Batterie notwendig. Falls möglich sollte die Turbine bei Bedingungen mit niedrigen Windgeschwindigkeiten gestoppt werden. Die Turbine kann durch das Rotieren oder durch das windwärts legen der Heckschaukel des Rotorblattes abgebremst werden, das führt zu einem Anhalten der Turbine, sodass sie sicher mit einem Seil an den Mast befestigt werden kann. Vermeiden Sie, dass die Turbine für längere Zeit festgebunden bleibt, wir empfehlen stattdessen, dass die Turbine entweder abgedeckt wird, um sie gegen die Witterung zu schützen oder entfernt und in einem trockenen Raum gelagert wird. Wir empfehlen den Nutzen des Marlec Aufladekontrollgerätes mit einem integrierten Schalter zur Stromabschaltung.
- Wählen Sie einen windstillen Tag für die Montage der Anlage und beachten Sie dabei weitere Sicherheitsfaktoren.
- Es darf kein Reparaturversuch an der Anlage stattfinden, bis alle Drehbewegungen des Windgenerators gedrosselt sind.

- Der Windcharger ist mit einem Keramikmagnet ausgestattet, der bei einer schwerwiegenden Handhabung beschädigt werden kann. Der Hauptstromgenerator sollte mit Sorgfalt während dem Transport und der Montage behandelt werden.
- Hohe Windstärken – bei hohen Windstärken kann sich das eingebaute Thermostat des Windchargers in Betrieb setzen, um ein Überheizen des Stromgenerators zu verhindern. Während diesem Betriebszustand wird die Ausgabe des Stromgenerators beendet, das Tempo der Turbine wird sich zeitweise verlangsamen und beschleunigen bis zu diesem Zeitpunkt, wenn die niedrigen Temperaturwerte erreicht wurden, dann wird der Stromgenerator erneut angeschlossen und aufgeladen. Dies lässt sich möglicherweise in geschlossener Reihe bei langanhaltenden hohen Windstärken ersehen, insbesondere bei hohen Außentemperaturen. Falls ein Zugriff ohne Gefahr möglich ist, wird es bevorzugt die Turbine zeitweise abzusichern.
- Es ist notwendig die korrekte Polarität zu beachten, wenn der Windcharger und alle weiteren Bestandteile an den elektrischen Stromkreis angeschlossen werden. Ein Rückwärtsstrom wird den Windcharger beschädigen und eine inkorrekte Installation führt dazu, dass die Garantie gegenstandslos gemacht wird.
- Die mitgelieferte Sicherung muss zum Schutz des Gerätes angebracht werden.
- *Der Rutland 914i Windcharger eignet sich für Segelboote und für einige Anwendungen zu Land. Wenn Sturmwinde vorhergesagt werden, kann die Turbine gedrosselt werden, um einen Verschleiß und Abnutzen zu reduzieren, insbesondere wenn sie für Anwendungen zu Lande installiert wurde, wobei dafür normalerweise die Windcharger der Furlmatic Modelle empfohlen werden.*
- *Anmerkung, wenn es vom Hersteller empfohlen wurde, dass ein Windcharger der Furlmatic Modelle für jegliche Art von Segelvorrichtungen zu nutzen sei, wird die Garantie im Falle eines Sturmschadens gegenstandslos gemacht. Im Zweifelsfall wenden Sie sich bitte an Ihren Fachhändler, an einen fachkundigen Elektroingenieur oder an den Hersteller.*

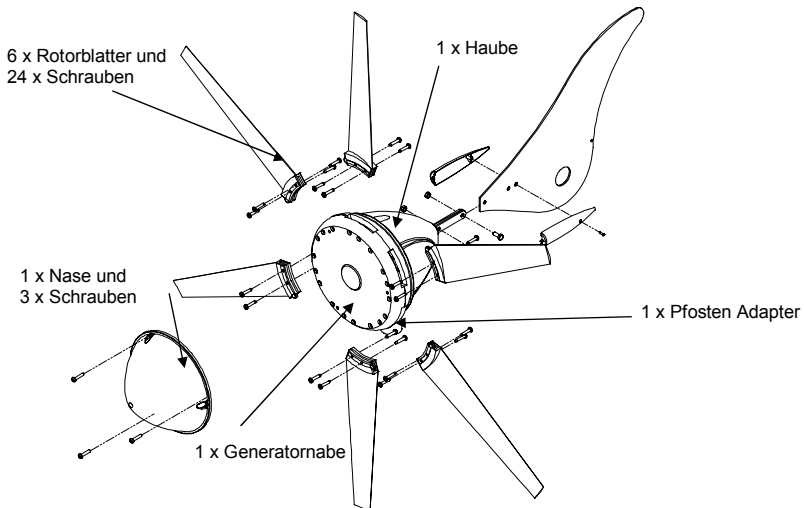

Kurzanleitung mit zwölf Anhaltspunkten

1. Wählen sie eine offene Stelle für die Montage Ihres Windchargers in einem bestimmten Luftstrom und unter der Vermeidung von Hindernissen. An Bord sollte der Windcharger mindestens 2.4 Meter über dem Deck und zu Lande mindestens 4 - 6 Meter hoch angebracht werden. *Lesen Sie den vollständigen Absatz zu: An einer Stelle befestigen [Siting].*
2. Wählen Sie einen Mast mit einem Innendurchmesser von 41.0mm und einem Außendurchmesser von nicht größer als 48.5 mm und mindestens für den Oberen 0.6m, um (i)einen Nebenschaden zu vermeiden und (ii) die Bedingungen der Garantie zu erfüllen.
3. Montieren sie eines der Aufladekontrollgeräte von der Firma Marlec an eine geeignete senkrechte Oberfläche und in der Nähe der Batterie. Befolgen Sie die Anleitung, die mit dem Aufladekontrollgerät mitgeliefert wurde.
4. Bohren Sie, falls erforderlich, in den Montagemast zur Vorbereitung der Befestigung und Inbetriebnahme des Windchargers. *Siehe Montage und Installation [Assembly and Installation].*
5. Wählen sie ein geeignetes zweiadriges Kabel für den Anschluss des Windchargers zum Aufladekontrollgerät. Bis zu 20 Meter, dies sollte mindestens von einer 2.5mm² Querschnittsfläche sein. Ein Kurzabschnitt von einer 4mm² Querschnittsfläche ist für die Verbindung zwischen dem Aufladekontrollgerät und der Batterie erforderlich. *Für weitere Abstände beziehen Sie sich bitte auf die Tabelle Kabelspezifikationen [Cable Specifications].*
6. Bringen Sie den Montagemast in eine bestimmte Stellung, sodass das gewählte Kabel aufgezogen werden kann, das kann auch auf dem Boden durchgeführt werden, bevor sie den Mast anheben.
7. Die Rotorblätter, das Heck- und Vorderteil an den Windcharger mit den mitgelieferten Befestigungsteilen montieren. *Wichtig ist, dass 4 Schrauben pro Rotorblatt angebracht werden.*
8. Schließen Sie das durchgezogene Kabel am Mast mit dem Kabelausgang des Windchargers mit der mitgelieferten Anschlussleiste an und mit Isolierband umwickeln. Es kann als Alternative eine einklinkende Steckvorrichtung verwendet werden. *Wir empfehlen das Kabel zurückzuschlingen, um es mit einem Kabelbinder zu befestigen und eine Zugentlastung am Verbindungsstück zu erzielen.*
9. Die Kabel mit Sorgfalt am Mast hinunter schieben, während das Passstück am Mast herunter geleitet wird. Die Löcher in eine Reihe bringen und an der Stelle mit den mitgelieferten Schrauben und Muttern befestigen und mit dem Sechskantstiftschlüssel befestigen. *Die Turbine darf nicht sich nicht unbehindert im Kreis drehen.*
10. Das Aufladekontrollgerät neben der Batterie lokalisieren und mit Sorgfalt ALLE Richtlinien und Installationsanweisungen für den Anschluss an den Windcharger bis durch zur Batterie befolgen. *Anmerkung: installieren Sie die mitgelieferte In-line Sicherung mit dem Windcharger zwischen der Batterie und dem Aufladekontrollgerät.*
11. Sicherstellen, dass die Batterieanschlüsse dauerhaft sind, da der Windcharger NIE ohne einen Anschluss mit der Batterie in Betrieb genommen werden darf.
12. Den Windcharger anheben und befestigen. Die Drehbewegungen können nun durchgeführt werden. Befolgen sie die im folgenden erläuterte "Inbetriebnahme – 4-Punkte Überprüfliste". *[Up and Running- Four Points Final Checklist]*, ebenso die "Allgemeine Richtlinien und Gefahrenhinweise", die sich auf die obengenannten Punkte beziehen.

For Your Records

For your future reference we recommend you note the following:

Serial Number:

Date of Purchase:

Date of Installation:

Type of Regulator:

Limited Warranty

The Marlec Engineering Company Limited Warranty provides free replacement cover for all defects in parts and workmanship for 24 months from the date of purchase. Marlec's obligation in this respect is limited to replacing parts, which have been promptly reported to the seller and are in the seller's opinion defective and are so found by Marlec upon inspection. A valid proof of purchase will be required if making a warranty claim.

Defective parts must be returned by prepaid post to the manufacturer Marlec Engineering Company Limited, Rutland House, Trevithick Road, Corby, Northamptonshire, NN17 5XY, England, or to an authorised Marlec agent.

This Warranty is void in the event of improper installation, owner neglect, misuse, damage caused by flying debris or natural disasters including lightning and hurricane force winds. This warranty does not extend to support posts, inverters, batteries or ancillary equipment not supplied by the manufacturer.

No responsibility is assumed for incidental damage. No responsibility is assumed for consequential damage. No responsibility is assumed for damage caused by user modification to the product or the use of any unauthorised components.

No responsibility is assumed for use of a non "furling" versions of the Rutland Windcharger where Marlec or one of its authorised agents finds that a generator incorporating a furling device should have been used.

**Manufactured in the UK by
Marlec Engineering Co Ltd
Rutland House,
Trevithick Rd,
Corby, Northants,
NN17 5XY UK**

Tel: +44 (0)1536 201588 Fax: +44 (0)1536 400211

Email: sales@marlec.co.uk

www.marlec.co.uk

Did you know...

Marlec also offer
**Solar Energy
Systems!**



Solar power that works with your
Rutland Windcharger

Solar power to keep batteries
topped up on-board



Energy saving solar panels
for your home



Marlec Engineering Co Ltd
Rutland House, Trevithick Road, Corby, NN17 5XY
Tel:+44 (0)1536 201588 Fax:+44 (0)1536 400211
sales@marlec.co.uk
www.marlec.co.uk