

Edelstahl- Einbaugriffe EE

Edelstahlklappgriffe mit geringer Einbautiefe, für Boden- und Montageplatten, Geräte und Klapptüren.

Werkstoff und Oberfläche:
Edelstahl hochglanz-elektro-
poliert, Werkstoff-Nr. 1.4301;
Ausführung EE-03 zusätzlich in
gebürsteter Ausführung.

Konstruktive Merkmale:
Mit Griff-Rückstellfeder von der
Arbeits- in die Ruhestellung.
Ausführung EE-04 mit dreh-
und abschließbarem Vorreiber
für Klapptüren.

Tragkraft:
min. 200 N.



Typ EE-01

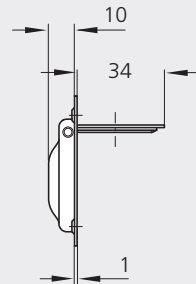
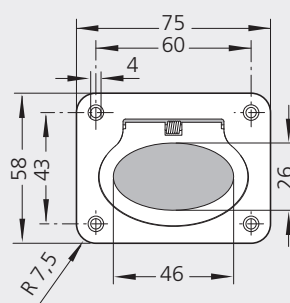

Montageöffnung
Mounting cutout

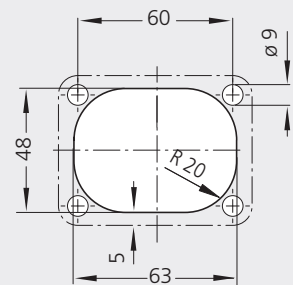

Bestell-Nr. / Order no.

EE-01.R075.39

Typ EE-02

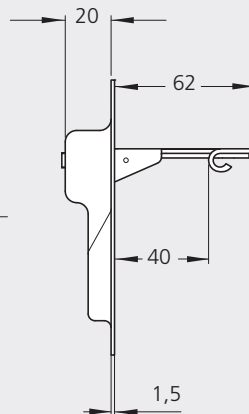
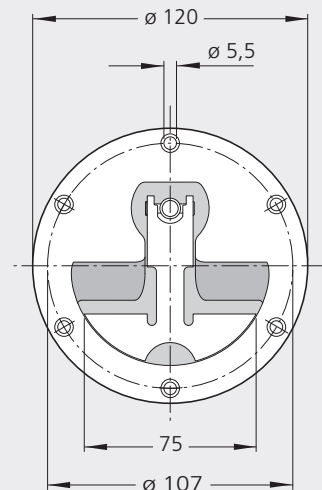

Montageöffnung
Mounting cutout

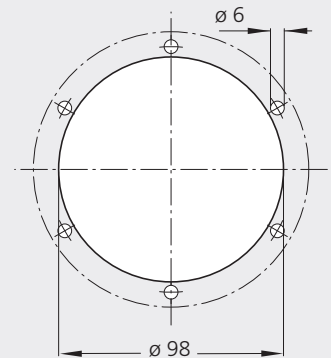

Bestell-Nr. / Order no.

EE-02.R120.39



Stainless Steel Installation Handle EE

Collapsible stainless steel handles with small installation depth, for devices and clapping doors.

Material and surface:

Stainless steel high gloss electropolished, material no. 1.4301; version EE-03 additionally in brushed design.

Design features:

With pull-back spring from the working to the resting position. Version EE-04 with turn- and lockable latch for clapping doors.

Stress resistance:

min. 200 N.

Typ EE-03

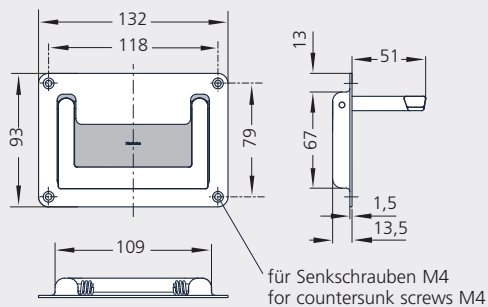

Montageöffnung Mounting cutout

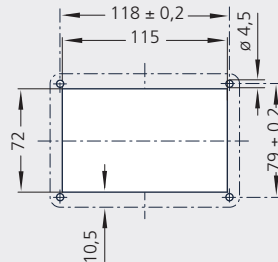

Ausführung Version

Bestell-Nr.
Order no.

gebürstet / brushed

EE-03.118.33

elektropoliert / electropolished

EE-03.118.39

Typ EE-04

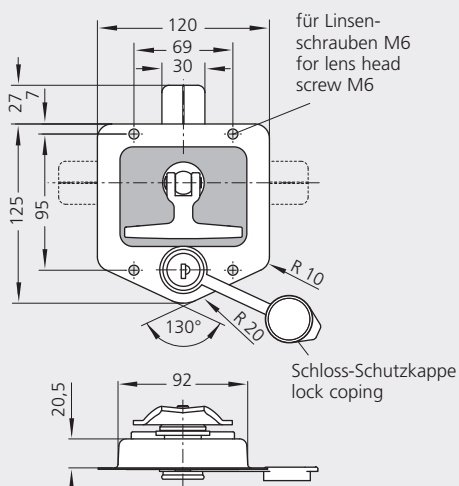

Montageöffnung Mounting cutout

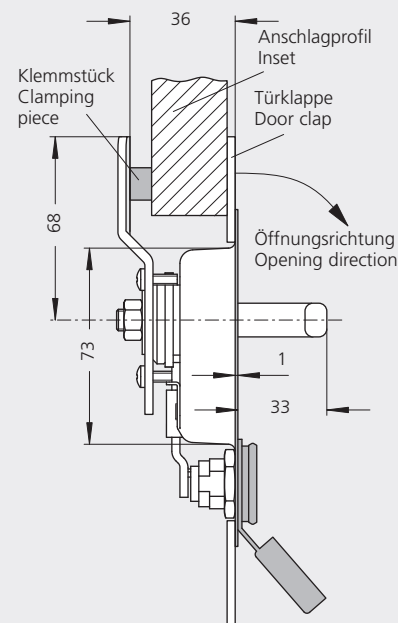
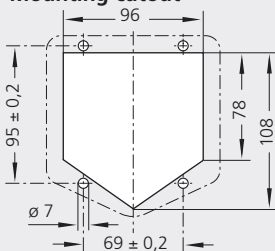

Hinweis:

Je nach der Gesamtstärke der Türklappe und des Anschlagprofils, ist ein kundenseitig hergestelltes Klemm-Zwischenstück erforderlich.

Note:

Regarding on the thickness of the door-clap and the inset a clamping adaptor manufactured by the customer is necessary.

Bestell-Nr. / Order no

EE-04.069.39



Typ EE-03
gebürstet / brushed

Weitere Klappgriffe
s. S. 184–186.
Other collapsible handles
see page 184–186.

