



Getting started with
Logitech® Stereo Headset H151



English	3
Deutsch	7
Français	11
Italiano	15

 What's in the box

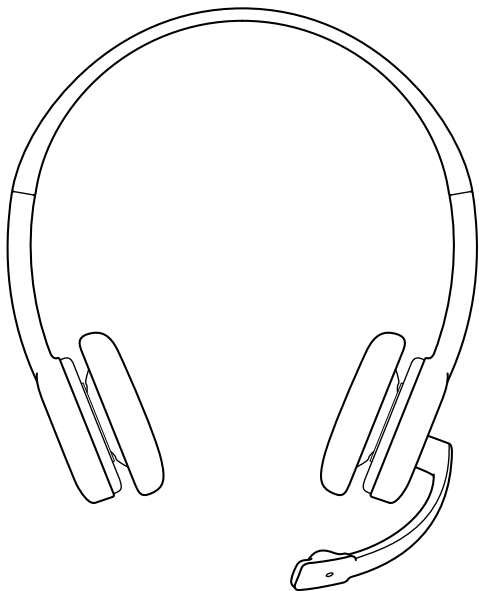

Headset features

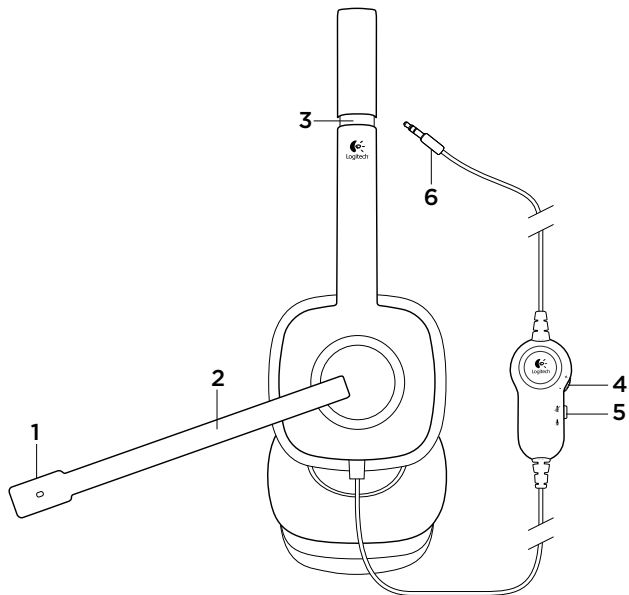

1. Noise-canceling microphone
2. Rotating microphone boom
3. Adjustable headband

4. Volume control
5. Mute switch
6. Single Headphone and Microphone plug

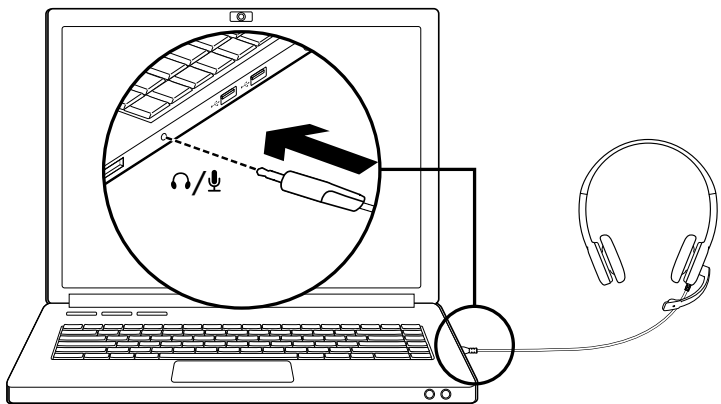
 Setup

Connect the headset

Insert the 3.5 mm plug into the single headphone & microphone jack on your computer, tablet or smartphone.

Help with setup: headset not working?

- Check cable connection between the headset and your computer.
- If your computer is using two separate jacks for microphone and headphone, a 1-to-2 adapter is necessary to use all the features of this headset.
- Adjust the volume and microphone settings to an audible level in the application and operating system.
- Try restarting the media application.
- Close all media applications and check whether your computer soundcard has been selected in your Windows operating system for playback and voice.

Windows Vista and Windows 7: Go to Start/Control Panel/Sounds/Playback Devices tab. Choose your sound card and click OK. Go to the Recording devices tab, choose your sound card, and click OK. Restart the media application.

Windows 8: From Start Menu, select Desktop tile. From Charms menu, select Settings > Control Panel > Hardware and Sound. Go to Sound > Playback tab. Choose your sound card and click OK. Go to the Recording devices tab, choose your sound card, and click OK. Restart the media application.

For additional assistance, please visit www.logitech.com/support.

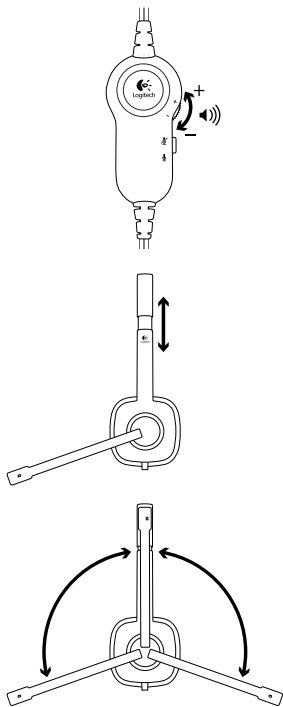

 Inhalt

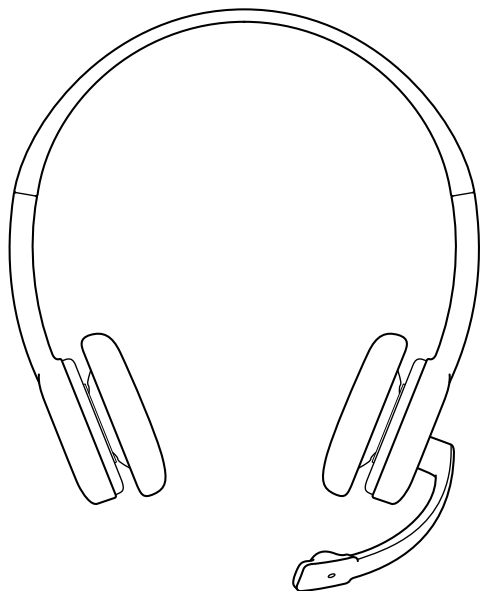

Headset-Funktionen

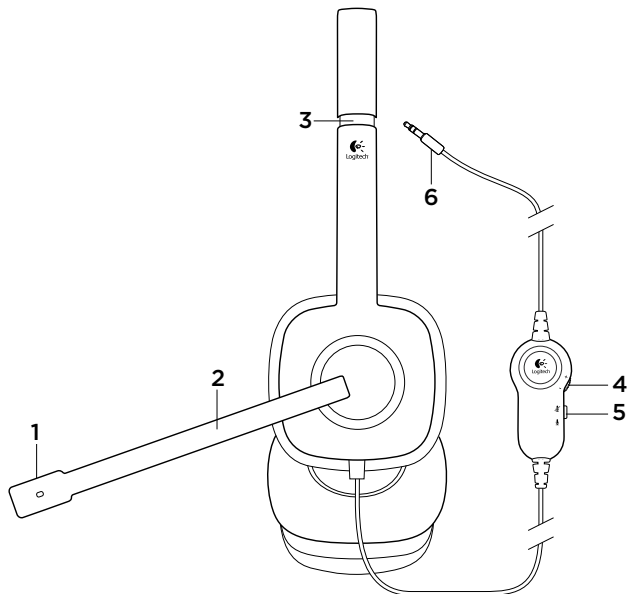

1. Mikrophon mit Rauschunterdrückung
2. Drehbarer Mikrophonbügel
3. Verstellbarer Kopfbügel

4. Lautstärkeregelung
5. Stummschalter
6. Ein Stecker für Kopfhörer und Mikrophon

✖ Einrichtung

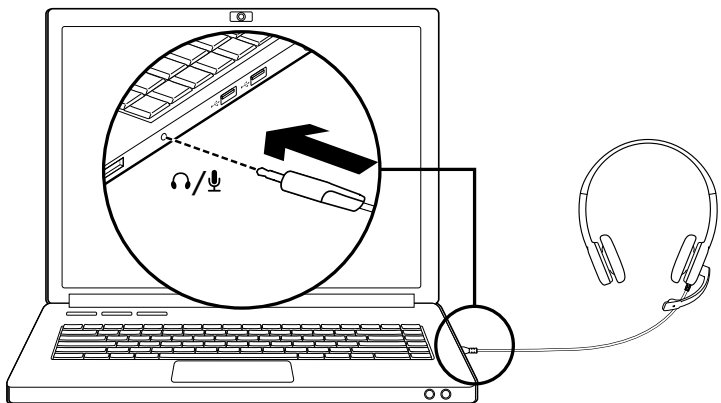

Headset anschließen

Stecken Sie den 3,5-mm-Stecker in die Kopfhörer- und Mikrofonbuchse Ihres Computers, Tablets oder Smartphones.

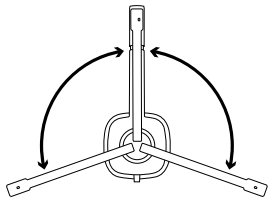
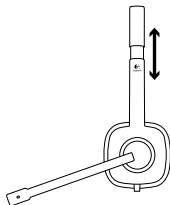
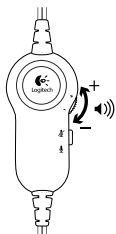

Probleme bei der Einrichtung: Headset funktioniert nicht

- Überprüfen Sie die Kabelverbindung zwischen dem Headset und dem Computer.
- Wenn Ihr Computer über zwei verschiedene Buchsen für Mikrofon und Headset verfügt, ist ein Y-Adapter erforderlich, um alle Funktionen dieses Headsets nutzen zu können.
- Stellen Sie die Lautstärke- und Mikrofon-Einstellungen des Betriebssystems und der Anwendung auf einen hörbaren Pegel ein.
- Starten Sie die Multimedia-Anwendung neu.
- Schließen Sie alle Multimedia-Anwendungen und überprüfen Sie, ob die Soundkarte Ihres Computers im Windows-Betriebssystem für Wiedergabe und Stimme ausgewählt ist.

Windows Vista und Windows 7: Klicken Sie auf „Start > Systemsteuerung > Sounds“ und wählen Sie die Registerkarte „Wiedergabegeräte“. Wählen Sie Ihre Soundkarte und klicken Sie auf „OK“. Klicken Sie auf die Registerkarte „Aufnahmegereäte“, wählen Sie Ihre Soundkarte und klicken Sie auf „OK“. Starten Sie die Multimedia-Anwendung neu.

Windows 8: Wählen Sie aus dem Startmenü die Desktop-Kachel. Wählen Sie im Charms-Menü „Einstellungen > Systemsteuerung > Hardware und Sound“. Klicken Sie auf „Sound“ und wählen Sie die Registerkarte „Wiedergabe“. Wählen Sie Ihre Soundkarte und klicken Sie auf „OK“. Klicken Sie auf die Registerkarte „Aufnahmegereäte“, wählen Sie Ihre Soundkarte und klicken Sie auf „OK“. Starten Sie die Multimedia-Anwendung neu.

Weitere Informationen finden Sie unter www.logitech.com/support.

 Contenu du coffret

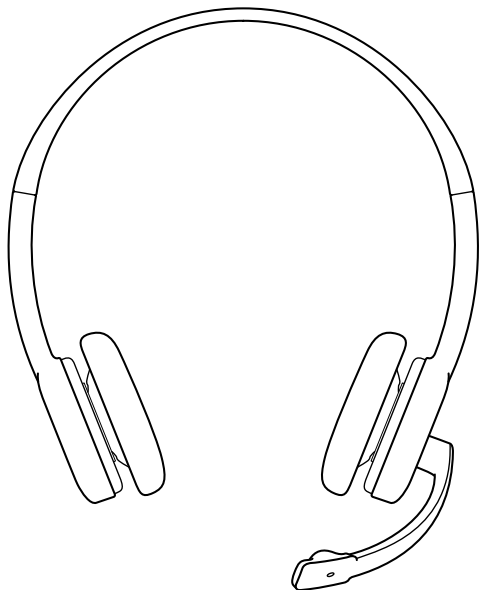

Fonctionnalités du casque avec micro

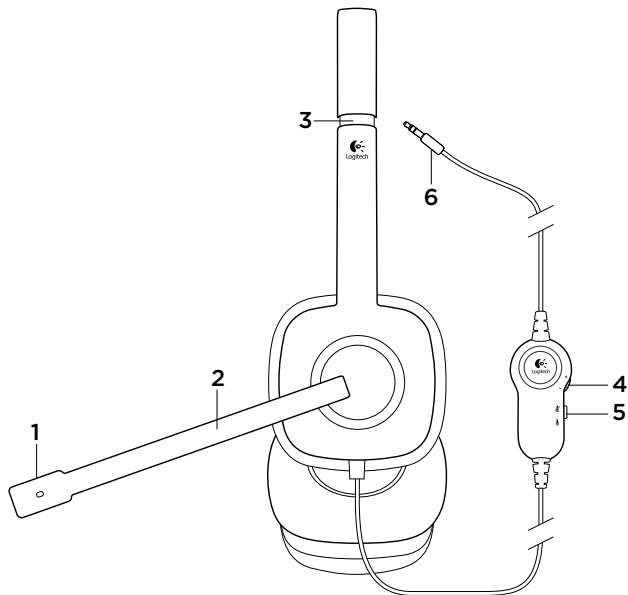

1. Micro anti-parasites
2. Tige de micro rotative
3. Bandeau réglable

4. Contrôle du volume
5. Commutateur de sourdine
6. Prise casque et micro unique

✖ Installation

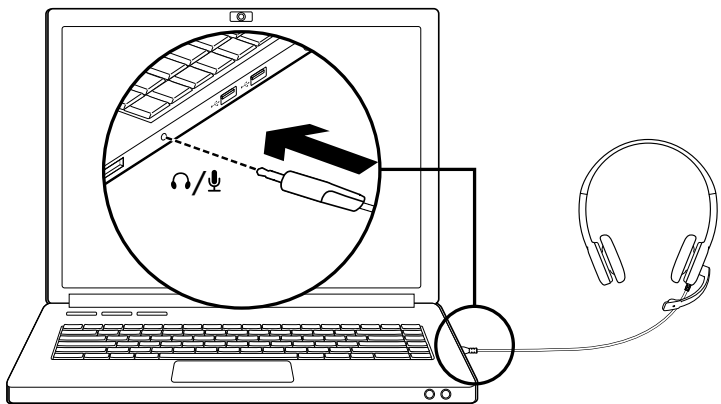

Connexion du casque

Branchez la prise 3,5 mm sur le port casque et micro unique de votre ordinateur, tablette ou smartphone.

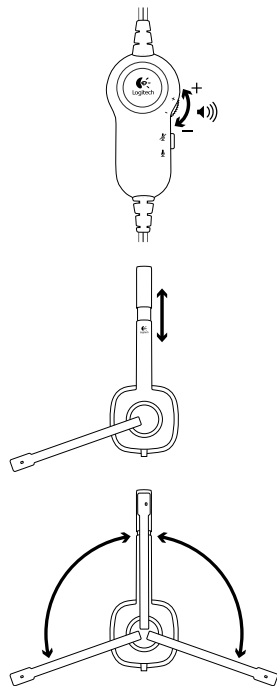

Aide à la configuration: le casque ne fonctionne pas?

- Vérifiez la connexion du câble entre le casque avec micro et votre ordinateur.
- Si votre ordinateur utilise deux ports séparés pour le microphone et le casque, un adaptateur 1 à 2 est nécessaire pour utiliser toutes les fonctionnalités de ce casque avec micro
- Réglez les paramètres de volume et du micro à un niveau audible dans le système d'exploitation et dans l'application.
- Essayez de redémarrer l'application multimédia.
- Fermez toutes les applications multimédia et vérifiez si la carte son de votre ordinateur est bien sélectionnée dans les paramètres Lecture audio et Voix de votre système d'exploitation Windows.

Windows Vista et Windows 7: Sélectionnez Démarrer/ Panneau de configuration/Sons/onglet Périphériques de lecture. Sélectionnez votre carte son et cliquez sur OK. Cliquez sur l'onglet Périphériques d'enregistrement et sélectionnez votre carte son, puis cliquez sur OK. Redémarrez l'application multimédia.

Windows 8: Dans le menu Démarrer, sélectionnez la vignette Bureau. Dans le menu Icônes, sélectionnez Paramètres > Panneau de configuration > Matériel et audio. Accédez à Sons > onglet Lecture. Sélectionnez votre carte son et cliquez sur OK. Cliquez sur l'onglet Périphériques d'enregistrement et sélectionnez votre carte son, puis cliquez sur OK. Redémarrez l'application multimédia.

Pour toute aide supplémentaire,
visitez le site www.logitech.com/support.

 Contenuto della confezione

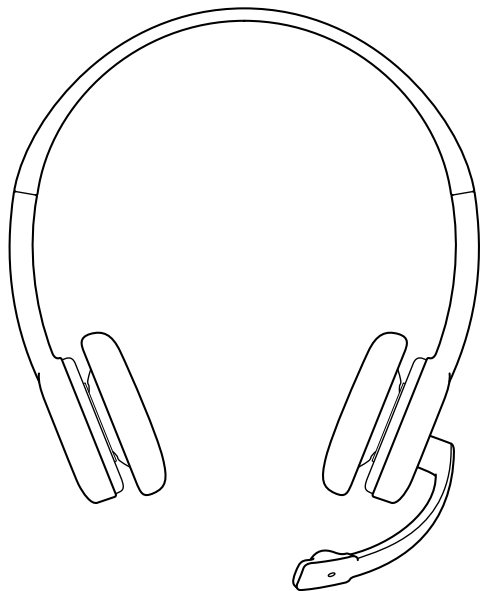

Caratteristiche delle cuffie con microfono

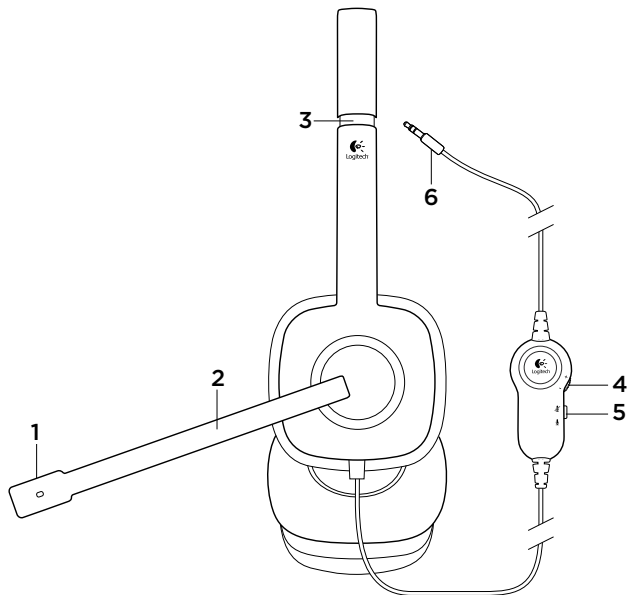

1. Microfono con eliminazione del rumore
2. Braccio del microfono girevole
3. Fascia per la testa regolabile

4. Regolazione del volume
5. Pulsante per la disattivazione dell'audio
6. Spinotto unico per microfono e cuffie

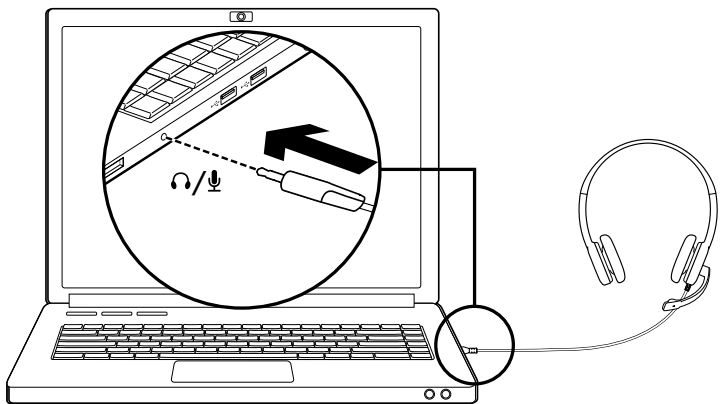
Installazione di **Collegamento delle cuffie con microfono**

Inserire lo spinotto da 3,5 mm nell'ingresso singolo per cuffie e microfono del computer, tablet o smartphone.

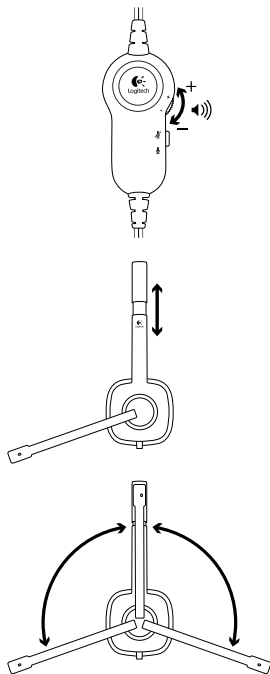

Problemi di configurazione: le cuffie non funzionano?

- Controllare che il cavo delle cuffie sia collegato correttamente al computer.
- Se il computer dispone di due ingressi separati per microfono e cuffie, per utilizzare tutte le funzionalità di questa cuffia con microfono è necessario un adattatore da 1 a 2.
- Nel sistema operativo e nell'applicazione, regolare le impostazioni del volume e del microfono su un livello udibile.
- Provare a riavviare l'applicazione multimediale.
- Chiudere tutte le applicazioni multimediali e controllare che la scheda audio del computer sia stata selezionata per riproduzione e voce nel sistema operativo Windows.

Windows Vista e Windows 7: Scegliere Start/Pannello di controllo/Suoni/scheda Dispositivi di riproduzione. Selezionare la scheda audio utilizzata e fare clic su OK. Fare clic sulla scheda Dispositivi di registrazione, selezionare la scheda audio utilizzata e fare clic su OK. Riavviare l'applicazione multimediale.

Windows 8: Nel menu Start, selezionare il riquadro Desktop. Dal menu Accessi, selezionare Impostazioni > Pannello di controllo > Hardware e suoni. Scegliere Audio > scheda Riproduzione. Selezionare la scheda audio utilizzata e fare clic su OK. Fare clic sulla scheda Dispositivi di registrazione, selezionare la scheda audio utilizzata e fare clic su OK. Riavviare l'applicazione multimediale.

Per ulteriore assistenza,
visitare la pagina www.logitech.com/support.



www.logitech.com/support/H151

© 2015 Logitech. All rights reserved. Logitech, the Logitech logo, and other Logitech marks are owned by Logitech and may be registered. All other trademarks are the property of their respective owners. Logitech assumes no responsibility for any errors that may appear in this manual. Information contained herein is subject to change without notice.

621-000490.002