

Art.Nr.: 71000311 - Pendelfederaufhängung

Kompatibel mit allen gängigen Nutzfahrzeug-Modellbausätzen in den Maßstäben 1:13 - 1:16

- geeignet für ScaleDRIVE, Tamiya® und Wedico® Fahrgestelle
- glasfaserverstärkte Kunststofffederböcke
- alle Schrauben aus rostfreiem Stahl
- Federblätter aus Titanbronze
- für normale Fahrgestellhöhe und höher gelegte Off Road Fahrzeuge
- ein hohes Maß an variablen Montagemöglichkeiten



www.SCALEDRIVE.de



ScaleART OHG - Schillerstraße 3-7 - D 67165 Waldsee

Tel.: +49 (0) 6236-416651 - Mail: info@scaleart.de

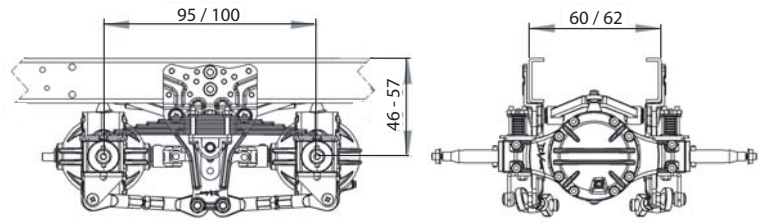

A	Teilesatz Pendelfederung	2	15000210
B	Teilesatz Federblätter	2	15000072
01	Dreieckslenker	2	15000205
02	Achshalter unten links	2	15000219
03	Achshalter unten rechts	2	15000220
04	Teilesatz Federauflage	1	15000224
05	Halter Dreieckslenker TAM	2	15000222
06	Buchse Drehlager	6	15000029
07	Kugelgelenk M3	8	32900414
08	Kugelgelenk M2	2	32900405
09	Schraube M2x6	18	32000012
10	Schraube M2x12	8	32000015
11	Schraube M2x14	10	32000016
12	Schraube M3x6	3	32000052
13	Schraube M3x12	5	32000055
14	Schraube M3x14	5	32000056
15	Schraube M3x16	5	32000057
16	Schraube M3x20	5	32000059
17	Inbuschraube M3x20	10	32000595
18	Gewindestift M3x16	8	32000247
19	Mutter M2	35	32000002
20	Mutter M3	20	32000004
21	Mutter selbstsichernd M3	12	32000913
22	Scheibe D2	3	32000180
23	Scheibe D3,2	10	32000222

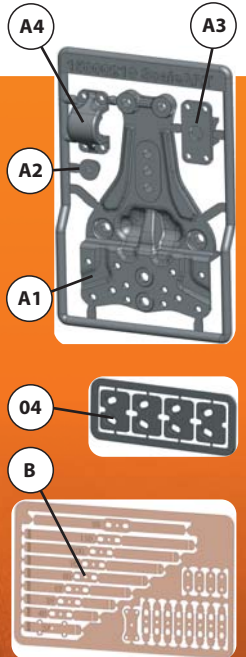

Dieses Modell ist kein Spielzeug und für Jugendliche unter 14 Jahren nicht geeignet. Jegliche technische Änderung und Modifikation behalten wir uns vor. Für Irrtümer und Druckfehler übernehmen wir keine Haftung. Nachdruck und Vervielfältigung sind nur mit unserer ausdrücklichen, schriftlichen Genehmigung gestattet.

Tamiya ist eine eingetragene Marke der DICKIE-TAMIYA Modellbau GmbH & Co. KG
Wedico ist eine eingetragene Marke der WEDICO Truck & Construction Models GmbH

Hinweis zur Montage!

Das Pendelfedersystem lässt sich in zwei Maßstabklassen montieren.

Maßstab 1:14 für Modelle im Tamiya® Maßstab 1:14

In dieser Maßstabklasse haben die Modelle eine Rahmenbreite von 62mm und einen Achsabstand der Hinterachsen von ca. 100mm.

Maßstab 1:16 für Modelle im ScaleART und Wedico® Maßstab 1:14,5 - 1:16

In dieser Maßstabklasse haben die Modelle eine Rahmenbreite von 60mm und einen Achsabstand der Hinterachsen von ca. 95mm.

Zusätzlich lässt sich die Pendelfederung in verschiedenen Höhen montieren. Die oberste Bohrung im Federträger entspricht einer normalen Rahmenhöhe für Straßenfahrzeuge und ist auch nahezu identisch mit der Rahmenhöhe der Tamiya® und Wedico® Bausätze.

Die mittlere Bohrung entspricht einer Rahmenerhöhung von 5,5mm und die unterste von 11mm.



Straßenniveau
5,5mm Höherlegung
11mm Höherlegung

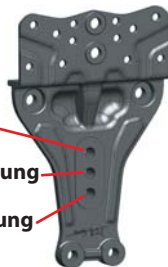

Zur Montage wird das folgende Werkzeug benötigt:

Kreuzschlitzschraubendreher	Art.Nr.: 96000007
Steckschlüssel 4,0mm	Art.Nr.: 96000016
Steckschlüssel 5,5mm	Art.Nr.: 96000018
Innensechskantschlüssel 1,5mm	Art.Nr.: 96000009
Innensechskantschlüssel 2mm	Art.Nr.: 96000010
Spitzzange	Art.Nr.: 96000051
Seitenschneider	Art.Nr.: 96000052
Skalpell	Art.Nr.: 96000036
Schraubensicherung mittelfest	Art.Nr.: 60000504
kleine Feile	

In der Abfolge der Bauanleitung sind die einzelnen Montageschritte mit "1:14" und "1:16" gekennzeichnet, damit Sie einfach erkennen können, welche Montagevariation zu Ihrem Modell passt.

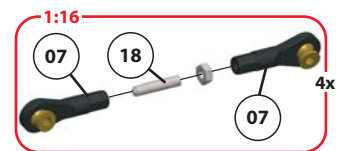
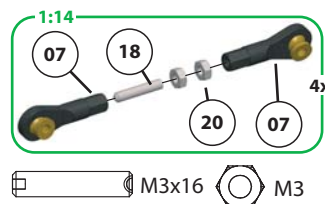

M3x16 M3

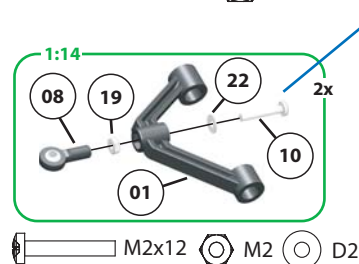

Schraubensicherung

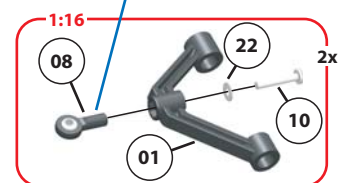

M2x12 M2 D2

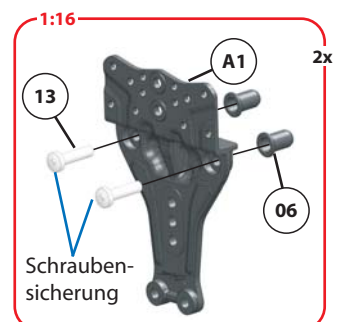
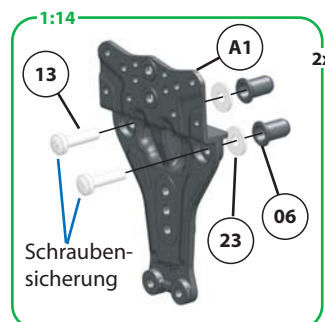

M3x12 D3,2

SCALEDRIVE

POWERED BY SCALEART

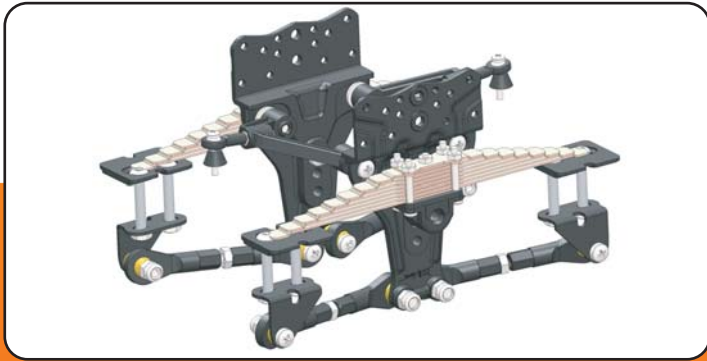

Item nr.: 7100311 - pendulary spring suspension

Compatible with all common commercial vehicle construction-kits in scales 1:13 - 1:16

- suitable for ScaleDRIVE, Tamiya® und Wedico® chassis
- fibre-glass reinforced plastic spring brackets
- all screws are made of stainless steel
- the leaf springs are made of titanium bronze
- suitable for normal chassis heights and for raised off-road vehicles
- there are multiple options for mounting the springs



www.SCALEDRIVE.de



ScaleART OHG - Schillerstraße 3-7 - D 67165 Waldsee

Tel.: +49 (0) 6236-416651 - Mail: info@scaleart.de

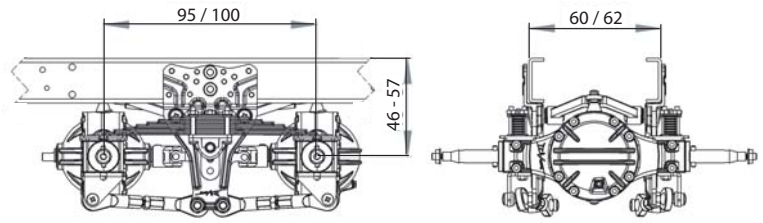

A	set of parts for pendulary spring	2	15000210
B	set of leaf springs	2	15000072
01	three angular steering lever	2	15000205
02	left bottom axle bracket	2	15000219
03	right bottom axle bracket	2	15000220
04	set of sliding plates	1	15000224
05	TAM bracket for steering lever	2	15000222
06	bushing for spring support	6	15000029
07	ball rod end M3	8	32900414
08	ball rod end M2	2	32900405
09	screw M2x6	18	32000012
10	screw M2x12	8	32000015
11	screw M2x14	10	32000016
12	screw M3x6	3	32000052
13	screw M3x12	5	32000055
14	screw M3x14	5	32000056
15	screw M3x16	5	32000057
16	screw M3x20	5	32000059
17	Allen screw M3x20	10	32000595
18	worm screw M3x16	8	32000247
19	nut M2	35	32000002
20	nut M3	20	32000004
21	self-locking nut M3	12	32000913
22	washer d2	3	32000180
23	washer d3,2	10	32000222

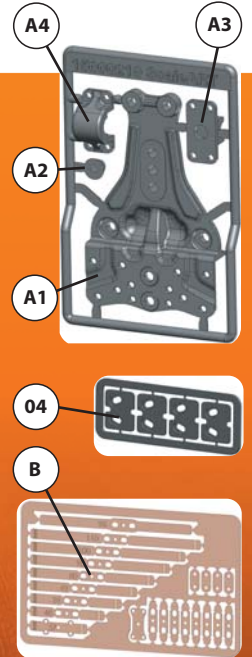

This model is not a toy. Furthermore it is not qualified for the use of children under the age of 14. Technical changes and modifications are reserved. We do not take any responsibility for misprints or misunderstanding of the construction detail. Reproducing and multiplying our construction plans without our permission will be prosecuted.

Tamiya is a trademark from DICKIE-TAMIYA Modellbau GmbH & Co. KG
Wedico is a trademark from WEDICO Truck & Construction Models GmbH

Notice for assembling!

The pendulary spring suspension can be mounted in two different types of scales.

Scale 1:14 for models in Tamiya® scale 1:14:

According to this type of scale the chassis has a width of 62mm and a center distance of the rear-axles of about 100mm.

Scale 1:16 for models in ScaleART and Wedico® scale 1:14,5 - 1:16:

Those scales have a chassis width of 60mm and a center distance of the rear-axles of about 95mm.

Additionally the pendulary spring suspension can be mounted in different heights.

The upper drill of the spring support suits for normal chassis-heights for road vehicles and is almost identically with the chassis-height of the Tamiya® and the Wedico® construction-kits.

The hole in the middle is equivalent to a chassis-height increase of 5.5 mm and for the the bottom hole its 11mm increased height.



street level
5,5mm increase height
11mm increased height



The following tools are required for assembly:

- Phillips screwdriver
- socket wrench 4,0mm
- socket wrench 5,5mm
- Allen key 1,5mm
- Allen key 2mm
- nose plier
- diagonal cutter
- scalpell
- tread locking fluid medium str.
- small file

- Art.Nr.: 96000007
- Art.Nr.: 96000016
- Art.Nr.: 96000018
- Art.Nr.: 96000009
- Art.Nr.: 96000010
- Art.Nr.: 96000051
- Art.Nr.: 96000052
- Art.Nr.: 96000036
- Art.Nr.: 60000504

In the sequence of the instructions the individual mounting steps are highlighted as "1:14" and "1:16" so you will immediately see which instructions you will need for your model.

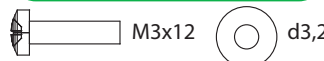
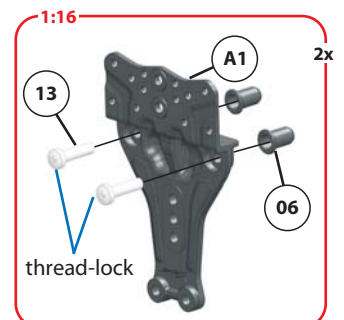
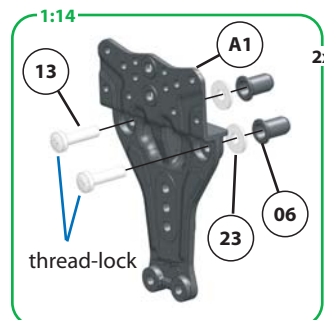
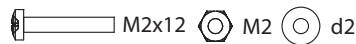
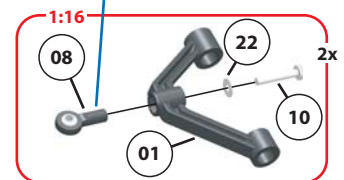
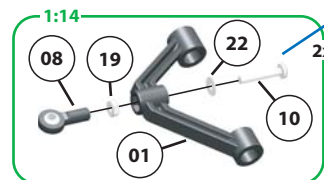
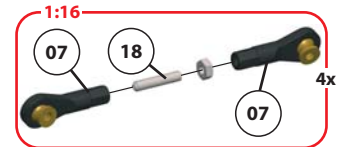
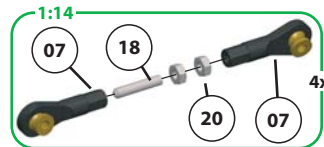

Montage an ein Tamiya® Differential

Montage an ein ScaleDRIVE Differential

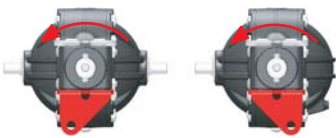
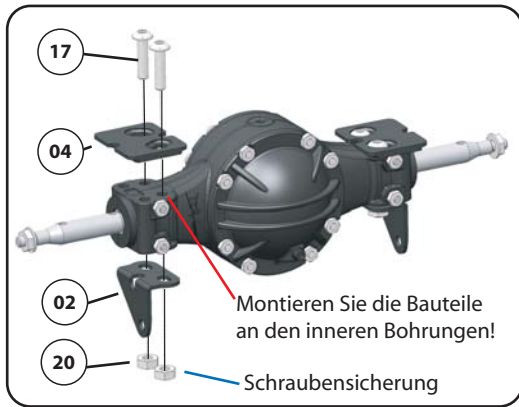

Achten Sie bei der Montage der Achsen auf den richtigen Drehsinn der Achse, so dass alle Räder in die gleiche Richtung drehen!

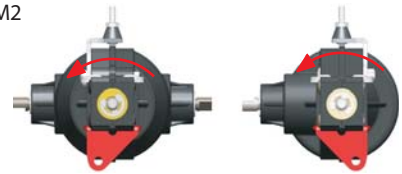
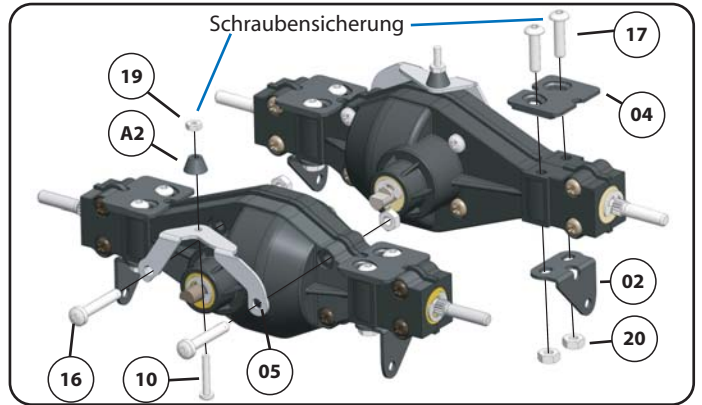

Montage an ein ScaleDRIVE Fahrgestell

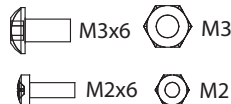
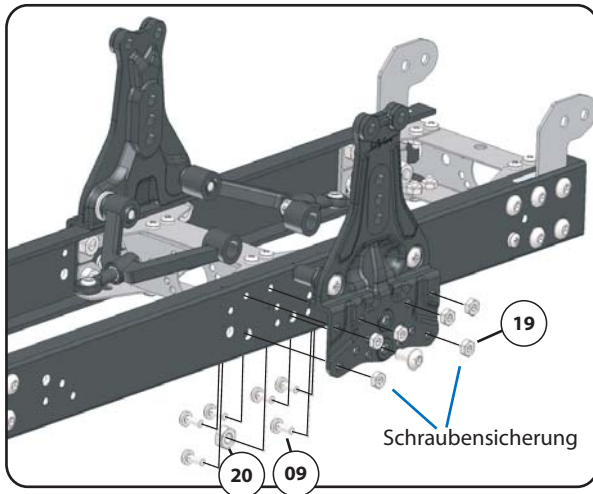

Montage an ein Wedico® Profi Fahrgestell

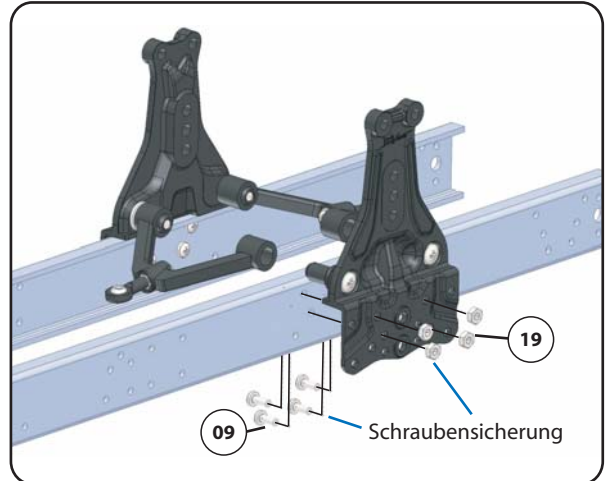

Achten Sie bei der Montage der Seitenplatten am Rahmen darauf, dass die Anschlagfläche parallel zum Rahmen steht!

Für Fahrzeuge mit Straßenniveau und 5,5mm Höherlegung werden die Dreieckslenker in dieser Ausrichtung eingebaut:

Für Fahrzeuge mit 11mm Höherlegung werden die Dreieckslenker in dieser Ausrichtung eingebaut:

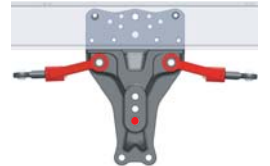
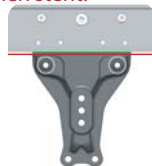

Montage an ein Tamiya® Fahrgestell

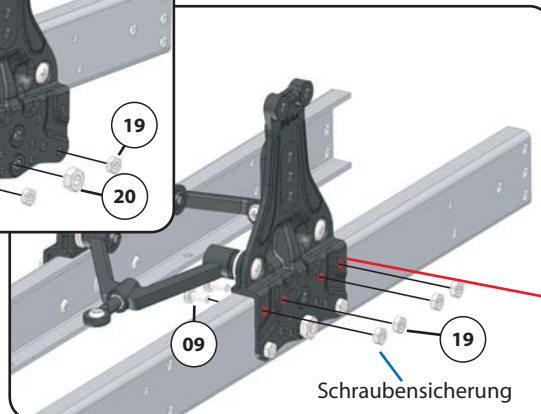
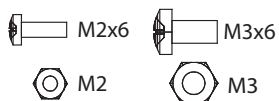
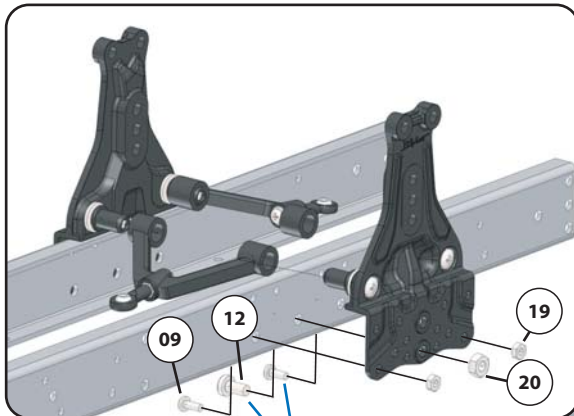

Bei dem Tamiya® Fahrgestell wird die Rahmentraverse im Bereich der Pendelfederaufhängung nicht eingebaut.

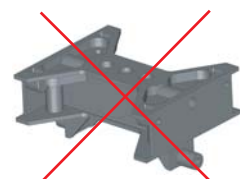

Montieren Sie zuerst die seitlichen Trägerplatten mit 3 Schrauben am Rahmen. Bohren Sie dann die unteren 4 Löcher mit einem 2mm Bohrer durch und setzen Sie die restlichen Schrauben ein.

Assembling to a Tamiya® differential

Assembling to a ScaleDRIVE differential

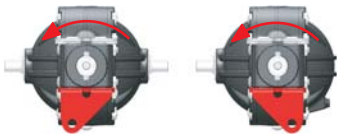
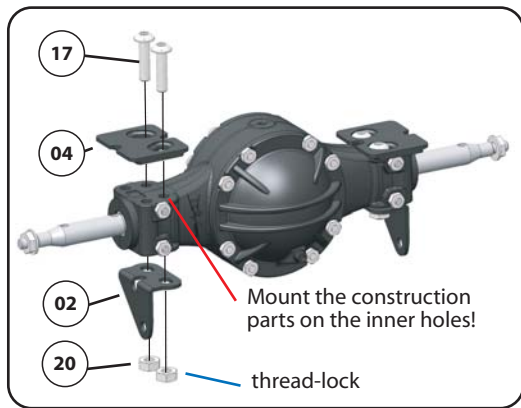

When mounting the axles be aware of the direction of rotation. Otherwise the wheels will turn in different directions!!

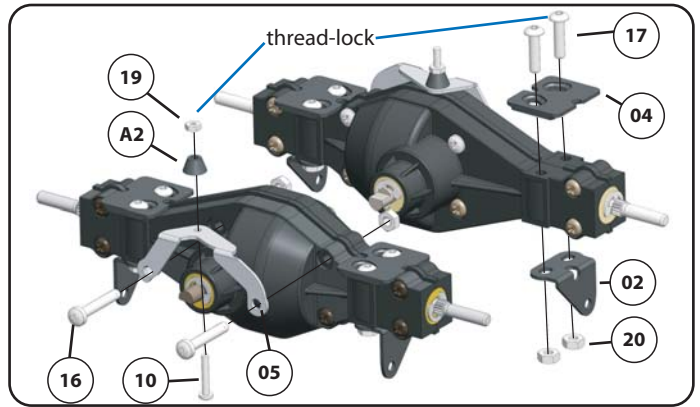

Assembling to a ScaleDRIVE chassis

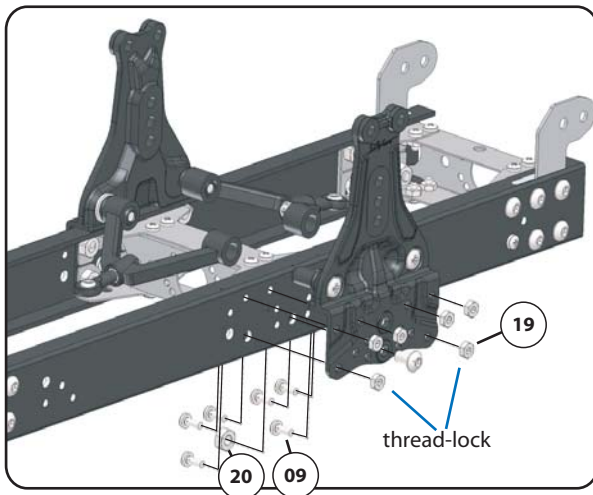

Assembling to a Wedico® profi chassis

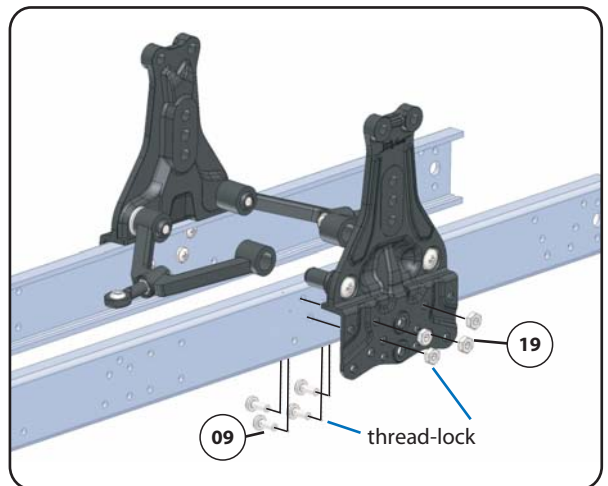

Make sure when mounting the side panels on the frame that the stop surface is parallel to the frame!

For vehicles with street level and 5.5mm increased height the three angular steerings are mounted in this orientation:

For vehicles with 11mm increased height the three angular steerings are mounted in this orientation:



Assembling to a Tamiya® chassis

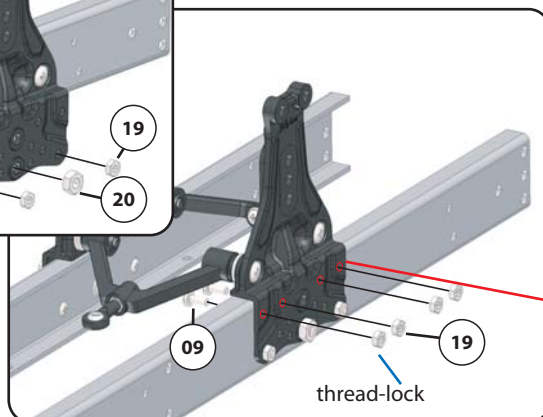
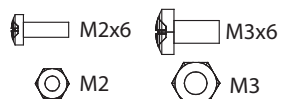
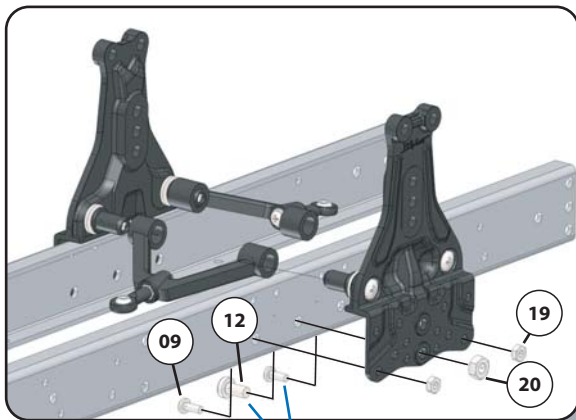

For the Tamiya® chassis the crossmember is not mounted in the area of the pendular spring suspension.

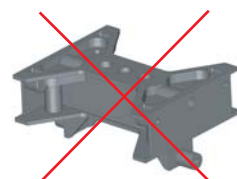

First mount the side support plates with three screws on the frame. Then drill the lower 4 holes with a 2 mm drill and insert the remaining screws.

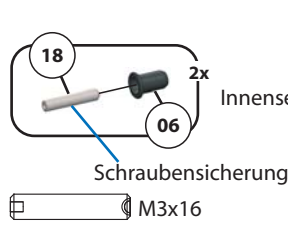

Montieren Sie den Gewindestift mit Schraubensicherungsmittel so in der Buchse, dass der Sechskant innen in der Buchse sitzt.

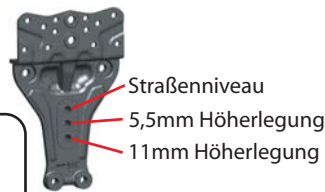
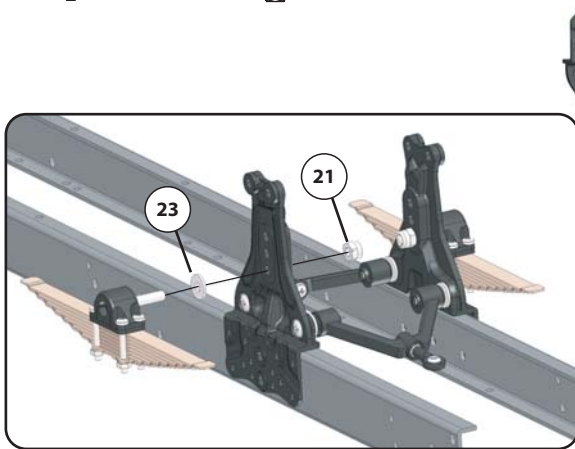
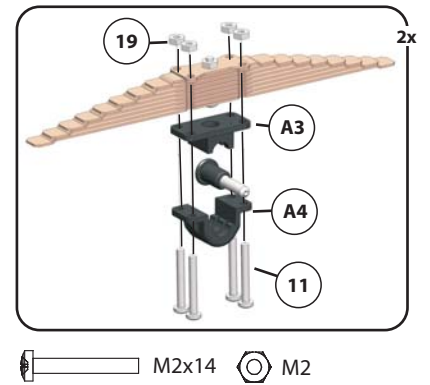
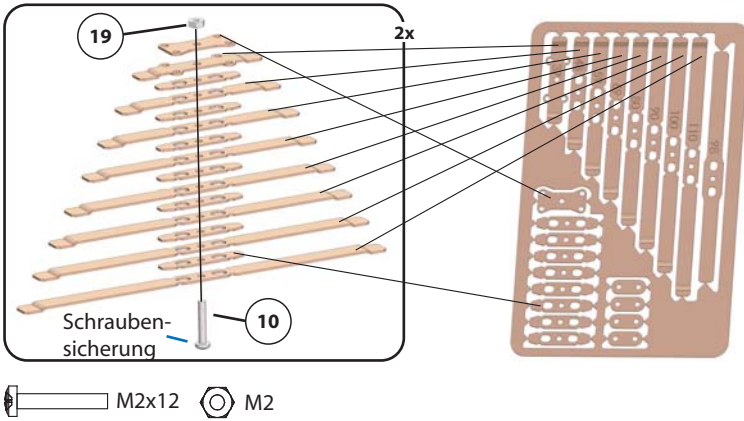

Montieren Sie das Federpaket entsprechend der von Ihnen gewünschten Fahrstellhöhe in der richtigen Bohrung!

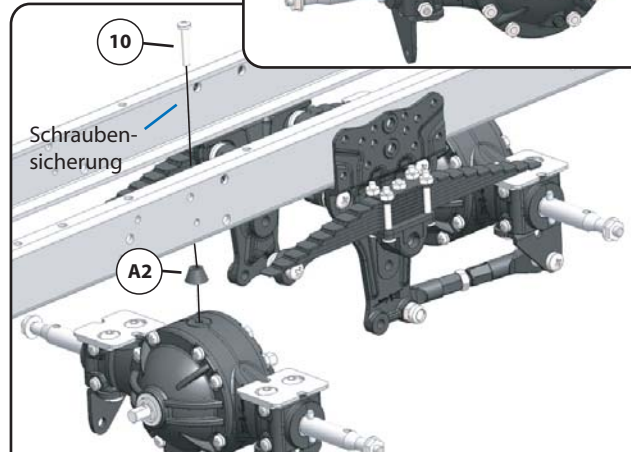
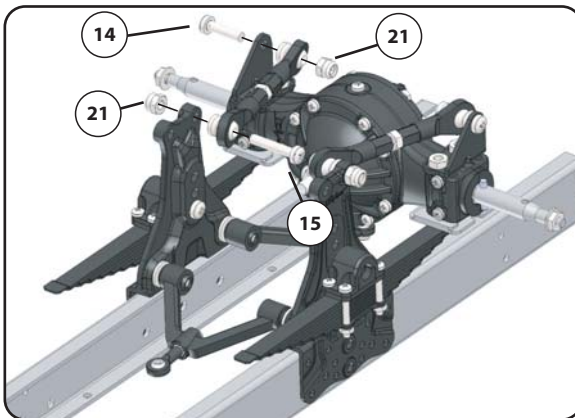
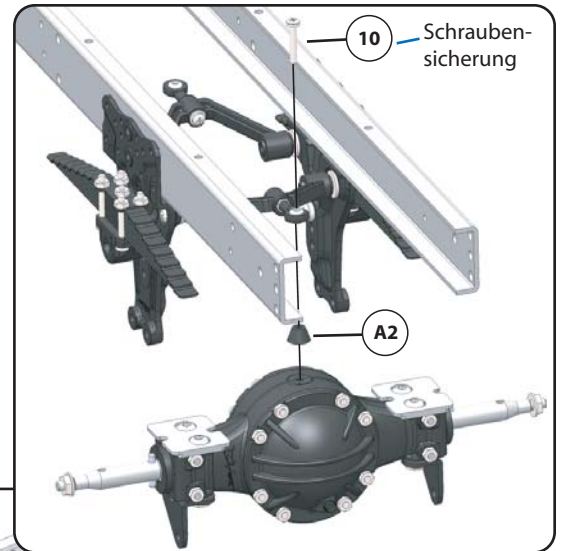

Montieren Sie die Kardanwelle bevor alle Kugelköpfe angeschraubt haben!

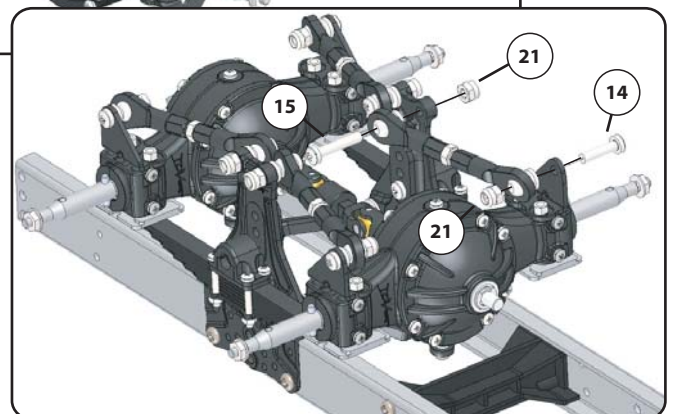
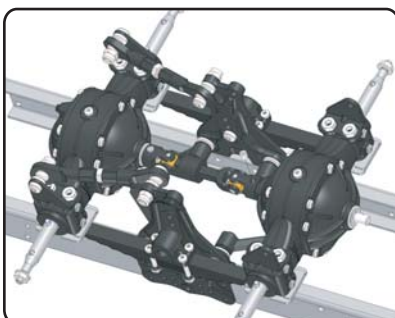

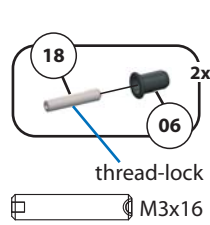

12
hexagon
Mount the worm screw with thread-lock in the bushing so that the hexagon sits inside.

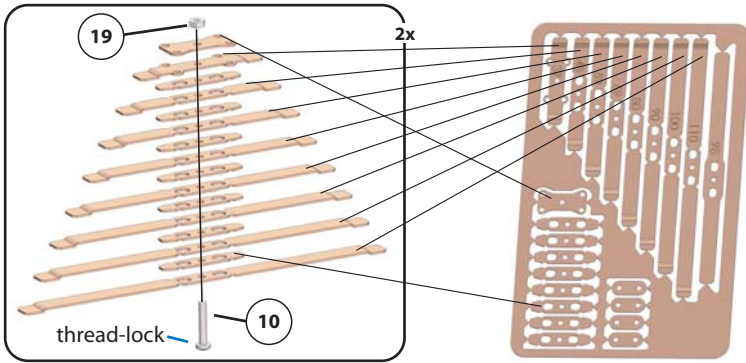

M2x12 M2

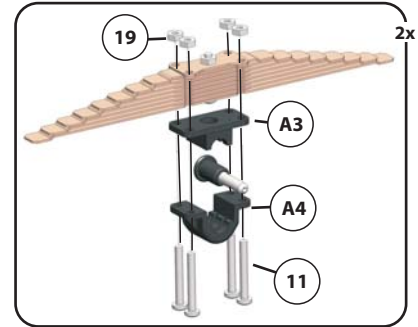

M2x14 M2

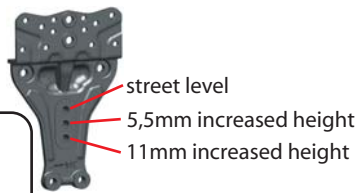
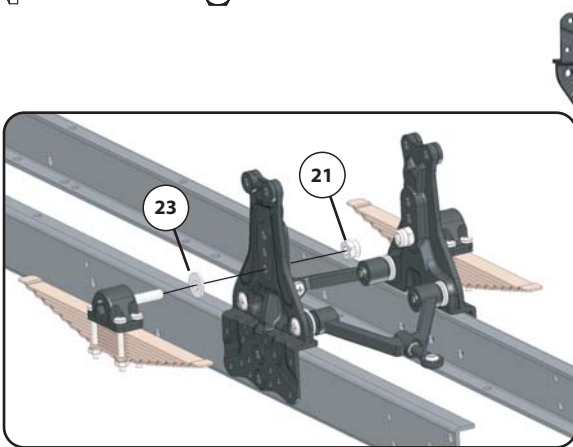

Mount the spring assembly in accordance with the chassis height of your choice. Make sure you use the suiting drills for your chassis-height!!

M3 self-locking M3x14 M3x16 M2x12

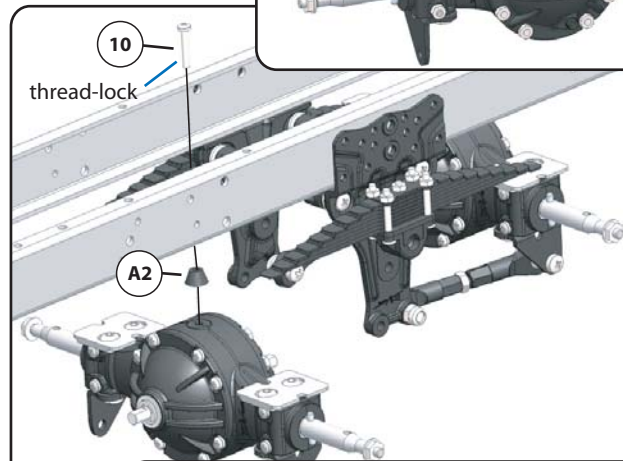
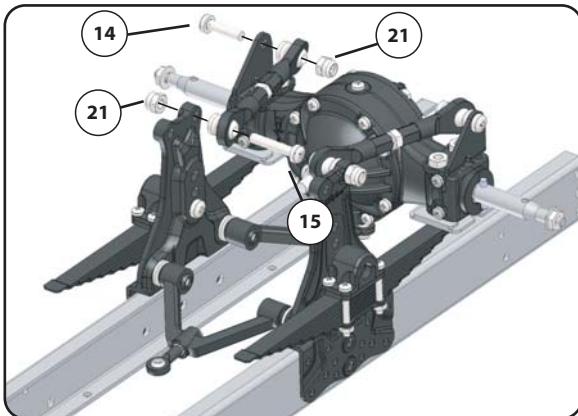
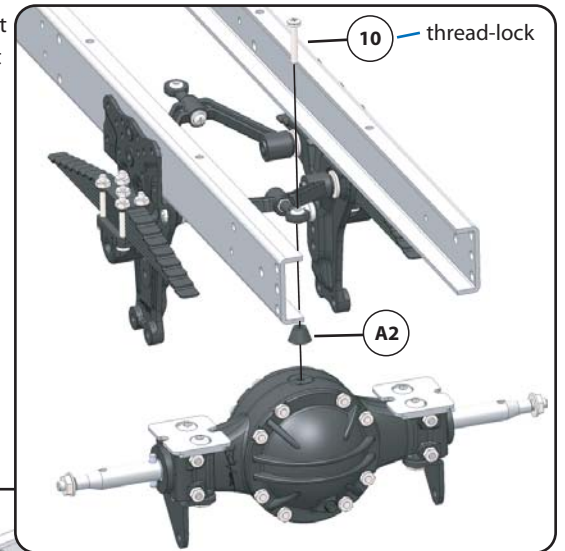

Assemble the driving-shaft before you have fixed all ball rod ends.

