

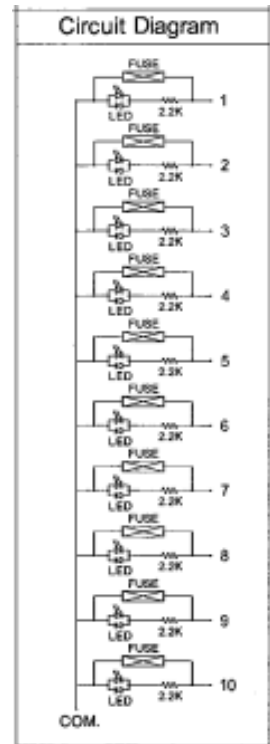

Data Sheet

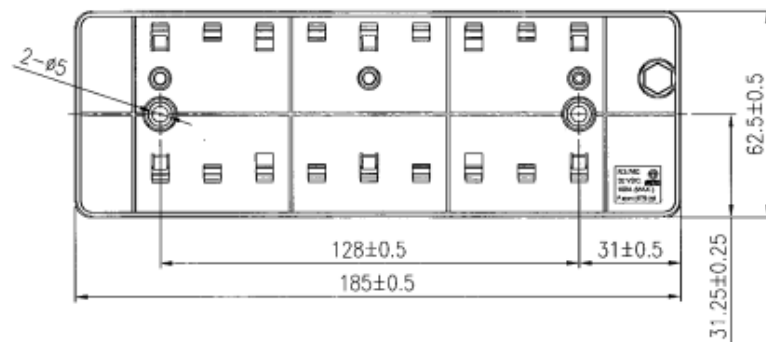
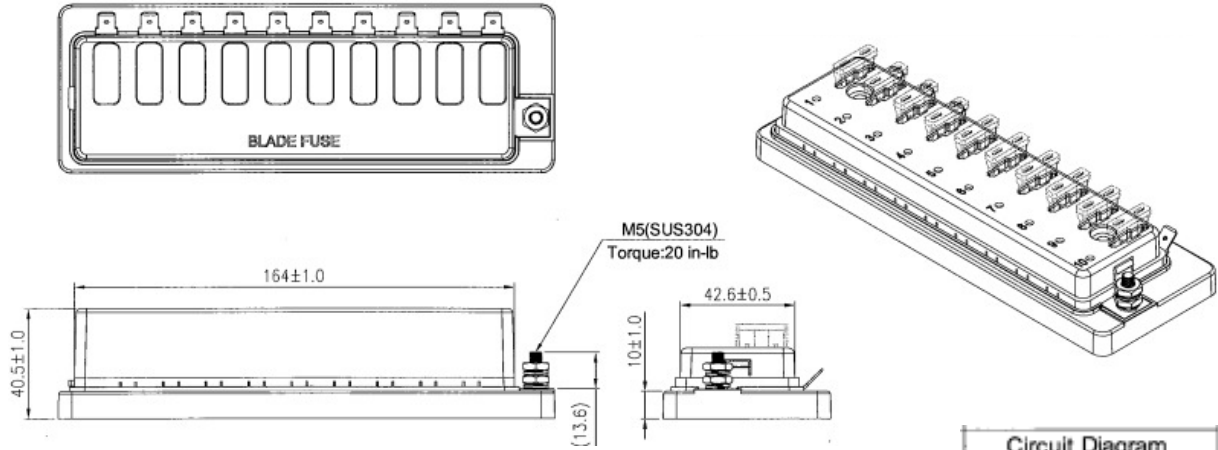

Material :
 Cover : PC. (Transparent)
 Housing , Base : PBT. (Black)
 Push Button : POM. (White)
 Terminal : Tinned copper

Notes :
 1. Rating 100A max. tested by
 4 pcs. 25A load.
 2. Tolerance ±1.0 except noticed

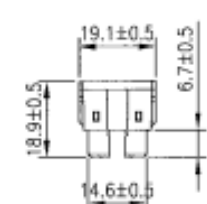
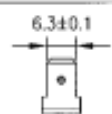
Voltage (Max.)	32 VDC (15 VDC).	Mounting Holes		Blade Fuse Dim.	
Input Terminal Rating	M5 threaded studs (100A max.)	Terminal Dim.			
Output Terminal Rating	30A max. per circuit				
Connection Pad Option Available	Input wire size : #4-6 AWG.				
	Output wire size : #12-16 AWG.				
Fuse Specifications	For Blade Fuses Used Only				
Torque Rating	20 in-lb (2.25Nm) max.				
Temperature Rating	-20 °C to 85 °C				