

Il fornitore e' tenuto a richiedere le prescrizioni riguardanti la simbologia sulle dimensioni. Il simbolo e copia della specifica accettazione materiali n. 83.0117.00. Il simbolo si riferisce alle zone/quote modificate. The supplier is obliged to request the prescription regarding symbols on the dimensions and a copy of the specification concerning materials acceptance n. 83.0117.00. The symbol refers to modified area/dimensions.

Questo documento e le informazioni in esso contenute sono di proprieta' ELTEK SpA e devono considerarsi di natura riservata. Pertanto ne e' vietato qualsiasi tipo di utilizzo non preventivamente autorizzato da ELTEK SpA. This document and the information in it contained are property of ELTEK SpA and, as such, they are to be considered reserved. Therefore, any reproduction in any form or by any means, without prior written permission of ELTEK SpA, is forbidden.

General tolerances	120+	±.27
	180	
	80+	±.23
	120	
	50+	±.19
	80	
	30+	±.16
	50	
	18+	±.13
	30	
	< 18	±.10
Angles		± 2°

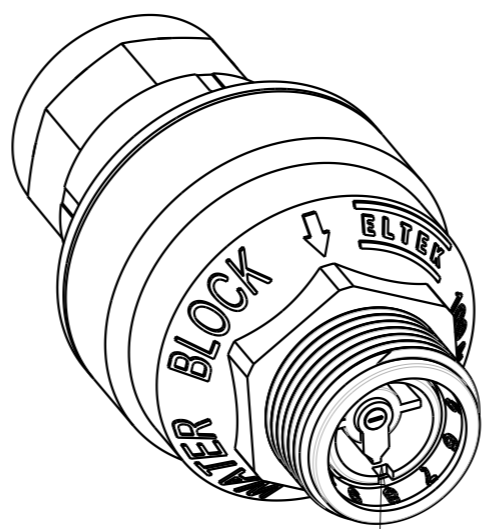
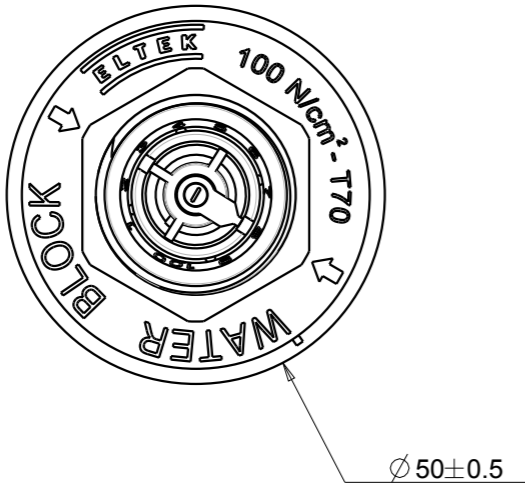
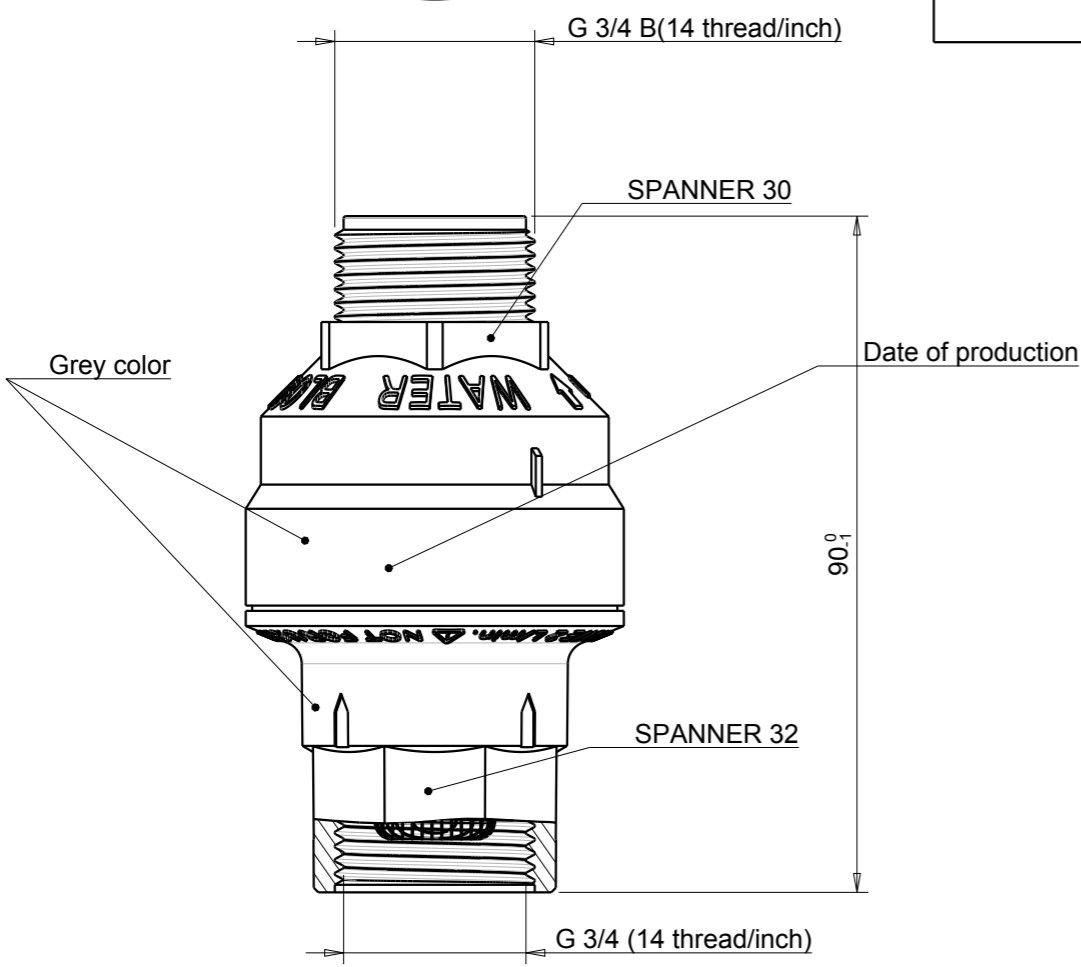

Bush setting position N° 8

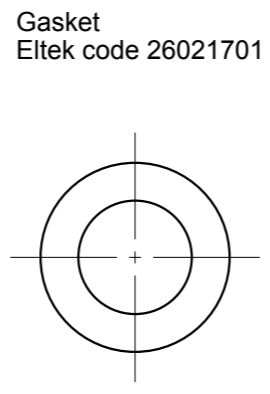

Gasket  
Eltek code 26021701



Regulator  
Eltek code 25.0118.00



Instruction sheet  
Eltek code 15.0150.07



Box dimensions: 50.5X50.5X93  
Eltek code 15.0087.00

Packaging

TECHNICAL FEATURES

BURSTING PRESSURE	500 N/cm <sup>2</sup>
OPERATING CAPACITY	2 ÷ 30 litres/minute
EXTERNAL VOLUMES SETTING	5 ÷ 50 litres 0/-20%
FLUID TEMPERATURE ON CONTINUOUS SERVICE	70° C
MINIMUM WORKING FLOW RATE	2 litres/minute

For technical data refer to technical specification code 82.0041.00

N°200 Water Block in each box 540X280X410

Approvals:  
TUV, WRAS, ETA, DM 174, SINTEF e PZH



Rev	Modification Description	Date	By	Weight [g]:	73.0
Drawing Size	First angle projection	Material	Replace		
A3		-	10.0041.XX.01		
 ELTEK S.p.A. - Casale Monf. ITALY		Colour	Code		
Description		WATERBLOCK WITH GASKET		10.0041.04.00	