



HUMIDITY SENSOR WITH INTEGRATED TEMPERATURE SENSOR WSEN-HIDS USER MANUAL

2525020210001

VERSION 1.3

DECEMBER 8, 2020

Revision history

Manual version	Product version	Notes	Date
1.0	1.0	<ul style="list-style-type: none"> Initial release of the manual 	September 2020
1.1	1.0	<ul style="list-style-type: none"> Temperature measurement range is changed in chapter 2.2 	October 2020
1.2	1.0	<ul style="list-style-type: none"> Slave address of the humidity sensor changed 	October 2020
1.3	1.0	<ul style="list-style-type: none"> I²C multiple byte read operation chapter added Chapter 7.2: Flow chart updated Chapter 9: Sensor output data updated 	December 2020

Abbreviations

Abbreviation	Description
BDU	Block update data
DRDY	Data ready
ESD	Electrostatic discharge
FIFO	First-in first-out
I ² C	Inter integrated circuit
LGA	Land grid array
LSB	Least significant bit
MEMS	Micro-Electro Mechanical system
MSB	Most significant bit
ODR	Output data rate
PCB	Printed circuit board
SPI	Serial peripheral interface

Contents

1	Product description	6
1.1	Introduction	6
1.2	Applications	6
1.3	Sensor features	6
1.4	Block diagram	7
1.5	Ordering information	7
2	Sensor and electrical specifications	8
2.1	Humidity sensor specifications	8
2.2	Temperature sensor specifications	8
2.3	Electrical specifications	9
2.4	Absolute maximum rating	9
2.5	General information	10
3	Pinning description	11
4	Application circuit	12
5	Digital interface	13
5.1	General characteristics	13
5.2	<i>SDA</i> and <i>SCL</i> logic levels	14
5.3	Communication phase	14
5.3.1	Idle state	14
5.3.2	START(S) and STOP(P) condition	14
5.3.3	Data validity	14
5.3.4	Byte format	15
5.3.5	Acknowledge (ACK) and No-Acknowledge (NAACK)	15
5.3.6	Slave address for the sensor	15
5.3.7	Read/Write operation	16
5.4	I ² C Multiple bytes read operation	17
5.5	I ² C timing parameters	18
6	Serial Peripheral Interface (SPI)	19
6.1	Data transfer	20
6.2	Communication modes	20
6.3	Sensor SPI Communication	21
6.3.1	SPI write operation	22
6.3.2	SPI read operation	22
6.3.3	SPI timing parameters	23
7	Quick start guide	24
7.1	Communication check	24
7.2	Sensor in operation	25
8	Operating modes	26
8.1	Continuous mode	27
8.2	One shot mode	27

9	Sensor output data	28
9.1	Humidity sensor	28
9.2	Steps to calculate humidity output value	28
9.3	Temperature sensor	29
9.4	Steps to compute temperature output value	29
10	Sensor register mapping	31
10.1	Calibration Register mapping	32
11	Register description	33
11.1	Device_ID (0x0F)	33
11.2	Average (0x10)	33
11.3	CTRL_1 (0x20)	34
	11.3.1 Block data update (BDU)	34
11.4	CTRL_2 (0x21)	35
	11.4.1 BOOT	35
	11.4.2 Heater	35
11.5	CTRL_3 (0x22)	36
11.6	STATUS (0x27)	36
11.7	H_OUT_L (0x28)	37
11.8	H_OUT_H (0x29)	37
11.9	T_OUT_L (0x2A)	37
11.10	T_OUT_H (0x2B)	38
12	Handling humidity sensor	39
13	Physical dimensions	40
13.1	Module drawing	40
13.2	Footprint	41
14	Manufacturing information	42
14.1	Moisture sensitivity level	42
14.2	Soldering	42
	14.2.1 Reflow soldering	42
	14.2.2 Cleaning and washing	44
	14.2.3 Potting and coating	44
	14.2.4 Storage conditions	44
	14.2.5 Handling	44
15	Important notes	46
15.1	General customer responsibility	46
15.2	Customer responsibility related to specific, in particular safety-relevant applications	46
15.3	Best care and attention	46
15.4	Customer support for product specifications	46
15.5	Product improvements	47
15.6	Product life cycle	47
15.7	Property rights	47
15.8	General terms and conditions	47

16 Legal notice	48
16.1 Exclusion of liability	48
16.2 Suitability in customer applications	48
16.3 Usage restriction	48
17 License terms for Würth Elektronik eiSos GmbH & Co. KG sensor product software and source code	50
17.1 Limited license	50
17.2 Usage and obligations	50
17.3 Ownership	51
17.4 Disclaimer of warranty	51
17.5 Limitation of liability	51
17.6 Applicable law and jurisdiction	51
17.7 Severability clause	52
17.8 Miscellaneous	52

1 Product description

1.1 Introduction

The humidity sensor is a 16-bit digital ultra-low-power and high-performance sensor with digital output interface. It measures relative humidity from 0 to 100% rH with an output data rate of 1 Hz, 7 Hz and 12.5 Hz. It is embedded with a temperature sensor for ambient temperature measurement. The sensor is fully calibrated and no further calibration is required. The dimension of the sensor is 2.0 mm×2.0 mm×0.9 mm. It is available in land grid array package (LGA).

1.2 Applications

- HVAC systems
- Home and building automation
- Goods and asset tracking
- Air conditioners
- Refrigerators

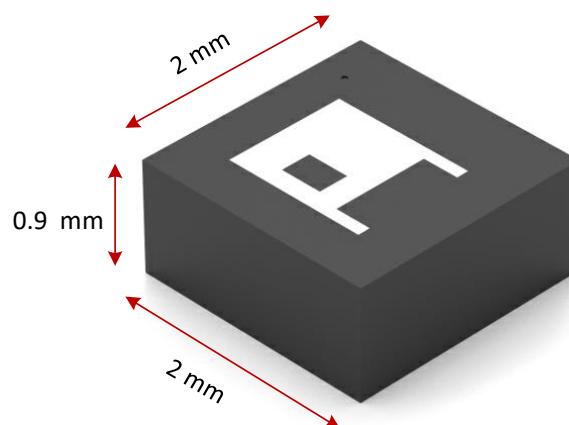

1.3 Sensor features

- Humidity measurement range : 0 to 100 % rH
- Humidity noise : 0.35 rH % RMS
- Temperature measurement range : -40 to +120 °C
- Temperature noise : 0.03 °C RMS
- Output data rate : 1 Hz, 7 Hz and 12.5 Hz
- Operating modes : Continuous mode and one-shot mode
- Current consumption : 8.9µA @ODR 1Hz
- Communication interface : I²C, SPI and Interrupt pin

1.4 Block diagram

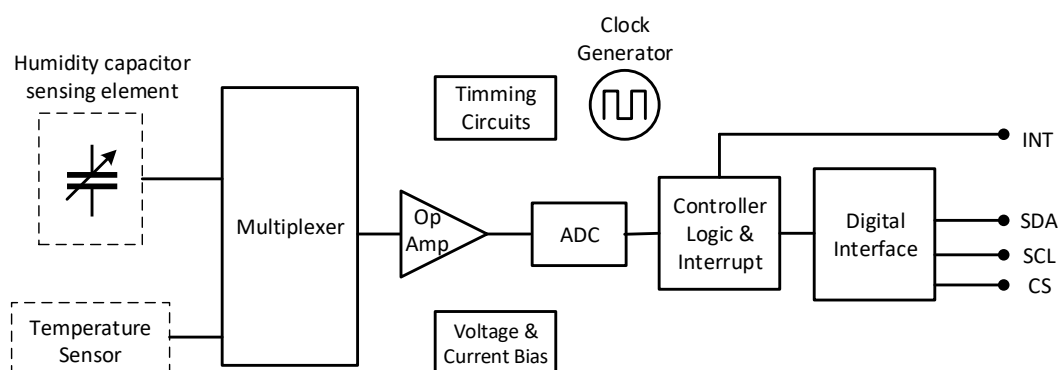

Figure 1: Block diagram

The sensor is a MEMS based capacitive humidity sensor with an integrated ASIC. MEMS sensing element is a planar fringed capacitor with a dielectric polymer which absorbs or releases water with proportional to the relative humidity in the environment. A silicon based temperature sensor is integrated in the same package. ASIC comprises of multiplier, operational amplifier, analog-to-digital converter and other signal conditioning blocks like controller logics and interrupts. ASIC converts the analog signal from the both humidity and temperature sensing element into a 16-bit digital humidity and temperature values. The sensor is factory calibrated for both humidity and temperature measurements. The trimming parameters are stored in on-chip flash memory. When the sensor is powered on, these trimming parameters are loaded from the flash memory to the registers. Hence, no further calibration is required for humidity and temperature values.

1.5 Ordering information

WE order code	Temperature Range	Description
2525020210001	-40 °C to +120 °C	Tape & reel packaging

Table 1: Ordering information

2 Sensor and electrical specifications

T=25 °C, supply voltage VDD = 3.3V, unless otherwise stated.

2.1 Humidity sensor specifications

Parameters	Symbol	Test conditions	Min. ¹	Typ.	Max. ¹	Unit
Measurement range	H _{RANGE}		0		100	% rH
Resolution	RES _H			16		bits
Sensitivity	SEN _H			0.004		% rH/digit
Accuracy	H _{ACC}	20% rH to 80% rH		±3.5		% rH
		0% rH to 100% rH		±5		% rH
Noise(RMS)	H _{NOISE}	Internal average: 32 samples ²		0.35		% rH RMS
Hysteresis	HYS _H			±1		% rH
Long-term drift	H _{DRIFT}	20% rH to 80% rH		0.5		% rH/Year
Response time	H _{STEP}	Step response time of 63%		10		s
Output data rate	ODR		1		12.5	Hz

Table 2: Humidity sensor specification

¹ Minimum and maximum values are based on characterization at 3σ.

² Default setting

2.2 Temperature sensor specifications

Parameters	Symbol	Test conditions	Min. ¹	Typ.	Max. ¹	Unit
Measurement range	T _{RANGE}		-40		+120	°C
Resolution	RES _T			16		bits
Noise(RMS)	T _{NOISE}	Internal average: 16 samples ²		0.03		°C RMS
Sensitivity	SEN _T			0.016		°C/digit
Absolute accuracy	T _{ACC_ABS}	15°C to 40°C		±0.5		°C
		0°C to 60°C		±1		°C

Table 3: Temperature sensor specification

¹ Minimum and maximum values are based on characterization at 3σ.

² Default setting

2.3 Electrical specifications

Parameters	Symbol	Test conditions	Min. ¹	Typ.	Max. ¹	Unit
Operating supply voltage	V_{DD}		1.7	3.3	3.6	V
Current consumption	I_{DD}	ODR 1 Hz		8.9		μA
Current consumption in power down mode	I_{DD_PD}			0.5		μA

Table 4: Electrical specification

¹ Minimum and maximum values are based on characterization at 3σ .

2.4 Absolute maximum rating

Parameter	Symbol	Test conditions	Min. ¹	Max. ¹	Unit
Input voltage V_{DD} pin	V_{DD}		-0.3	4.8	V
Input voltage <i>SDA</i> , <i>SCL</i> & <i>CS</i>	V_{IN} pins		-0.3	$V_{DD_IO} + 0.3$	V

Table 5: Absolute maximum rating

¹ Minimum and maximum values are based on characterization at 3σ .



Supply voltage on any pin should never exceed 4.8 V

2.5 General information

Parameters	Values
Operating temperature	-40 °C to +120 °C
Storage temperature	-40 °C to +125 °C
Communication interface	I ² C & SPI
Moisture sensitivity level (MSL)	3
Electrostatic discharge protection(HBM)	2 kV

Table 6: General information



The device is susceptible to damage by electrostatic discharge (ESD). Always use proper ESD precautions when handling. Improper handling of the device can cause performance degradation or permanent damage to the part



For better performance, the recommended storage condition for the humidity sensor is 10 °C to 40 °C with 20% rH to 60% rH

3 Pinning description

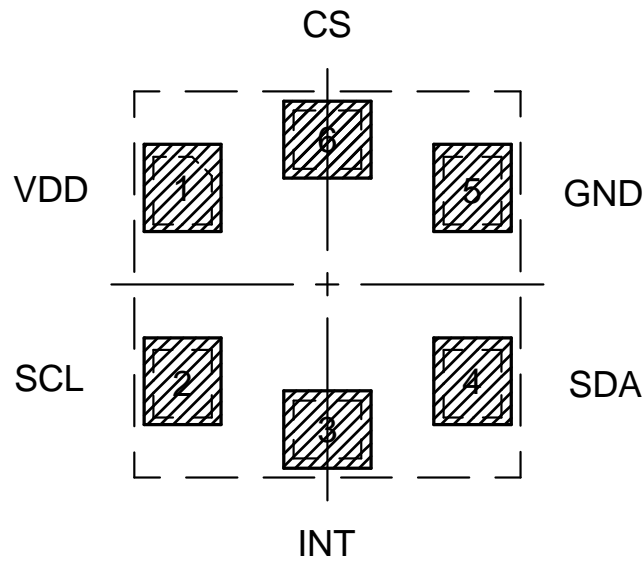

Figure 2: Pinout (top view)

No	Function	Description	Input/Output
1	<i>VDD</i>	Positive supply voltage	Supply
2	<i>SCL</i>	I ² C serial clock	Input
3	<i>INT</i>	Data ready output signal	Output
4	<i>SDA</i>	I ² C / SPI: serial data input/output	Input/Output
5	<i>GND</i>	Negative supply voltage	Supply
6	<i>CS</i>	I ² C/SPI enable/disable	Input

Table 7: Pin description

4 Application circuit

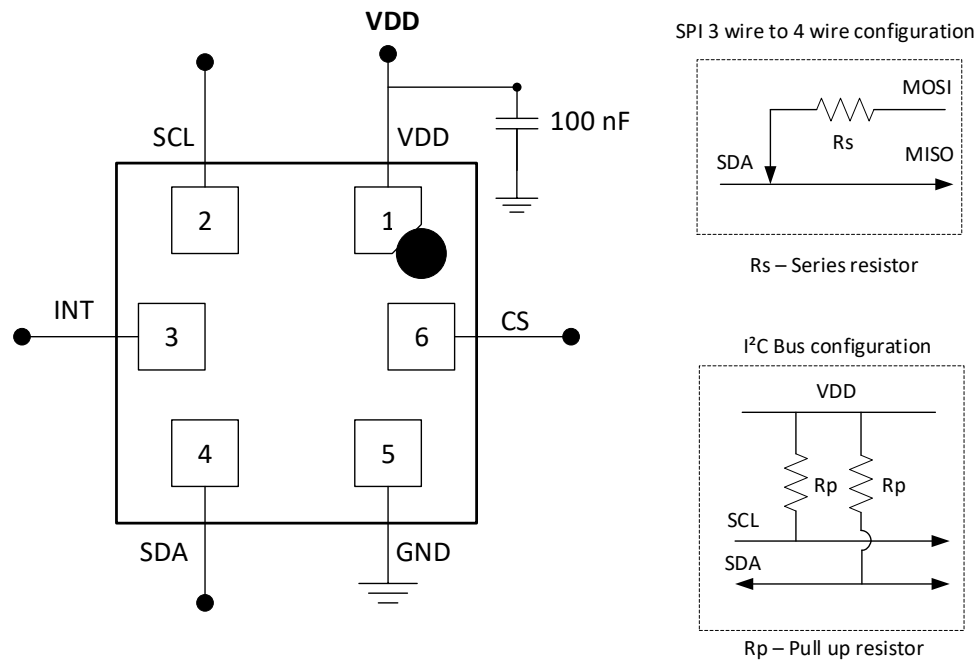

Figure 3: Electrical connection (top view)

A positive supply voltage is applied to the sensor through VDD pin and negative voltage to GND . The decoupling capacitor of 100 nF in parallel is highly recommended to prevent the voltage ripples on the VDD line. It should be placed as close as possible to the VDD pin. The CS pin shall be connected to VDD_{IO} in order to enable the I²C communication interface. For SPI communication, the CS pin shall be connected to master side CS pin for active start and stop SPI communication. The pull up resistors R_p for I²C communication interface should be connected parallel between supply voltage VDD and SCL and SDA pins.

Depending on the internal resistance of I²C pins at the master side, the pull up resistors R_p can be selected for proper rise and fall time of the digital signals. The 3-pin to 4-pin SPI configuration can be configured as mentioned in the figure 3.

5 Digital interface

The humidity sensor supports standard I²C (Inter-IC) bus protocol. Further information of the I²C interface can be found at <https://www.nxp.com/docs/en/user-guide/UM10204.pdf>. I²C is a serial 8-bit protocol with two-wire interface, which supports communication between different ICs. For example, between the microcontroller and other peripheral devices.

5.1 General characteristics

A serial data line (*SDA*) and a serial clock line (*SCL*) are required for the communication between the devices connected via I²C bus. Both *SDA* and *SCL* lines are bidirectional. The output stages of devices connected to the bus must have an open-drain or open-collector. Hence, the *SDA* and *SCL* lines are connected to a positive supply voltage via pull-up resistors. In I²C protocol, the communication is realized through master-slave principle. The master device generates the clock pulse, a start command and a stop command for the data transfer. Each connected device on the bus is addressable via a unique address. Master and slave can act as a transmitter or a receiver depending upon whether the data needs to be transmitted or received.



The sensor behaves like a slave device on the I²C bus

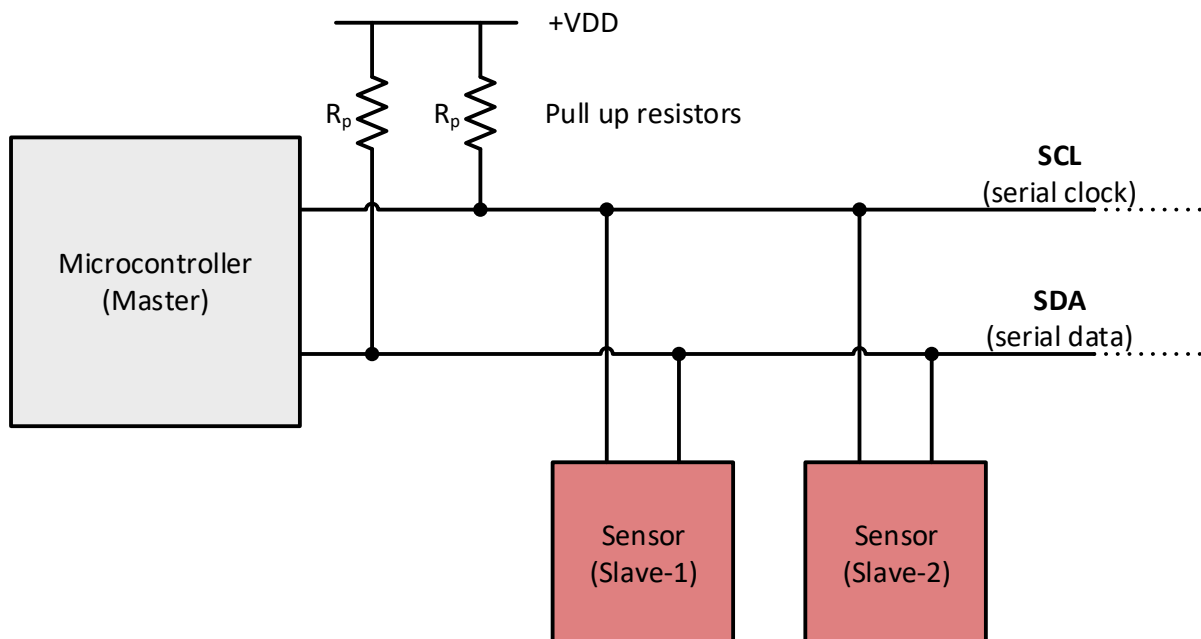

Figure 4: Master-slave concept

5.2 SDA and SCL logic levels

The positive supply voltage to which *SDA* and *SCL* lines are pulled up (through pull-up resistors), in turn determines the high level input for the slave devices. The sensor has separate supply voltage *VDD_IO* for the *SDA* and *SCL* lines. The logic high '1' and logic low '0' levels for the *SDA* and *SCL* lines then depend on the *VDD*.

5.3 Communication phase

5.3.1 Idle state

During the idle state, the bus is free and both *SDA* and *SCL* lines are in logic high '1' state.

5.3.2 START(S) and STOP(P) condition

Data transfer on the bus starts with a START command, which is generated by the master. A start condition is defined as a high-to-low transition on the *SDA* line while the *SCL* line is held high. The bus is considered busy after the start condition.

Data transfer on the bus is terminated with a STOP command, which is also generated by the master. A low-to-high transition on the *SDA* line, while the *SCL* line being high is defined as a STOP condition. After the stop condition, the bus is again considered free and is in idle state. Figure 5 shows the I²C bus START and STOP conditions.

Master can also send a REPEATED START (SR) command instead of STOP command. REPEATED START condition is same as the START condition.

5.3.3 Data validity

After the start condition, one data bit is transmitted with each clock pulse. The transmitted data is only valid when the *SDA* line data is stable (high or low) during the high period of the clock pulse. High or low state of the data line can only change when the clock pulse is in low state.

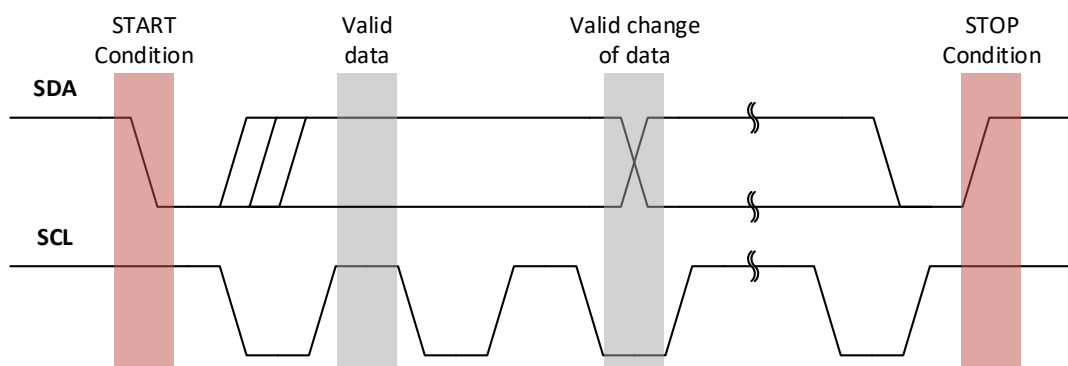

Figure 5: Data validity, START and STOP condition

5.3.4 Byte format

Data transmission on the *SDA* line is always done in bytes, with each byte being 8-bits long. Data is transmitted with the most significant bit (MSB) followed by other bits.

If the slave cannot receive or transmit another complete byte of data, it can force the master into a wait state by holding *SCL* LOW. Data transfer continues when the slave is ready which is indicated by releasing the *SCL* pin.

5.3.5 Acknowledge (ACK) and No-Acknowledge (NAACK)

Each byte transmitted on the data line must follow an Acknowledge bit. The receiver (master or slave) generates an Acknowledge signal to indicate that the data byte was received successfully and ready to receive next data byte.

After one byte is transmitted, the master generates an additional Acknowledge clock pulse to continue the data transfer. The transmitter releases the *SDA* line during this clock pulse so that the receiver can pull the *SDA* line to low state in such a way that the *SDA* line remains stable low during the entire high period of the clock pulse. It is considered as an Acknowledge signal.

If the receiver does not want to receive any further byte, it will not pull down the *SDA* line and it remains in stable high state during the entire clock pulse. It is considered as a No-Acknowledge signal and the master can generate either a stop condition to terminate the data transfer or a repeated start condition to initiate a new data transfer.

5.3.6 Slave address for the sensor

The slave address is transmitted after sending the start condition. Each device on the I²C bus has a unique address. Master selects the slave by sending corresponding slave address after the start condition. A slave address is a 7 bits long followed by a Read/Write bit.

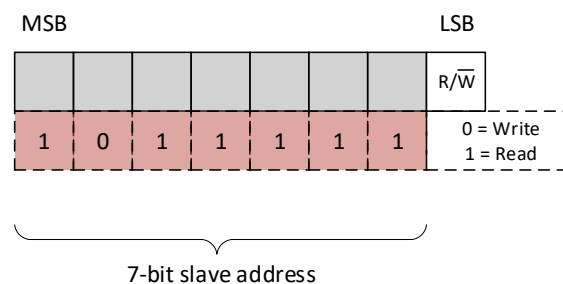

Figure 6: Slave address format

The 7-bit slave address of the humidity sensor is 1011111b. The R/W bit determines the data direction. '0' indicates a write operation (transmission from master to slave) and a '1' indicates a read operation (data request from slave).

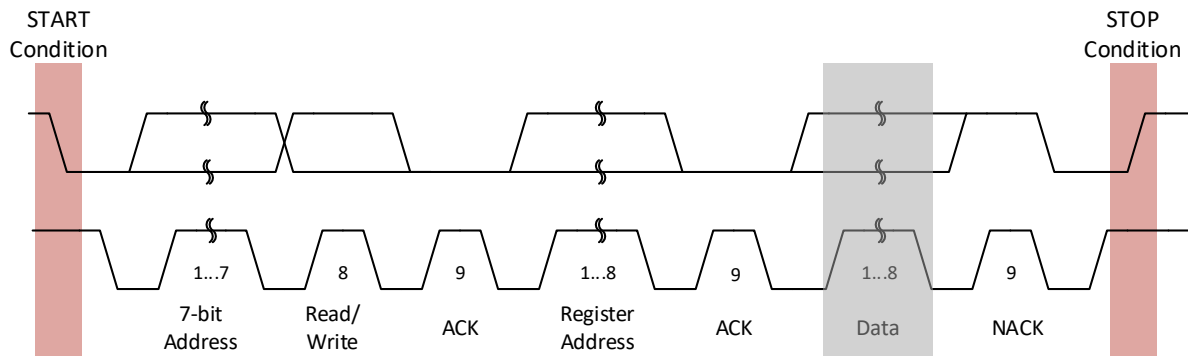

Figure 7: Complete data transfer



7-bit slave address of the humidity sensor is 1011111b.

5.3.7 Read/Write operation

a) I²C write: Master writing data to slave

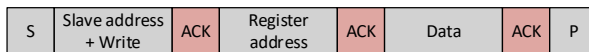

b) I²C read: Master reading multiple data bytes from slave

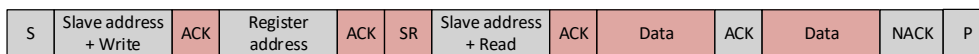

- Transmission from master to slave
- Transmission from slave to master
- S START condition
- P STOP condition
- ACK Acknowledge
- NACK No acknowledge
- SR Repeated start condition

Figure 8: Write and read operations of the sensor

Once the slave-address and data direction bit is transmitted, the slave acknowledges the master. The master transmits the next byte, which must be a register-address of the sensor. It indicates the address of the register where data needs to be written to or read from.

After receiving the register address, the slave sends an Acknowledgement (ACK). If the master is still writing to the slave (R/W bit = 0), it will transmit the data to slave in the same direction. If the master wants to read from the addressed register (R/W bit =1), a repeated start (SR) condition must be transmitted to the slave. Master acknowledges the slave after receiving each data byte. If the master no longer wants to receive further data from the slave, it would send No-Acknowledge (NACK). Afterwards, master can send a STOP condition to terminate the data transfer. Figure 8 shows the writing and reading procedures between the master and the slave device (sensor).

5.4 I²C Multiple bytes read operation

In order to read multiple bytes incrementing the register address, it is necessary to assert the most significant bit of the sub-address field (output register address). The bit [7] must be equal to 1 while bit [6-0] represents the address of the first register to be read. Here is an example of how to read 4 bytes of data from output registers by requesting the data only from 0x28.

- To read multiple bytes from the output registers 0x28 to 0x2B, the first register address must be changed from 0x28 (b0010 1000) to 0xA8(b1010 1000 (MSB is changed from '0' to '1')).
- After sending I²C address, start with reading from the register 0xA8 and request 4 bytes to read.
- The received 4 bytes gives the content from registers 0x28 to 0x2B.



There is no auto increment bit (enable/disable) implemented in the control register for multiple bytes of read.

5.5 I²C timing parameters

Parameter	Symbol	Standard mode		Fast mode		Unit
		Min	Max	Min	Max	
<i>SCL</i> clock frequency	f_{SCL}	0	100	0	400	kHz
LOW period for <i>SCL</i> clock	t_{LOW_SCL}	4.7		1.3		μ s
HIGH period for <i>SCL</i> clock	t_{HIGH_SCL}	4.0		0.6		μ s
Hold time for START condition	t_{HD_S}	4		0.6		μ s
Setup time for (repeated) START condition	f_{SCL}	4.7		0.6	400	μ s
<i>SDA</i> setup time	t_{SU_SDA}	250		100		ns
<i>SDA</i> data hold time	t_{HD_SDA}	0	3.45	0	0.9	μ s
Setup time for STOP condition	t_{SU_P}	4		0.6		μ s
Bus free time between STOP and START condition	t_{BUF}	4.7		1.3		μ s

Table 8: I²C timing parameters

6 Serial Peripheral Interface (SPI)

Serial Peripheral Interface (SPI) is a synchronous serial communication bus system for the communication between host microcontroller and other peripheral ICs such as ADCs, EEPROMs, sensors, etc. SPI is a full-duplex master-slave based interface allowing the communication to happen in both directions simultaneously. The data from the master or the slave is synchronized either on the rising or falling edge of clock pulse. SPI can be either 4-wire or 3-wire interface. 4-wire interface consists of two signal lines and two data lines. All of these bus lines are unidirectional.

1. Clock (SCL)
2. Chip select (CS)
3. Master out, slave in (MOSI)
4. Master in, slave out (MISO)

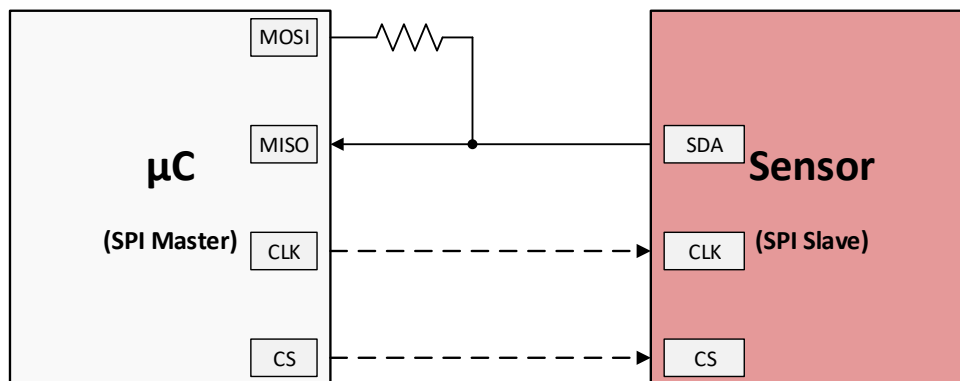

Figure 9: SPI Interface

Master generates the clock signal and is connected to all slave devices. Data transmission between the master and slaves is synchronized to the clock signal generated by the master.

One master can be connected to one or more slave devices. Each slave device is addressed and controlled by the master via individual chip select (CS) signals. CS is controlled by the master and is normally an active low signal.

MOSI and MISO are data lines. MOSI transmits data from the master to the slave. MISO transmits data from the slave to the master.



The humidity sensor supports only 3-wire SPI communication.

6.1 Data transfer

Communication begins when the master selects a slave device by pulling the CS line to LOW. The clock and data lines (MOSI/MISO) are available for the selected slave device. Data stored in the specific shift registers are exchanged synchronously between master and the slave through MISO and MOSI lines. The data transmission is over when the chip select line is pulled up to the HIGH state. 4-wire SPI uses both data lines for the synchronous data exchange in both the direction. 3-wire SPI shares a single data line for the data transfer, where the master and slave alternate their transmitter and receiver roles synchronously.

6.2 Communication modes

In SPI, the master can select the clock polarity (CPOL) and clock phase (CPHA). The CPOL bit sets the polarity of the clock signal during the idle state. The CPHA bit selects the clock phase. Depending on the CPHA bit, the rising or falling clock edge is used to sample and shift the data. Depending on the CPOL and CPHA bit selection in the SPI control registers, four SPI modes are available as per table 9. In order to ensure proper communication, master and the slave must be set to same communication modes.

CPOL	CPHA	Description
0	0	Clock polarity LOW in idle state; Data sampled on the rising clock edge
0	1	Clock polarity LOW in idle state; Data sampled on the falling clock edge
1	1	Clock polarity HIGH in idle state; Data sampled on the falling clock edge
1	0	Clock polarity HIGH in idle state; Data sampled on the rising clock edge

Table 9: SPI communication modes

6.3 Sensor SPI Communication

3-Wire SPI of this sensor uses following lines: SDA (data input, MOSI), SCL (serial clock) and CS (chip select). For more information, please refer to pin description in the section 3.

CS is pulled LOW by the master at the start of communication. The SCL polarity is HIGH in the idle state (CPOL = 1). The data lines (SDA & SAO) are sampled at the falling clock edge and latched at the rising clock edge (CPHA = 1). Data is transmitted with MSB first and the LSB last.

SPI read and write operations are completed in 2 or more bytes (multiple of 16 or more clock pulses). Each block consists of a register address byte and a data byte. The first byte is the register address. In the SPI communication, the register address is specified in the 7-bits and the MSB of the register address is used as an SPI read/write bit (Figure 10). When R/W is '0', the data is written on to the sensor. When '1', the data is read from the sensor.

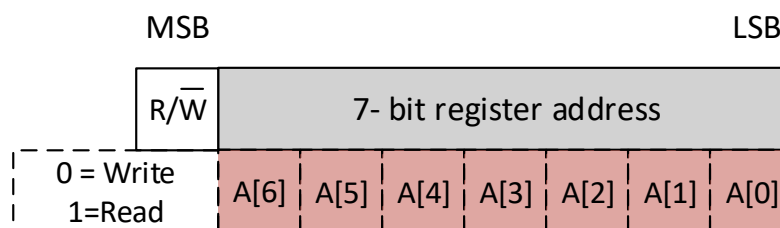

Figure 10: SPI register address

The next bytes of data, depending on the R/W bit, is either written to or read from the indexed register. Figure 11 shows the complete SPI data transfer protocol.



The sensor supports 3-wire SPI communication uses *SDA* pin for both data read and write operations. Communication protocol remains the same.

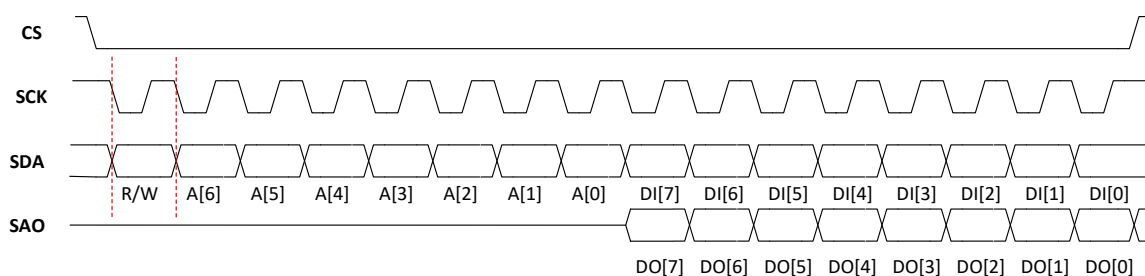

Figure 11: 4-wire SPI data transfer (CPOL = 1, CPHA = 1)

6.3.1 SPI write operation

The write operation starts with the CS = LOW and sending the 7-bit register address with R/W bit = '0' (write command). Next byte is the data byte that is the data to be written to the indexed register. Several write command pairs can be sent without raising the CS back to HIGH. The operation is ended with CS = HIGH. The SPI write protocol is shown in the figure 12.

Start	R/ \bar{W}	Register address							Data to be written							Stop	
CS = LOW	0	A[6]	A[5]	A[4]	A[3]	A[2]	A[1]	A[0]	DI [7]	DI [6]	DI [5]	DI [4]	DI [3]	DI [2]	DI [1]	DI [0]	CS = HIGH

Figure 12: SPI write protocol

6.3.2 SPI read operation

The read operation starts with the CS = LOW and sending the 7-bit register address with R/W bit = '1' (read command). Data is sent out from the sensor through the SDA line. The SPI read protocol is shown in the figure 13.

Start	R/ \bar{W}	Register address							Data from indexed register							Stop	
CS = LOW	1	A[6]	A[5]	A[4]	A[3]	A[2]	A[1]	A[0]	DO [7]	DO [6]	DO [5]	DO [4]	DO [3]	DO [2]	DO [1]	DO [0]	CS = HIGH

Figure 13: SPI read protocol

6.3.3 SPI timing parameters

Table 10 shows general SPI timing parameters. They are subject to VDD and the operating temperature.

Parameter	Symbol	Min	Max	Unit
SCL clock frequency	f_{SCL}		10 ⁽¹⁾	MHz
SPI clock cycle	t_{SCL}	100		ns
CS setup time	t_{SU_CS}	6		ns
CS hold time	t_{h_CS}	6		ns
SDA input setup time	t_{SU_SDA}	5		ns
SDA input hold time	t_{h_SDA}	15		ns
SAO valid output time	t_{v_SAO}		50	ns
SAO output hold time	t_{h_SAO}	9		ns
SAO output disable time	t_{dis_SAO}		50	ns

Table 10: SPI timing parameters

1. Recommended maximum SPI clock frequency for $ODR \leq 50$ Hz is 8 MHz

7 Quick start guide

This chapter describes the sensor communication check and operation sequence of the humidity sensor.

7.1 Communication check

After proper powering of the sensor, the first step is to check the communication of the sensor with an I²C or SPI digital interface. It can be verified by reading the *DEVICE_ID* register (0x0F). If the value from the *DEVICE_ID* register (0x0F) is 0xBC, then communication from master to sensor is successful.

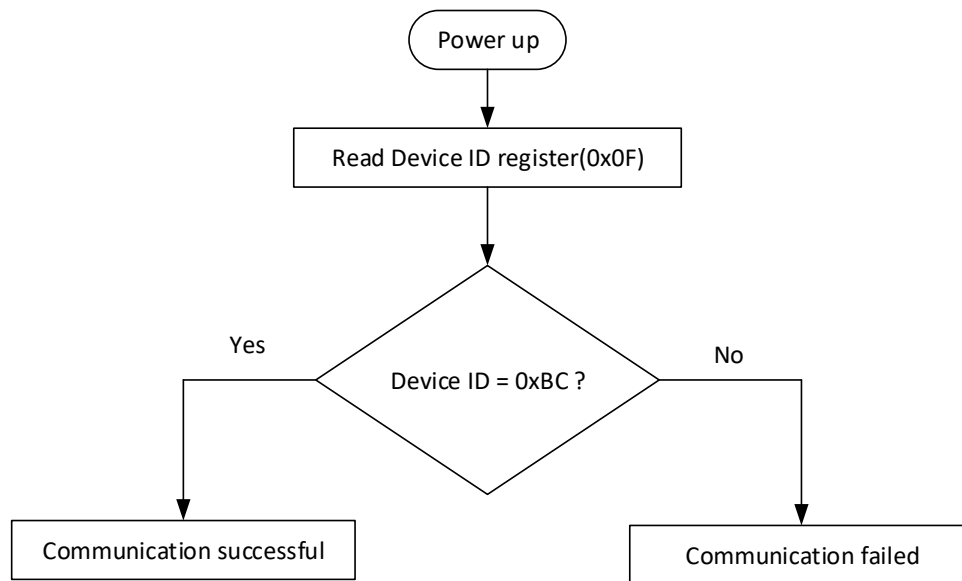

Figure 14: Communication check

7.2 Sensor in operation

The following flow chart is an initialization example to operate the sensor in continuous mode with output data rate of 1 Hz.

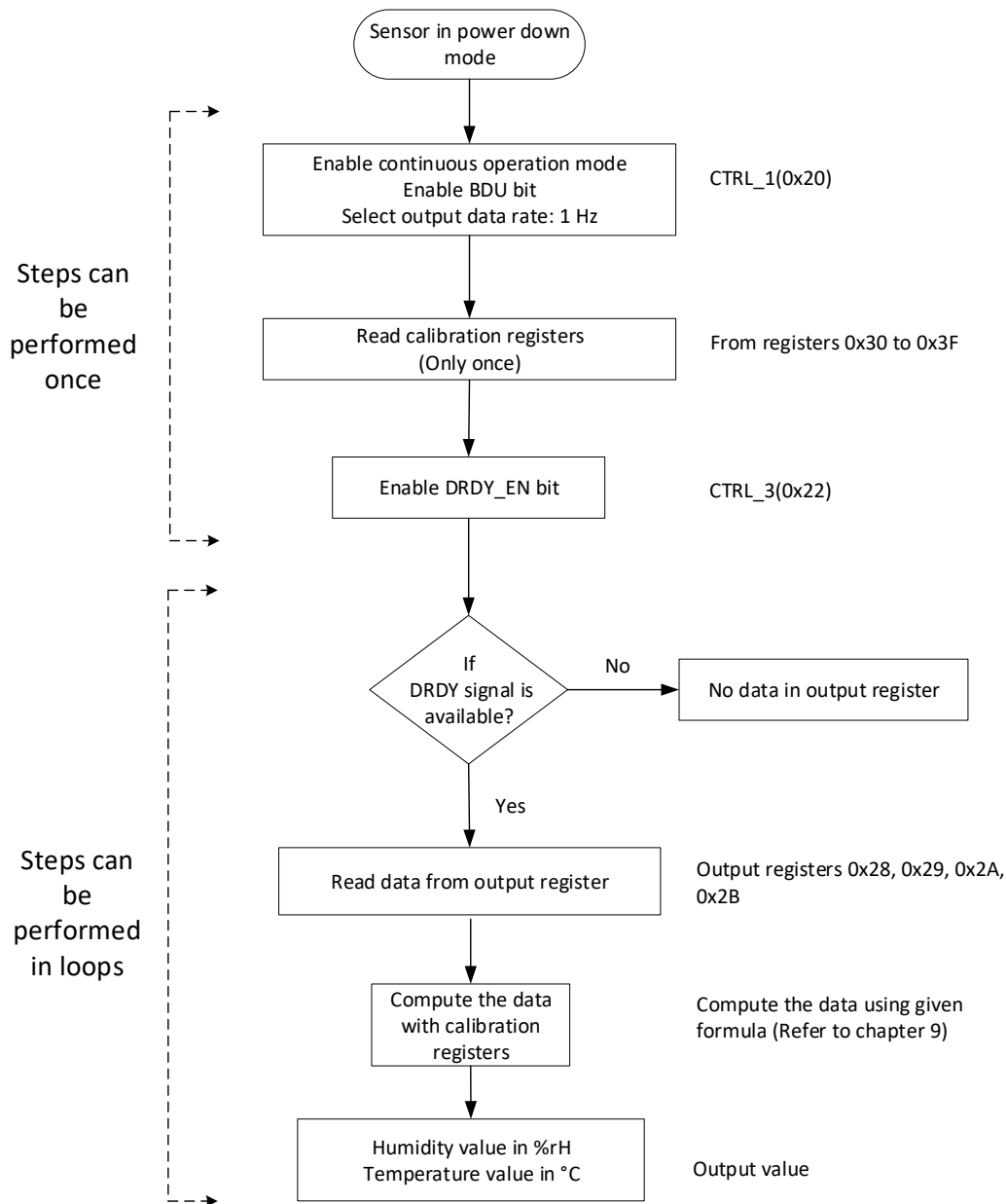

Figure 15: Sensor in operation

The initialization of the sensor can be performed by selecting the operation mode and output data rate. After initialization of the sensor, it is recommended to check the availability of data samples using DRDY signal at *INT* pin.

8 Operating modes

The humidity sensor can be operated in two different modes. Operating modes can be selected by PD bit and ODR[1:0] bits in the *CTRL_1* register(0x20) and ONE SHOT bit in the *CTRL_2* register(0x21).

- Continuous mode
- One shot mode

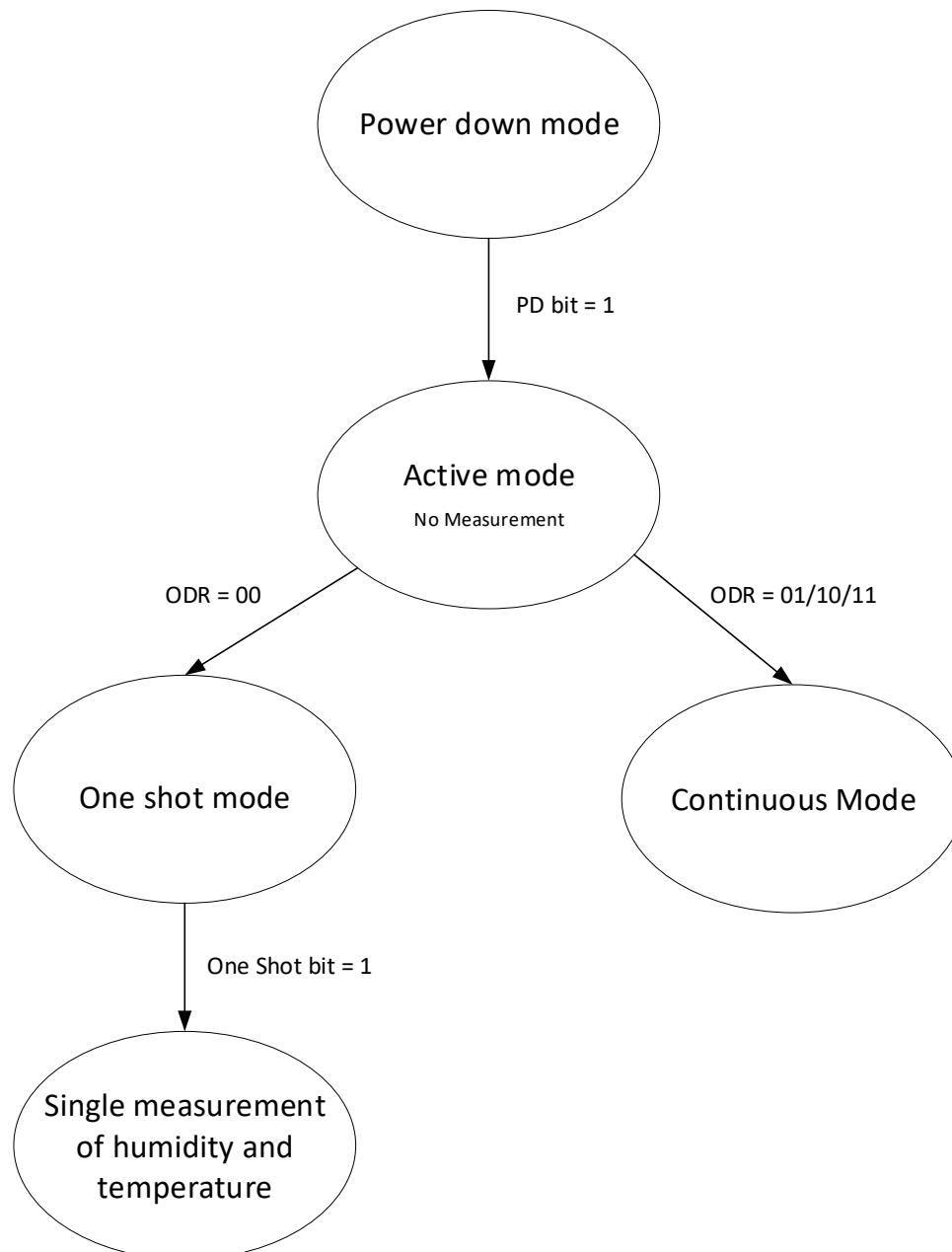

Figure 16: Operating modes

By default after powering up, the sensor goes to power down mode. In power down mode, all internal blocks are turned off to minimize the power consumption. After selecting one of the two operating mode, the sensor is in active measurement state depending on the output data rate.

8.1 Continuous mode

In the continuous mode, the sensor is in active measurement state for humidity and temperature values. The humidity and temperature values are available at a rate of selected output data rate in the table 11.

Three possible output data rates in the continuous mode are mentioned in table 11.

ODR[1:0]	Output data rate
00	One shot mode
01	1 Hz
10	7 Hz
11	12.5 Hz

Table 11: Output data rate

8.2 One shot mode

One shot mode can be used only when the humidity and temperature values are necessary instead of continuous measurement value. ONE SHOT bit in the *CTRL_2* register(0x21) is used to start a new measurement. The humidity and temperature output values are acquired and it is available in the output registers when the ONE SHOT bit is set to '1'. After completion of a new measurement for humidity and temperature values, the ONE SHOT bit is set to '0' automatically by the sensor.

9 Sensor output data

9.1 Humidity sensor

The humidity sensor values are obtained from two 8-bit output registers H_OUT_L (0x28) and H_OUT_H (0x29). These two 8-bit values are concatenated to form a 16-bit word, which is represented in 2's complement. The relative humidity value is calculated by linear interpolation method using values from humidity output registers H_OUT_L (0x28) and H_OUT_H (0x29) along with calibration registers.

9.2 Steps to calculate humidity output value



Step 1 to step 6 can be performed only once

1. Read the coefficient values from the registers H0_rH_x2 (0x30) and H1_rH_x2 and (0x31)
2. Divide the coefficients by 2 to get H0_rH and H1_rH:
(H0_rh_x2)/2 and (H1_rh_x2)/2
3. Read the values from register 0x36 and 0x37.
4. Concatenate 0x37 & 0x36 to obtain signed 16-bit value of H0_T0_OUT.
5. Read the values from register 0x3A and 0x3B.
6. Concatenate 0x3B & 0x3A to obtain signed 16-bit value of H1_T0_OUT.
7. Read the raw values from humidity output register 0x28 and 0x29.
8. Concatenate 0x29 & 0x28 to obtain 16-bit word of H_T_OUT.
9. Calculate the relative humidity value in rH % using below formula:

$$Humidity = \frac{(H1_rH - H0_rH) \cdot (H_T_OUT - H0_T0_OUT)}{(H1_T0_OUT - H0_T0_OUT)} \quad (1)$$

$$Humidity(\% \text{ relative Humidity}) = Humidity + H0_rH \quad (2)$$

Equation 2 gives the humidity values in %rH. The software drivers must clip output values exceeding the measurement range of the humidity sensor.



WSEN_HIDS humidity sensor SDK is implemented with the above steps. It is available in our website to download for free.

9.3 Temperature sensor

The temperature sensor values are obtained from two 8-bit output registers T_OUT_L (0x2A) and T_OUT_H (0x2B). These two 8-bit values are concatenated to form a 16-bit word, which is represented in 2's complement.

The most significant bit (MSB) of the T_OUT_H register indicates the polarity of the temperature output value.

- If the sign bit is '0', then the value read is positive.
- If the sign bit is '1', then the value read is negative. In this case, take 2's complement of the entire word.

The temperature value is calculated by linear interpolation method using values from the temperature output registers T_OUT_L (0x2A) and T_OUT_H (0x2B) along with calibration registers.

9.4 Steps to compute temperature output value



Step 1 to step 13 can be performed only once

1. Read the coefficient value from the register T1_T0 (0x35) and store it in a variable 'tmp'.
2. Read the coefficient value from the registers T0_degC_x8 (0x32) and store it in a variable 'buffer'.
3. Perform logic AND operation between 'tmp' and 0x03 and left shift by 8 bits.
 $x = ((tmp \& 0x03) \ll 8)$
4. Perform logic OR operation between x and 'buffer' to get T0_degC_x8.
 $T0_degC_x8 = x | buffer$
5. Divide the coefficient by 8 to get T0_degC.
 $T0_degC = (T0_degC_x8)/8$
6. Read the coefficient value from the registers T1_degC_x8 (0x33) and store it in a variable 'buffer'.

7. Perform logic AND operation between 'tmp' and 0x0C and left shift by 6 bits.
 $y = ((tmp \& 0x0C) \ll 6)$
8. Perform logic OR operation between y and 'buffer' to get T1_degC_x8.
 $T1_degC_x8 = y | buffer$
9. Divide the coefficient by 8 to get T1_degC.
 $T1_degC = (T1_degC_x8)/8$
10. Read the values from register 0x3C and 0x3D.
11. Concatenate 0x3D & 0x3C to obtain signed 16-bit value of T0_OUT.
12. Read the values from register 0x3E and 0x3F.
13. Concatenate 0x3F & 0x3E to obtain signed 16-bit value of T1_OUT.
14. Read the raw values from temperature output register 0x2A and 0x2B.
15. Concatenate 0x2B & 0x2A to obtain 16-bit word of T_OUT.
16. Calculate the temperature value in °C using below formula:

$$Temperature = \frac{(T1_degC - T0_degC).(T_OUT - T0_OUT)}{(T1_OUT - T0_OUT)} \quad (3)$$

$$Temperature(degree\ Celsius) = Temperature + T0_degC \quad (4)$$

Equation 4 gives the temperature values in °C.



WSEN_HIDS humidity sensor SDK is implemented with the above steps. It is available in our website to download for free.

10 Sensor register mapping

Register Addr (Hex)	Name	Bit 7	Bit 6	Bit 5	Bit 4	Bit 3	Bit 2	Bit 1	Bit 0	Type	Comments	
0x0F	<i>DEVICE_ID</i>	1	0	1	1	1	1	0	0	R	Device ID of the sensor	
0x10	<i>Average</i>	Reserved ¹		AVG_T[2:0]		AVG_H[2:0]				R/W	Internal average register	
0x20	<i>CTRL_1</i>	PD	Reserved ¹			BDU	ODR[1:0]			R/W	Control registers	
0x21	<i>CTRL_2</i>	BOOT	Reserved ¹				Heater	ONE SHOT		R/W		
0x22	<i>CTRL_3</i>	DRDY_H_L	PP_OD	Reserved ¹		DRDY_EN	Reserved ¹			R/W		
0x27	<i>STATUS</i>	Reserved ¹						H_DA	T_DA		R/W	Status register
0x28	<i>H_OUT_L</i>	H_OUT_L[7:0]									R	Output registers
0x29	<i>H_OUT_H</i>	H_OUT_H[7:0]									R	
0x2A	<i>T_OUT_L</i>	T_OUT_L[7:0]									R	
0x2B	<i>T_OUT_H</i>	T_OUT_H[7:0]									R	
0x30 - 0x3F	<i>Calibration</i>	-									R	Calibration registers

10.1 Calibration Register mapping

Register Addr (Hex)	Name	Format	Bit 7	Bit 6	Bit 5	Bit 4	Bit 3	Bit 2	Bit 1	Bit 0	Type
0x30	<i>H0_rH_x2</i>	u8	H_0[7:0]								R
0x31	<i>H1_rH_x2</i>	u8	H_1[7:0]								R
0x32	<i>T0_degC_x8</i>	u8	T_degC_0[7:0]								R
0x33	<i>T1_degC_x8</i>	u8	T_degC_1[7:0]								R
0x35	<i>T1_T0</i>	u2	Reserved ¹				T_1[1:0]		T_0[1:0]		R
0x36	<i>H0_T0_OUT</i>	s16	H0_T0_OUT_L[7:0]								R
0x37			H0_T0_OUT_H[7:0]								R
0x3A	<i>H1_T0_OUT</i>	s16	H1_T0_OUT_L[7:0]								R
0x3B			H1_T0_OUT_H[7:0]								R
0x3C	<i>T0_OUT</i>	s16	T0_OUT_L[7:0]								R
0x3D			T0_OUT_H[7:0]								R
0x3E	<i>T1_OUT</i>	s16	T1_OUT_L[7:0]								R
0x3F			T1_OUT_H[7:0]								R

- u8: unsigned 8-bit
- s16: signed 16-bit using 2's complement
- 10-bit T0 Temperature calibration value: 8-bit T_degC_0[7:0] from the register (0x32) and 2 bit T_0[1:0] from the register (0x35)
- 10-bit T1 Temperature calibration value: 8-bit T_degC_1[7:0] from the register (0x33) and 2 bit T_1[1:0] from the register (0x35)

¹ The registers contents are loaded at boot procedure should not be changed. They contain the factory calibration values and their content is automatically restored when the device is powered up.



Writing to Reserved marked in the registers is not allowed. Writing to those reserved marked bits may cause permanent damage to the sensor.



The content of the calibration registers should not be changed.

11 Register description

11.1 Device_ID (0x0F)

The value of this register gives the device ID: 0xBC (b10111100)

Bit 7	Bit 6	Bit 5	Bit 4	Bit 3	Bit 2	Bit 1	Bit 0	Type
1	0	1	1	1	1	0	0	R

Table 12: *Device_ID* register

11.2 Average (0x10)

Bit 7	Bit 6	Bit 5	Bit 4	Bit 3	Bit 2	Bit 1	Bit 0	Type
Reserved		AVG_T[2:0]			AVG_H[2:0]			R/W

Table 13: *Average* register

bits	Description
AVG_T[2:0]	Internal averaging of the samples for temperature output values
AVG_H[2:0]	Internal averaging of the samples for humidity output values

Table 14: *Average* register description

AVG_T[2:0] / AVG_H[2:0]	Number of samples averaged (Temperature)	Number of samples averaged (Humidity)	Noise (°C)	Noise (rh %)
000	2	4	0.08	1.14
001	4	8	0.05	0.54
010	8	16	0.04	0.37
011 ¹	16	32	0.03	0.35
100	32	64	0.02	0.11
101	64	128	0.015	0.009
110	128	256	0.01	0.05
111	256	512	0.007	0.03

Table 15: Number of internal averaging samples

1. Default configuration

11.3 CTRL_1 (0x20)

Bit 7	Bit 6	Bit 5	Bit 4	Bit 3	Bit 2	Bit 1	Bit 0	Type
PD	Reserved				BDU	ODR[1:0]		R/W

Table 16: CTRL_1 register

bits	Description
PD	Power down. By default, PD: 0 which is power down mode. PD: 1 Continuous mode for active measurement
BDU	Block data update. 0: Continuous update, 1: Output registers are not updated until MSB and LSB is read
ODR[1:0]	Output data rate of the humidity and temperature value

Table 17: CTRL_1 register description

11.3.1 Block data update (BDU)

It is strongly recommended to set the BDU bit to '1' in the CTRL_1 register. By default the BDU bit is '0' and the output registers are continuously updated. When the BDU bit is set to '1' the content of the output registers is not updated until both MSB and LSB are read. It avoids reading values related to different samples. As soon as the BDU is activated, the output registers always contain the most recent output data produced by the sensor. If the processor initiate the read function of the output registers T_OUT_L, T_OUT_H, H_OUT_L and H_OUT_H, the update for that pair is blocked until both MSB and LSB of the data is read.

ODR[1:0]	Output data rate
00	One shot mode
01	1 Hz
10	7 Hz
11	12.5 Hz

Table 18: Output data rate

11.4 CTRL_2 (0x21)

Bit 7	Bit 6	Bit 5	Bit 4	Bit 3	Bit 2	Bit 1	Bit 0	Type
BOOT	Reserved					Heater	ONE SHOT	R/W

Table 19: CTRL_2 register

bits	Description
BOOT	Reboot memory content. 0: normal mode, 1: reboot memory content
Heater	Heater enable/disable. By default 0: disable, 1: enable
ONE SHOT	One shot mode enable. By default 0: conversion done, 1: start of new conversion

Table 20: CTRL_2 register description

11.4.1 BOOT

The content of the internal registers stored in the flash memory block can be refreshed using BOOT bit. After proper powering of the sensor, content of the flash memory is loaded to the internal registers. When the BOOT bit is set to '1' the content of the internal flash memory block is copied to the internal registers and also calibrates the sensor. Each sensor has different factory trimmed values stored in the internal flash memory. The content in the flash memory copied to internal registers permit good performance of the sensor. Therefore the content of the internal registers should not be modified.

11.4.2 Heater

In case of condensation on the sensor, heater can be turned on using Heater bit. The heating of the sensor element will speed up the recovery time of the sensor after condensation. During active heating, the humidity and temperature output values should not be read. It is also recommended that output values should not be read immediately after turning off the heater.

Supply voltage (V)	Current consumption (mA)
3.3	33

Table 21: Current consumption of the heater

11.5 CTRL_3 (0x22)

Bit 7	Bit 6	Bit 5	Bit 4	Bit 3	Bit 2	Bit 1	Bit 0	Type
DRDY_H_L	PP_OD	Reserved			DRDY_EN	Reserved		R/W

Table 22: CTRL_3 register

bits	Description
DRDY_H_L	DRDY output signal on INT pin: Active high/low. Default value: 0 (0: active high, 1: active low)
PP_OD	Push pull or open drain selection on INT pin. Default value: 0 (0: Push-pull, 1: open drain)
DRDY_EN	Data ready interrupt enable on INT pin. Default value: 0 (0: disabled, 1: enabled)

Table 23: CTRL_3 register description

11.6 STATUS (0x27)

Bit 7	Bit 6	Bit 5	Bit 4	Bit 3	Bit 2	Bit 1	Bit 0	Type
Reserved						H_DA	T_DA	R

Table 24: STATUS register

bits	Description
H_DA	Humidity data available (0: no humidity data is available in the output registers, 1: new humidity data is available in the output registers). As soon as the H_OUT_H register is read, the H_DA bit is set to '0'
T_DA	Temperature data available (0: no temperature data is available in the output registers, 1: new temperature data is available in the output register). As soon as the T_OUT_H is read, the T_DA bit is set to '0'

Table 25: STATUS register description

11.7 H_OUT_L (0x28)

The value of the humidity output registers $H_OUT_L(0x28)$ and $H_OUT_H(0x29)$ is expressed in 16-bit resolution. Please refer chapter 9.1 to obtain the humidity value from 16-bit values of the output registers.

Bit 7	Bit 6	Bit 5	Bit 4	Bit 3	Bit 2	Bit 1	Bit 0	Type
HUMIDITY[7:0]								R

Table 26: H_OUT_L register

bits	Description
HUMIDITY[7:0]	8 least significant bits (LSB) of the humidity sensor output

Table 27: H_OUT_L register description

11.8 H_OUT_H (0x29)

Bit 7	Bit 6	Bit 5	Bit 4	Bit 3	Bit 2	Bit 1	Bit 0	Type
HUMIDITY[7:0]								R

Table 28: H_OUT_H register

bits	Description
HUMIDITY[7:0]	8 most significant bits (MSB) of the humidity sensor output

Table 29: H_OUT_H register description

The software drivers must clip output values exceeding the measurement range of the humidity sensor.

11.9 T_OUT_L (0x2A)

The value of the temperature output registers $T_OUT_L(0x2A)$ and $T_OUT_H(0x0E)$ is expressed in 16-bit resolution. Please refer chapter 9.3 to obtain the temperature value from 16-bit values of the output registers.

Bit 7	Bit 6	Bit 5	Bit 4	Bit 3	Bit 2	Bit 1	Bit 0	Type
TEMP[7:0]								R

Table 30: T_OUT_L register

bits	Description
TEMP[7:0]	8 least significant bits (LSB) of the temperature sensor output

Table 31: *T_OUT_L* register description

11.10 T_OUT_H (0x2B)

Bit 7	Bit 6	Bit 5	Bit 4	Bit 3	Bit 2	Bit 1	Bit 0	Type
TEMP[7:0]								R

Table 32: *T_OUT_H* register

bits	Description
TEMP[7:0]	8 most significant bits (MSB) of the temperature sensor output

Table 33: *T_OUT_H* register description

12 Handling humidity sensor

- It is important to understand that a humidity sensor is not a normal electronic component and needs to be handled with care.
- Chemical vapours at high concentration in combination with long exposure time may offset the sensor reading.
- Furthermore it is recommended to store the sensors with temperature range of 10 °C and 40 °C and humidity with a range of 20 rH% and 60 rH%.
- Long-term exposure to conditions outside normal humidity and temperature range, especially at higher humidity range, may temporarily offset the output signal of humidity sensor.
- After returning to the normal exposure conditions, the humidity output value will slowly return to the calibration state by itself.
- If such cases happen, to recover the sensor accuracy to the normal state, it has to be reconditioned to the following procedure :
 1. Baking: 100 °C to 110 °C at 5 rH% for 12h
 2. Re-hydration: 20 °C to 30 °C at 75 rH% for 12h

13 Physical dimensions

13.1 Module drawing

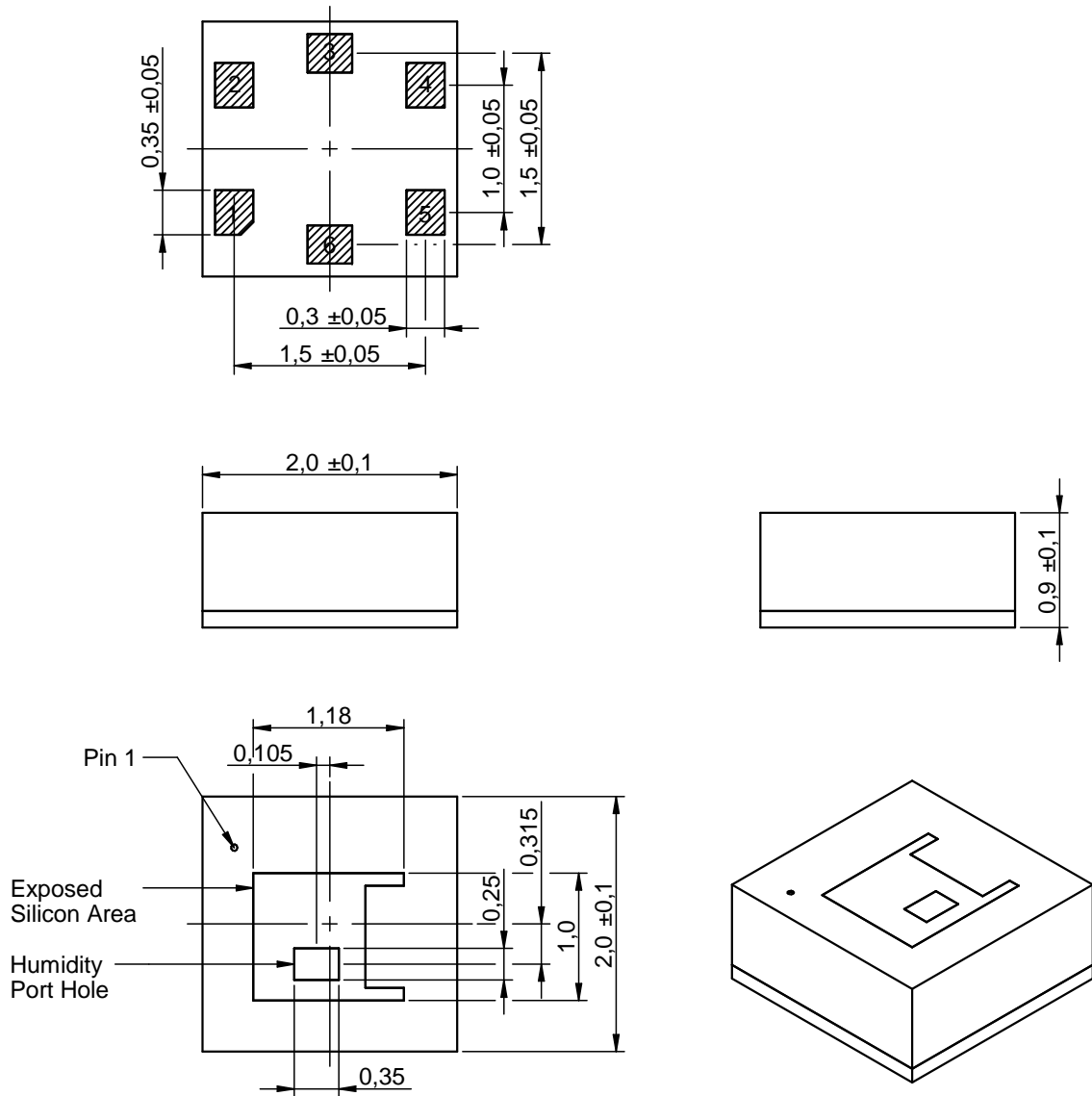

Figure 17: Sensor dimension [mm]

13.2 Footprint

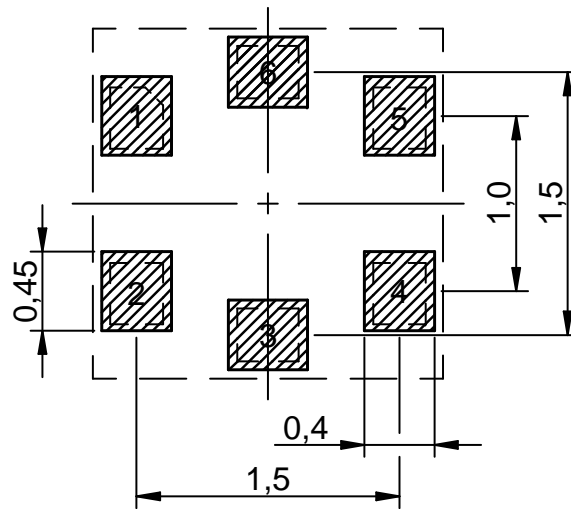

Figure 18: Recommended land pattern [mm] (top view)

14 Manufacturing information

14.1 Moisture sensitivity level

The sensor product is categorized as JEDEC Moisture Sensitivity Level 3 (MSL3), which requires special handling.

More information regarding the MSL requirements can be found in the IPC/JEDEC J-STD-020 standard on www.jedec.org. More information about the handling, picking, shipping and the usage of moisture/re-flow and/or process sensitive products can be found in the IPC/JEDEC J-STD-033 standard on www.jedec.org.

14.2 Soldering

14.2.1 Reflow soldering

Attention must be paid on the thickness of the solder resist between the host PCB top side and the modules bottom side. Only lead-free assembly is recommended according to JEDEC J-STD020.

Profile feature		Value
Preheat temperature Min	$T_{S \text{ Min}}$	150 °C
Preheat temperature Max	$T_{S \text{ Max}}$	200 °C
Preheat time from $T_{S \text{ Min}}$ to $T_{S \text{ Max}}$	t_s	60 - 120 seconds
Ramp-up rate (T_L to T_P)		3 °C / second max.
Liquidous temperature	T_L	217 °C
Time t_L maintained above T_L	t_L	60 - 150 seconds
Peak package body temperature	T_P	see table below
Time within 5 °C of actual peak temperature	t_p	20 - 30 seconds
Ramp-down Rate (T_P to T_L)*		6 °C / second max.
Time 20 °C to T_P		8 minutes max.

Table 34: Classification reflow soldering profile, Note: refer to IPC/JEDEC J-STD-020E

*** In order to reduce residual stress on the sensor component, the recommended ramp-down temperature slope should be lower than 3 °C /s.**

Package thickness	Volume mm ³ <350	Volume mm ³ 350-2000	Volume mm ³ >2000
< 1.6mm	260 °C	260 °C	260 °C
1.6mm - 2.5mm	260 °C	250 °C	245 °C
> 2.5mm	250 °C	245 °C	245 °C

Table 35: Package classification reflow temperature, PB-free assembly, Note: refer to IPC/-JEDEC J-STD-020E

It is recommended to solder the sensor on the last re-flow cycle of the PCB. For solder paste use a LFM-48W or Indium based SAC 305 alloy (Sn 96.5 / Ag 3.0 / Cu 0.5 / Indium 8.9HF / Type 3 / 89%) type 3 or higher.

The reflow profile must be adjusted based on the thermal mass of the entire populated PCB, heat transfer efficiency of the re-flow oven and the specific type of solder paste used. Based on the specific process and PCB layout the optimal soldering profile must be adjusted and verified. Other soldering methods (e.g. vapor phase) have not been verified and have to be validated by the customer at their own risk. Rework is not recommended.

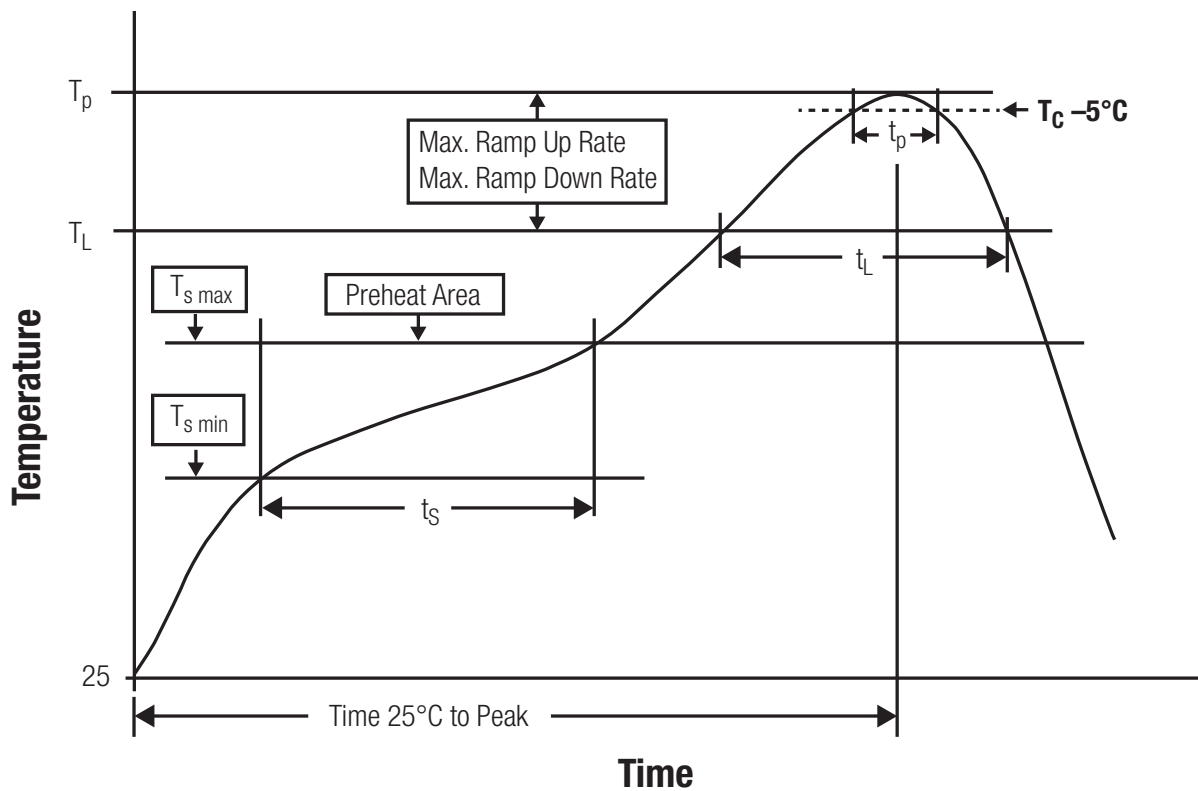

Figure 19: Reflow soldering profile

After reflow soldering, visually inspect the board to confirm proper alignment

14.2.2 Cleaning and washing

Do not clean the product. Any residue cannot be easily removed by washing. Use a "no clean" soldering paste and do not clean the board after soldering.

- Washing agents used during the production to clean the customer application might damage or change the characteristics of the component. Washing agents may have a negative effect on the long-term functionality of the product.
- Using a brush during the cleaning process may damage the component. Therefore, we do not recommend using a brush during the PCB cleaning process

14.2.3 Potting and coating

- Potting material might shrink or expand during and after hardening. This might apply mechanical stress on the components, which can influence the characteristics of the transfer function. In addition, potting material can close existing openings in the housing. This can lead to a malfunction of the component. Thus, potting is not recommended.
- Conformal coating may affect the product performance. We do not recommend coating the components.

14.2.4 Storage conditions

- A storage of Würth Elektronik eiSos products for longer than 12 months is not recommended. Within other effects, the terminals may suffer degradation, resulting in bad solderability. Therefore, all products shall be used within the period of 12 months based on the day of shipment.
- Do not expose the components to direct sunlight.
- The storage conditions in the original packaging are defined according to DIN EN 61760 - 2.
- For a moisture sensitive component, the storage condition in the original packaging is defined according to IPC/JEDEC-J-STD-033. It is also recommended to return the component to the original moisture proof bag and reseal the moisture proof bag again.

14.2.5 Handling

- Violation of the technical product specifications such as exceeding the nominal rated supply voltage, will void the warranty.
- Violation of the technical product specifications such as but not limited to exceeding the absolute maximum ratings will void the conformance to regulatory requirements.
- ESD prevention methods need to be followed for manual handling and processing by machinery.
- The edge castellation is designed and made for prototyping, i.e. hand soldering purposes only.

- The applicable country regulations and specific environmental regulations must be observed.
- Do not disassemble the product. Evidence of tampering will void the warranty.

15 Important notes

The following conditions apply to all goods within the sensors product range of Würth Elektronik eiSos GmbH & Co. KG:

15.1 General customer responsibility

Some goods within the product range of Würth Elektronik eiSos GmbH & Co. KG contain statements regarding general suitability for certain application areas. These statements about suitability are based on our knowledge and experience of typical requirements concerning the areas, serve as general guidance and cannot be estimated as binding statements about the suitability for a customer application. The responsibility for the applicability and use in a particular customer design is always solely within the authority of the customer. Due to this fact, it is up to the customer to evaluate, where appropriate to investigate and to decide whether the device with the specific product characteristics described in the product specification is valid and suitable for the respective customer application or not. Accordingly, the customer is cautioned to verify that the documentation is current before placing orders.

15.2 Customer responsibility related to specific, in particular safety-relevant applications

It has to be clearly pointed out that the possibility of a malfunction of electronic components or failure before the end of the usual lifetime cannot be completely eliminated in the current state of the art, even if the products are operated within the range of the specifications. The same statement is valid for all software and software parts contained in or used with or for products in the sensor product range of Würth Elektronik eiSos GmbH & Co. KG. In certain customer applications requiring a high level of safety and especially in customer applications in which the malfunction or failure of an electronic component could endanger human life or health, it must be ensured by most advanced technological aid of suitable design of the customer application that no injury or damage is caused to third parties in the event of malfunction or failure of an electronic component.

15.3 Best care and attention

Any product-specific data sheets, manuals, application notes, PCN's, warnings and cautions must be strictly observed in the most recent versions and matching to the products revisions. This documents can be downloaded from the product specific sections on the wireless connectivity and sensors homepage.

15.4 Customer support for product specifications

Some products within the product range may contain substances, which are subject to restrictions in certain jurisdictions in order to serve specific technical requirements. Necessary information is available on request. In this case, the field sales engineer or the internal sales person in charge should be contacted who will be happy to support in this matter.

15.5 Product improvements

Due to constant product improvement, product specifications may change from time to time. As a standard reporting procedure of the Product Change Notification (PCN) according to the JEDEC-Standard, we inform about major changes. In case of further queries regarding the PCN, the field sales engineer, the internal sales person or the technical support team in charge should be contacted. The basic responsibility of the customer as per section 15.1 and 15.2 remains unaffected.

The sensor driver software "Sensor SDK" and its source codes are not subject to the Product Change Notification information process.

15.6 Product life cycle

Due to technical progress and economical evaluation we also reserve the right to discontinue production and delivery of products. As a standard reporting procedure of the Product Termination Notification (PTN) according to the JEDEC-Standard we will inform at an early stage about inevitable product discontinuance. According to this, we cannot ensure that all products within our product range will always be available. Therefore, it needs to be verified with the field sales engineer or the internal sales person in charge about the current product availability expectancy before or when the product for application design-in disposal is considered. The approach named above does not apply in the case of individual agreements deviating from the foregoing for customer-specific products.

15.7 Property rights

All the rights for contractual products produced by Würth Elektronik eiSos GmbH & Co. KG on the basis of ideas, development contracts as well as models or templates that are subject to copyright, patent or commercial protection supplied to the customer will remain with Würth Elektronik eiSos GmbH & Co. KG. Würth Elektronik eiSos GmbH & Co. KG does not warrant or represent that any license, either expressed or implied, is granted under any patent right, copyright, mask work right, or other intellectual property right relating to any combination, application, or process in which Würth Elektronik eiSos GmbH & Co. KG components or services are used.

15.8 General terms and conditions

Unless otherwise agreed in individual contracts, all orders are subject to the current version of the "General Terms and Conditions of Würth Elektronik eiSos Group", last version available at www.we-online.com.

16 Legal notice

16.1 Exclusion of liability

Würth Elektronik eiSos GmbH & Co. KG considers the information in this document to be correct at the time of publication. However, Würth Elektronik eiSos GmbH & Co. KG reserves the right to modify the information such as technical specifications or functions of its products or discontinue the production of these products or the support of one of these products without any written announcement or notification to customers. The customer must make sure that the information used corresponds to the latest published information. Würth Elektronik eiSos GmbH & Co. KG does not assume any liability for the use of its products. Würth Elektronik eiSos GmbH & Co. KG does not grant licenses for its patent rights or for any other of its intellectual property rights or third-party rights.

Notwithstanding anything above, Würth Elektronik eiSos GmbH & Co. KG makes no representations and/or warranties of any kind for the provided information related to their accuracy, correctness, completeness, usage of the products and/or usability for customer applications. Information published by Würth Elektronik eiSos GmbH & Co. KG regarding third-party products or services does not constitute a license to use such products or services or a warranty or endorsement thereof.

16.2 Suitability in customer applications

The customer bears the responsibility for compliance of systems or units, in which Würth Elektronik eiSos GmbH & Co. KG products are integrated, with applicable legal regulations. Customer acknowledges and agrees that it is solely responsible for compliance with all legal, regulatory and safety-related requirements concerning its products, and any use of Würth Elektronik eiSos GmbH & Co. KG components in its applications, notwithstanding any applications-related information or support that may be provided by Würth Elektronik eiSos GmbH & Co. KG. Customer represents and agrees that it has all the necessary expertise to create and implement safeguards which anticipate dangerous consequences of failures, monitor failures and their consequences lessen the likelihood of failures that might cause harm and take appropriate remedial actions. The customer will fully indemnify Würth Elektronik eiSos GmbH & Co. KG and its representatives against any damages arising out of the use of any Würth Elektronik eiSos GmbH & Co. KG components in safety-critical applications.

16.3 Usage restriction

Würth Elektronik eiSos GmbH & Co. KG products have been designed and developed for usage in general electronic equipment only. This product is not authorized for use in equipment where a higher safety standard and reliability standard is especially required or where a failure of the product is reasonably expected to cause severe personal injury or death, unless the parties have executed an agreement specifically governing such use. Moreover, Würth Elektronik eiSos GmbH & Co. KG products are neither designed nor intended for use in areas such as military, aerospace, aviation, nuclear control, submarine, transportation (automotive control, train control, ship control), transportation signal, disaster prevention, medical, public information network etc. Würth Elektronik eiSos GmbH & Co. KG must be

informed about the intent of such usage before the design-in stage. In addition, sufficient reliability evaluation checks for safety must be performed on every electronic component, which is used in electrical circuits that require high safety and reliability function or performance. By using Würth Elektronik eiSos GmbH & Co. KG products, the customer agrees to these terms and conditions.

17 License terms for Würth Elektronik eiSos GmbH & Co. KG sensor product software and source code

This License terms will take effect upon the purchase and usage of the Würth Elektronik eiSos GmbH & Co. KG sensor products. You hereby agree that this license terms are applicable to the product and the incorporated software, firmware and source codes (collectively, "Software") made available by Würth Elektronik eiSos in any form, including but not limited to binary, executable or source code form.

The software included in any Würth Elektronik eiSos sensor product is purchased to you on the condition that you accept the terms and conditions of this license terms. You agree to comply with all provisions under this license terms.

17.1 Limited license

Würth Elektronik eiSos hereby grants you a limited, non-exclusive, non-transferable and royalty-free license to use the software and under the conditions that will be set forth in this license terms. You are free to use the provided software only in connection with one of the products from Würth Elektronik eiSos to the extent described in this license terms.

You are entitled to change or alter the source code for the sole purpose of creating an application embedding the Würth Elektronik eiSos sensor product. The transfer of the source code to third parties is allowed to the sole extent that the source code is used by such third parties in connection with our product or another hardware provided by Würth Elektronik eiSos under strict adherence of this license terms. Würth Elektronik eiSos will not assume any liability for the usage of the incorporated software and the source code.

You are not entitled to transfer the source code in any form to third parties without prior written consent of Würth Elektronik eiSos.

You are not allowed to reproduce, translate, reverse engineer, decompile, disassemble or create derivative works of the incorporated software and the source code in whole or in part. No more extensive rights to use and exploit the products are granted to you.

17.2 Usage and obligations

The responsibility for the applicability and use of the Würth Elektronik eiSos sensor product with the incorporated software in a particular customer design is always solely within the authority of the customer. Due to this fact, it is up to you to evaluate and investigate, where appropriate, and to decide whether the device with the specific product characteristics described in the product specification is valid and suitable for your respective application or not.

You are responsible for using the Würth Elektronik eiSos sensor product with the incorporated software in compliance with all applicable product liability and product safety laws. You acknowledge to minimize the risk of loss and harm to individuals and bear the risk for failure leading to personal injury or death due to your usage of the product.

Würth Elektronik eiSos' products are not authorized for use in safety-critical applications, or where a failure of the product is reasonably expected to cause severe personal injury or death. Moreover, Würth Elektronik eiSos' products are neither designed nor intended for

use in areas such as military, aerospace, aviation, nuclear control, submarine, transportation (automotive control, train control, ship control), transportation signal, disaster prevention, medical, public information network etc. You shall inform Würth Elektronik eiSos about the intent of such usage before design-in stage. In certain customer applications requiring a very high level of safety and in which the malfunction or failure of an electronic component could endanger human life or health, you must ensure to have all necessary expertise in the safety and regulatory ramifications of your applications. You acknowledge and agree that you are solely responsible for all legal, regulatory and safety-related requirements concerning your products and any use of Würth Elektronik eiSos' products in such safety-critical applications, notwithstanding any applications-related information or support that may be provided by Würth Elektronik eiSos. YOU SHALL INDEMNIFY WÜRTH ELEKTRONIK EISOS AGAINST ANY DAMAGES ARISING OUT OF THE USE OF WÜRTH ELEKTRONIK EISOS' PRODUCTS IN SUCH SAFETY-CRITICAL APPLICATIONS.

17.3 Ownership

The incorporated Software created by Würth Elektronik eiSos is and will remain the exclusive property of Würth Elektronik eiSos.

17.4 Disclaimer of warranty

THE SOFTWARE AND IT'S SOURCE CODE IS PROVIDED "AS IS". YOU ACKNOWLEDGE THAT WÜRTH ELEKTRONIK EISOS MAKES NO REPRESENTATIONS AND WARRANTIES OF ANY KIND RELATED TO, BUT NOT LIMITED TO THE NON-INFRINGEMENT OF THIRD PARTIES' INTELLECTUAL PROPERTY RIGHTS OR THE MERCHANTABILITY OR FITNESS FOR YOUR INTENDED PURPOSE OR USAGE. WÜRTH ELEKTRONIK EISOS DOES NOT WARRANT OR REPRESENT THAT ANY LICENSE, EITHER EXPRESS OR IMPLIED, IS GRANTED UNDER ANY PATENT RIGHT, COPYRIGHT, MASK WORK RIGHT, OR OTHER INTELLECTUAL PROPERTY RIGHT RELATING TO ANY COMBINATION, MACHINE, OR PROCESS IN WHICH THE WÜRTH ELEKTRONIK EISOS' PRODUCT WITH THE INCORPORATED SOFTWARE IS USED. INFORMATION PUBLISHED BY WÜRTH ELEKTRONIK EISOS REGARDING THIRD-PARTY PRODUCTS OR SERVICES DOES NOT CONSTITUTE A LICENSE FROM WÜRTH ELEKTRONIK EISOS TO USE SUCH PRODUCTS OR SERVICES OR A WARRANTY OR ENDORSEMENT THEREOF.

17.5 Limitation of liability

Any liability not expressly provided by Würth Elektronik eiSos shall be disclaimed. You agree to hold us harmless from any third-party claims related to your usage of the Würth Elektronik eiSos' products with the incorporated software and source code. Würth Elektronik eiSos disclaims any liability for any alteration, development created by you or your customers as well as for any combination with other products.

17.6 Applicable law and jurisdiction

Applicable law to this license terms shall be the laws of the Federal Republic of Germany. Any dispute, claim or controversy arising out of or relating to this license terms shall be

resolved and finally settled by the court competent for the location of Würth Elektronik eiSos registered office.

17.7 Severability clause

If a provision of this license terms are or becomes invalid, unenforceable or null and void, this shall not affect the remaining provisions of the terms. The parties shall replace any such provisions with new valid provisions that most closely approximate the purpose of the terms.

17.8 Miscellaneous

Würth Elektronik eiSos reserves the right at any time to change this terms at its own discretion. It is your responsibility to check at Würth Elektronik eiSos homepage for any updates. Your continued usage of the products will be deemed as the acceptance of the change.

We recommend you to be updated about the status of new software, which is available on our website or in our data sheet, and to implement new software in your device where appropriate.

By ordering a sensor product, you accept this license terms in all terms.

List of Figures

1	Block diagram	7
2	Pinout (top view)	11
3	Electrical connection (top view)	12
4	Master-slave concept	13
5	Data validity, START and STOP condition	14
6	Slave address format	15
7	Complete data transfer	16
8	Write and read operations of the sensor	16
9	SPI Interface	19
10	SPI register address	21
11	4-wire SPI data transfer (CPOL = 1, CPHA = 1)	21
12	SPI write protocol	22
13	SPI read protocol	22
14	Communication check	24
15	Sensor in operation	25
16	Operating modes	26
17	Sensor dimension [mm]	40
18	Recommended land pattern [mm] (top view)	41
19	Reflow soldering profile	43

List of Tables

1	Ordering information	7
2	Humidity sensor specification	8
3	Temperature sensor specification	8
4	Electrical specification	9
5	Absolute maximum rating	9
6	General information	10
7	Pin description	11
8	I ² C timing parameters	18
9	SPI communication modes	20
10	SPI timing parameters	23
11	Output data rate	27
12	<i>Device_ID</i> register	33
13	<i>Average</i> register	33
14	<i>Average</i> register description	33
15	Number of internal averaging samples	34
16	<i>CTRL_1</i> register	34
17	<i>CTRL_1</i> register description	34
18	Output data rate	35
19	<i>CTRL_2</i> register	35
20	<i>CTRL_2</i> register description	35
21	Current consumption of the heater	36
22	<i>CTRL_3</i> register	36
23	<i>CTRL_3</i> register description	36
24	<i>STATUS</i> register	36

25	STATUS register description	36
26	H_OUT_L register	37
27	H_OUT_L register description	37
28	H_OUT_H register	37
29	H_OUT_H register description	37
30	T_OUT_L register	37
31	T_OUT_L register description	38
32	T_OUT_H register	38
33	T_OUT_H register description	38
34	Classification reflow soldering profile, Note: refer to IPC/JEDEC J-STD-020E	42
35	Package classification reflow temperature, PB-free assembly, Note: refer to IPC/JEDEC J-STD-020E	43



more than you expect



**Internet
of Things**



**Monitoring
& Control**



**Automated Meter
Reading**

Contact:

Würth Elektronik eiSos GmbH & Co. KG
Division Wireless Connectivity & Sensors

Max-Eyth-Straße 1
74638 Waldenburg
Germany

Tel.: +49 651 99355-0

Fax.: +49 651 99355-69

www.we-online.com/wireless-connectivity

