

Full Color
Night Vision

imou
Enjoy Smart Life

EN

DE

ES

FR

IT

NL

PT

Quick Start Guide

Bullet 2 4MP

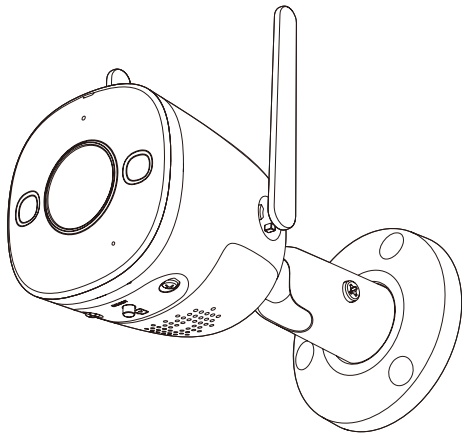

www.imoulife.com

Welcome

Thank you for choosing IMOUI.

We are devoted to providing you easy smart home products.

If you have problems using the product, please contact our service team before returning your product.

Our service mail: service.global@imoulife.com

Frequently asked questions can be found at imoulife.com/support/help



Package content

EN

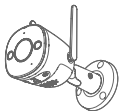

Camera x1



Positioning Map x1

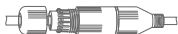

Waterproof Connector x1



Screw Package x1



Quick Start Guide x1

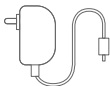

Power Adapter x1

Camera introduction

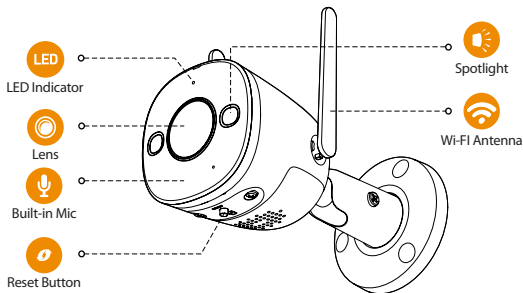

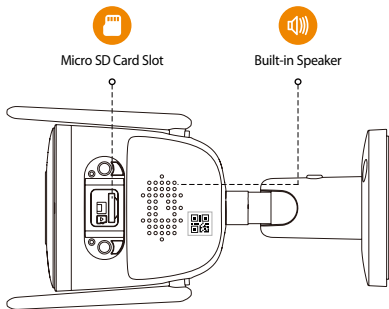

The pattern of the LED indicator is included in the following table.

LED Status	Device Status
Off	<ul style="list-style-type: none"> ● Powered off/LED turned off ● Rebooting after reset
Red light on	<ul style="list-style-type: none"> ● Booting ● Device malfunction
Green light flashing	<ul style="list-style-type: none"> ● Waiting for network
Green light on	<ul style="list-style-type: none"> ● Operating properly
Red light flashing	<ul style="list-style-type: none"> ● Network connection failed
Green and red light flashing alternately	<ul style="list-style-type: none"> ● Firmware updating

1

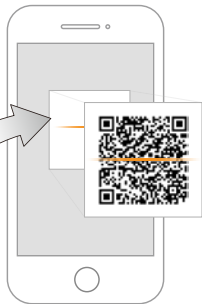

Imou Life



i Tips

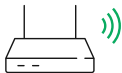
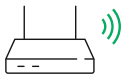

To ensure the best possible wireless performance, please make sure there are no obstacles and electromagnetic interference between the camera and router.

2

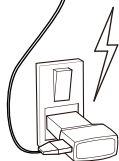
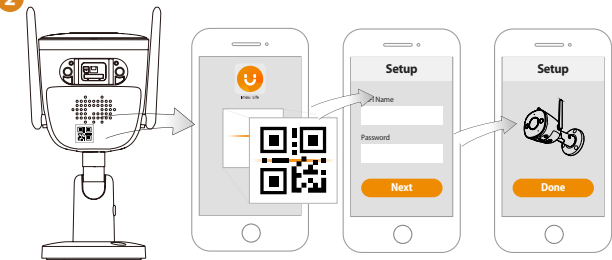

3 Installing the Camera

Mounting Screw ②

Camera ③

Wall Anchor ①

Positioning Map ○

Mounting Surface ○

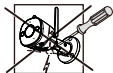
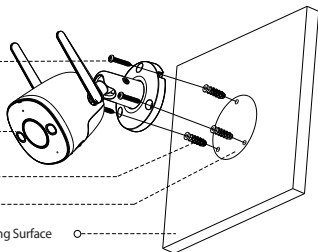

DC
12V1A

Problem	Solution
Cannot set up camera	<ul style="list-style-type: none"> • Ensure your mobile device and the camera are within range of your Wi-Fi router. • Ensure the LED indicator on the camera is flashing green before beginning setup.
The APP says "Failed to configure device network"	<ul style="list-style-type: none"> • Reset your Camera and connect it again. • Some cameras only support 2.4GHz, while some routers have dual band, 2.4G/5G. Make sure you are connecting 2.4GHz only.
The app says "Failed to bind"	<p>The camera is already connected to Wi-Fi, but the router is:</p> <ul style="list-style-type: none"> • Not connected to Internet • Poor network status • The Wi-Fi signal is not stable due to obstacles or electronic interference
No picture / signal	<ul style="list-style-type: none"> • Ensure the LED indicator on the camera is flashing steady green. See 'LED Status' section for details if otherwise. • Ensure the camera is properly connected to power using the included USB power adapter. • Try repositioning the camera, router, or both to improve signal strength.
Picture is not clear	<ul style="list-style-type: none"> • Check the camera lens for dirt, dust, spider webs. Clean the lens with a soft, clean cloth. • Remove the vinyl cover on the camera lens.
No audio	<ul style="list-style-type: none"> • Ensure audio function on camera is turned on. • Ensure audio is turned up on viewing device.
Human detection not working	<ul style="list-style-type: none"> • Ensure you have enabled "Human Detection" in the Device Settings screen of the Imou LifeApp.
Phone is not reading QR code	<ul style="list-style-type: none"> • Clean the camera lens of your Smartphone • Ensure that there is enough light on the QR code • Don't hold the QR code too close to the camera

Kurzanleitung

Bullet 2 4MP

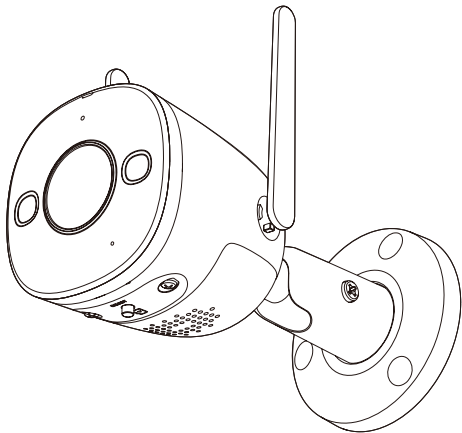

Willkommen

Vielen Dank, dass Sie sich für IMOU entschieden haben. Wir sind bestrebt, einfachere Produkte für das intelligente Heim anzubieten. Wenn Sie Probleme bei der Verwendung des Produkts haben, wenden Sie sich bitte an unser Serviceteam.

Unsere Service-Mail lautet: service.global@imoulife.com

Häufig gestellte Fragen finden Sie unter imoulife.com/support/help



Packungsinhalt

DE

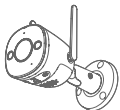

Kamera x 1



Montageschablone x 1

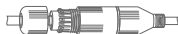

Wasserdichter Anschluss x 1



Schraubenbeutel x 1



Kurzanleitung x 1

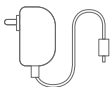

Netzteil x 1

Einführung in die Kamera

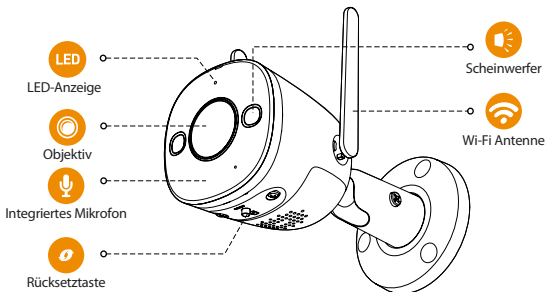

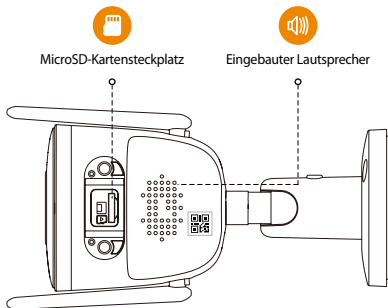

Das Muster der LED-Anzeigen ist in der folgenden Tabelle aufgeführt.

LED-Status/Gerätstatus	Device Status
AUS	<ul style="list-style-type: none"> ● Abgeschaltet/LED Ausgeschaltet ● Gerät fährt nach Rücksetzung hoch
Rote LED leuchtet	<ul style="list-style-type: none"> ● Gerät fährt hoch ● Gerätestörung
Grüne LED blinkt	<ul style="list-style-type: none"> ● Warten auf
Grüne LED leuchtet	<ul style="list-style-type: none"> ● Ordnungsgemäßer Betrieb
Rechte LED blinkt	<ul style="list-style-type: none"> ● Netzwerkverbindung fehlgeschlagen
Grüne und rote LED blinken abwechselnd	<ul style="list-style-type: none"> ● Firmware-Update

1

DE

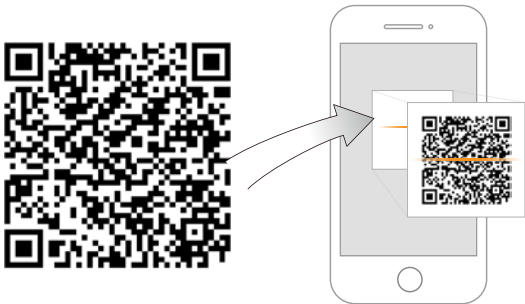

Imou Life



Tips

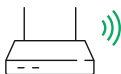

Um die bestmögliche Funkübertragung zu gewährleisten, stellen Sie sicher, dass zwischen Kamera und Router keine Hindernisse und elektromagnetische Störungen vorhanden sind.

2



DE

3 Kamerainstallieren

Selbstschneidende
Schraube ②

Kamera ③

Dübel ①

Montageschablone ○

Montagefläche ○

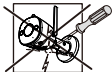
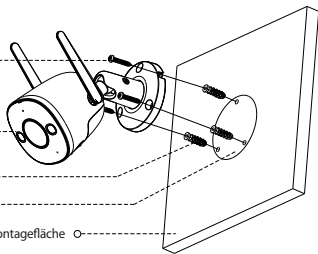

DC
12V1A

Problem	Lösungen
Kamera kann nicht eingerichtet werden	<ul style="list-style-type: none"> • Stellen Sie sicher, dass Ihr mobiles Gerät und die Kamera in Reichweite Ihres WLAN-Routers sind. • Vergewissern Sie sich, dass die LED-Anzeige an der Kamera grün blinkt, bevor Sie mit der Einrichtung beginnen.
Die App meldet: „Konfiguration des Gerätnetzes fehlgeschlagen“	<ul style="list-style-type: none"> • Setzen Sie Ihre Kamera zurück und schließen Sie sie wieder an. • Einige Kameras unterstützen nur 2,4 GHz, während einige Router über Dualband mit 2,4 GHz/5 GHz verfügen. Stellen Sie sicher, dass Sie sie nur mit 2,4 GHz verbinden.
Die App meldet: „Verbindung fehlgeschlagen“	<p>Die Kamera ist bereits mit WLAN verbunden, aber der Router:</p> <ul style="list-style-type: none"> • ist nicht mit dem Internet verbunden • hat einen mangelhaften Netzwerkzustand • Das WLAN-Signal ist aufgrund von Hindernissen oder elektronischen Störungen nicht stabil
Kein Bild/Signal	<ul style="list-style-type: none"> • Stellen Sie sicher, dass die LED-Anzeige an der Kamera stetig grün blinkt. Siehe Abschnitt „LED-Status“ für Einzelheiten, wenn dies nicht der Fall ist. • Stellen Sie sicher, dass die Kamera mit dem mitgelieferten USB-Netzteil ordnungsgemäß an die Stromversorgung angeschlossen ist. • Versuchen Sie, die Kamera, den Router oder beides neu zu positionieren, um die Signalstärke zu verbessern.
Das Bild ist nicht klar	<ul style="list-style-type: none"> • Überprüfen Sie das Kameraobjektiv auf Schmutz, Staub und Spinnennetze. Reinigen Sie das Objektiv mit einem weichen, sauberen Tuch. • Entfernen Sie die Kunststoff-Abdeckung des Kameraobjektivs.
Kein Ton	<ul style="list-style-type: none"> • Stellen Sie sicher, dass der Kameraton eingeschaltet ist. • Stellen Sie sicher, dass der Ton am Anzeigegerät eingeschaltet ist.
Personenerkennung funktioniert nicht	<ul style="list-style-type: none"> • Vergewissern Sie sich, dass Sie „Personenerkennung“ in den Geräteeinstellungen der Imou Life-App aktiviert haben.
Telefon liest keinen QR-Code	<ul style="list-style-type: none"> • Reinigen Sie die Kameralinse Ihres Smartphones • Stellen Sie sicher, dass der QR-Code ausreichend beleuchtet ist • Halten Sie den QR-Code nicht zu nah an die Kamera

Guía de inicio rápido

Bullet 2 4MP

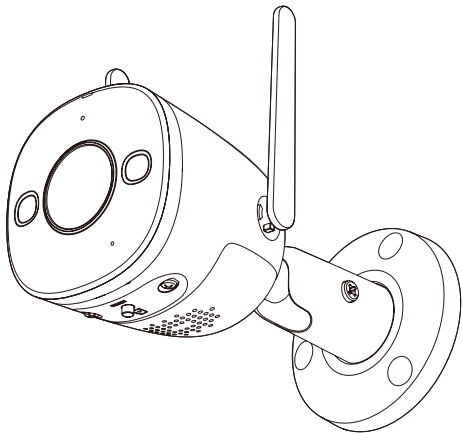

Bienvenido

ES

Gracias por elegir IMOU

Nuestra misión es proporcionar productos fáciles de usar para un hogar inteligente. Si tiene problemas usando el producto, por favor diríjase a nuestro equipo de atención al cliente antes de devolver su producto.

Nuestro correo electrónico de servicio:

service.global@imoulife.com

Nos comprometemos a contestarle en 24 horas.

Puede encontrar respuesta a las preguntas más frecuentes en imoulife.com/support/help



Contenido del paquete

ES

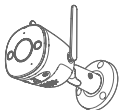

Cámara x 1



Mapa de
posicionamiento x 1

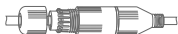

Conector a prueba
de agua x1



Juego de tornillos x 1



Guía de inicio rápido x 1

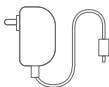

Alimentador x 1

Introducción a la cámara

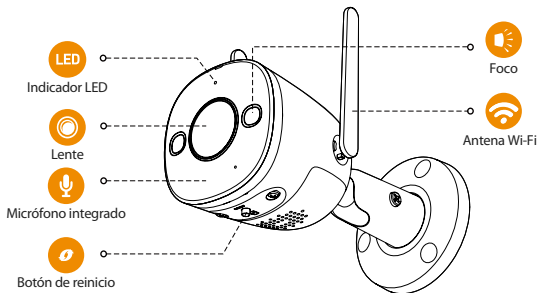

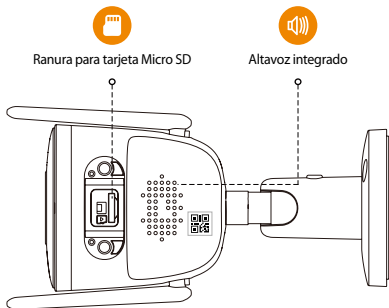

El patrón de los indicadores LED se incluye en la siguiente tabla.

Estado LED	Estado del aparato
APAGADA	<ul style="list-style-type: none"> ● Apagada/LED apagada ● Nuevo arranque después del reinicio
Luz roja encendida	<ul style="list-style-type: none"> ● Arranque ● Avería del dispositivo
Luz verde parpadeante	<ul style="list-style-type: none"> ● En espera de la red
Luz verde encendida	<ul style="list-style-type: none"> ● Funcionando correctamente
Luz derecha parpadeante	<ul style="list-style-type: none"> ● Fallo de conexión de red
Luz verde y luz roja parpadeando alternativamente	<ul style="list-style-type: none"> ● Actualización de firmware

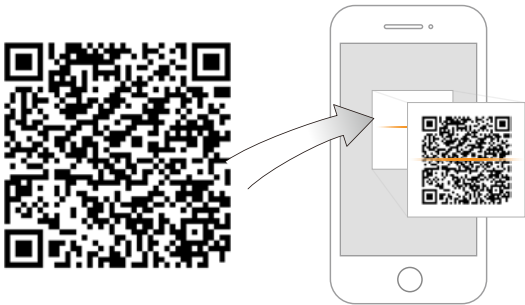

i Consejos

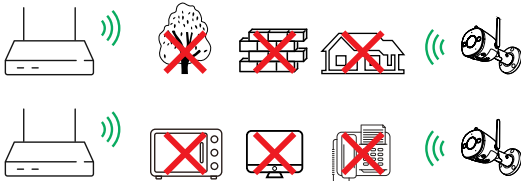

Para garantizar el mejor rendimiento inalámbrico posible, por favor asegúrese de que no hay obstáculos ni interferencias electromagnéticas entre la cámara y el enrutador.

2

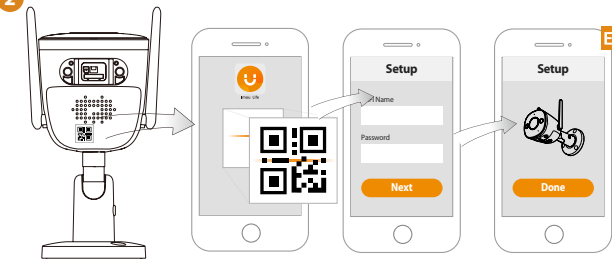

ES

3 Instalación de la cámara

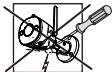
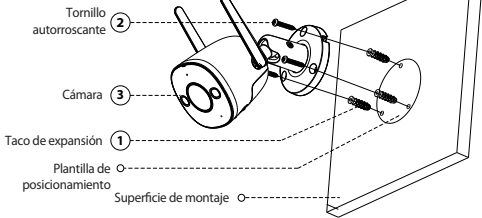

DC
12V1A

Solución de problemas

ES

Problema	Solución
No se puede configurar la cámara	<ul style="list-style-type: none">• Compruebe que su aparato móvil y la cámara están dentro del alcance de su router wifi.• Compruebe que el indicador LED de la cámara parpadea en color verde antes de comenzar la configuración.
La aplicación indica «Fallo al configurar la red del dispositivo»	<ul style="list-style-type: none">• Reinicie su cámara y conéctela de nuevo.• Algunas cámaras solo soportan 2,4 GHz, mientras que algunos routers tienen banda dual, 2.4G/5G. Compruebe que solo conecta a 2,4 GHz.
La aplicación indica « fallo al vincular»	<p>La cámara ya está conectada al wifi, pero el enrutador está:</p> <ul style="list-style-type: none">• Desconectado de Internet• Estado de la red deficiente• La señal de wifi no es estable debido a obstáculos o interferencia electrónica
Sin imagen / señal	<ul style="list-style-type: none">• Compruebe que el indicador LED de la cámara está encendido permanentemente en verde. De lo contrario, consulte la sección «Estado del LED» para conocer los detalles.• Compruebe que la cámara está adecuadamente conectada a la alimentación, usando el adaptador de corriente incluido.• Intente volver a ubicar la cámara, enrutador o ambos para mejorar la potencia de la señal.
La imagen no es clara	<ul style="list-style-type: none">• Verifique que la cámara no esté sucia, ni tenga polvo ni telarañas. Limpie la lente con un paño suave y limpio.• Retire la cubierta de vinilo de la lente de la cámara.
No hay sonido	<ul style="list-style-type: none">• Compruebe que la función de sonido de la cámara esté encendida.• Compruebe que el sonido en el dispositivo de visualización esté alto.
No funciona la detección de personas	<ul style="list-style-type: none">• Compruebe que esté activada la «detección de personas» en la pantalla de configuración del dispositivo en la aplicación Imou Life.
El teléfono no lee el código QR	<ul style="list-style-type: none">• Limpie la lente de la cámara en su teléfono móvil• Compruebe que el código QR recibe suficiente luz• No mantenga el código QR demasiado cerca de la cámara

Guide de démarrage rapide

Bullet 2 4MP

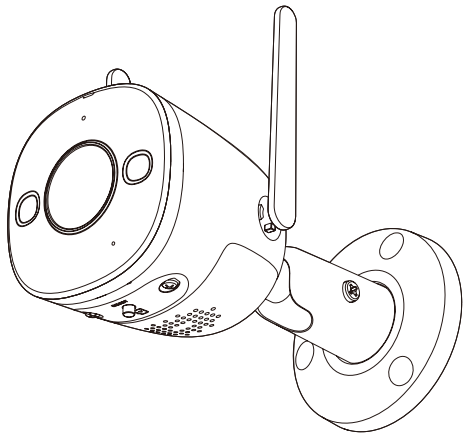

Bienvenue

FR

Merci d'avoir choisi IMOU.

Nous nous consacrons à fournir des produits pour la maison intelligente plus faciles à utiliser. Si vous rencontrez des difficultés lors de l'utilisation du produit, veuillez contacter notre équipe technique avant de renvoyer votre produit.

Notre courriel de service : service.global@imoulife.com

Nous nous engageons à vous répondre dans les 24 heures.

Les questions les plus fréquemment posées peuvent être consultées sur le site imoulife.com/support/help



Contenu de l'emballage

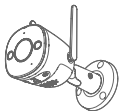

Caméra x 1



Schéma de positionnement x 1

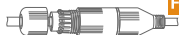

Connecteur étanche x1



Jeu de vis x 1



Guide de démarrage rapide x 1

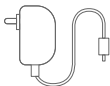

Adaptateur d'alimentation x 1

Introduction à la caméra

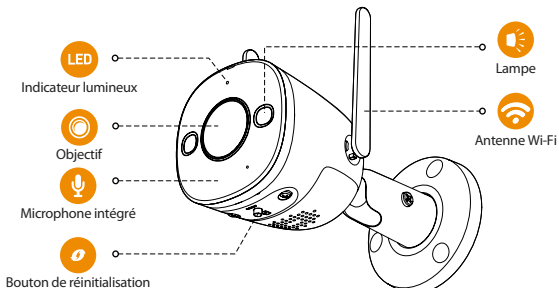

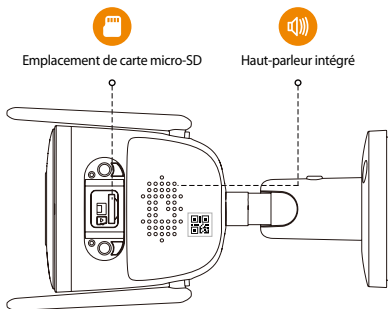

Le schéma des voyants est inclus dans le tableau suivant.

Statut du voyant	État de l'appareil
ARRÊT	<ul style="list-style-type: none"> ● Éteint/Voyant éteint ● Redémarrage après remise à zéro
Allumé en rouge	<ul style="list-style-type: none"> ● Amorçage ● Fonctionnement défectueux de l'appareil
Clignotant en vert	<ul style="list-style-type: none"> ● En attente de connexion réseau
Allumé en vert	<ul style="list-style-type: none"> ● Fonctionnement normal
Clignotement du voyant droit	<ul style="list-style-type: none"> ● Échec de connexion au réseau
Voyant vert et voyant rouge clignotant en alternance	<ul style="list-style-type: none"> ● Mise à jour du micrologiciel

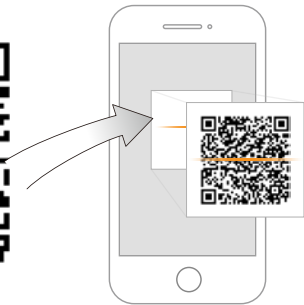

FR



Imou Life



Conseils

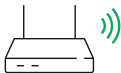
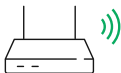

Pour garantir les meilleures performances sans fil possible, veuillez vous assurer qu'il n'y a pas d'obstacles ni d'interférences électromagnétiques entre la caméra et le routeur.

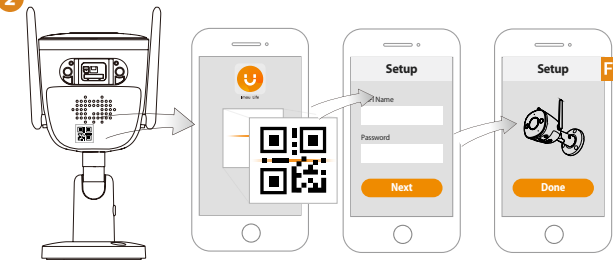
2

FR

3 Installation de la caméra

Vis autotaraudeuse ②

Caméra ③

Cheville à expansion ①

Patron d'installation ○

Surface de montage ○

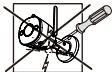
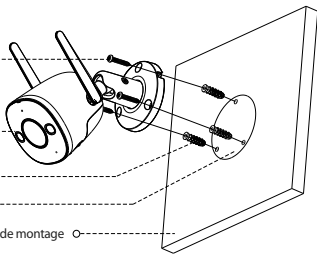

DC
12V1A

Dépannage

Problème	Solution
Impossible d'installer une caméra	<ul style="list-style-type: none">• Assurez-vous que votre appareil mobile et la caméra sont à portée de votre routeur Wi-Fi.• Assurez-vous que le voyant de la caméra clignote en vert avant de commencer la configuration.
L'APP indique « Échec de la configuration du réseau de l'appareil »	<ul style="list-style-type: none">• Réinitialisez votre caméra et rebranchez-la.• Certaines caméras ne prennent en charge que la bande 2,4 GHz, tandis que certains routeurs ont une double bande, 2,4 GHz/5 GHz. Assurez-vous de ne vous connecter que sur la bande 2,4 GHz.
L'application indique « Échec de la liaison »	La caméra est déjà connectée au Wi-Fi, mais le routeur est : <ul style="list-style-type: none">• Non connecté à Internet• Mauvais état du réseau• Le signal Wi-Fi n'est pas stable en raison d'obstacles ou d'interférences électroniques.
Pas d'image/de signal	<ul style="list-style-type: none">• Assurez-vous que le voyant de la caméra clignote en vert de façon continue. Voir la section « État du voyant » pour plus de détails, le cas échéant.• Assurez-vous que la caméra est correctement connectée à l'alimentation en utilisant l'adaptateur d'alimentation USB prévu à cet effet.• Essayez de repositionner la caméra, le routeur ou les deux pour améliorer la puissance du signal.
L'image n'est pas claire	<ul style="list-style-type: none">• Vérifiez que l'objectif de la caméra ne contient pas de saleté, de poussière ou de toiles d'araignées. Nettoyez la lentille à l'aide d'un chiffon doux et propre.• Retirez le couvercle en vinyle de l'objectif de la caméra.
Pas de son	<ul style="list-style-type: none">• Assurez-vous que la fonction audio de la caméra est activée.• Assurez-vous que le son est allumé sur l'appareil de visualisation.
La détection humaine ne fonctionne pas	<ul style="list-style-type: none">• Assurez-vous d'avoir activé la « Détection humaine » dans l'écran des paramètres de l'appareil de l'application Imou Life.
Le téléphone ne lit pas le code QR	<ul style="list-style-type: none">• Nettoyez l'objectif de la caméra de votre smartphone• Veillez à ce que le code QR soit suffisamment clair• Ne tenez pas le code QR trop près de la caméra

Guida Rapida

Bullet 2 4MP

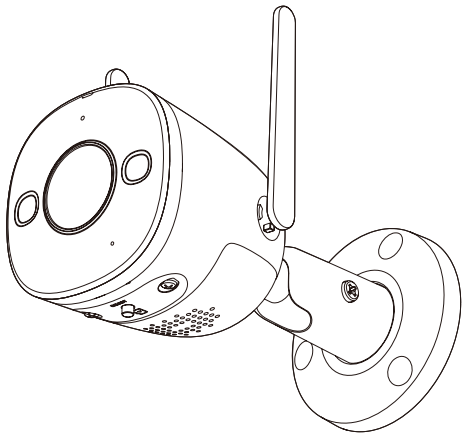

Benvenuti

IT

Grazie per aver scelto IMOU.

Il nostro obiettivo è quello di fornire prodotti per la domotica più facili da utilizzare. In caso di problemi durante l'utilizzo del prodotto, si prega di contattare il nostro team di assistenza prima di restituire il prodotto.

La nostra e-mail per il servizio di assistenza: service.global@imoulife.com

Promettiamo di rispondere entro 24 ore.

Le risposte alle domande più frequenti sono disponibili all'indirizzo imoulife.com/support/help



Contenuto della confezione

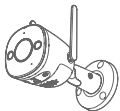

Telecamera x 1



Schema di
posizionamento x 1

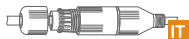

Connettore impermeabile x1



Confezione di viti x 1



QSG x 1

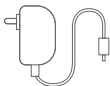

Alimentatore x 1

Introduzione alla telecamera

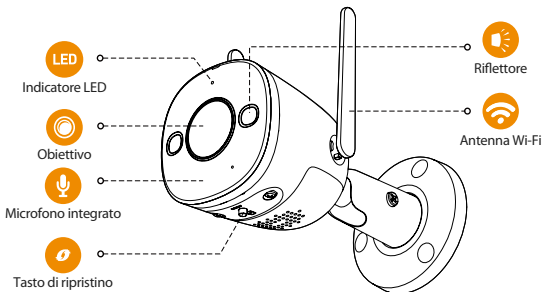

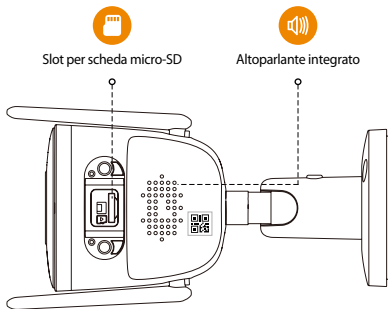

Gli indicatori LED sono descritti nella tabella seguente.

Stato LED	Stato dispositivo
SPENTO	<ul style="list-style-type: none"> ● Spento/LED spento ● Riavvio dopo il ripristino
Luce rossa accesa	<ul style="list-style-type: none"> ● Avvio ● Malfunzionamento del dispositivo
Luce verde lampeggiante	<ul style="list-style-type: none"> ● In attesa di rete
Luce verde accesa	<ul style="list-style-type: none"> ● Funzionamento normale
Luce rossa lampeggiante	<ul style="list-style-type: none"> ● Connessione di rete non riuscita
La luce verde e quella rossa lampeggiano in alternanza	<ul style="list-style-type: none"> ● Aggiornamento del firmware

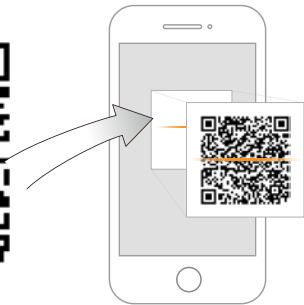

IT



Imou Life



Suggerimenti

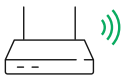

Per garantire le migliori prestazioni wireless possibili, assicurarsi che non ci siano ostacoli e interferenze elettromagnetiche tra la telecamera e il router.

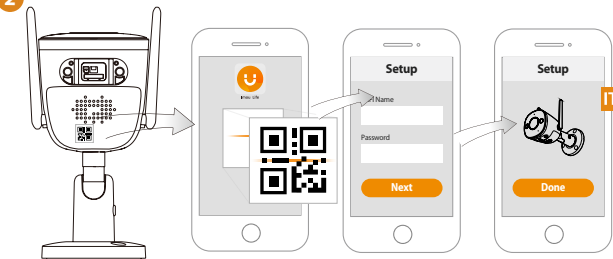
2

3 Installazione della telecamera

Vite autofilettante **2**

Telecamera **3**

Bullone di espansione **1**

Dima di posizionamento

Superficie di montaggio

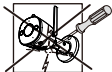
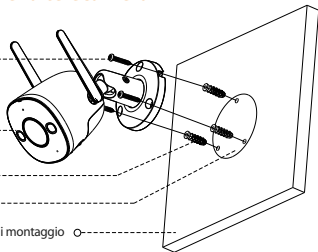

DC
12V1A

Risoluzione dei problemi

Problema	Soluzione
Impossibile impostare la telecamera	<ul style="list-style-type: none">• Assicurarsi che il dispositivo mobile e la telecamera si trovino nel raggio d'azione del router Wi-Fi.• Assicurarsi che l'indicatore LED della telecamera lampeggi con luce verde prima di cominciare l'impostazione.
L'app mostra il messaggio "Impossibile configurare la rete del dispositivo"	<ul style="list-style-type: none">• Resetare la telecamera e collegarla di nuovo.• Alcune telecamere supportano solo la frequenza 2,4 GHz, mentre alcuni router sono a doppia banda (2,4/5 GHz). Accertarsi di utilizzare solo la connessione da 2,4 GHz.
L'app mostra la notifica "Associazione non riuscita"	La telecamera è già connessa alla rete Wi-Fi, ma il router: <ul style="list-style-type: none">• Non è connesso a Internet• Ha una scarsa qualità del segnale di rete• Il segnale Wi-Fi non è stabile a causa di ostacoli e interferenze elettroniche
Assenza di immagine/segnale	<ul style="list-style-type: none">• Assicurarsi che l'indicatore LED della telecamera lampeggi con luce verde. In caso contrario, fare riferimento alla sezione "Stato LED" per maggiori dettagli.• Assicurarsi che la telecamera sia correttamente connessa alla fonte di alimentazione tramite l'alimentatore USB.• Provare a modificare la posizione della telecamera o del router o di entrambi i dispositivi per migliorare la potenza del segnale.
L'immagine non è chiara	<ul style="list-style-type: none">• Controllare che l'obiettivo della fotocamera sia libero da sporco, polvere o ragnatele. Pulire l'obiettivo con un panno morbido inumidito.• Rimuovere il coperchio in vinile dall'obiettivo della telecamera.
Non c'è suono	<ul style="list-style-type: none">• Accertarsi che la funzione audio della telecamera sia attiva.• Accertarsi che l'audio del dispositivo ricevente sia acceso.
Il rilevamento persone non funziona	<ul style="list-style-type: none">• Accertarsi di aver abilitato la funzione "Rilevamento persone" nella schermata Impostazioni dispositivo dell'app Imou Life.
Il telefono non legge il codice QR	<ul style="list-style-type: none">• Pulire l'obiettivo della fotocamera dello smartphone• Accertarsi che il codice QR sia ben illuminato• Non tenere il codice QR troppo vicino alla fotocamera dello smartphone

Snelstartgids

Bullet 2 4MP

NL

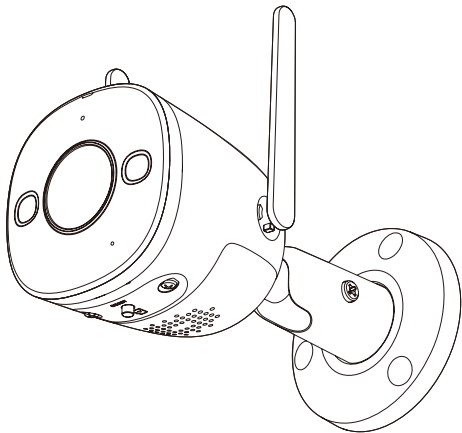

Welkom

Bedankt dat u voor Imou heeft gekozen.

NL

Onze toewijding is om u eenvoudige Smart Home producten te bieden. Als u problemen ervaart met het gebruik van uw product, neem dan eerst contact op met onze service team: service.global@imoulife.com



Inhoud verpakking

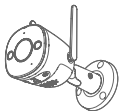

Camera x 1



Positioneringskaart x1

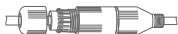

Waterdichte connector x1

NL



Schroevenset x1



QSG x1

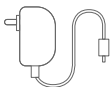

Voedingsadapter x1

Introductie camera

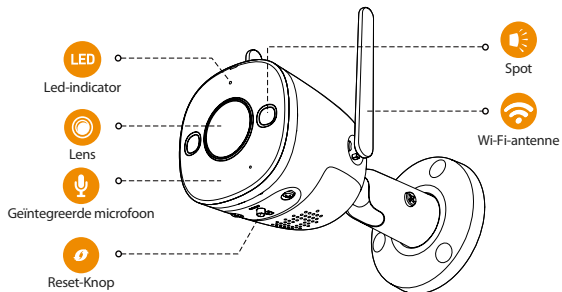

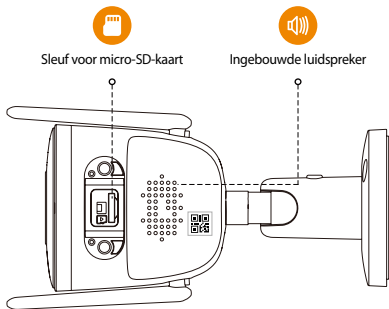

Het patroon van led-indicatoren wordt weergegeven in de volgende tabel.

Ledstatus	apparaatstatus
UIT	<ul style="list-style-type: none"> ● Uitgeschakeld/led uit ● Opnieuw opstarten na reset
Rood lampje aan	<ul style="list-style-type: none"> ● bezig met opstarten ● Storing van het apparaat
Groen lampje knippert	<ul style="list-style-type: none"> ● Wachten op netwerk
Groen lampje aan	<ul style="list-style-type: none"> ● Werkt zoals dat moet
Rood lampje knippert	<ul style="list-style-type: none"> ● Netwerkverbinding mislukt
Groen lampje en rood lampje knipperen afwisselend	<ul style="list-style-type: none"> ● Bijwerken firmware

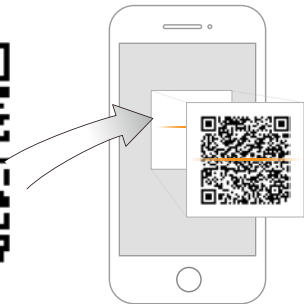

NL



Imou Life



Tips

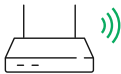

Zorg voor de best mogelijke draadloze prestatie dat er geen obstakels en elektromagnetische interferentie tussen de camera en router aanwezig zijn.

2

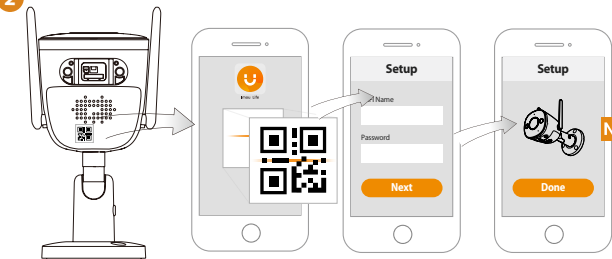

3 Het installeren van de camera

Zelftappende schroef ②

Camera ③

Expansiebout ①

Montageoverzicht

Montage-oppervlak

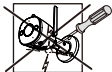
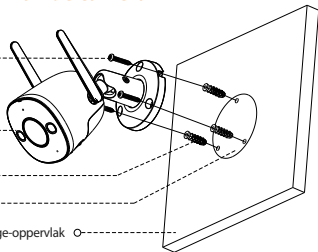

DC
12V1A

Probleemoplossing

Probleem	Oplossing
Kan de camera niet instellen	<ul style="list-style-type: none">• Zorg ervoor dat uw mobiele apparaat en de camera zich binnen het bereik van uw wifi-router bevinden.• Zorg ervoor dat de led-indicator op de camera groen knippert voordat u met de installatie begint.
De app zegt "Instellen apparaatnetwerk mislukt"	<ul style="list-style-type: none">• Reset uw camera en verbind deze opnieuw.• Sommige camera's ondersteunen enkel 2,4 GHz, terwijl sommige routers een dubbele band hebben, namelijk 2,4 GHz en 5 GHz. Zorg ervoor dat u alleen verbinding maakt met de 2,4 GHz band.
De app zegt "Verbinding mislukt"	<p>De camera is al verbonden met wifi, maar:</p> <ul style="list-style-type: none">• De router is niet verbonden met het internet• De router heeft een slechte netwerkstatus• Het wifi-sigitaal van de router is niet stabiel vanwege obstakels of elektronische interferentie
Geen beeld/signaal	<ul style="list-style-type: none">• Zorg ervoor dat de led-indicator op de camera groen knippert. Zie de sectie "ledstatus" voor details indien dit niet het geval is.• Zorg ervoor dat de camera voorzien is van stroom door gebruik te maken van de meegeleverde USB-spanningsadapter.• Probeer de camera, router of beide te verplaatsen om de signaalsterkte te verbeteren.
Beeld is niet duidelijk	<ul style="list-style-type: none">• Controleer de cameralens op vuil, stof en spinnenwebben. Reinig de lens met een zachte, schone doek.• Verwijder het vinyldeksel op de cameralens.
Geen audio	<ul style="list-style-type: none">• Zorg ervoor dat de audiofunctie op de camera is ingeschakeld.• Zorg ervoor dat audio wordt ingeschakeld op het kijkapparaat.
Personendetectie werkt niet	<ul style="list-style-type: none">• Zorg ervoor dat u "Personendetectie" hebt ingeschakeld in het scherm Apparaatinstellingen in de Imou Life-app.
Telefoon leest geen QR-code	<ul style="list-style-type: none">• Reinig de cameralens van uw telefoon• Zorg ervoor dat de QR-code voldoende belicht wordt• Houd de QR-code niet te dicht bij de camera

Guia rápido

Bullet 2 4MP

PT

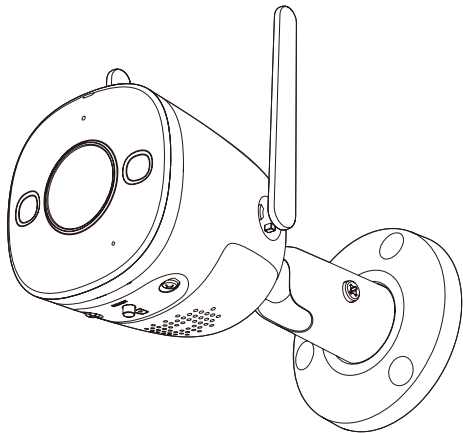

Bem-vindo

Obrigado por escolher a IMOU.

Estamos empenhados em fornecer produtos inteligentes e simplificados para o lar. Se tiver problemas ao utilizar o produto, contacte a nossa equipa de assistência antes de devolver o produto.

PT

O nosso e-mail de assistência: service.global@imoulife.com
Prometemos responder no prazo de 24 horas.

Pode encontrar as Perguntas frequentes em imoulife.com/support/help



Conteúdo da embalagem

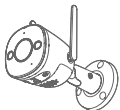

Câmara x 1



Mapa de posicionamento x1

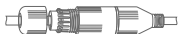

Conector impermeável x1



Pacote de parafusos x1



Guia de início rápido x1

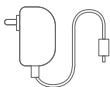

Adaptador de energia x1

PT

Apresentação da câmara

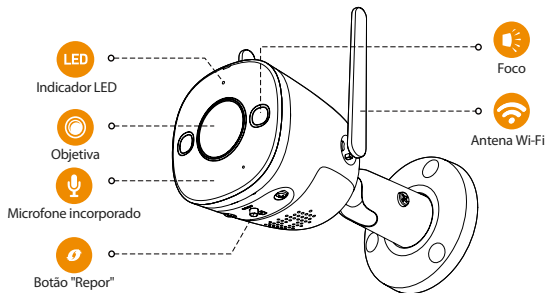

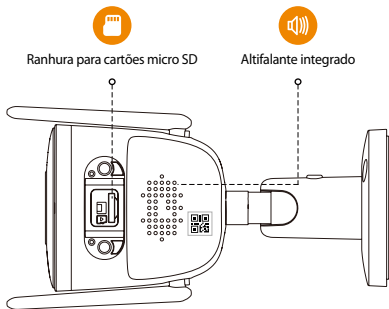

O padrão dos indicadores LED está incluído na tabela seguinte.

Estado do LED	Estado do dispositivo
DESLIGADO	<ul style="list-style-type: none"> ● Desligado/LED desligado ● Reiniciar após a reposição
Luz vermelha acesa	<ul style="list-style-type: none"> ● Arranque ● Avaria do dispositivo
Luz verde intermitente	<ul style="list-style-type: none"> ● À espera da rede
Luz verde acesa	<ul style="list-style-type: none"> ● A funcionar corretamente
Luz vermelha intermitente	<ul style="list-style-type: none"> ● Ligação à rede falhou
Luz verde e luz vermelha intermitentes alternadamente	<ul style="list-style-type: none"> ● Atualização do firmware

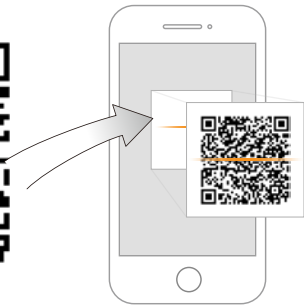

PT



Dicas

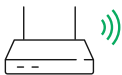

Para assegurar o melhor desempenho possível do sistema sem fios, certifique-se de que não existem obstáculos e interferência eletromagnética entre a câmara e o router.

2

PT

3 Instalar a câmaraParafuso autoperfurante **2**Câmara **3**Parafuso de expansão **1**

Mapa de posicionamento

Superfície de montagem

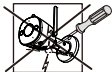
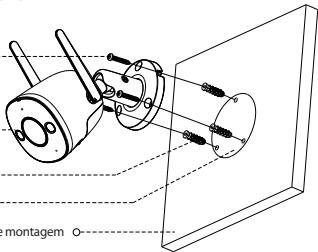
DC
12V1A

Solução de problema

Problema	Solução
Não é possível configurar a câmara	<ul style="list-style-type: none">• Certifique-se de que o dispositivo móvel e a câmara estão dentro do alcance do router de Wi-Fi.• Certifique-se de que o indicador LED na câmara está verde intermitente antes da configuração.
A app informa "A configuração da rede do dispositivo falhou"	<ul style="list-style-type: none">• Reponha a câmara e ligue-a novamente.• Algumas câmaras suportam apenas 2,4 GHz, enquanto alguns routers possuem banda dupla, 2,4 G/5G. Certifique-se de que liga apenas a 2,4 GHz.
A app informa "A associação falhou"	A câmara já está ligada ao Wi-Fi, mas o router: <ul style="list-style-type: none">• Não está ligado à Internet• O estado da rede é fraco• O sinal Wi-Fi não é estável devido a obstáculos ou interferência eletrónica
Sem imagem/sinal	<ul style="list-style-type: none">• Certifique-se de que o indicador LED na câmara está verde fixo. Consulte a secção "Estado do LED" para obter detalhes, caso seja necessário.• Certifique-se de que a câmara está devidamente ligada com o adaptador de corrente USB.• Tente reposicionar a câmara, o router ou ambos para melhorar a força do sinal.
A imagem não está nítida	<ul style="list-style-type: none">• Verifique a objetiva da câmara para verificar a existência de sujidade, pó e teias de aranha. Limpe a objetiva com um pano limpo e macio.• Retire a tampa de vinil da objetiva da câmara.
Sem áudio	<ul style="list-style-type: none">• Certifique-se de que a função de áudio na câmara está ativada.• Certifique-se de que o áudio está ligado no dispositivo de visualização.
A deteção humana não está operacional	<ul style="list-style-type: none">• Certifique-se de que ativou a "Deteção humana" no ecrã Definições do dispositivo da app Imou Life.
O telefone não consegue ler o código QR	<ul style="list-style-type: none">• Limpe a objetiva da câmara do smartphone• Certifique-se de que existe luminosidade suficiente no código QR• Não coloque o código QR demasiado perto da câmara

imou

Enjoy Smart Life



Available on the
App Store

GET IT ON
Google play

CE FC CCC UL ISO 9001:2000

 @imouglobal

 service.global@imoulife.com

 www.imoulife.com