

made in Italy

1:12 scale

No 4708

# Alfa Romeo 8C 2300 Roadster

EN

The Alfa Romeo 8C can be considered as one of the most famous sports cars of the 1930s. The car's name derives from the engine adopted: an 8-cylinder in-line supercharged engine with a displacement of 2,336 cc. The Alfa Romeo could be considered the "state of art" for technology, innovative solutions and performances. Characterized by an impressive reliability and driveability the "8C" achieved significant victories in international car racing competitions. It linked its name to the famous Italian driver Tazio Nuvolari that won, among the others, the Targa Florio race in Sicily and the prestigious Italian Grand Prix at Monza. This last victory gave the "Monza" name to the twin seater GP car. From the racing version, a production batch of almost 200 vehicles was produced for the private markets and to be used on the normal road. To celebrate the 110th anniversary of the famous Italian manufacturer we are releasing the two-seater Sport version of the 1930's. The car was distributed at that time via the Alfa Romeo sales network to those customers wealthy enough to purchase the most successful sports car of the period.

IT

L'Alfa Romeo 8C può essere considerata come una delle più celebri auto sportive degli anni '30. Il nome della vettura deriva dal propulsore adottato: un motore 8 cilindri in linea da 2.336 cc sovralimentato con compressore diventato un'icona nel panorama automobilistico del periodo. La 8C poteva considerarsi infatti lo "stato dell'arte" per tecnologia, soluzioni tecniche e prestazioni. Caratterizzata da una straordinaria tenuta di strada e da una eccellente affidabilità, l'Alfa Romeo ottenne significative vittorie sportive su numerosi circuiti internazionali e legò il suo nome al celebre pilota mantovano Tazio Nuvolari. Tra le imprese più note la vittoria nella Targa Florio nel 1931 e nel Gran Premio d'Italia. Quest'ultima vittoria contribuì anche al nome dell'auto GP due posti affiancati che, per celebrare l'impresa, venne chiamata "Monza". Dalla versione da competizione venne realizzato anche un lotto produttivo destinato al mercato stradale di quasi 200 veicoli. Per celebrare i 110 anni di attività del celebre costruttore italiano, viene proposta la versione Sport a due posti disponibile presso la rete di vendita Alfa Romeo dell'epoca per chi desiderava acquistare l'auto sportiva più vittoriosa del periodo.

DE

Der Alfa Romeo 8C gilt als einer der bekanntesten Sportwagen der 1930er-Jahre. Der Name des Autos leitet sich vom eingesetzten Motor ab: Einem 2336 ccm 8-Zylinder-Motor mit einem Kompressor, der in der damaligen Automobilszene zur Ikone wurde. Der 8C spiegelte mit seinen Lösungen und Leistungen den neuesten „Stand der Technik“ wider. Der Alfa Romeo zeichnete sich durch eine außergewöhnliche Straßenlage und eine hervorragende Zuverlässigkeit aus. Auf zahlreichen internationalen Rennstrecken erzielte er bedeutende sportliche Erfolge; mit ihm verbindet man auch den Namen des berühmten Piloten Tazio Nuvolari aus Mantova. Zu den bekanntesten Siegen zählt auch der Sieg bei der Targa Florio im Jahr 1931 und der erste Platz im Grand Prix von Italien. Dieser Sieg verhalf dem zweiseitigen GP-Wagen auch zu seinem Namen: Er wurde zur Feier des 1. Podiumsplatzes „Monza“ genannt. Die Rennvariante diente auch zur Vorlage für eine Produktionsserie von fast 200 Fahrzeugen für den Straßenmarkt. Zur Feier seines 110-jährigen Bestehens präsentiert der berühmte italienische Hersteller die zweiseitige Sportversion, über das damalige Vertriebsnetz von Alfa Romeo erhältlich für diejenigen, die den erfolgreichsten Sportwagen der damaligen Zeit kaufen wollten.

FR

L'Alfa Romeo 8C peut être considérée comme l'une des voitures de sport les plus célèbres des années 30. Le nom de la voiture vient du propulseur adopté : un moteur 8 cylindres en ligne de 2 336 cc suralimenté avec un compresseur qui est devenu une icône dans le panorama automobile de l'époque. La 8C peut être considérée comme « l'état de l'art » en termes de technologie, de solutions techniques et de performance. Caractérisée par une tenue de route extraordinaire et une excellente fiabilité, Alfa Romeo remporta d'importantes victoires sportives sur de nombreux circuits internationaux et lia son nom au célèbre pilote originaire de Mantoue, Tazio Nuvolari. Parmi ses exploits les plus célèbres, on peut citer sa victoire dans la Targa Florio en 1931 et dans le Grand Prix d'Italie. Cette dernière victoire contribua également au nom de la voiture GP biplace côte à côte qui, pour célébrer l'exploit, a été baptisée «Monza». De la version de compétition, un lot de production destiné au marché routier de près de 200 véhicules fut également réalisé. Pour célébrer les 110 ans d'activité du célèbre constructeur italien, la version Sport biplace est proposée, disponible auprès du réseau de vente Alfa Romeo de l'époque pour ceux qui souhaitent acheter la voiture de sport la plus aboutie de l'époque.

ES

El Alfa Romeo 8C puede considerarse como uno de los coches deportivos más famosos de los años treinta del siglo XX. El nombre del automóvil deriva del propulsor adoptado: un motor de 8 cilindros en línea de 2.336 cc sobrealimentado con compresor, que se convirtió en un icono en el panorama automovilístico del periodo. De hecho, el 8C podía considerarse el "estado de la técnica" por su tecnología, soluciones técnicas y prestaciones. Caracterizado por una extraordinaria adherencia en carretera y por una excelente fiabilidad, el Alfa Romeo obtuvo victorias deportivas significativas en numerosos circuitos internacionales y unió su famoso nombre al célebre piloto de Mantua Tazio Nuvolari. Entre las hazañas más conocidas cabe destacar la victoria en la Targa Florio en 1931 y en el Gran Premio de Italia. Esta última victoria contribuyó también al nombre del coche GP de dos plazas que, para celebrar la hazaña, fue llamado "Monza". A partir de la versión de competición se realizó también un lote de fabricación destinado al mercado vial de casi 200 vehículos. Para celebrar los 110 años de actividad del célebre fabricante italiano, se presenta la versión Sport de dos plazas, disponible en la red de ventas de Alfa Romeo de la época, para quienes deseaban comprar el coche deportivo que más certámenes había ganado en ese período.

RU

Alfa Romeo 8C можно считать одним из самых знаменитых спортивных автомобилей 30-х годов. Название автомобиля происходит от установленного двигателя: 8-цилиндровый линейный двигатель объемом 2336 куб.см с компрессором. Он стал настоящей иконой среди автомобилей того времени. Модель 8C можно было считать «шедевром» того времени, что касается примененной технологии, технических решений и эксплуатационных характеристик. Характеризующийся превосходным сцеплением с дорожным полотном и отличной надежностью, Alfa Romeo одержал важные спортивные победы на многих международных автодромах и связал свое имя с легендарным пилотом Тацио Нуволари из г. Мантуя. Среди самых знаменательных побед можно назвать победу в гонке Targa Florio в 1931 г. и в Гран-при Италии. Последняя победа отразилась также в названии двухместного автомобиля класса Гран-при, в честь этого события в его название было добавлено «Монца». Была выпущена на рынок также партия автомобилей в дорожной версии в количестве почти 200 экземпляров. В ознаменование 110-летия деятельности известной итальянской компании-производителя была предложена двухместная версия Sport, которую могут приобрести в сети продаж ретро-автомобилей Alfa Romeo все, желающие стать владельцами самого успешного спортивного автомобиля того времени.



- EN WARNING: Model for adult collector age 14 and over
- IT ATTENZIONE: Modello per collezionisti adulti di età superiore ai 14 anni
- FR ATTENTION: Modèle pour modélistes de 14 ans et plus.
- DE ACHTUNG: Modellbausatz für Modellbauer über 14 Jahre.
- NL WAARSCHWING: Geschikt voor 14 jaar en ouder.
- ES ATENCION: Modelo para modelistas mayores de 14 años.

## EN ATTENTION - Useful advice!

Study the instructions carefully prior to assembly. Remove parts from frame with a sharp knife or a pair of scissor and trim away excess plastic. Do not pull off parts. Assemble the parts in numerical sequence. Use plastic cement ONLY and use cement sparingly to avoid damaging the model. Black arrows indicate parts to be glued together. White arrows indicate on which frame the parts must be assembled WITHOUT using cement. These letters (A - B - C...) indicate on which frame the parts will be found. Paint small parts before detaching them from frame. Remove paint where parts are to be cemented. Crossed out parts must not be used.

## IT ATTENZIONE - Consigli utili!

Prima di iniziare il montaggio studiare attentamente il disegno. Staccare con molta cura i pezzi dalle stampate, usando un taglia-balsa oppure un paio di forbici e togliere con una piccola lima o con carta vetro fine eventuali sbavature. Mai staccare i pezzi con le mani. Montarli seguendo l'ordine delle numerazioni delle tavole. Eliminare dalla stampata il numero del pezzo appena montato facendogli sopra una croce. Le frecce nere indicano i pezzi da incollare, le frecce bianche indicano i pezzi da montare senza colla. Usare solo colla per polistirolo. Le lettere (A - B - C...) ai lati dei numeri indicano la stampata ove si trova il pezzo da montare. I pezzi sbarrati da una croce non sono da utilizzare.

## DE ACHTUNG - Ein nützlicher Rat!

Vor der Montage die Zeichnung aufmerksam studieren. Die einzelnen Montageteile mit einem Messer oder einer Schere vom Spritzling sorgfältig entfernen. Eventuelle Grate werden mit einer Klinge oder feinem Schmirgelpapier beseitigt. Keinesfalls die Montageteile mit den Händen entfernen. Bei der Montage der Teilenummerierung folgen. Pfeile zeigen die zu klebenden Teile während die weissen Pfeile die ohne Leim zu montierenden Teile anzeigen. Bitte nur Plastikklebstoff verwenden. Die Buchstaben (A - B - C...) neben den Nummern zeigen auf welchem Spritzling der zu montierende Teil zu finden ist. Die mit einem Kreuz markierten Teile sind nicht zu verwenden.

## FR ATTENTION - Conseils utiles!

Avant de commencer le montage, étudier attentivement le dessin. Détacher avec beaucoup de soin les morceaux des moules en usant un massicot ou bien un pair de ciseaux et couper avec une petite lame avec de papier de verre fin ébarbés éventuels. Jamais détacher les morceaux avec les mains. Monter les en suivant l'ordre de la numération des tables. Éliminer de la moule le numéro de la pièce qui vient d'être montée, en le bifant avec une croix. Les flèches noires indiquent les pièces à coller, les flèches blanches indiquent les pièces à monter sans colle. Employer seulement de la colle pour polystyrol. Les lettres (A - B - C...) aux côtés des numéros indiquent la moule où se trouve la pièces à monter. Les pièces marquées par une croix ne sont pas à utiliser.

## ES ATENCION - Consejos útiles!

Estudiar las instrucciones cuidadosamente antes de comenzar el montaje. Separar las piezas de las bandejas con un cuchillo afilado o un par de tijeras y retirar el exceso de plástico o rebada. No arrancar las piezas. Montar las piezas en orden numérico. Utilizar SOLAMENTE pegamento para plástico y en poca cantidad para evitar que se dane el modelo. Las flechas negras indican las piezas que se deben pegar juntas. Las flechas blancas indican las piezas que deben ensamblarse SIN usar pegamento. Las letras (A - B - C...) indican en que bandeja se encuentran las piezas. Pintar las piezas pequeñas antes de separarlas de la bandeja. Retirar la pintura de los lugares por donde se deban pegar las piezas.

## RU ПРЕДУПРЕЖДЕНИЕ - важные!

ПЕРЕД ТЕМ, КАК ПРИСТУПИТЬ К СБОРКЕ, ВНИМАТЕЛЬНО ИЗУЧИТЬ ЧЕРТЕЖ. ОЧЕНЬ ОСТОРОЖНО ОТСОЕДИНИТЬ РАСПЕЧАТАННЫЕ ЭЛЕМЕНТЫ, ИСПОЛЬЗОВАТЬ ДЛЯ ЭТОГО КАНЦЕЛСКИЙ НОЖ ИЛИ ПАРУ НОЖИЦ, СНЯТЬ НЕРОВНОСТИ С ПОМОЩЬЮ ТОНКОГО ЛЕЗВИЯ ИЛИ С ПОМОЩЬЮ АБРАЗИВНОЙ БУМАГИ. НЕ ОТСОЕДИНЯТЬ ЭЛЕМЕНТЫ РУКАМИ. ВЫПОЛНИТЬ СБОРКУ СОГЛАСНО ПОРЯДКУ НУМЕРАЦИИ ТАБЕЛИ, УДАЛИТЬ ИЗ СПИСКА ТОЛЬКО ТО СОБРАННОМУ ДЕТАЛЬ, ПЕРЕЧЕРКНУВ ЕЕ. ЧЕРНЫЕ СТРЕЛКИ УКАЗЫВАЮТ ДЕТАЛИ ДЛЯ СЦЕПЛЕНИЯ, БЕЛЫЕ СТРЕЛКИ УКАЗЫВАЮТ ДЕТАЛИ, КОТОРЫЕ СОБИРАЮТСЯ БЕЗ КЛЕЯ. ИСПОЛЬЗОВАТЬ ТОЛЬКО КЛЕЙ ДЛЯ ПЕНОПЛАСТА, БУКВЫ (А - В - С...) НА ПРОНУМЕРОВАННЫХ СТОРОНАХ УКАЗЫВАЮТ МЕСТ, ГДЕ НАХОДИТСЯ ДЕТАЛЬ. ПЕРЕЧЕРКНУТЫЕ ДЕТАЛИ НЕ ИСПОЛЬЗУЮТСЯ.

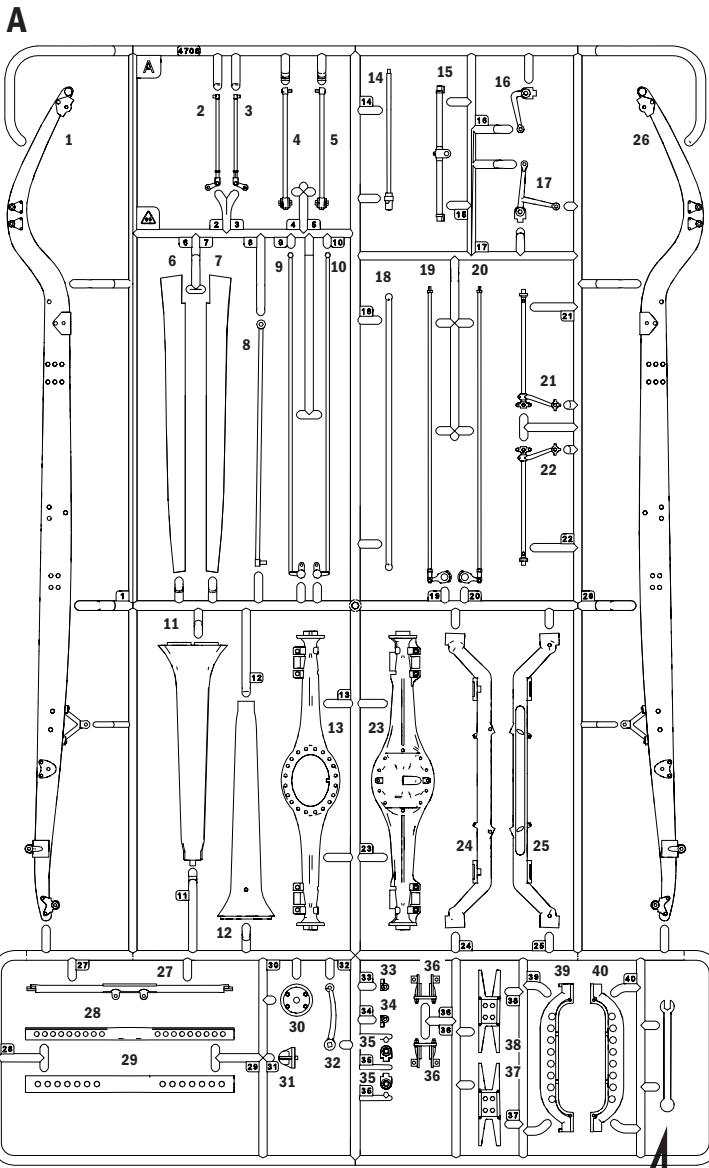

Please use this wrench for NUT 01

Usare come chiave inglese per il DADO 01

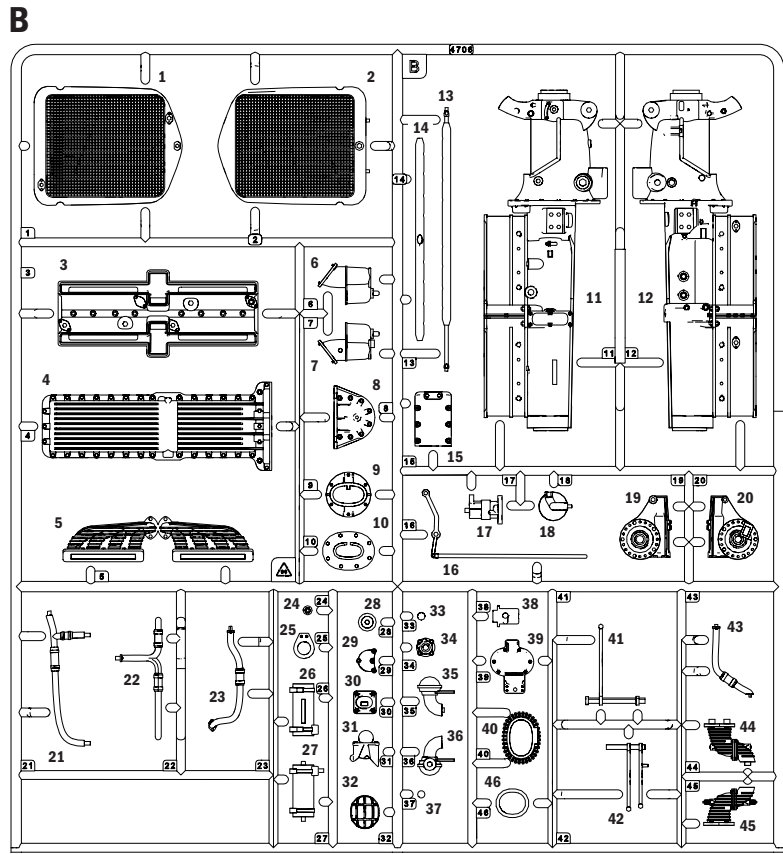

**I Chromed Parts**

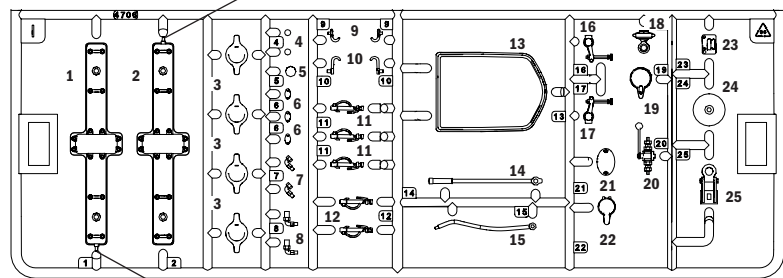

**WARNING!!!**  
DON'T CUT PIN

**WARNING!!!**  
DON'T CUT PIN

Remove chrome paint where parts are to be glued together

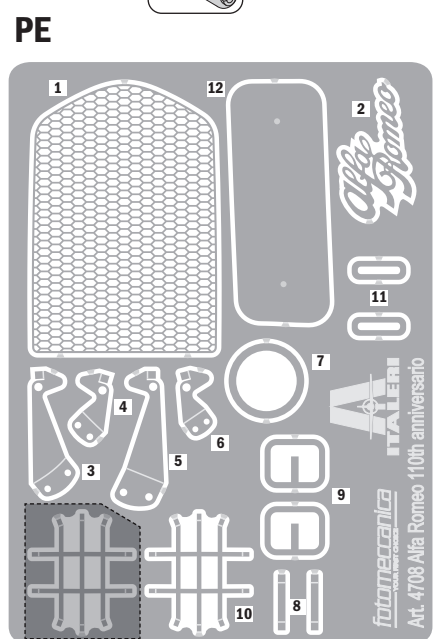
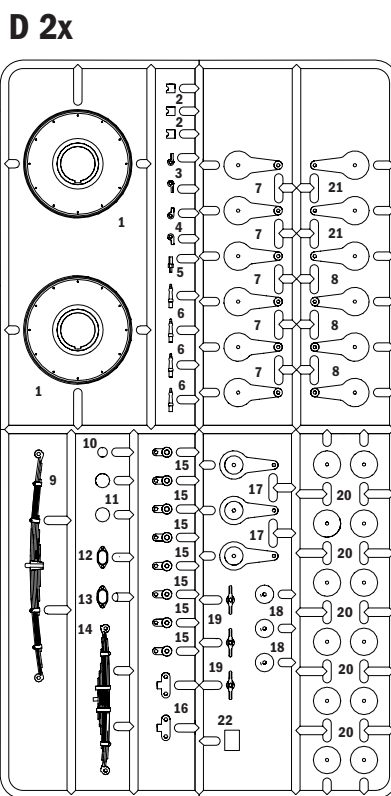
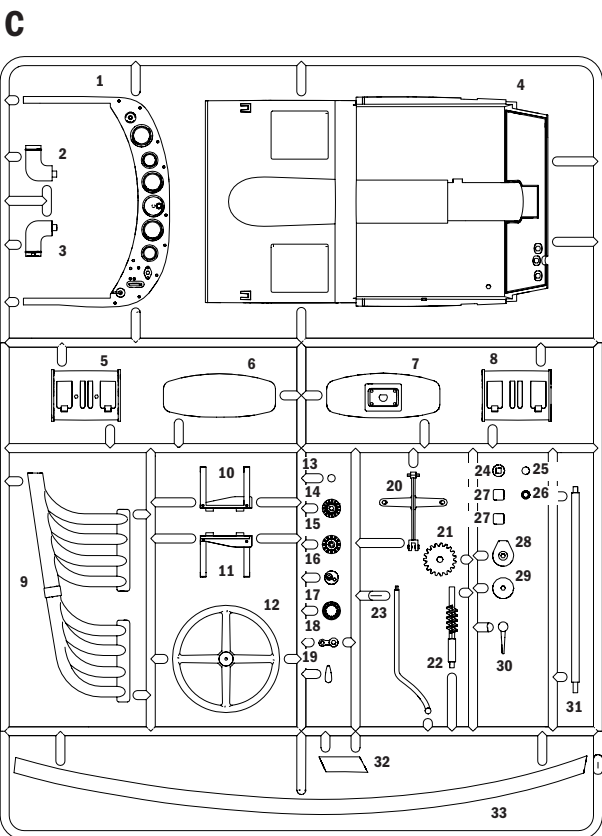

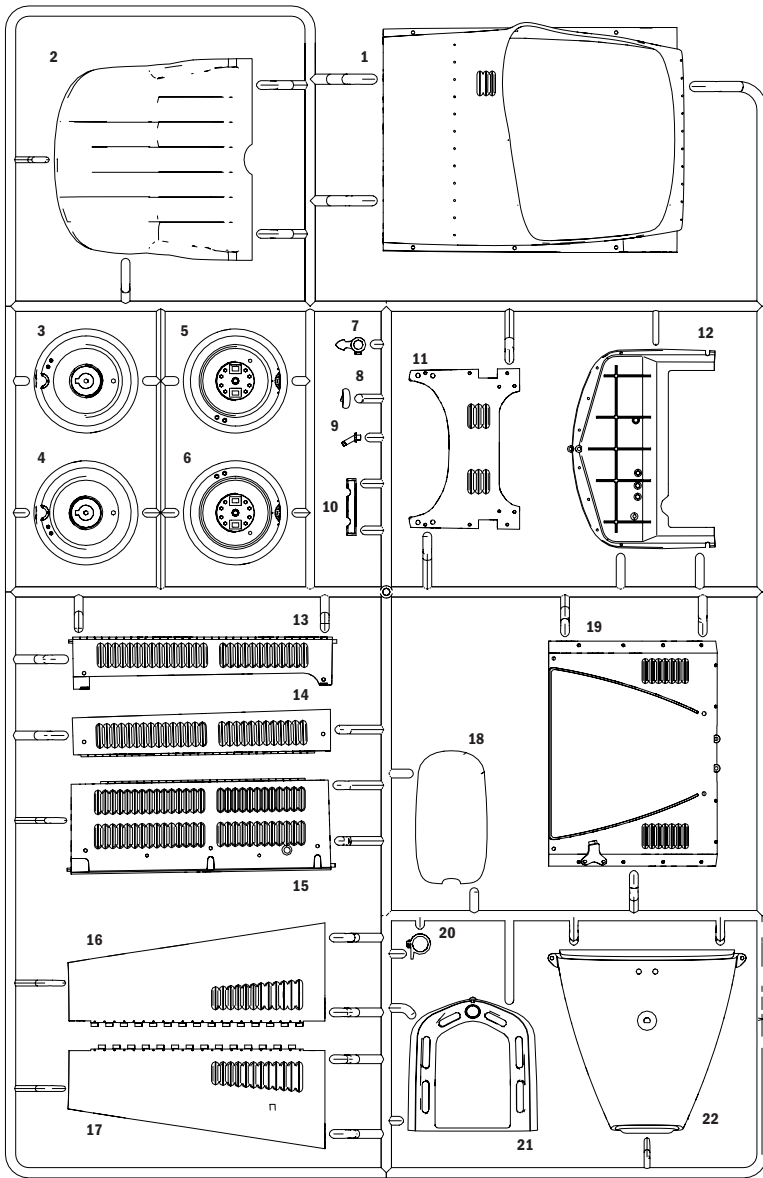
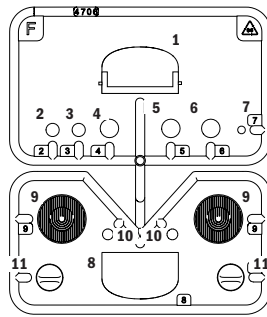
**E****F**

NYLON NET

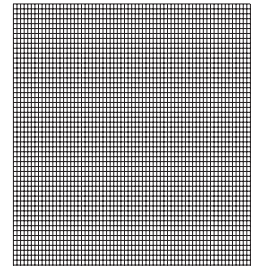

COPPER WIRE 200mm.

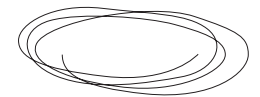

Fare nodo  
Making knot  
Faire nœud  
Making Knoten  
Hacer un nudo  
Het maken van node

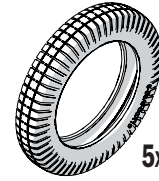

5x



Parti da non utilizzare  
Parts not for use  
Pièces à ne pas utiliser  
Telle werden nicht verwenden  
Partes a no utilizar  
Onderdelen niet te gebruiken



Ribadire a caldo  
Rivet hot  
River à chaud  
Warm ennieten  
Reforzar al calor  
Versterking van hot



Separare  
Cut  
Retirer  
Entfernen  
Separar  
Gesneden



Aprire i fori  
Drill holes  
Ouvrir les trous  
Die Locher Ausbohren  
Perforar los agujeros  
Open gaten

LEATHER (BELT)

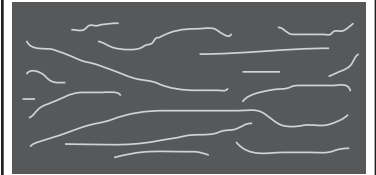

CUT AND BEND

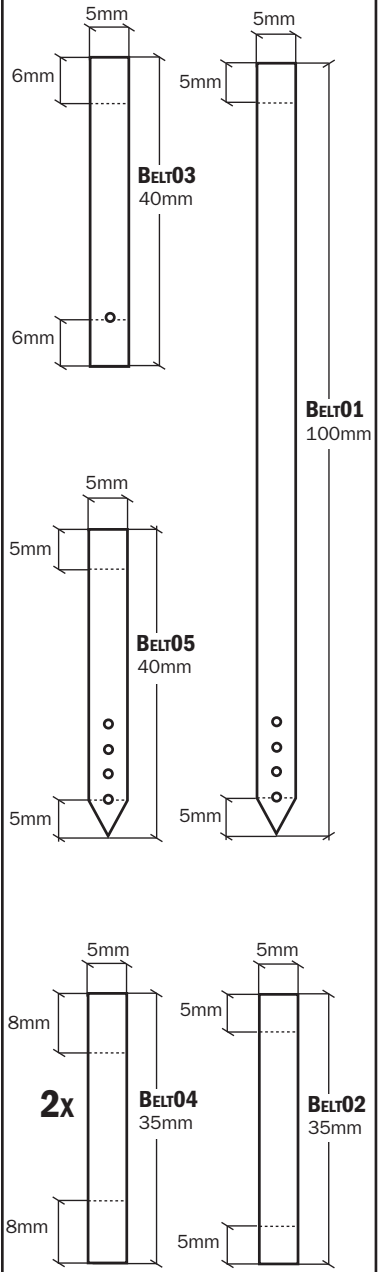
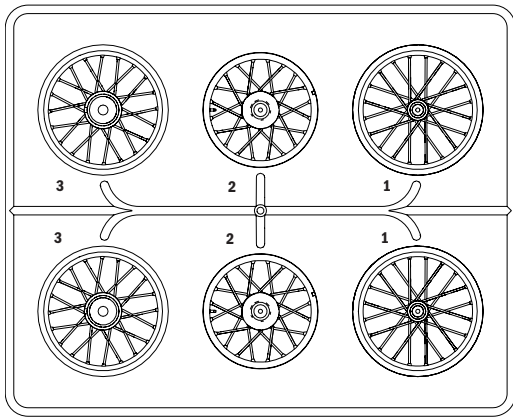
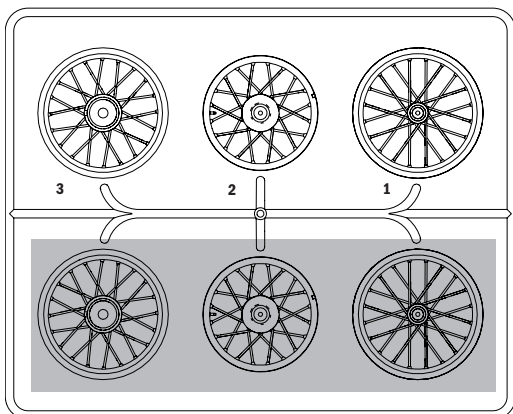
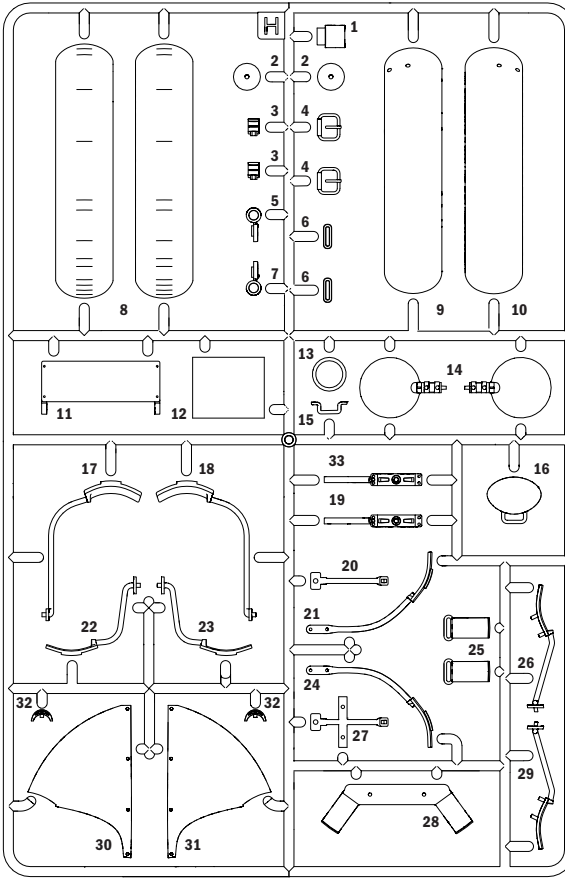
**G 2x****G****H**

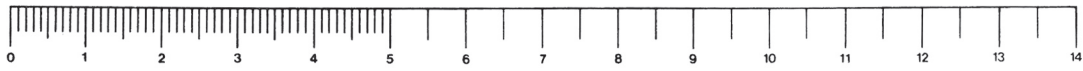

## 1ST BAG

<p><b>NUT DADO 01</b></p> <p>2 x 1 x 1,4mm.</p> <p>■ Qty. 18</p>	<p><b>SCREW VITE 04</b></p> <p>8,8mm. 1,4mm.</p> <p>■ Qty. 8</p>	<p><b>SCREW VITE 05</b></p> <p>10,7mm. 1,4mm.</p> <p>■ Qty. 14</p>	<p><b>SCREW VITE 06</b></p> <p>12,7mm. 1,4mm.</p> <p>■ Qty. 2</p>	<p><b>SCREW VITE 12</b></p> <p>5,7mm. 1,4mm.</p> <p>■ Qty. 1</p>
--	--	--	---	--

## 2ND BAG

<p><b>SCREW VITE 11</b></p> <p>4,7mm. 1,4mm.</p> <p>■ Qty. 16</p>	<p><b>SCREW VITE 14</b></p> <p>8,7mm. 1,4mm.</p> <p>■ Qty. 24</p>	<p><b>METAL BAR BARRA DI METALLO</b></p> <p>2x est. 7,2mm. <math>\varnothing</math> 0,9mm.</p> <p>2x est. 5mm. <math>\varnothing</math> 0,9mm.</p>	<p><b>SILICON GRAY TUBE</b> est. 140mm.</p> <p><b>BLACK TUBE</b> est. 450mm.</p>
---	---	--	--

Le parti indicate con vanno incollate con colla Cianoacrilato. Fare molta attenzione a non incollare le parti non segnate.

Colla Cianoacrilato Use Chanoacrylate glue

Glue together the parts showed with and use Chanoacrylate glue. Pay attention, don't glue the parts not indicated.

## SUGGESTED COLORS

<p><b>A</b></p> <p><b>GLOSS BLACK</b> F.S. 17038 Italeri AcrylicPaint - 4695AP</p>	<p><b>B</b></p> <p><b>GLOSS RED</b> F.S. 11302 Italeri AcrylicPaint - 4605AP</p>	<p><b>C</b></p> <p><b>METAL FLAT ALUMINUM</b> F.S. 37178 Italeri AcrylicPaint - 4677AP</p>	<p><b>D</b></p> <p><b>FLAT GUN METAL</b> F.S. 37200 Italeri AcrylicPaint - 4681AP</p>	<p><b>E</b></p> <p><b>FLAT MEDIUM BROWN</b> F.S. 30111 Italeri AcrylicPaint - 4306AP</p>	<p><b>F</b></p> <p><b>FLAT LEATHER</b> F.S. 30100 Italeri AcrylicPaint - 4674AP</p>
--	--	--	---	--	---

**1**

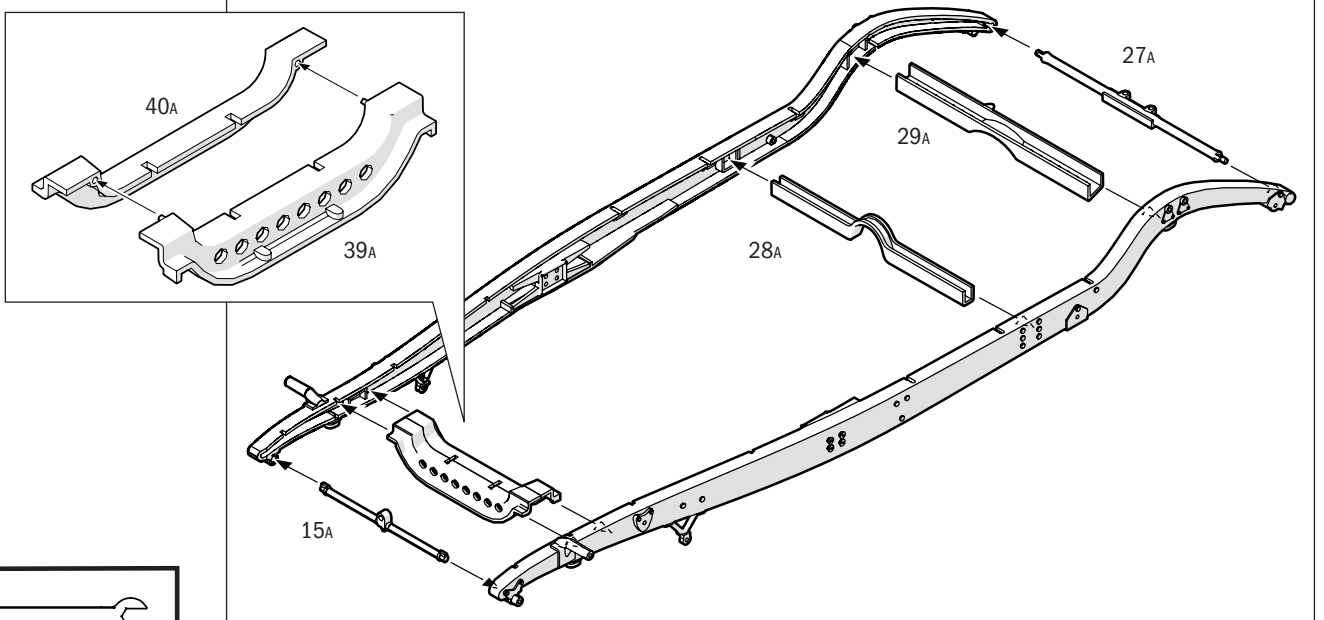

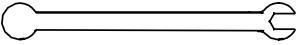
  
 Please use this wrench for NUT 01  
 Usare questa chiave inglese per il DADO 01

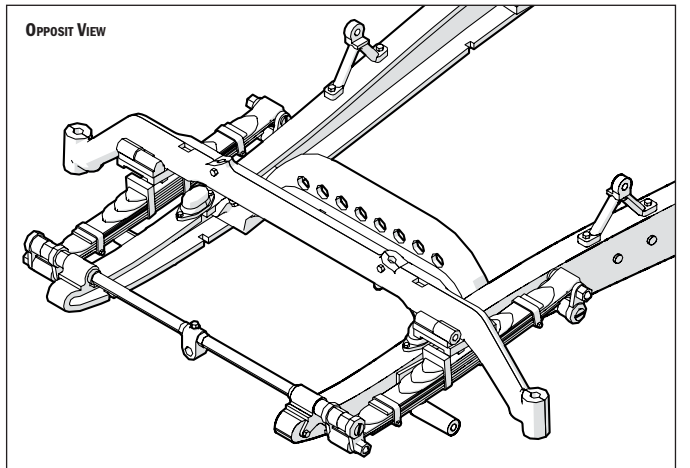
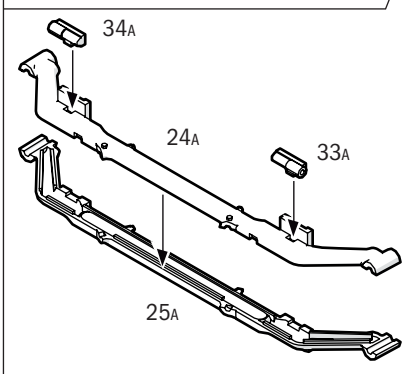
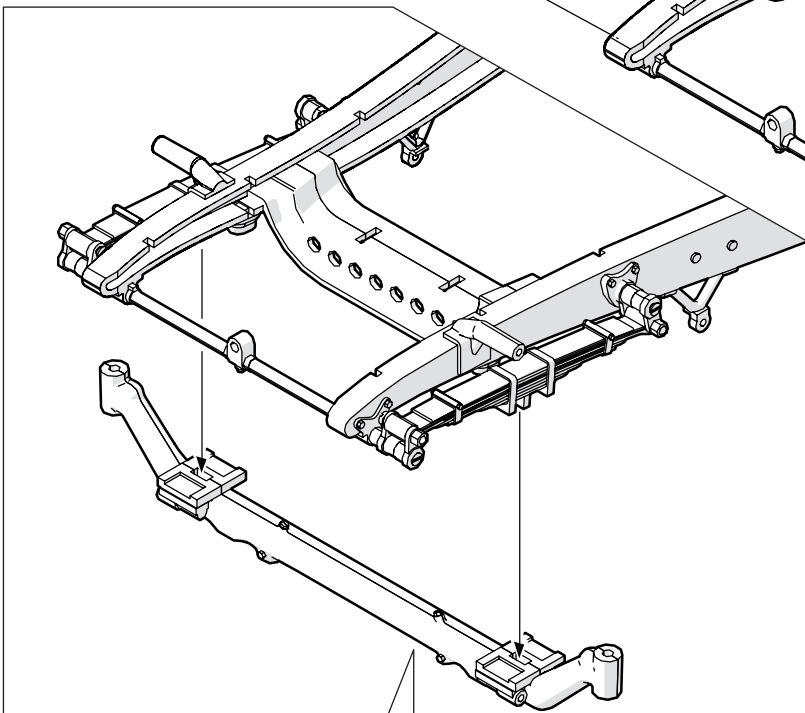
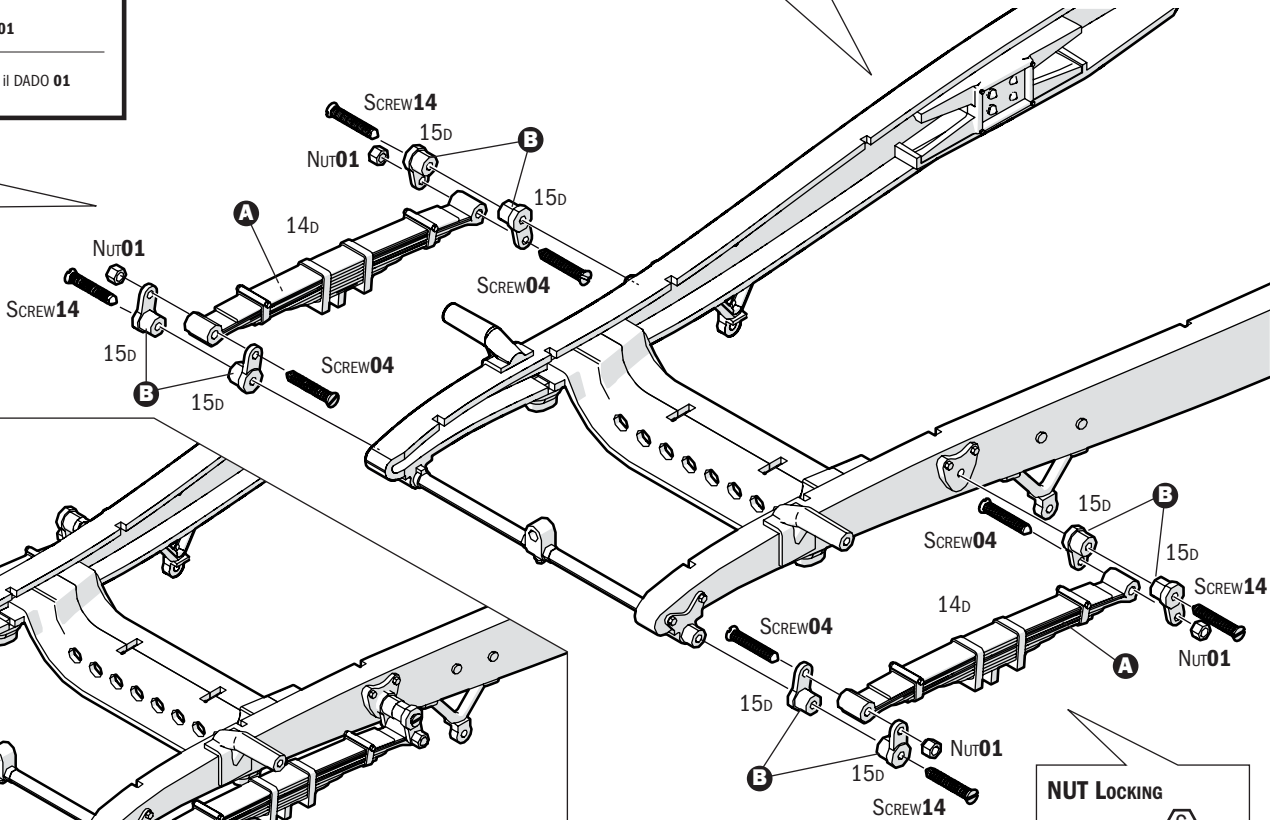
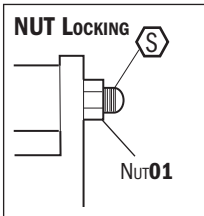

3

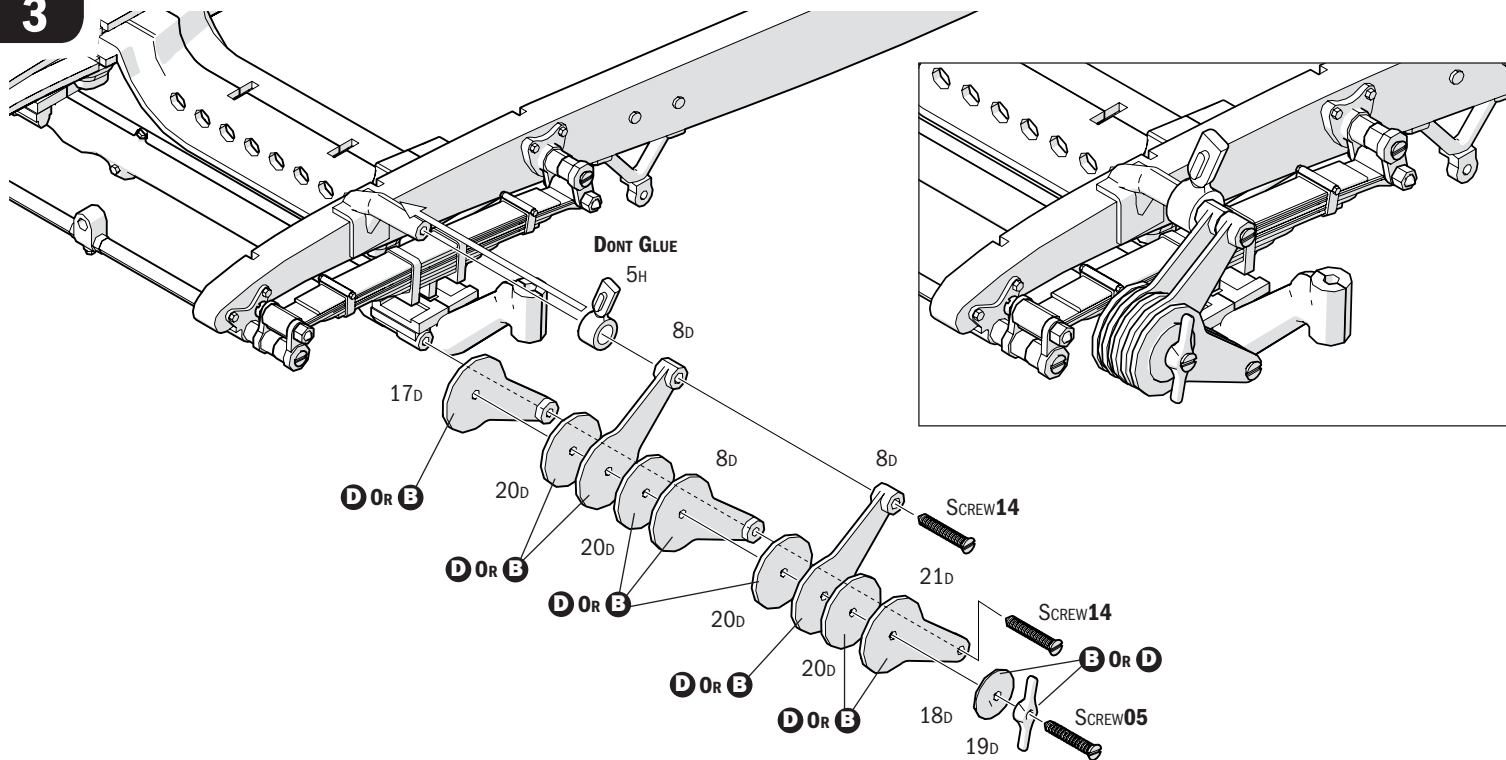

4

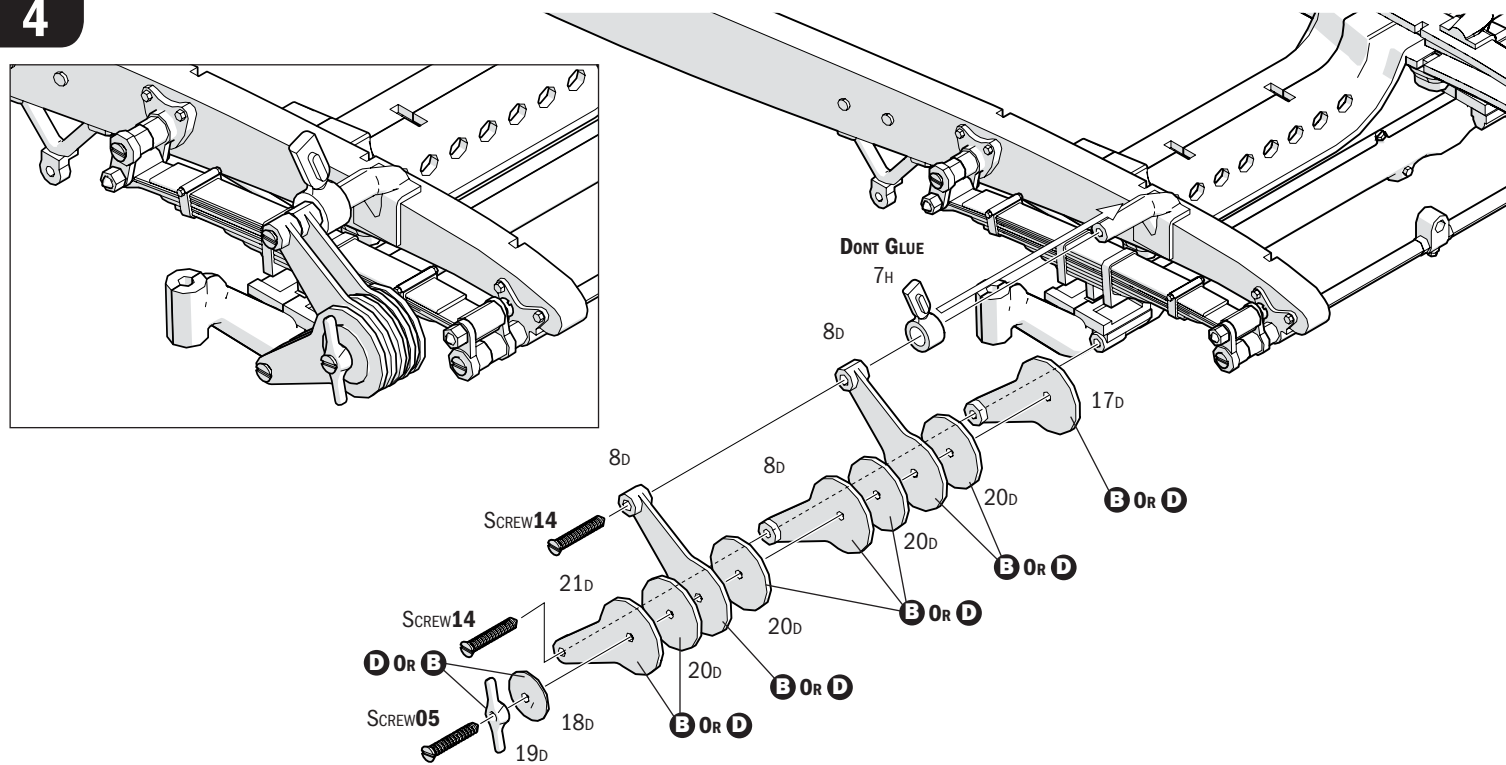

5

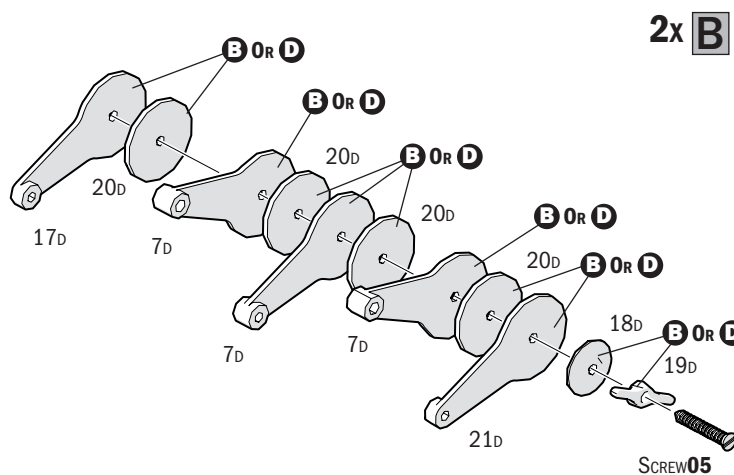
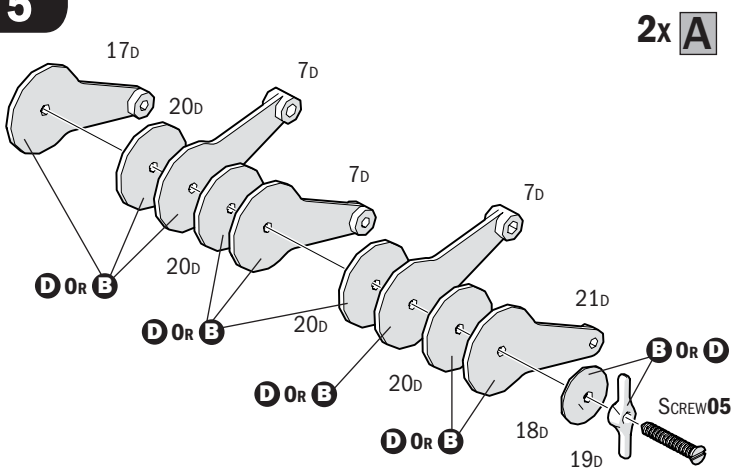

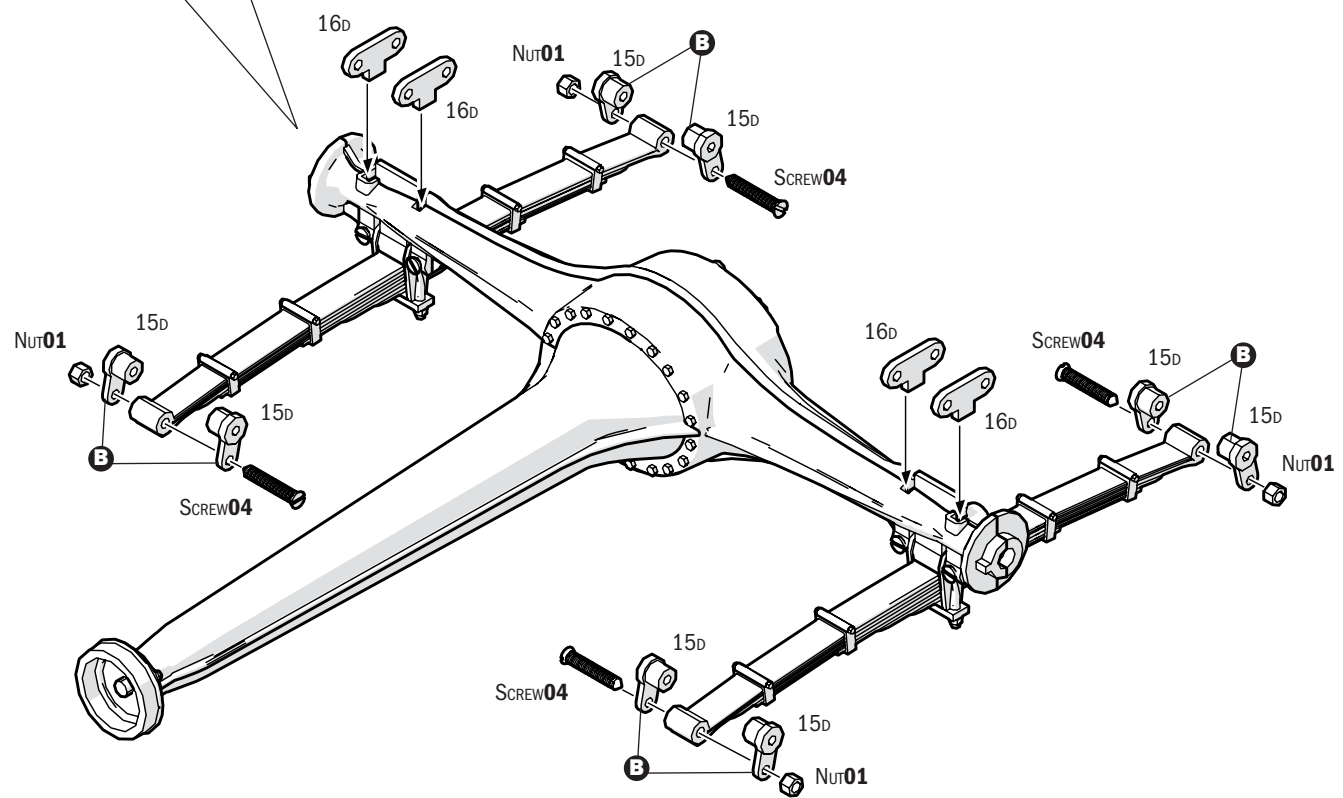
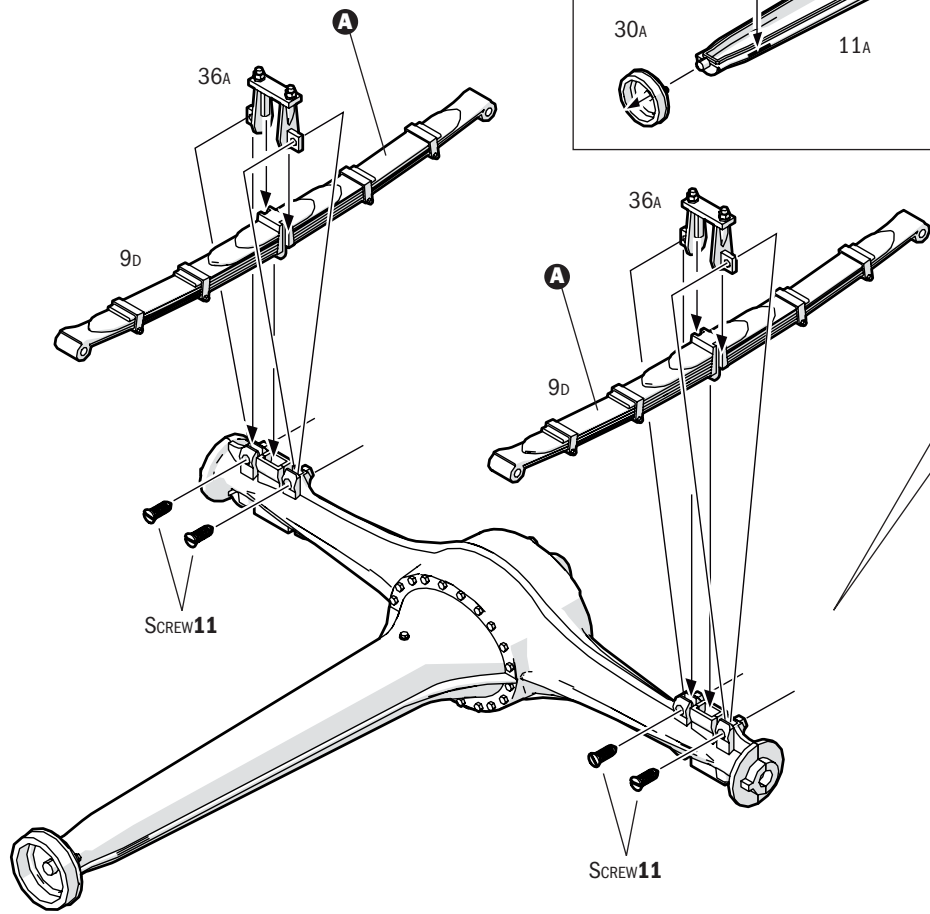
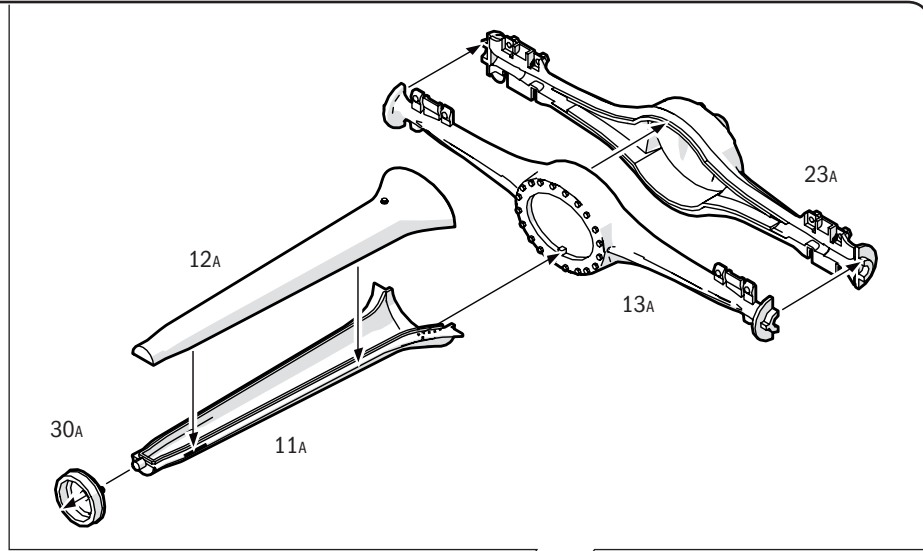

C

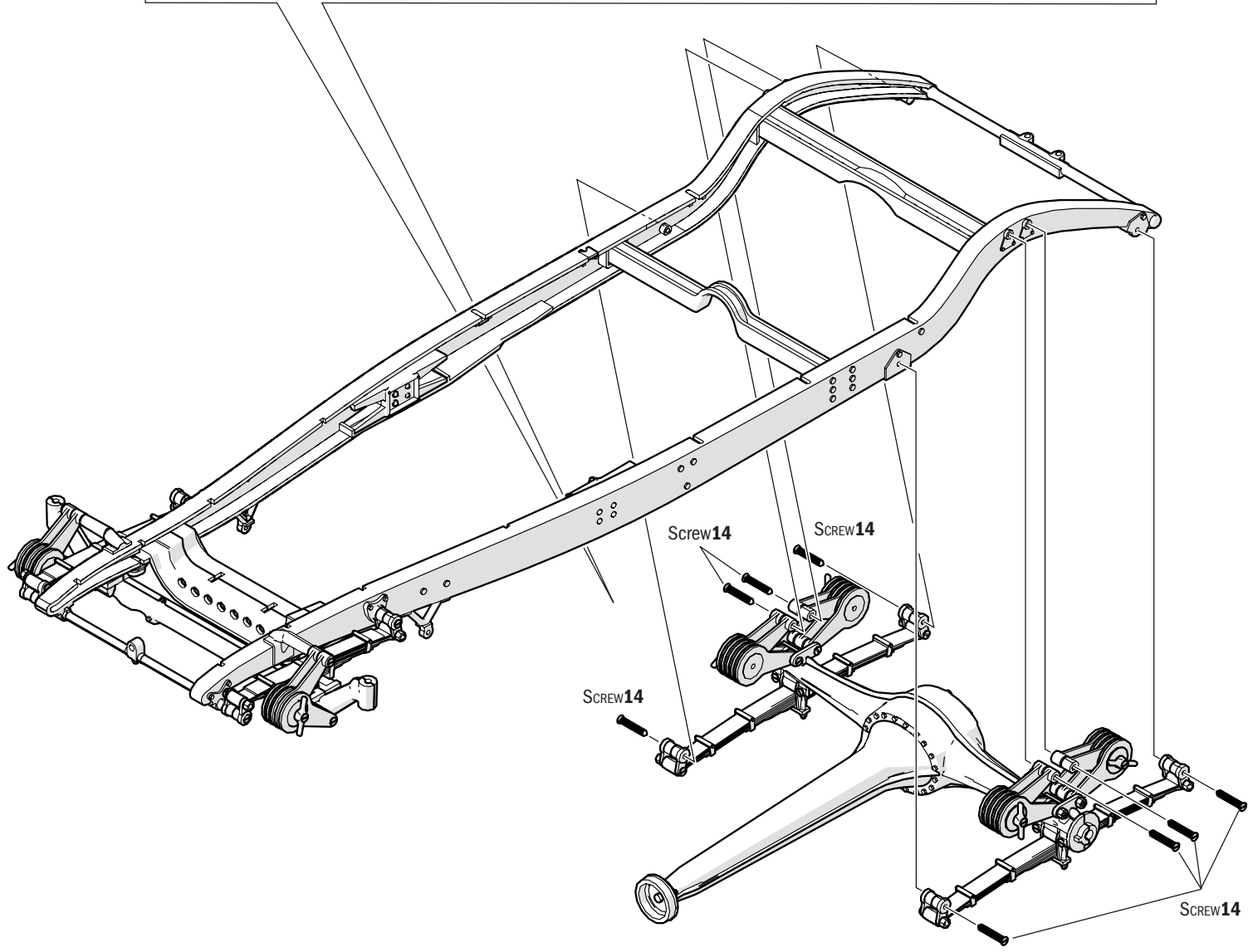
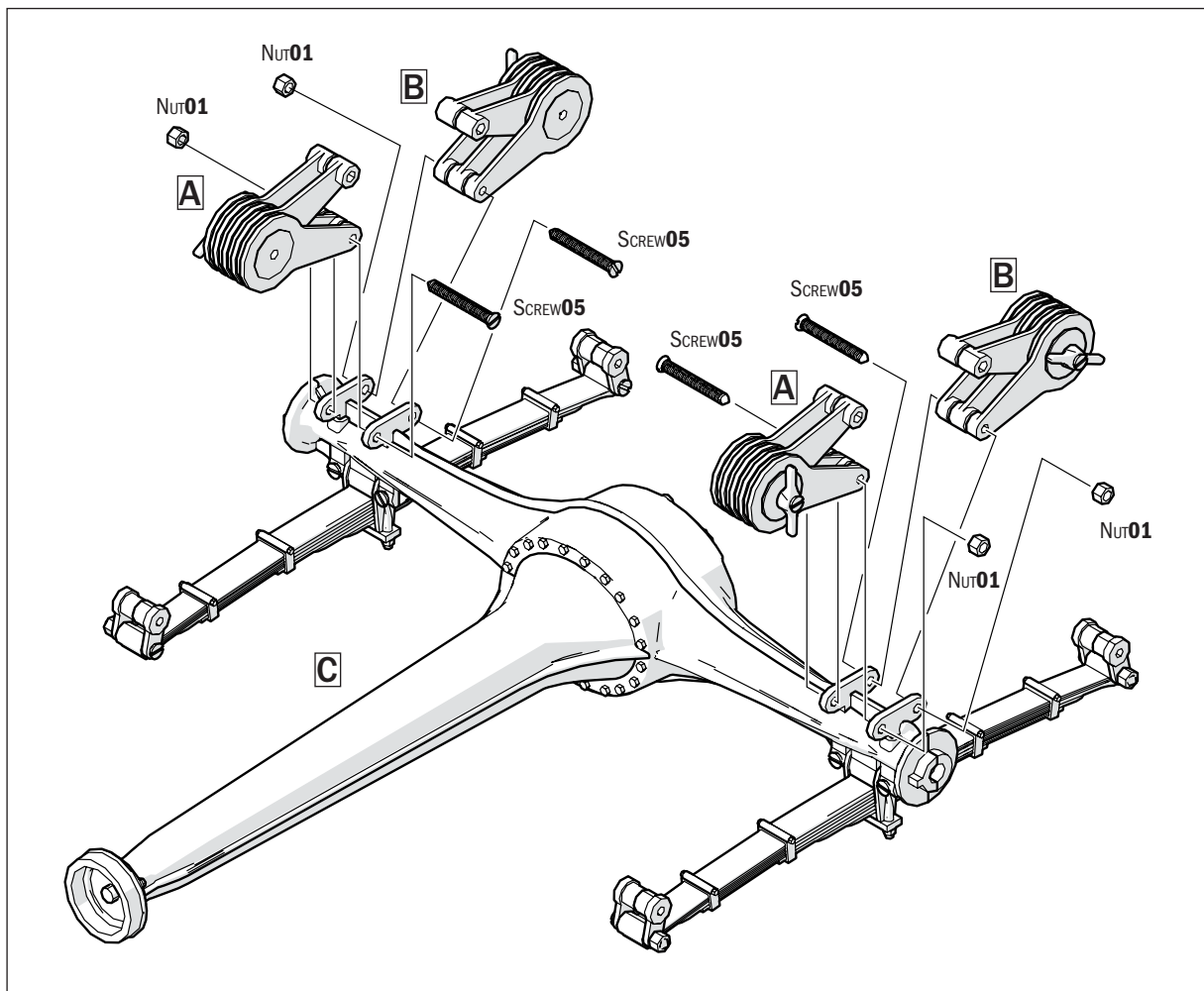



8

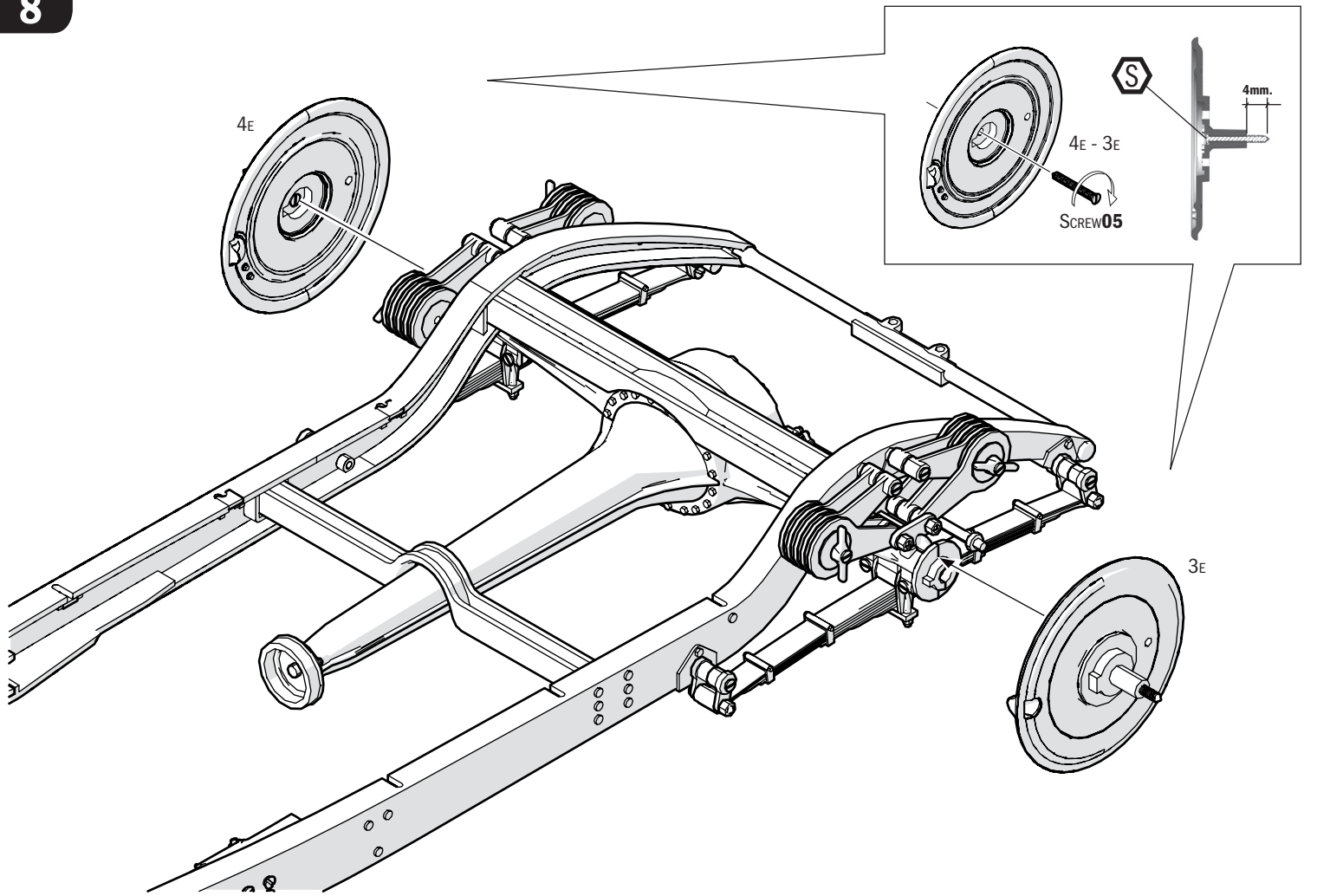

9

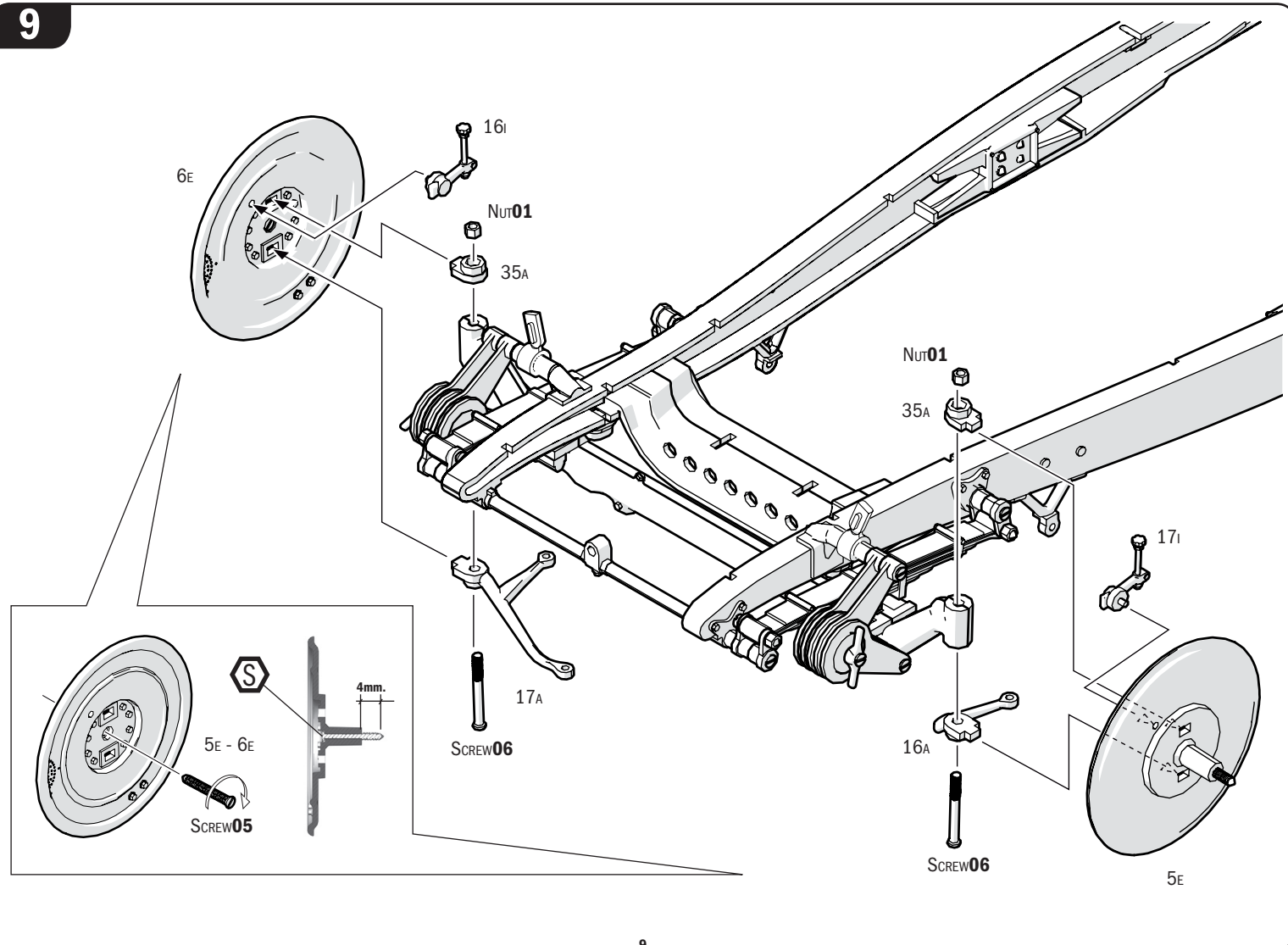

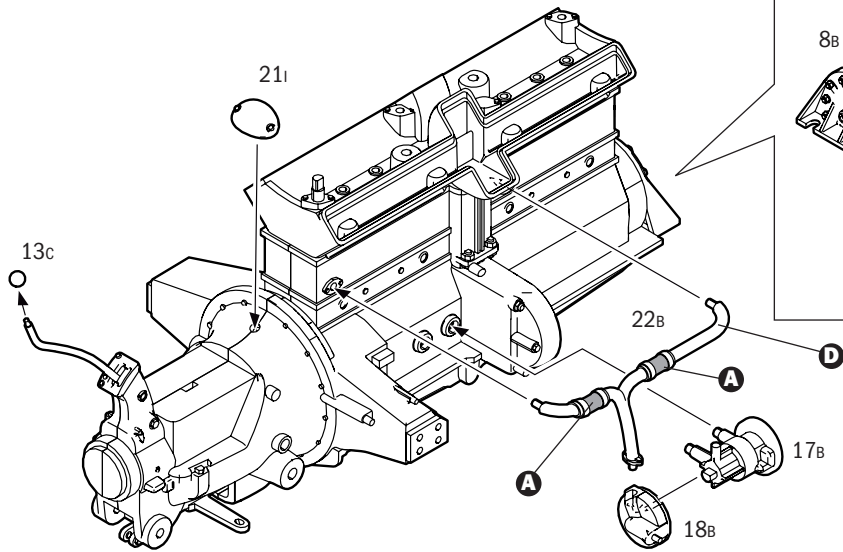
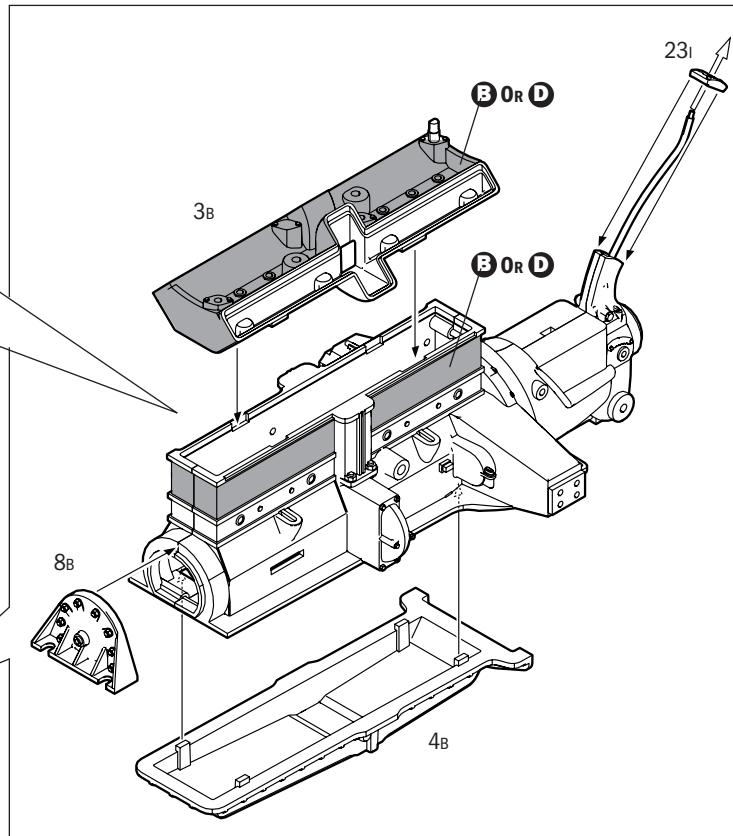
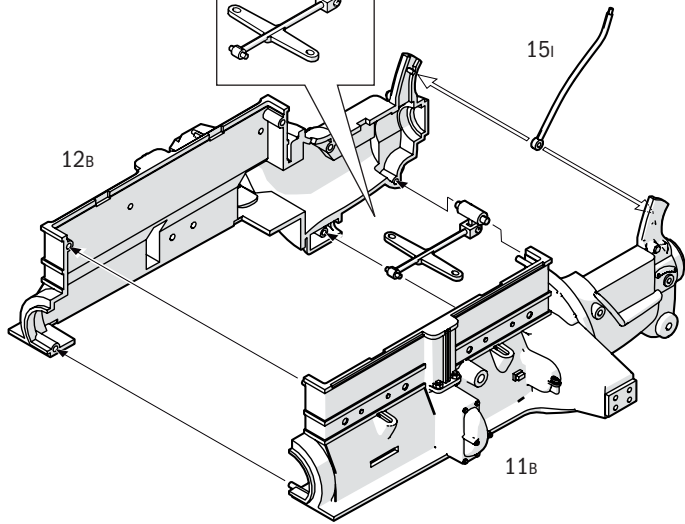
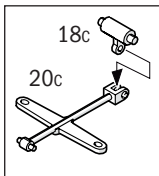

C

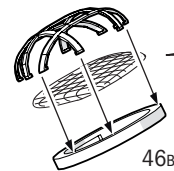
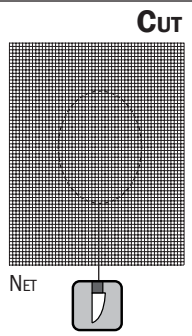
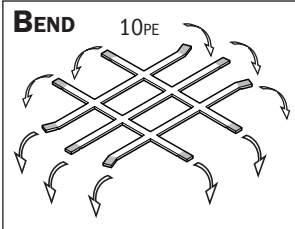
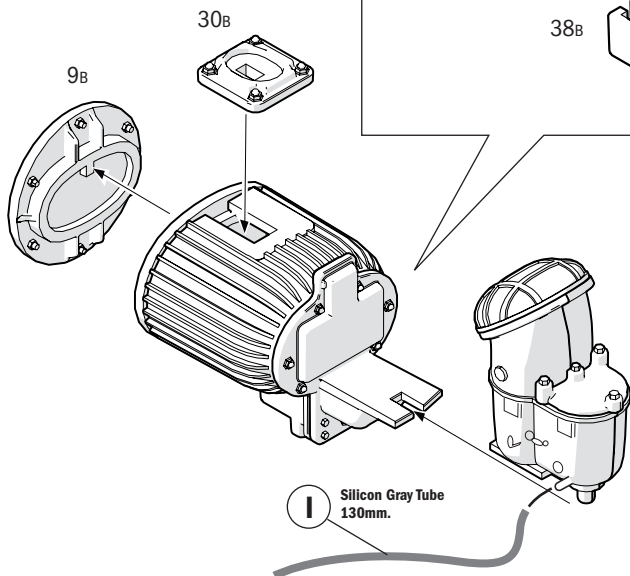
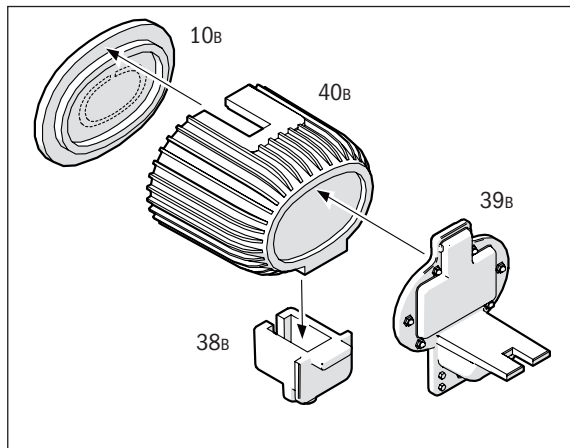

PE ALTERNATIVE

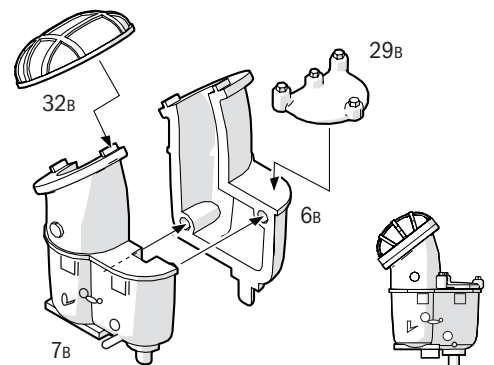

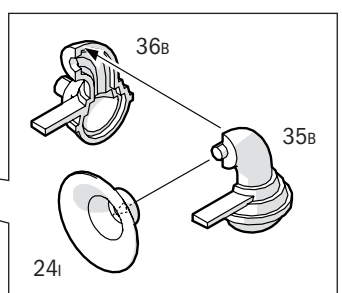
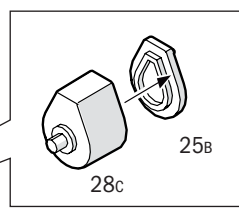
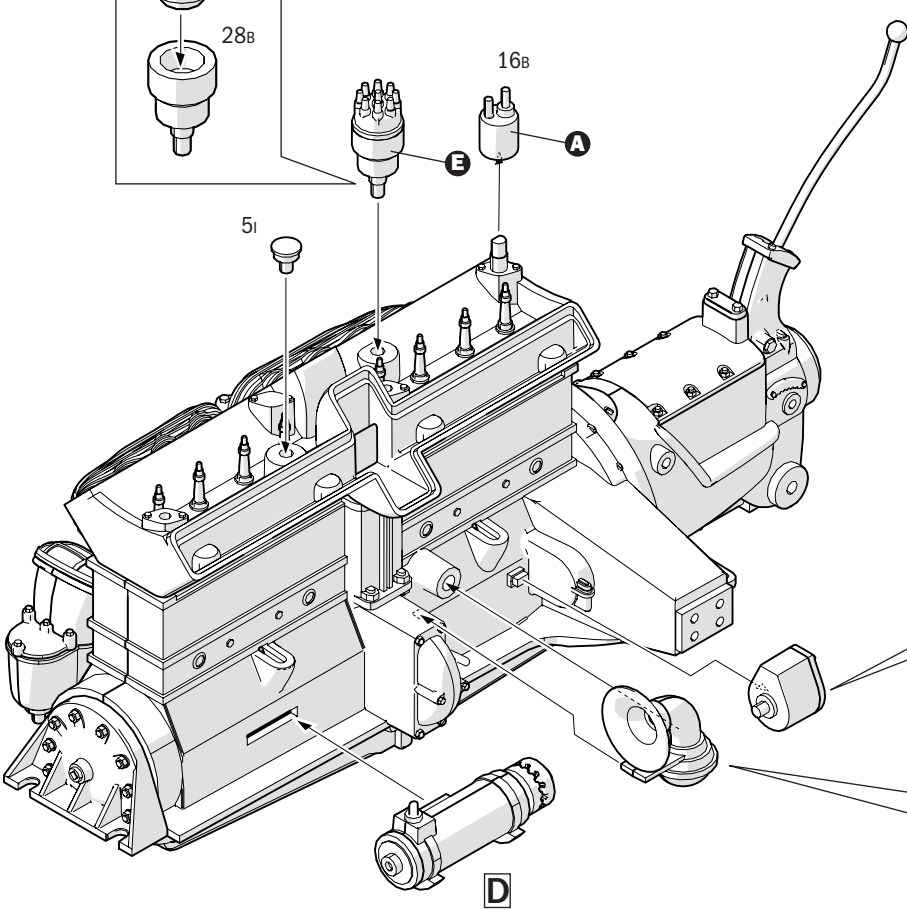
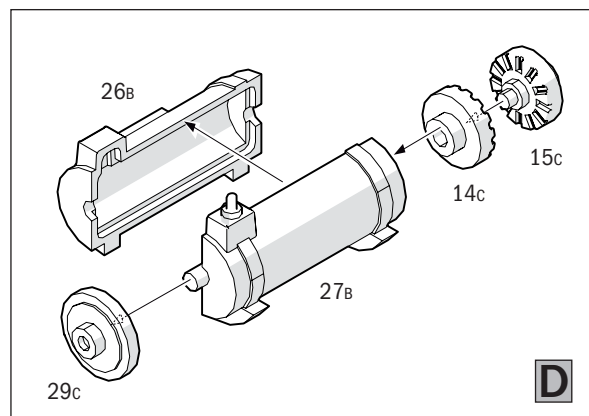
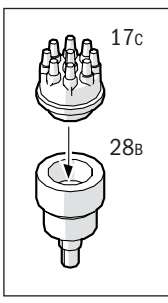
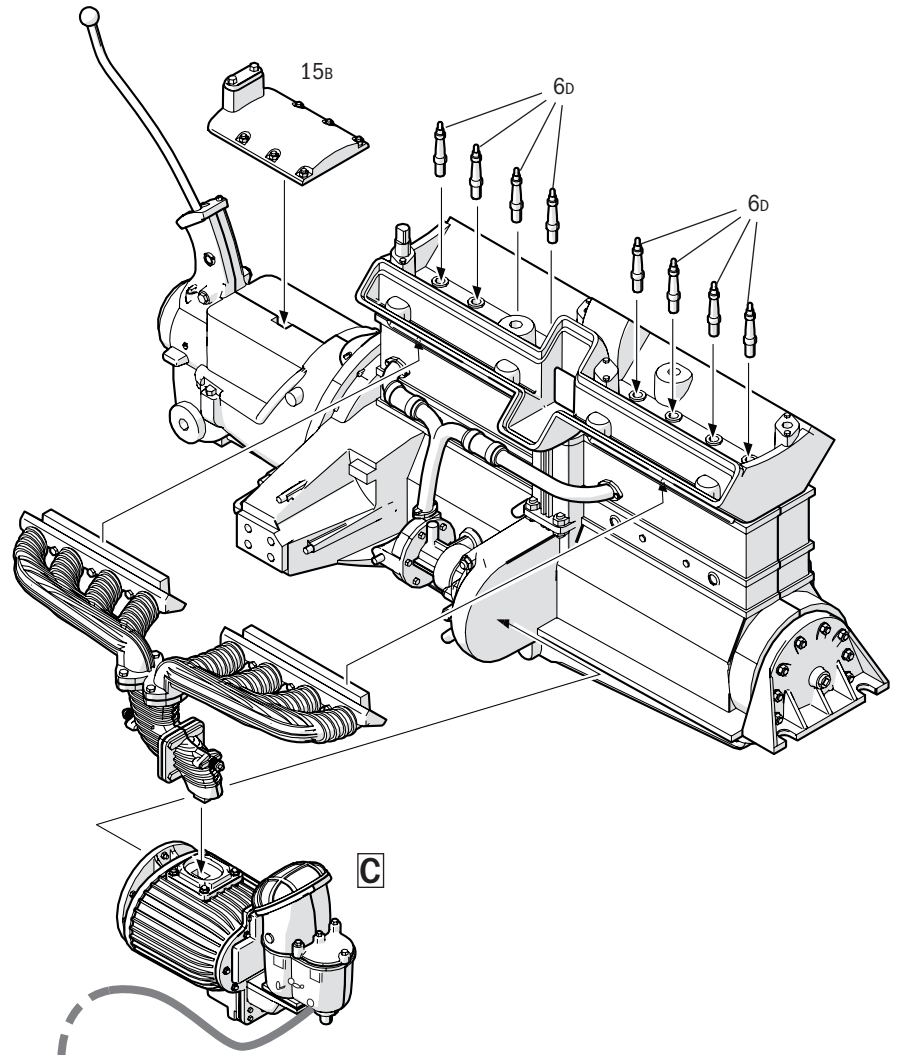
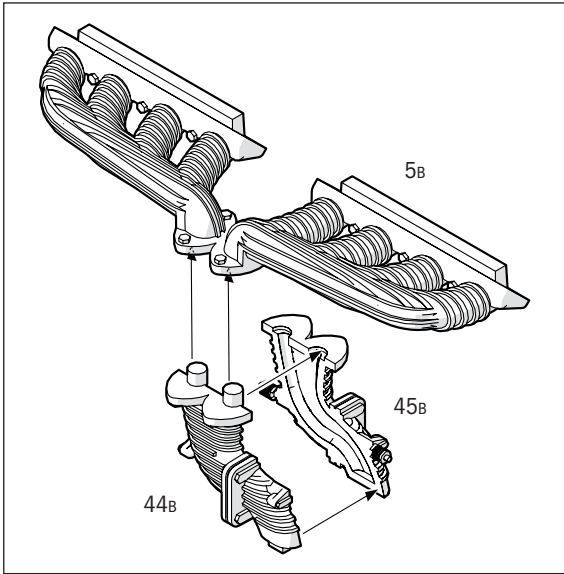

14

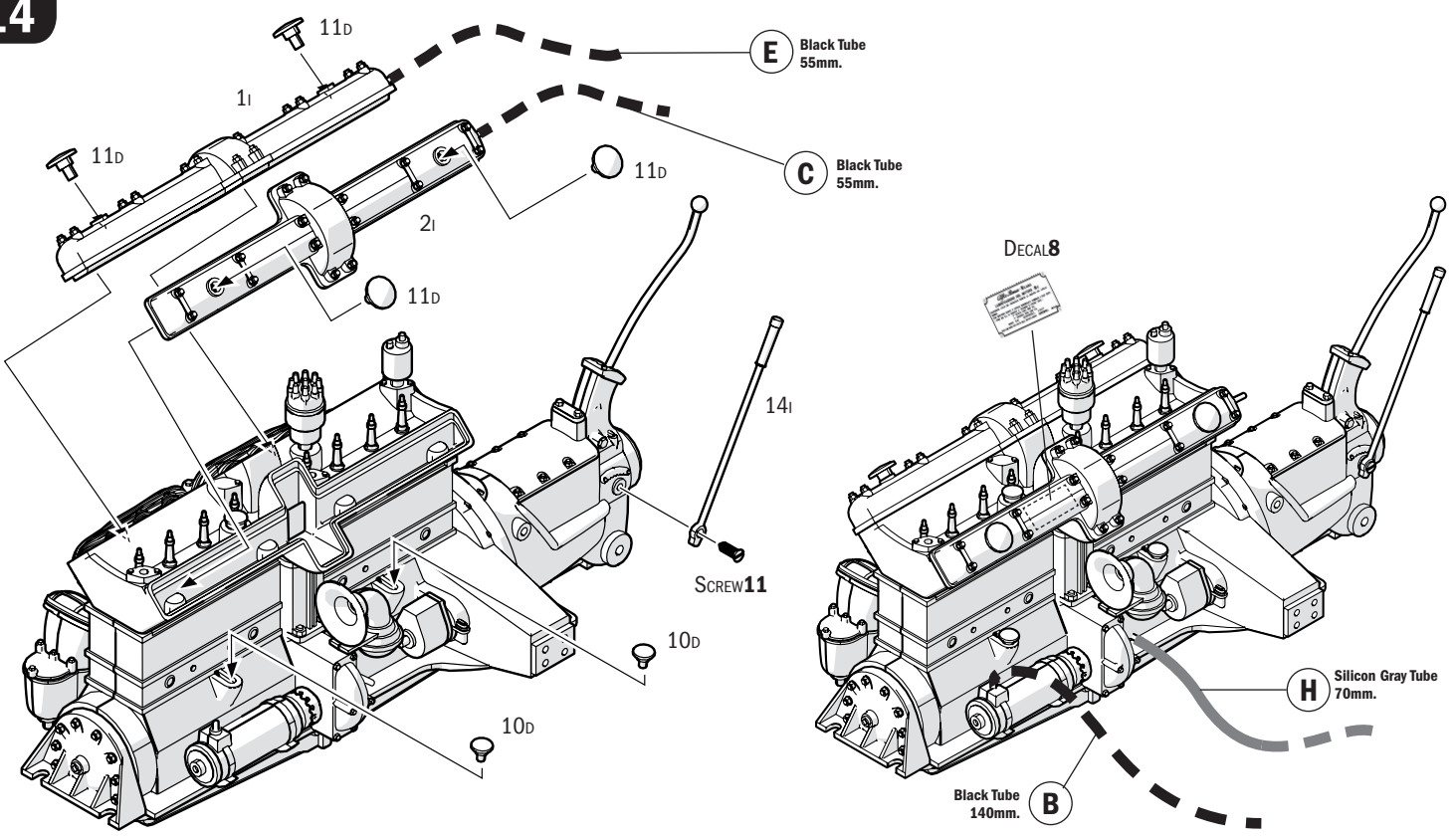

15

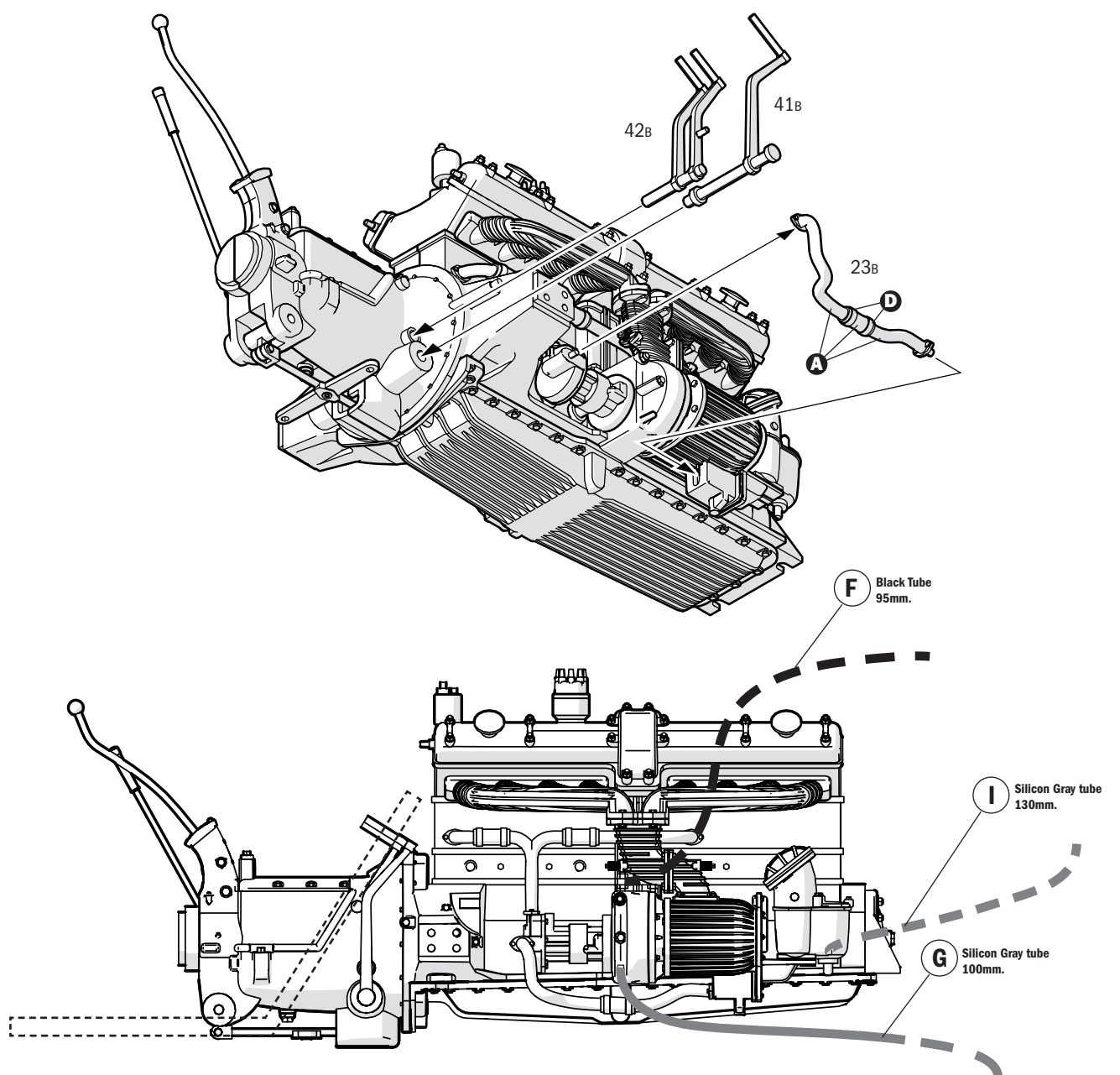

# 16

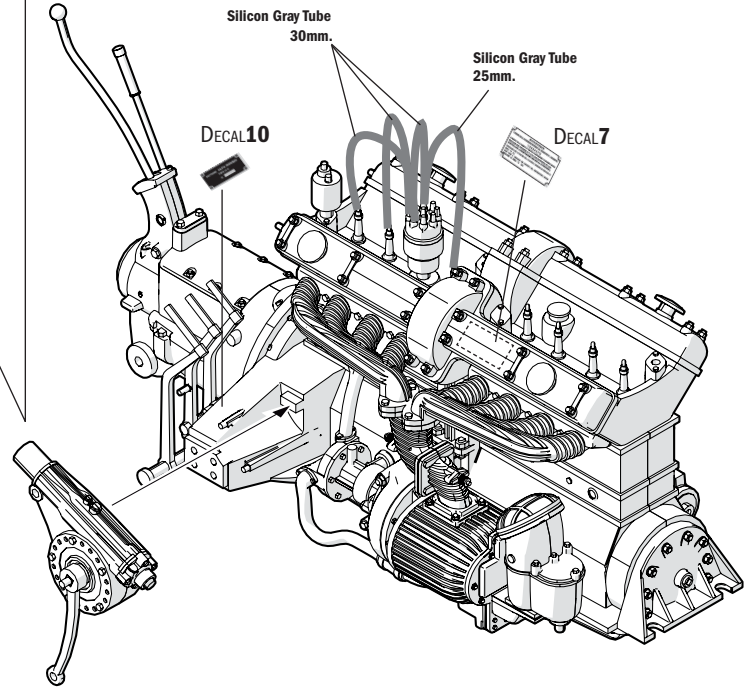
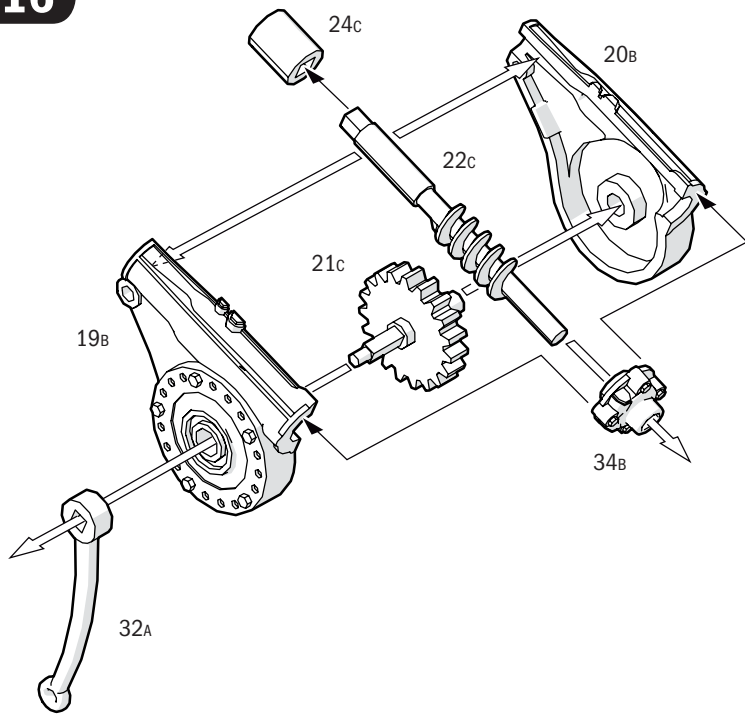

# 17

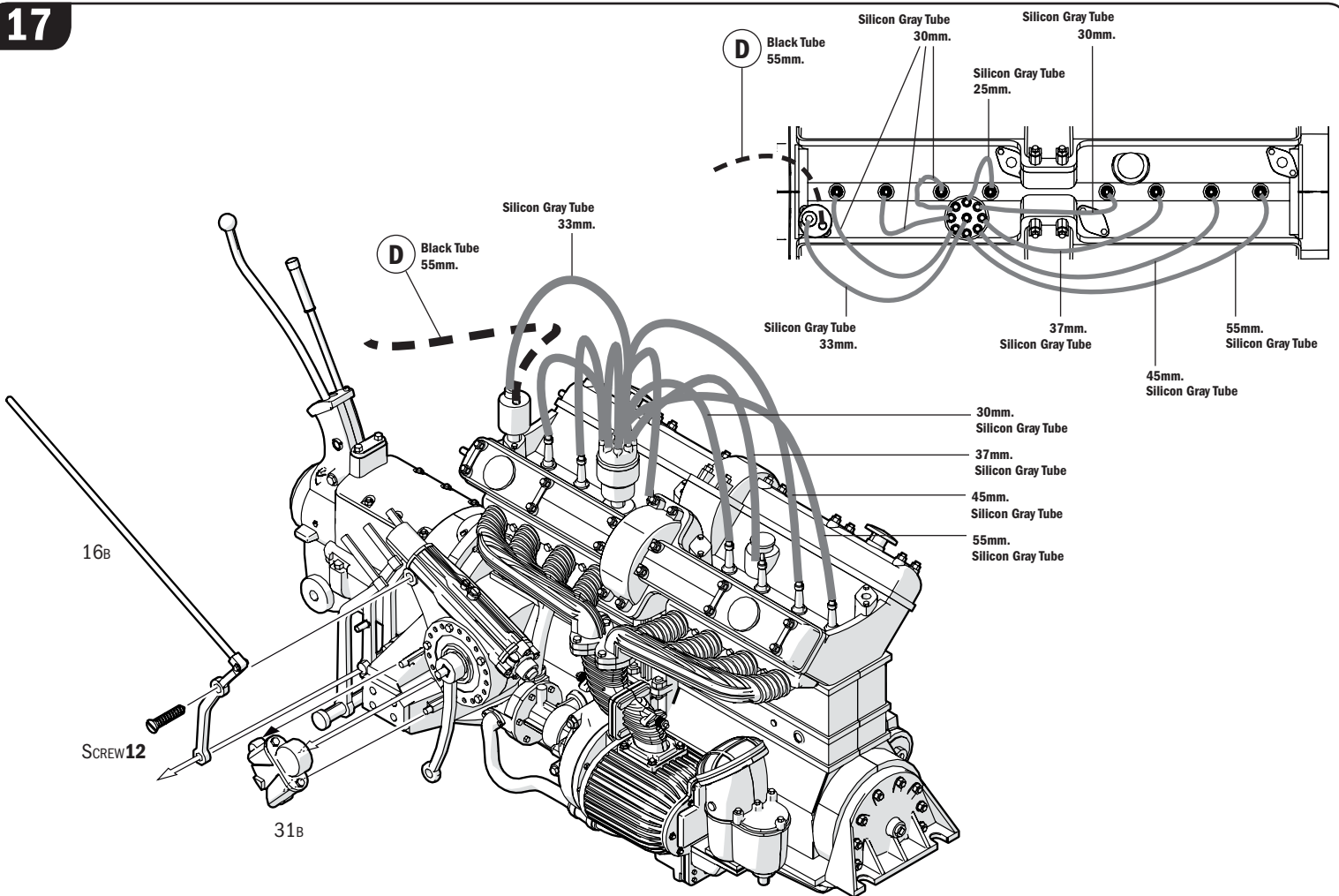

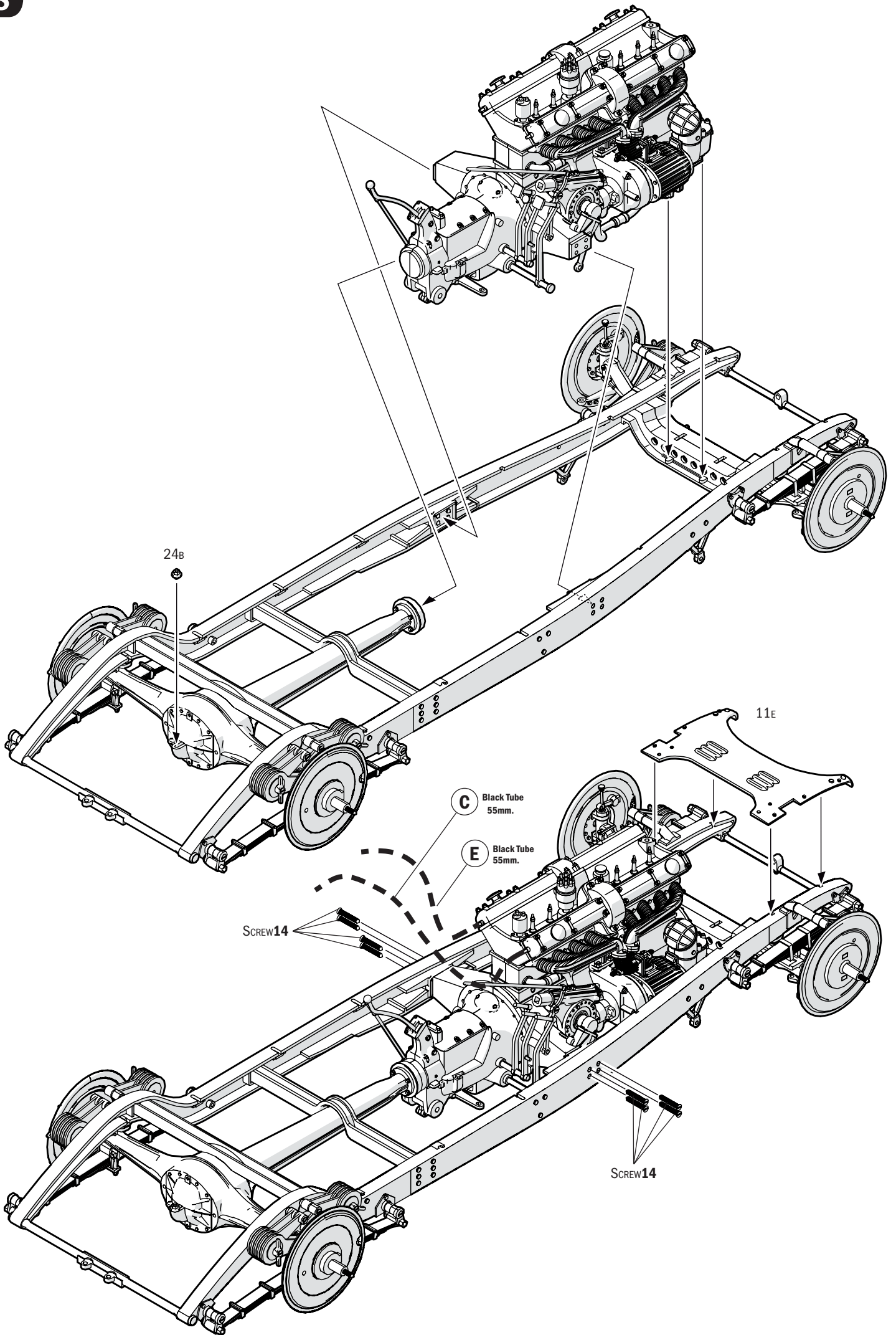

19

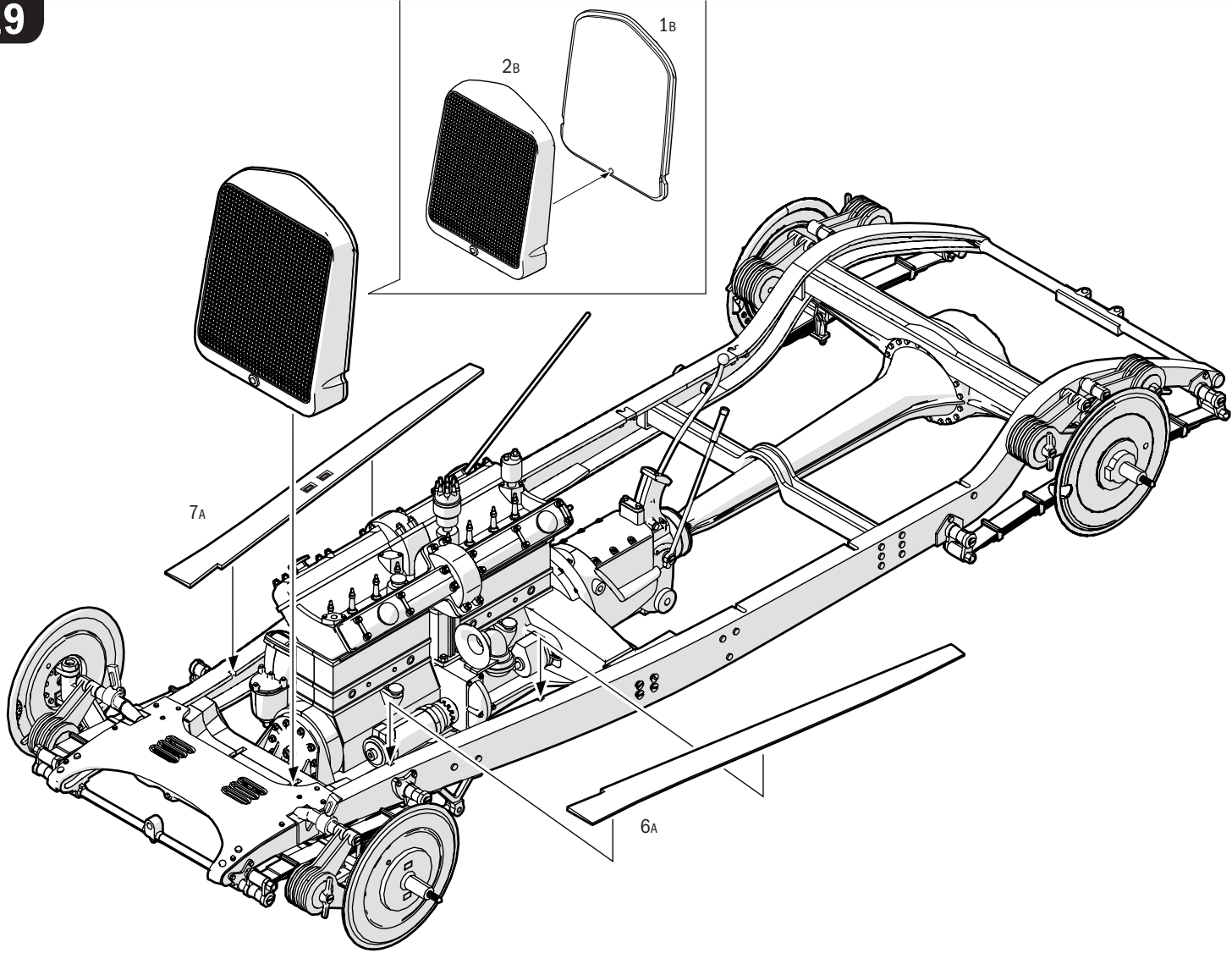

20

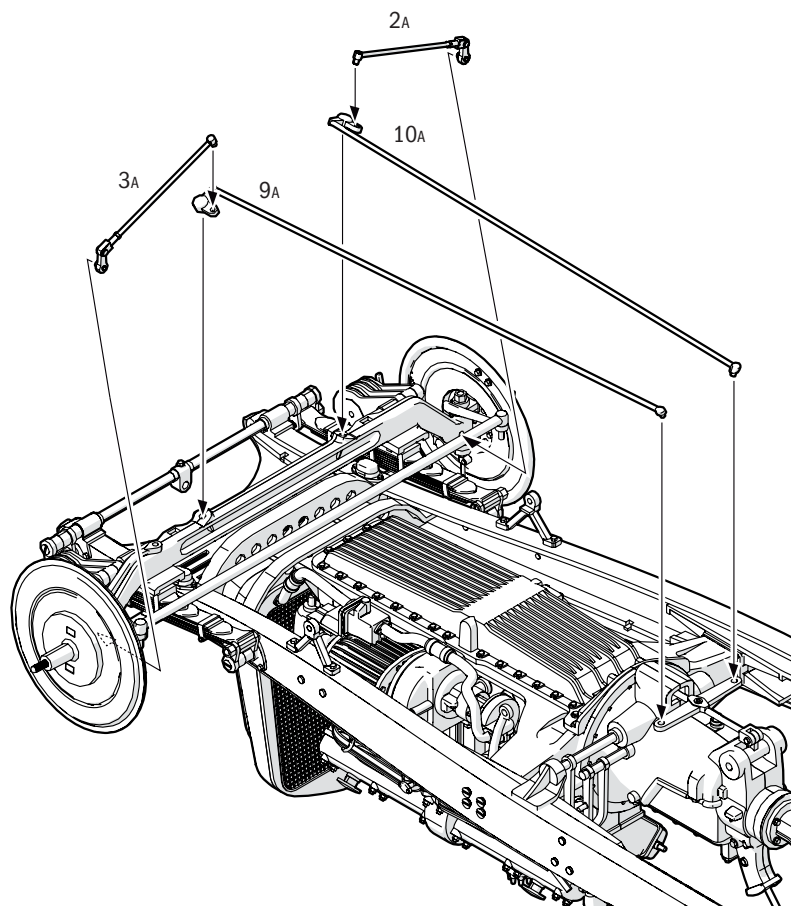
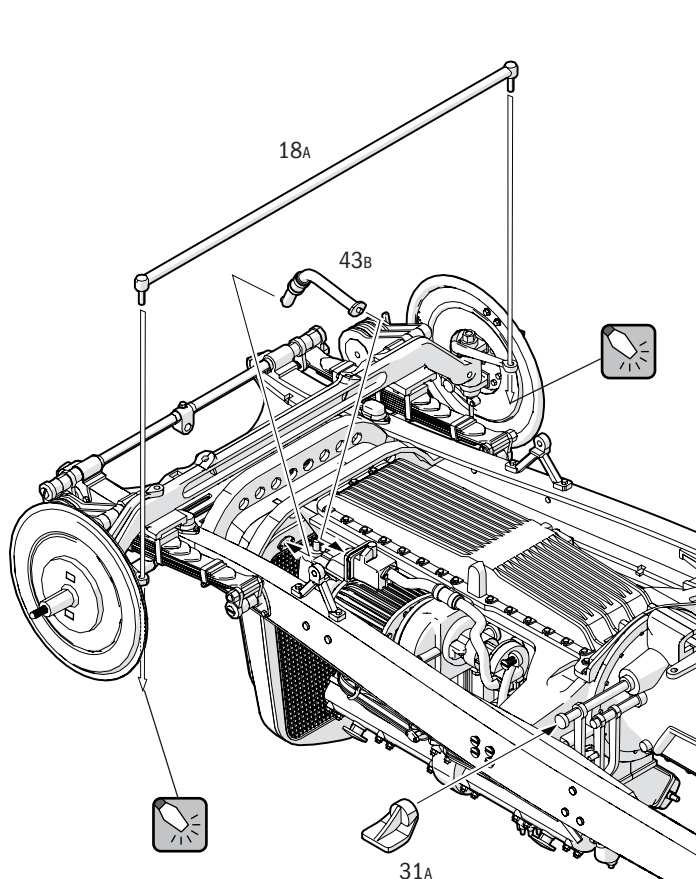

21

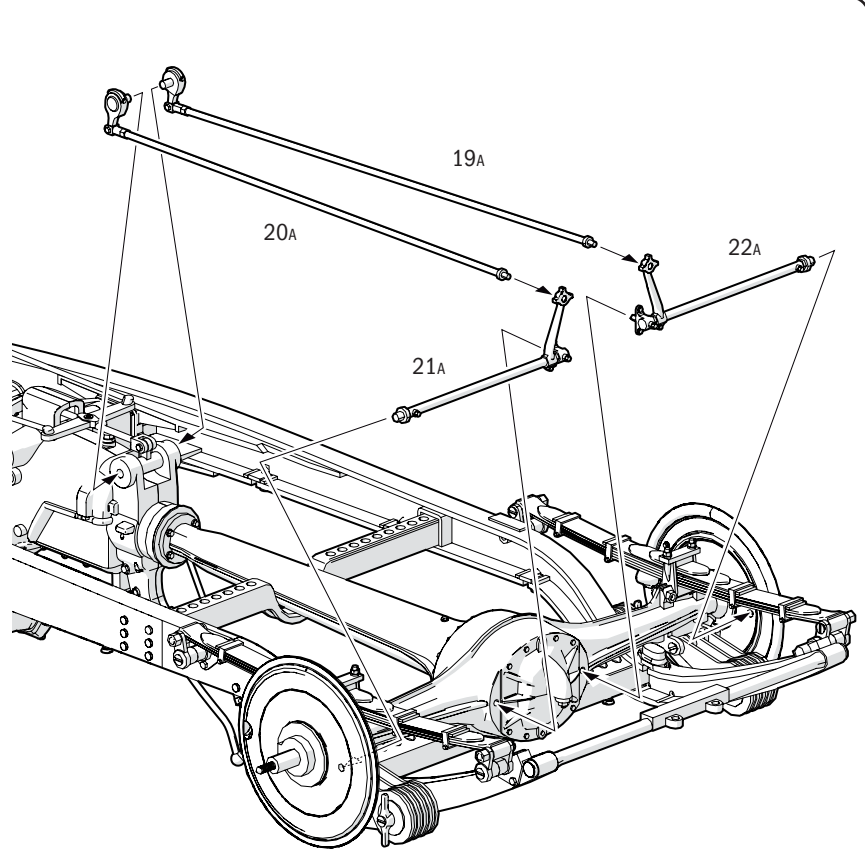
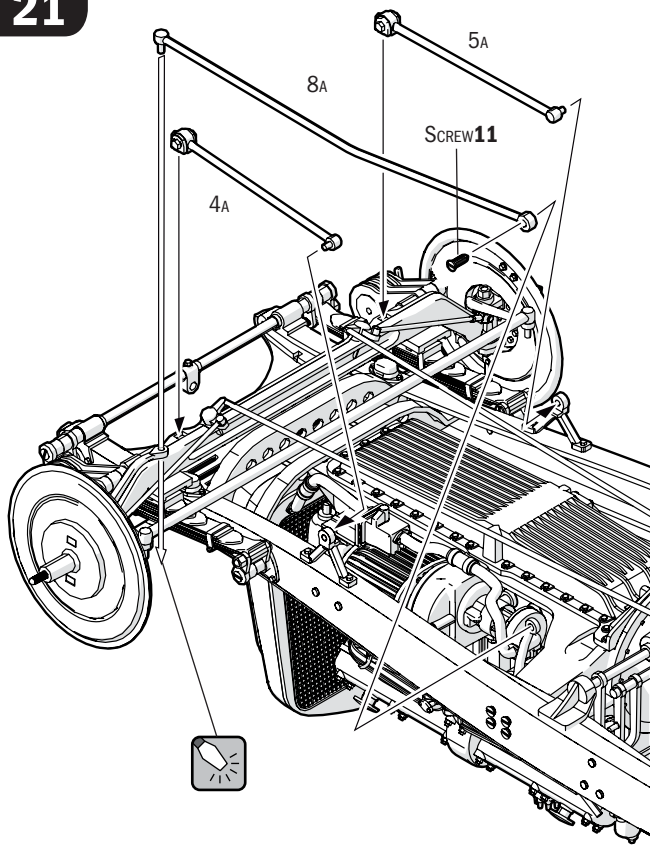

22

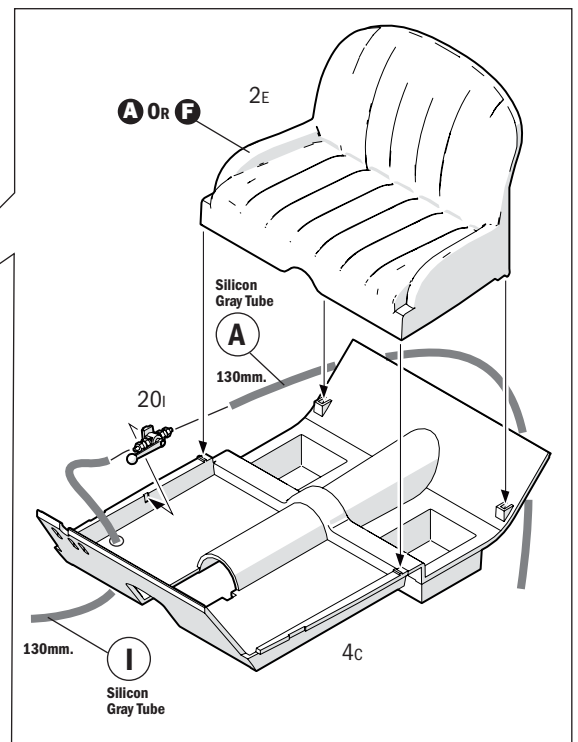
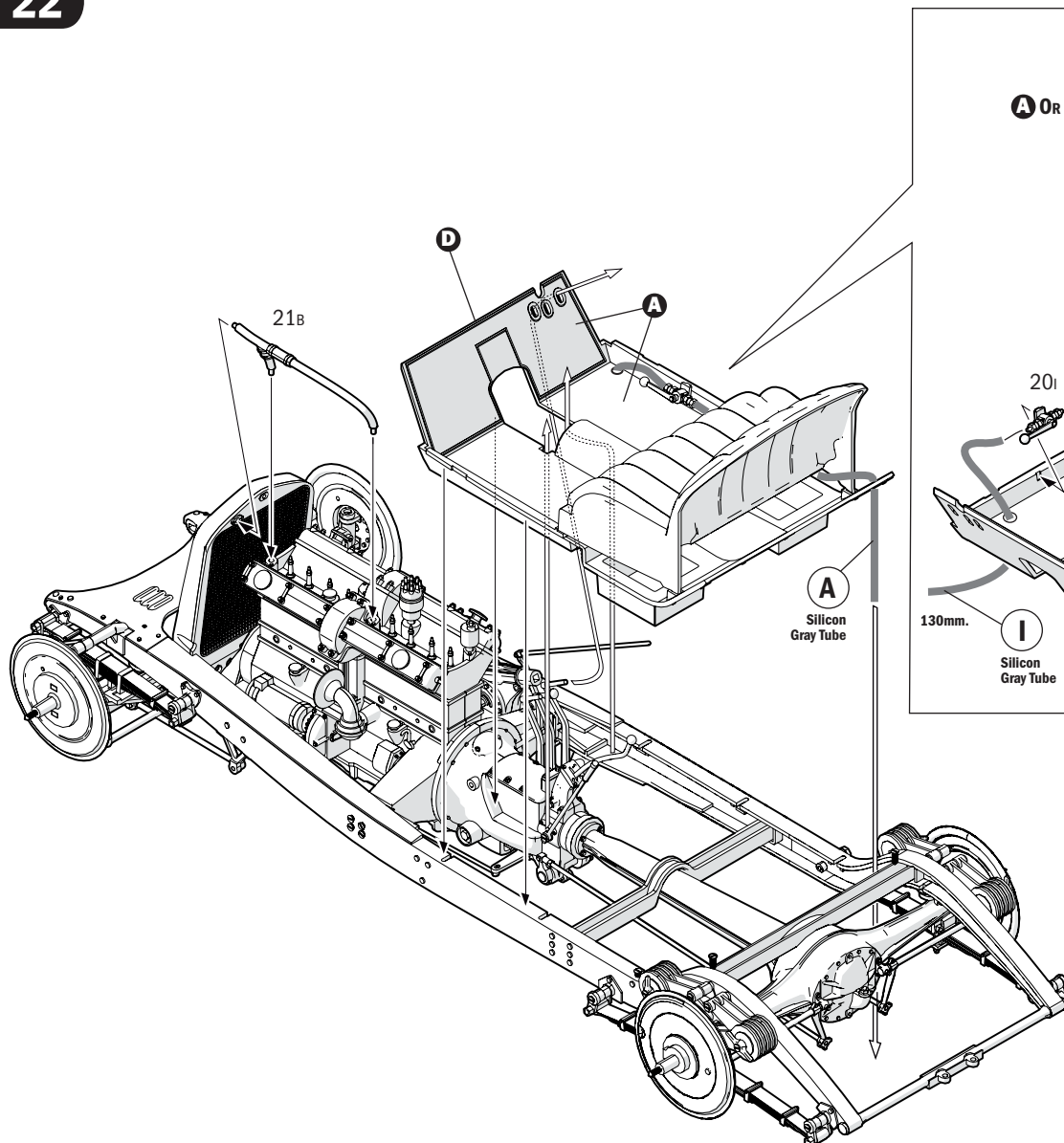



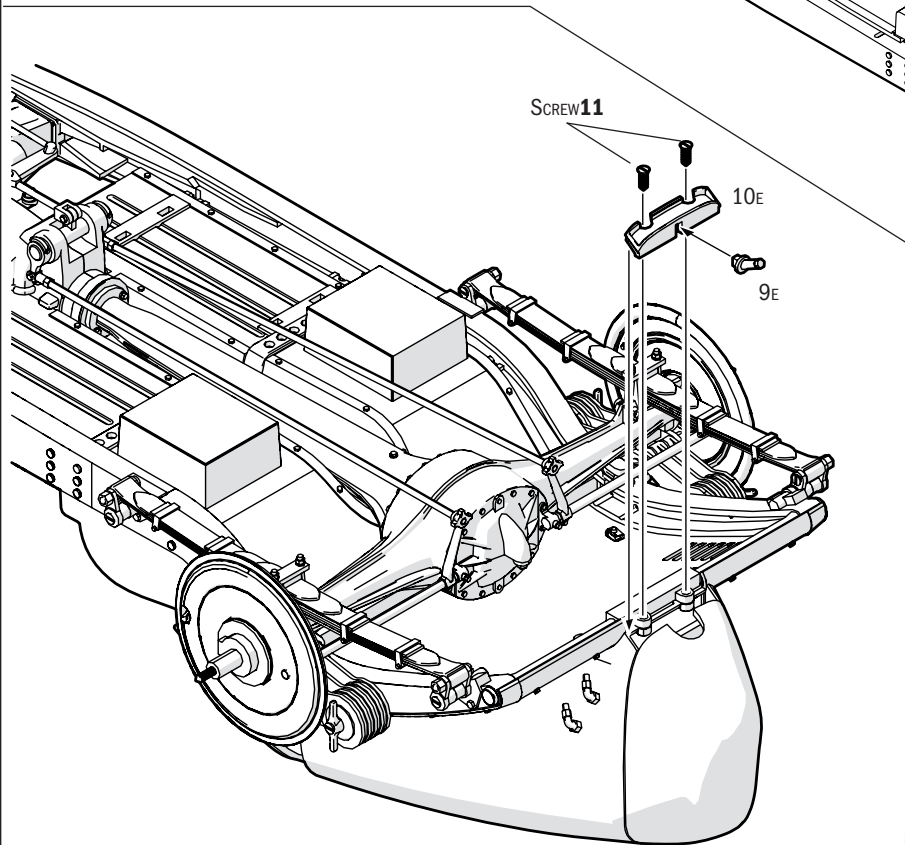
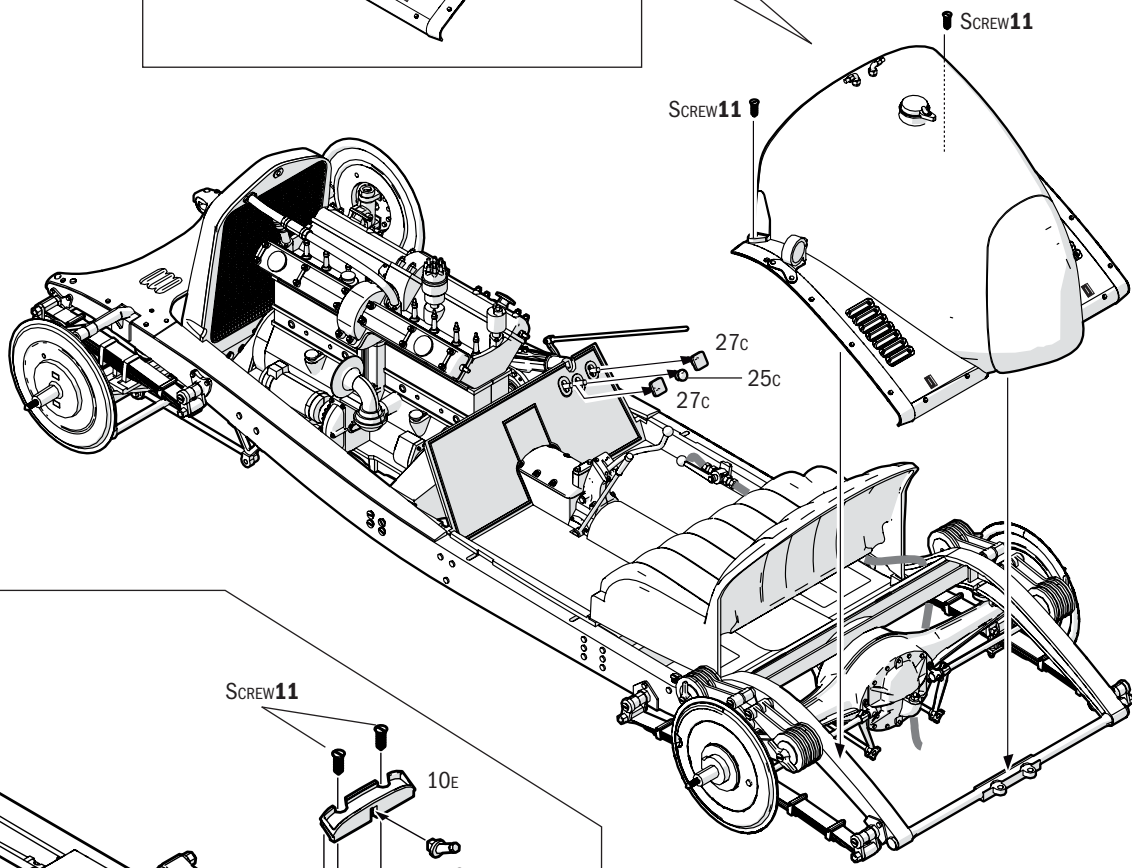
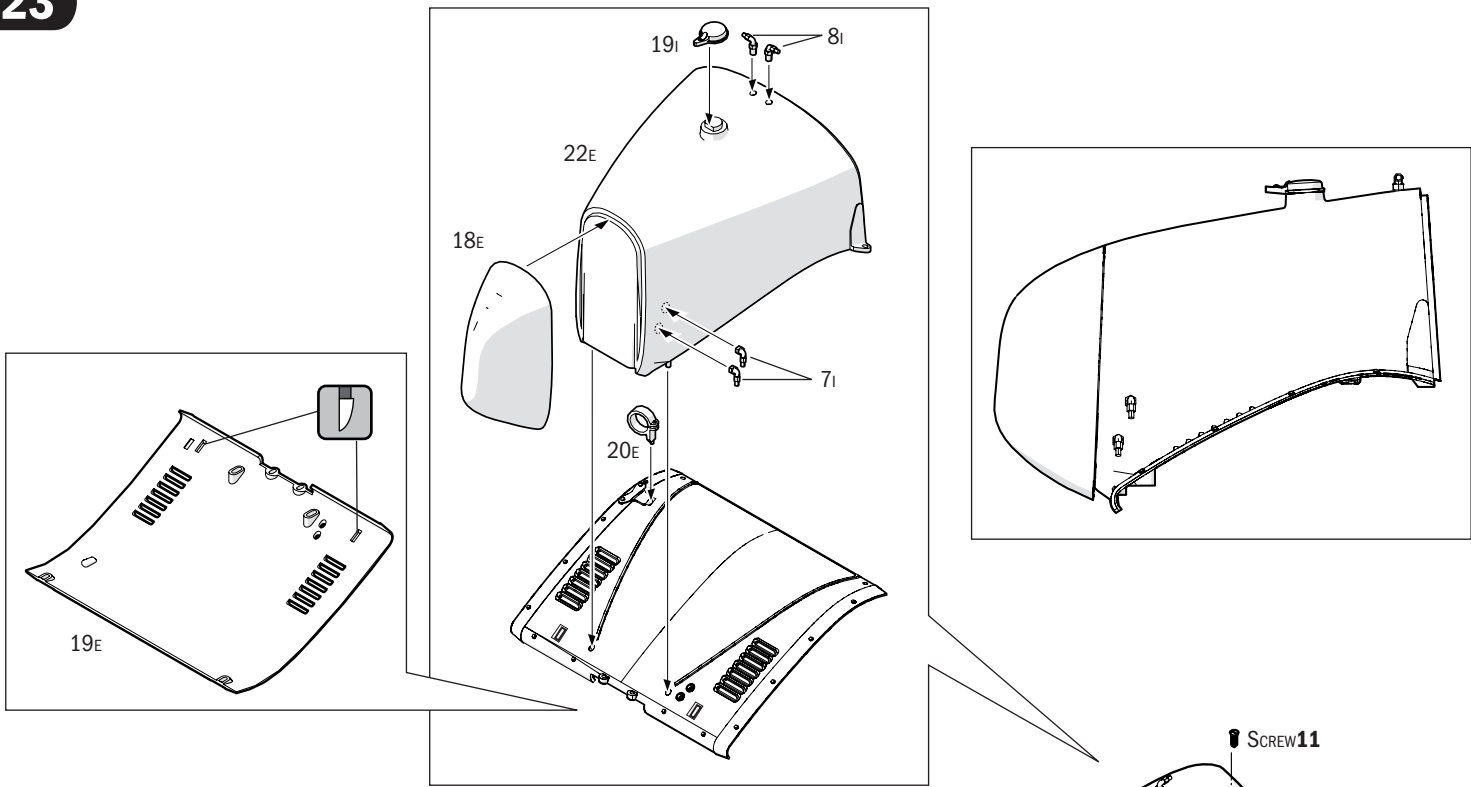

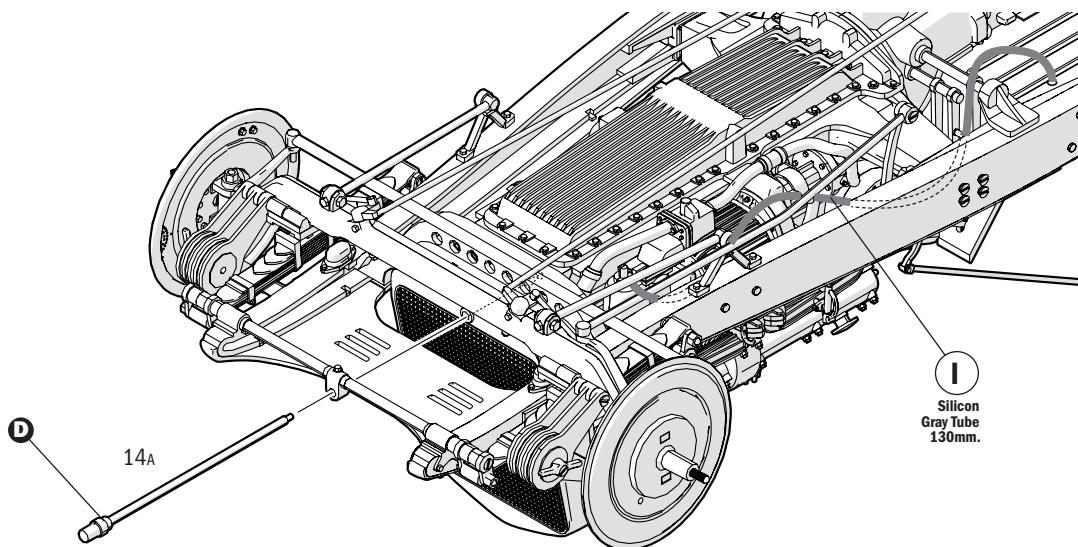
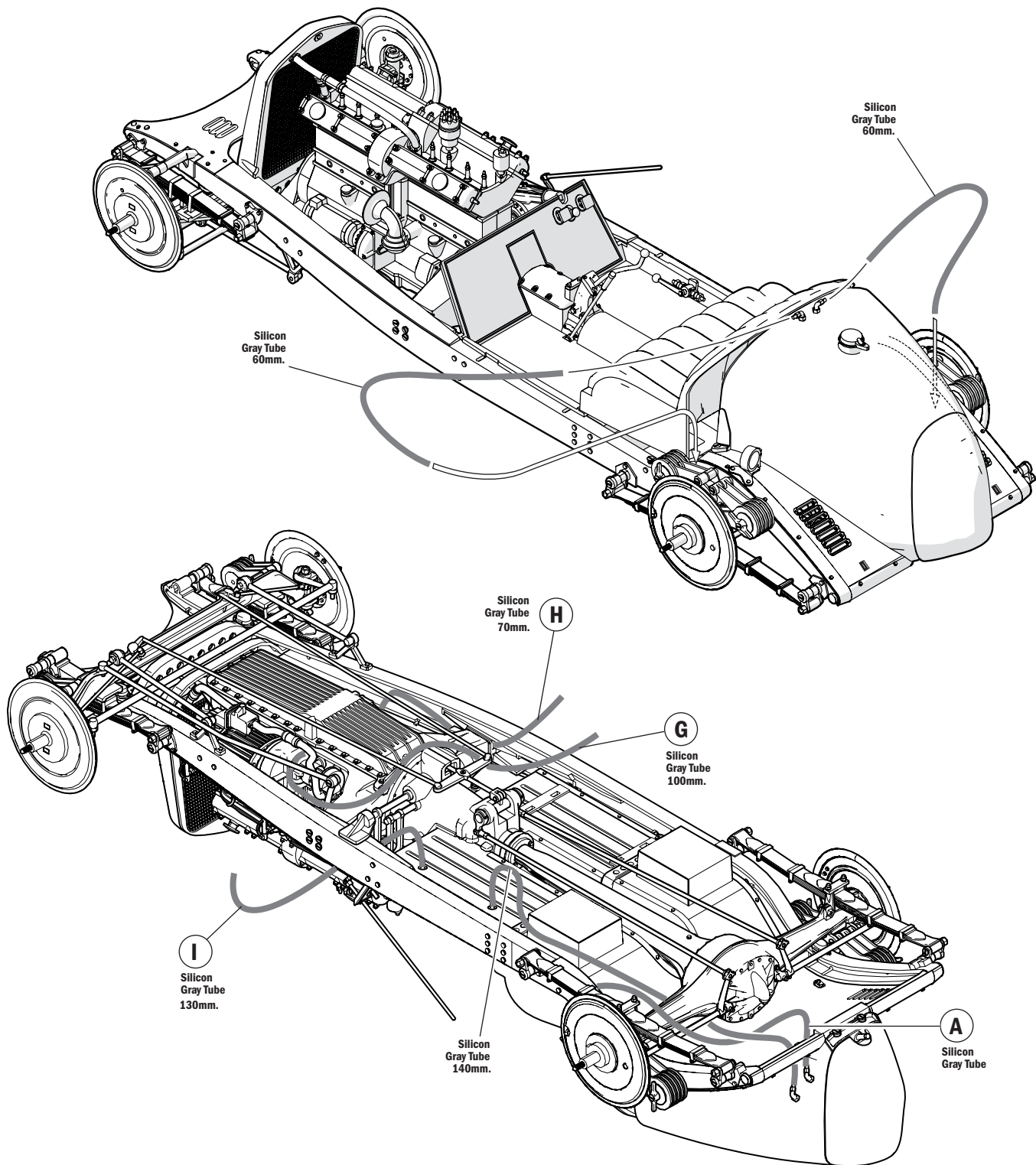

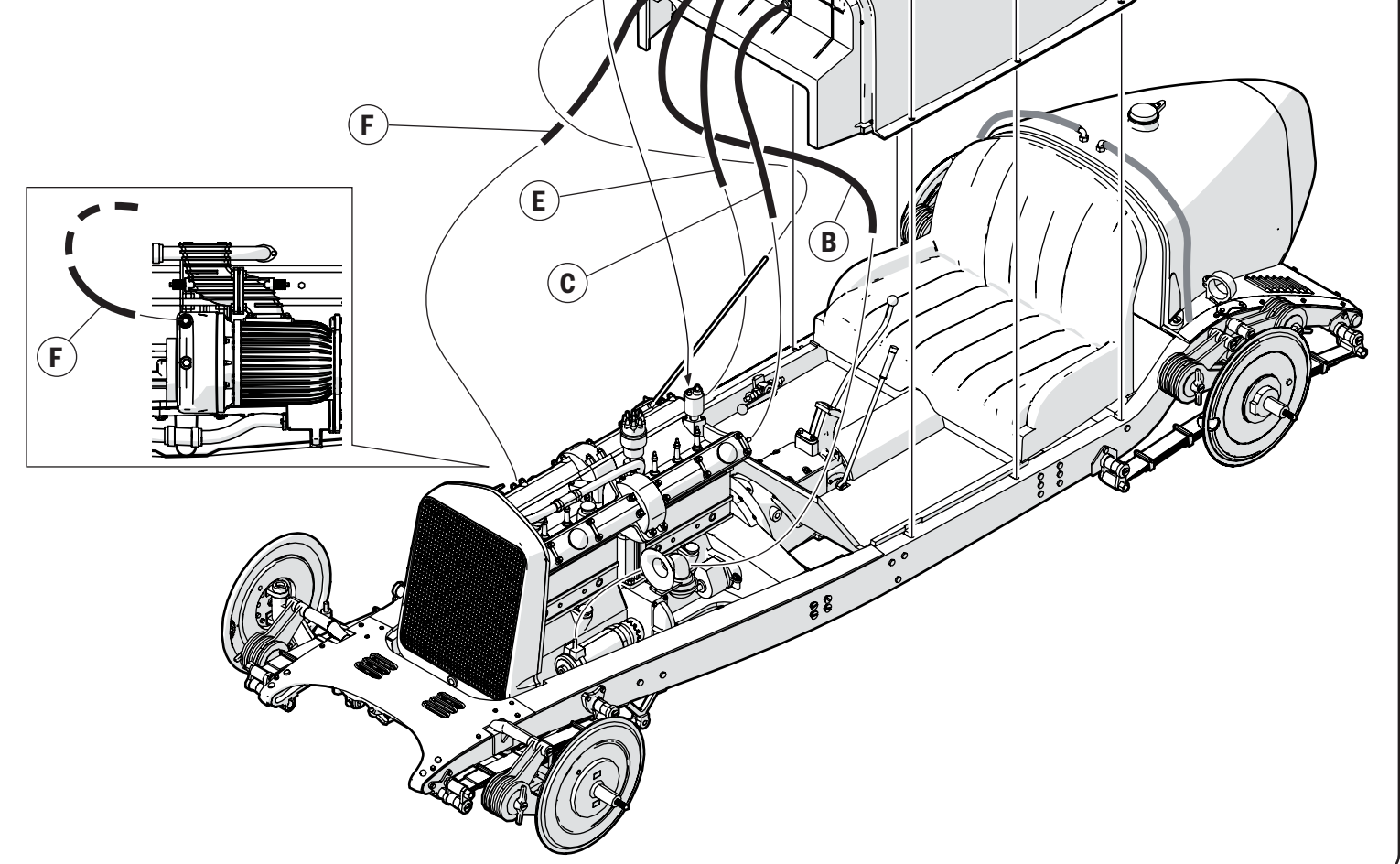
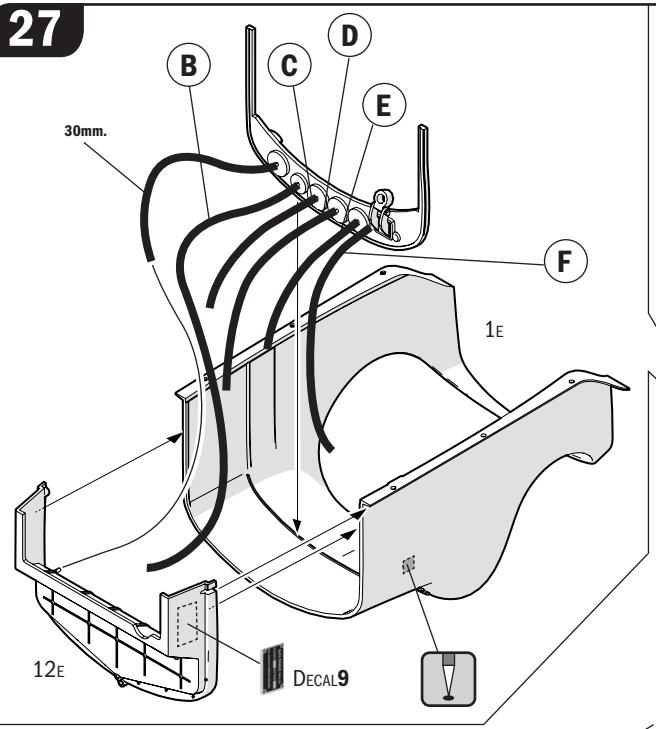
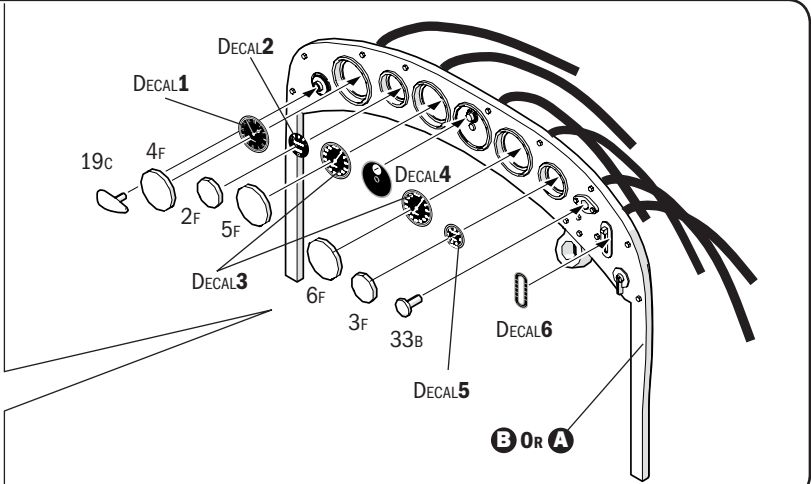
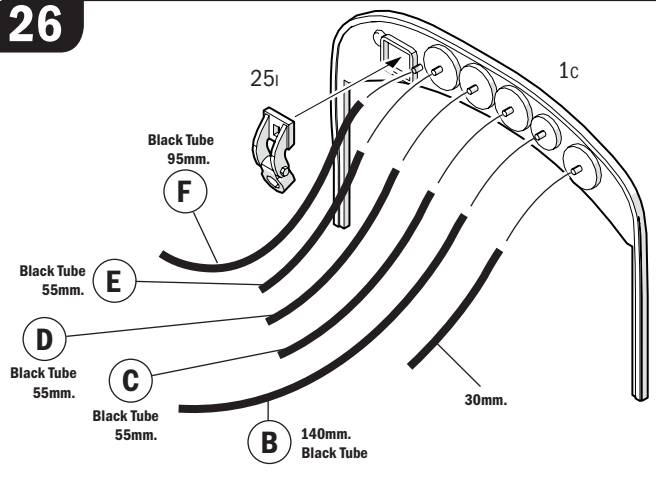

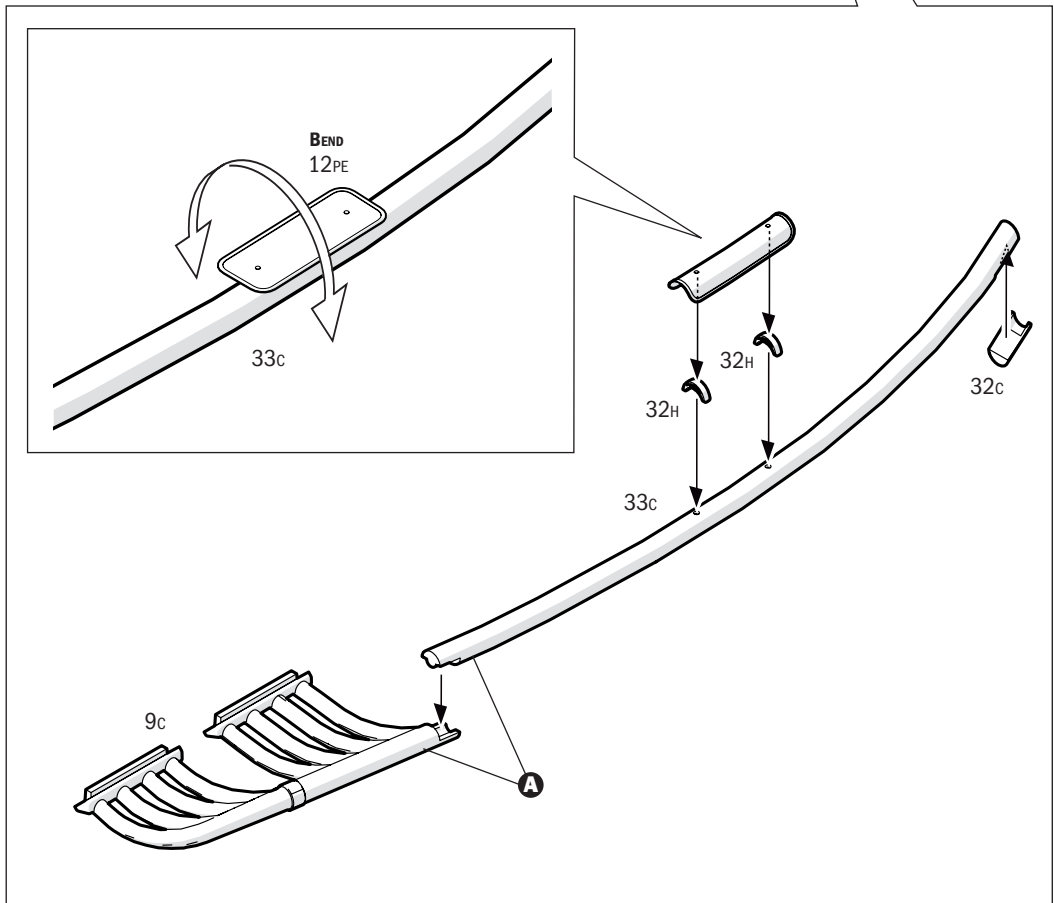
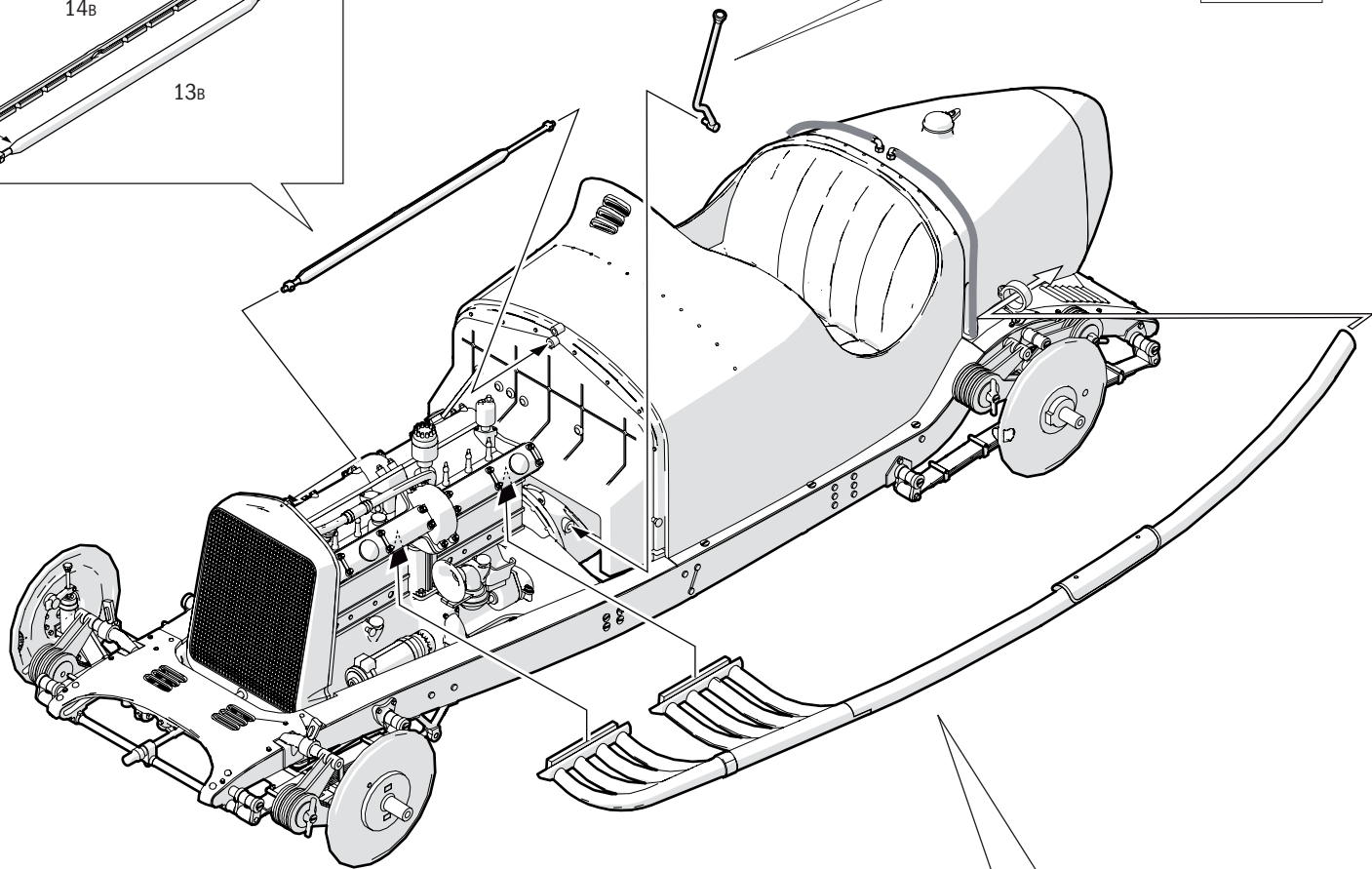
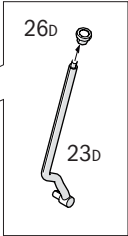
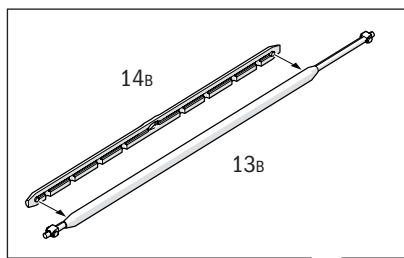

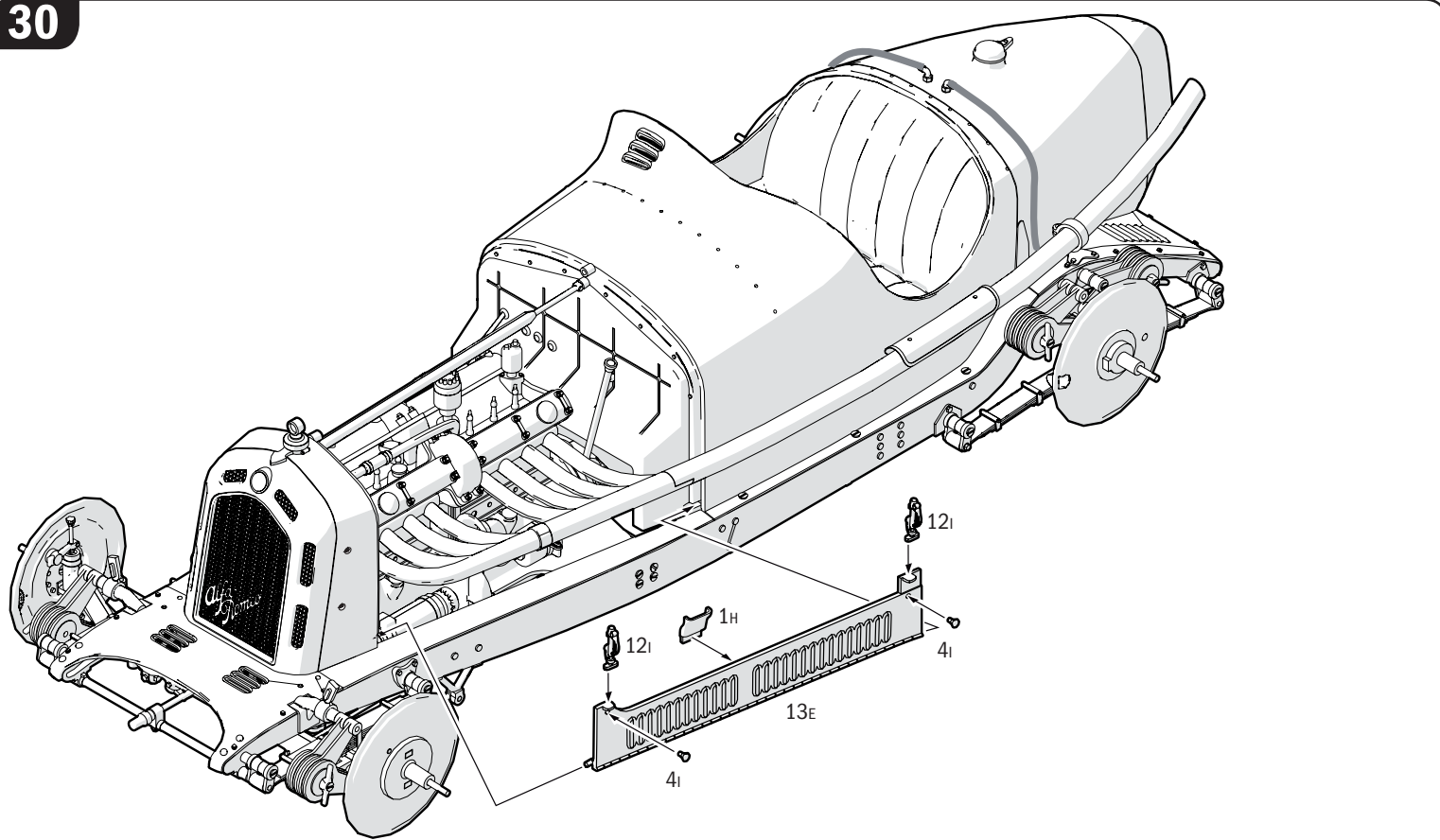
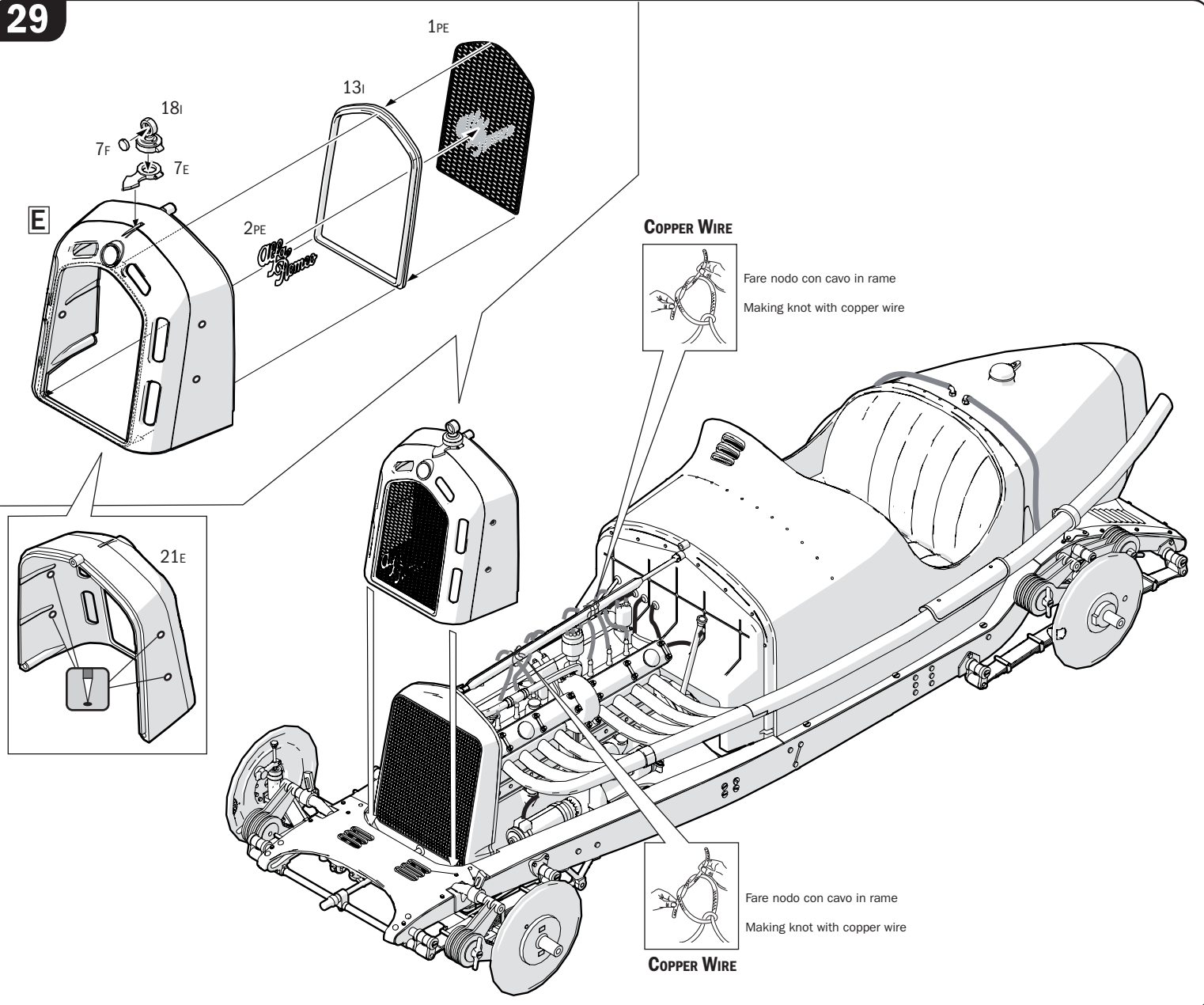

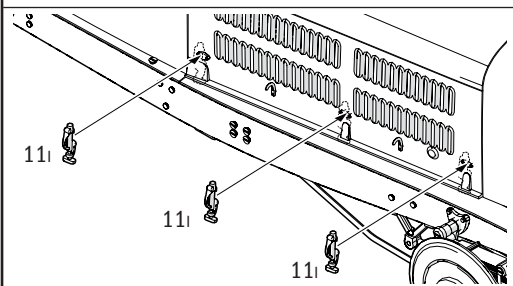
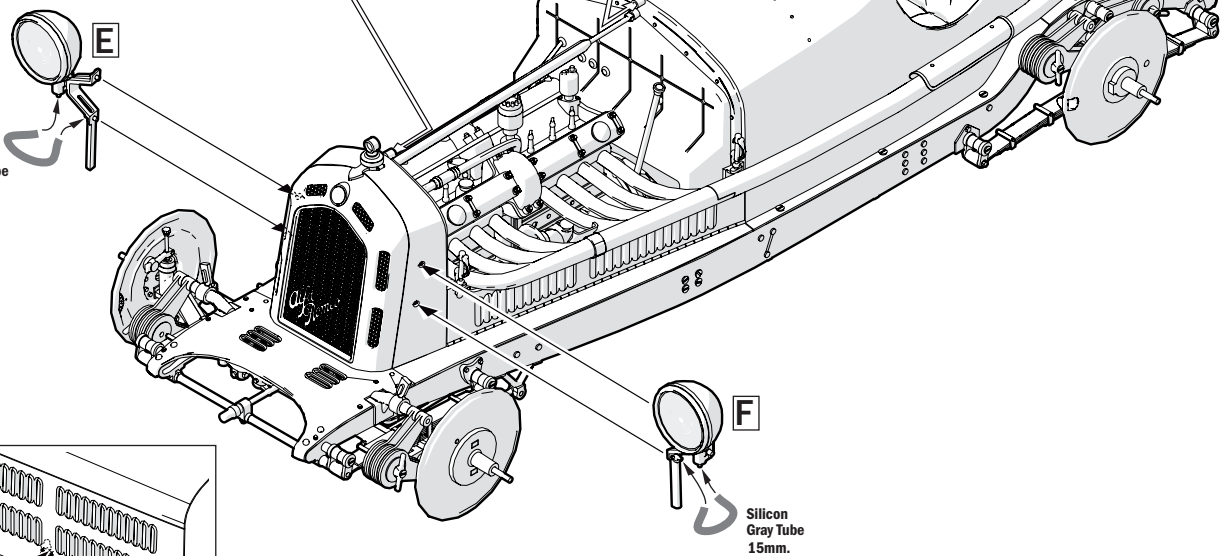
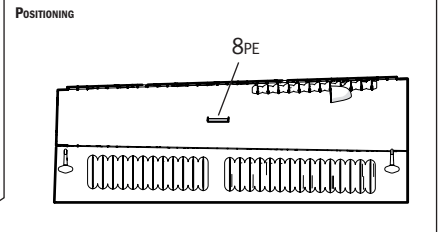
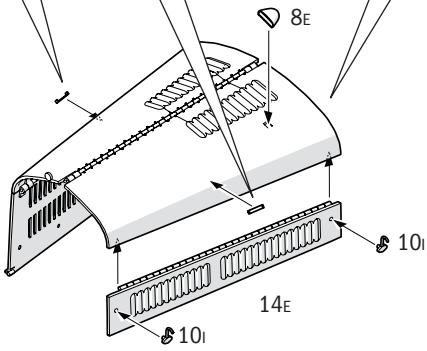
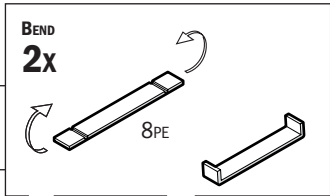
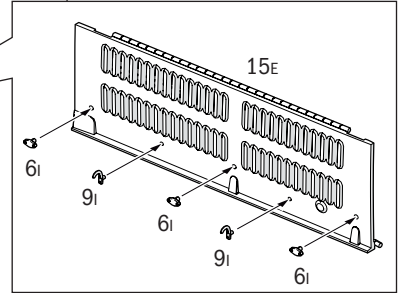
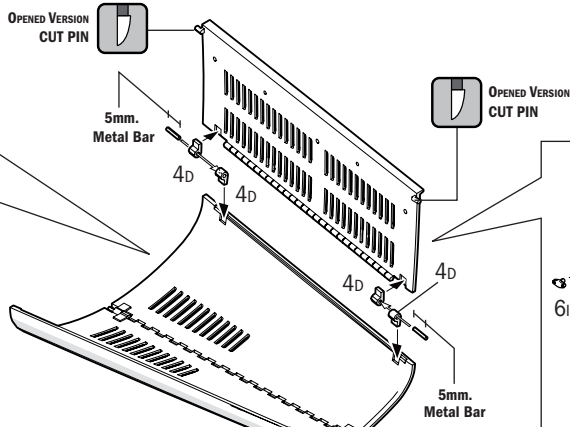
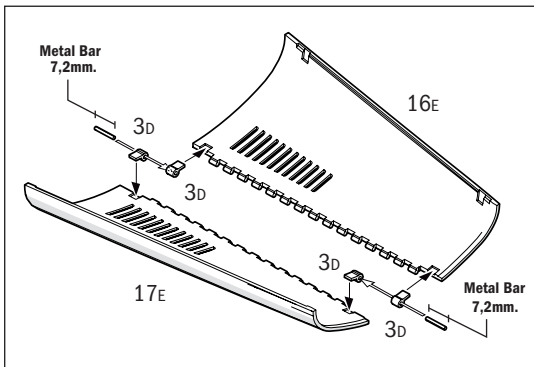
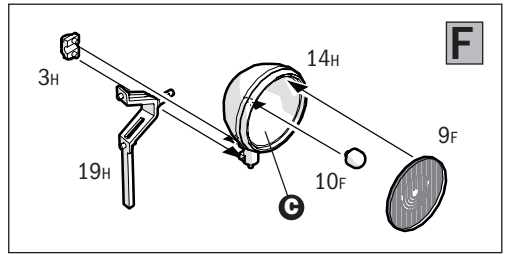
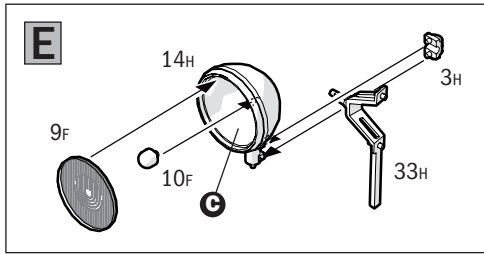

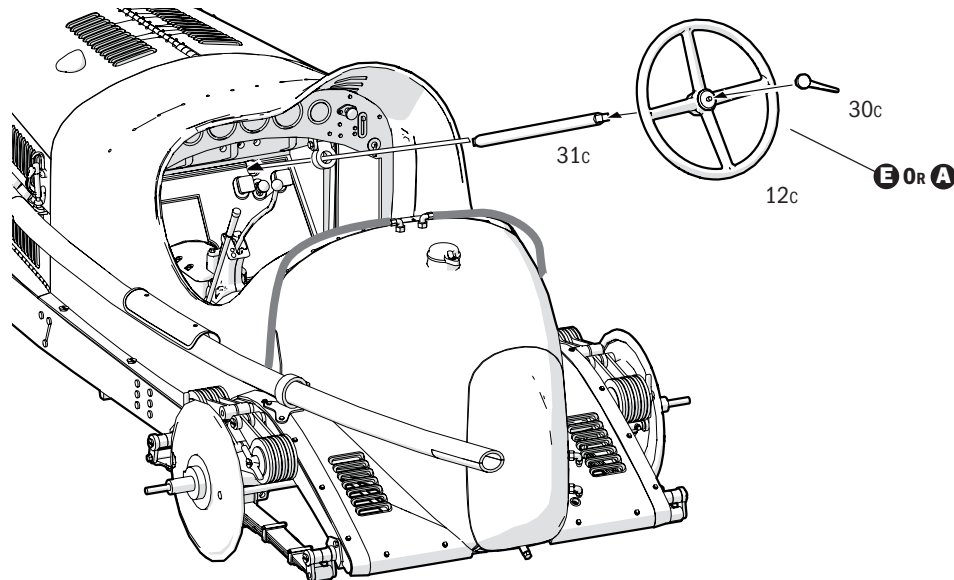
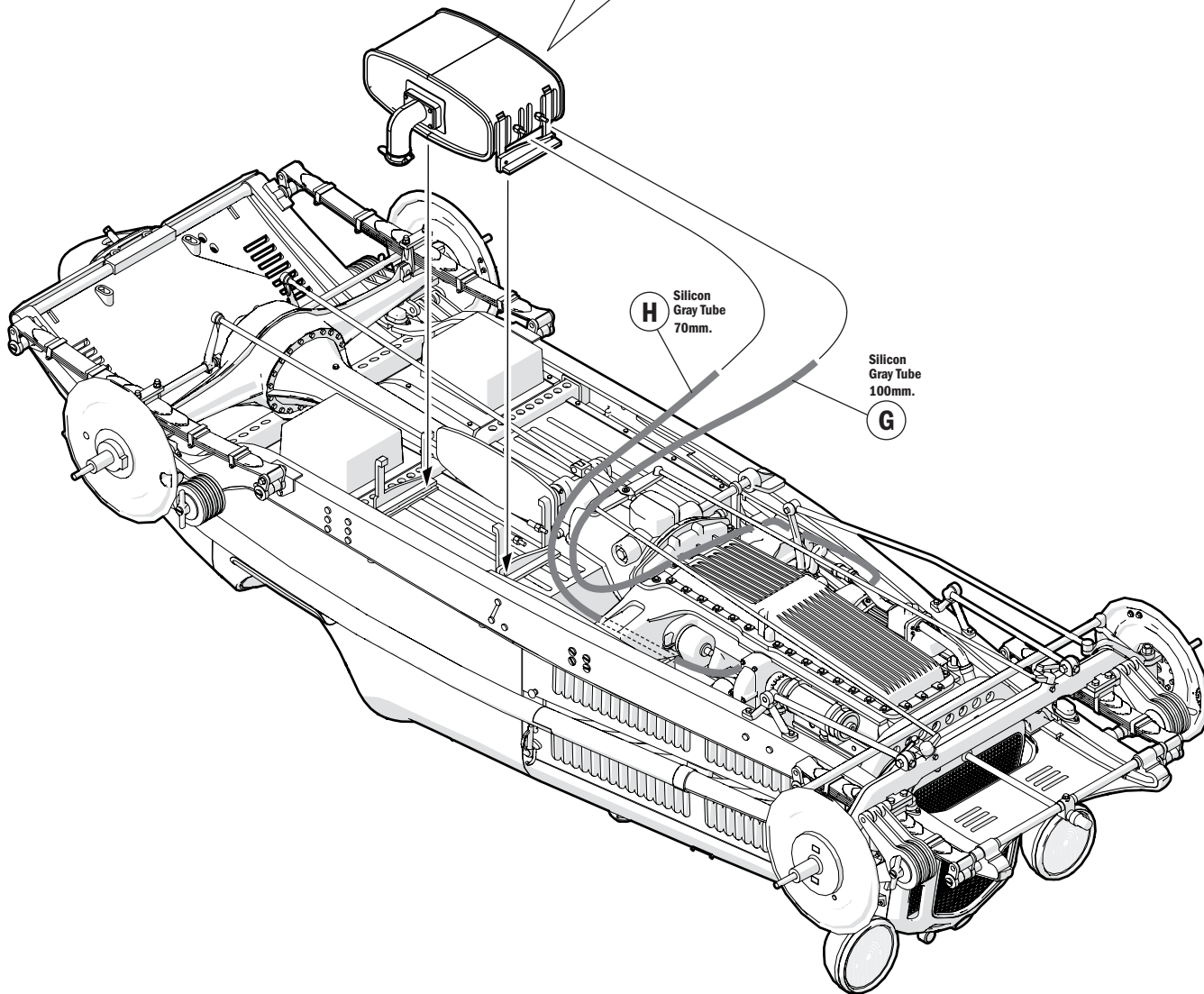
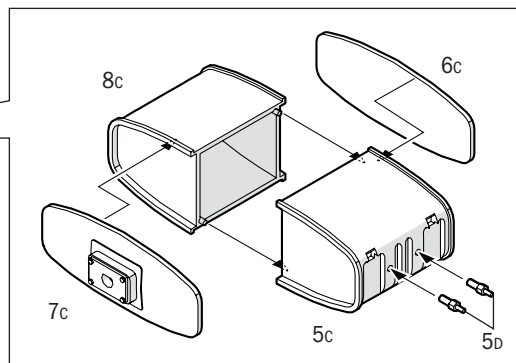
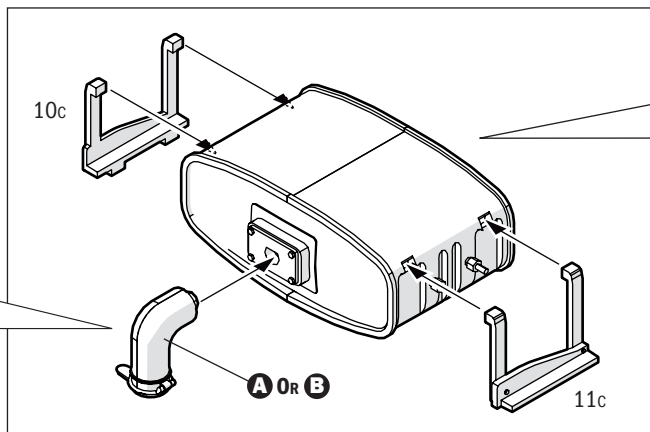
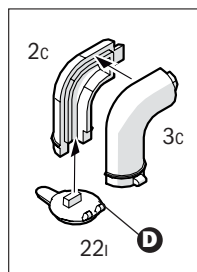

34

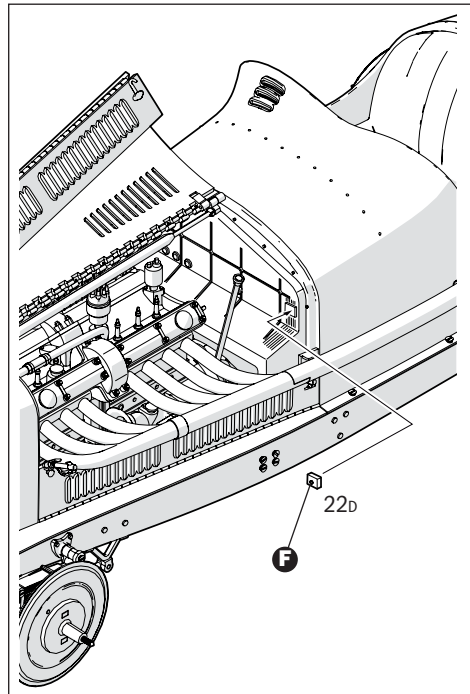
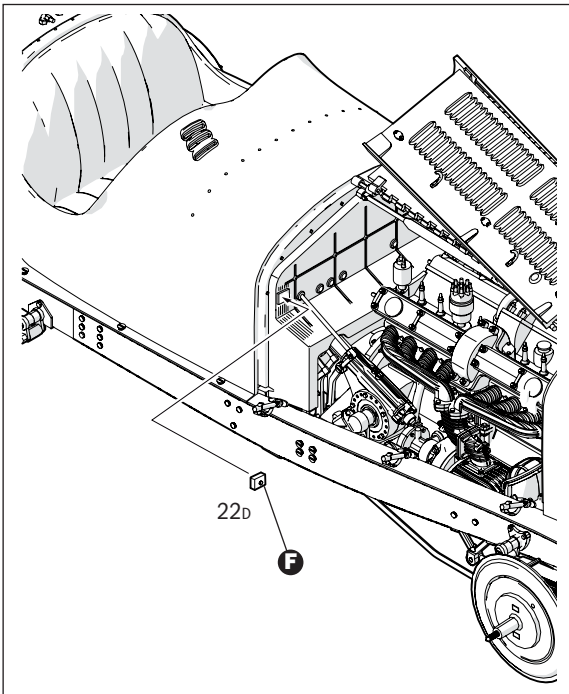

35

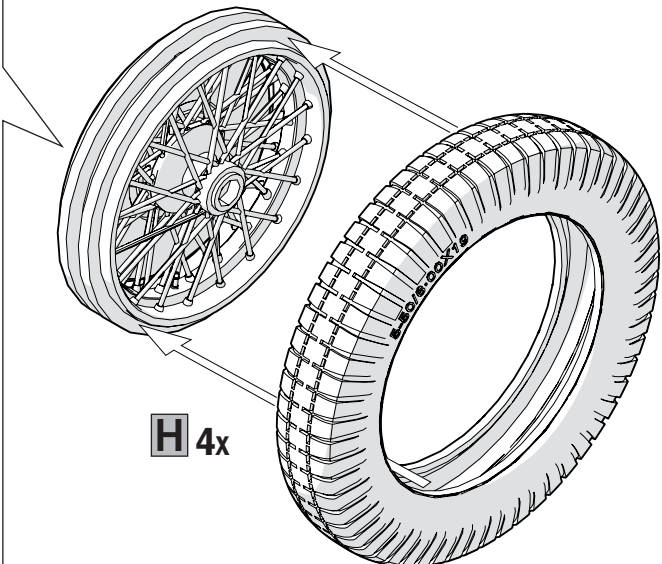
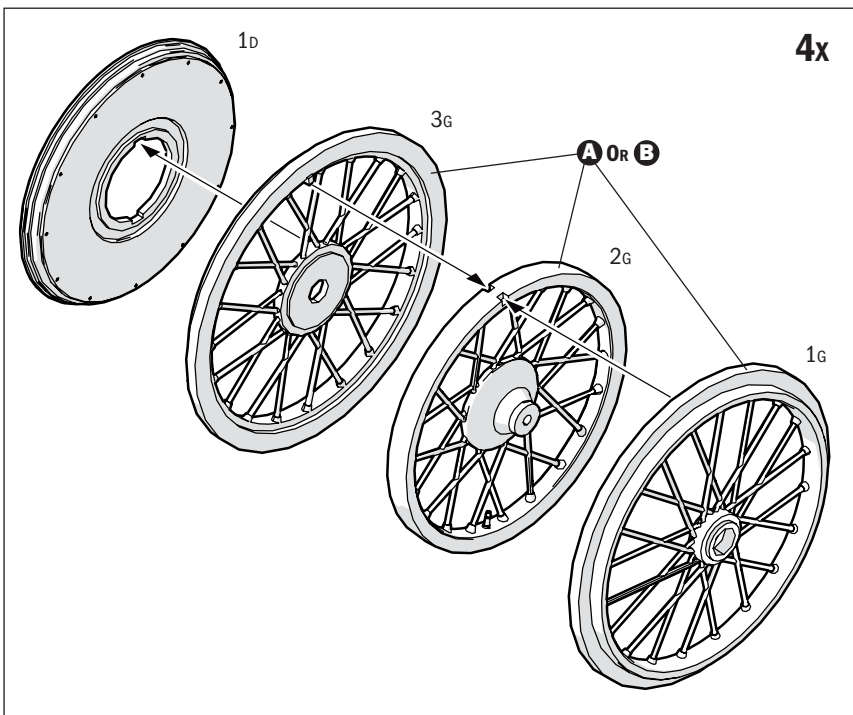
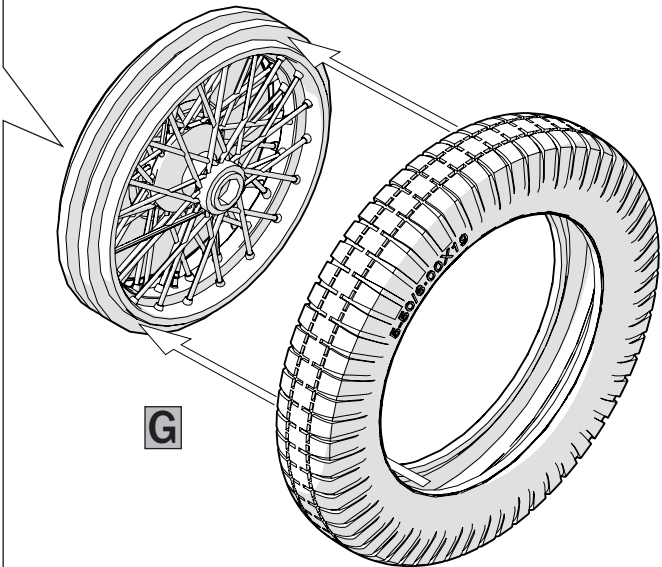
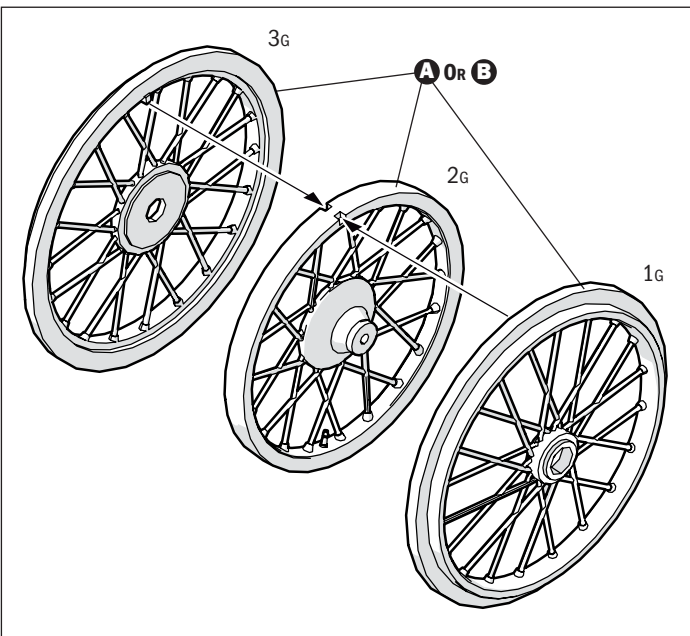



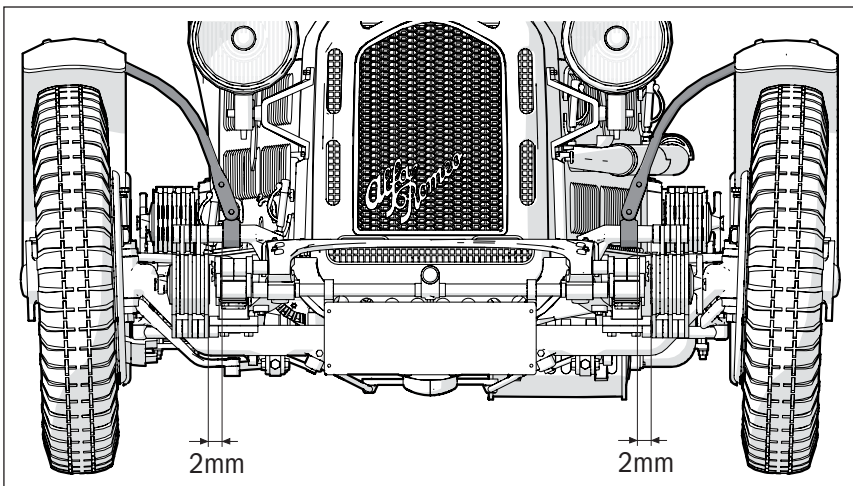
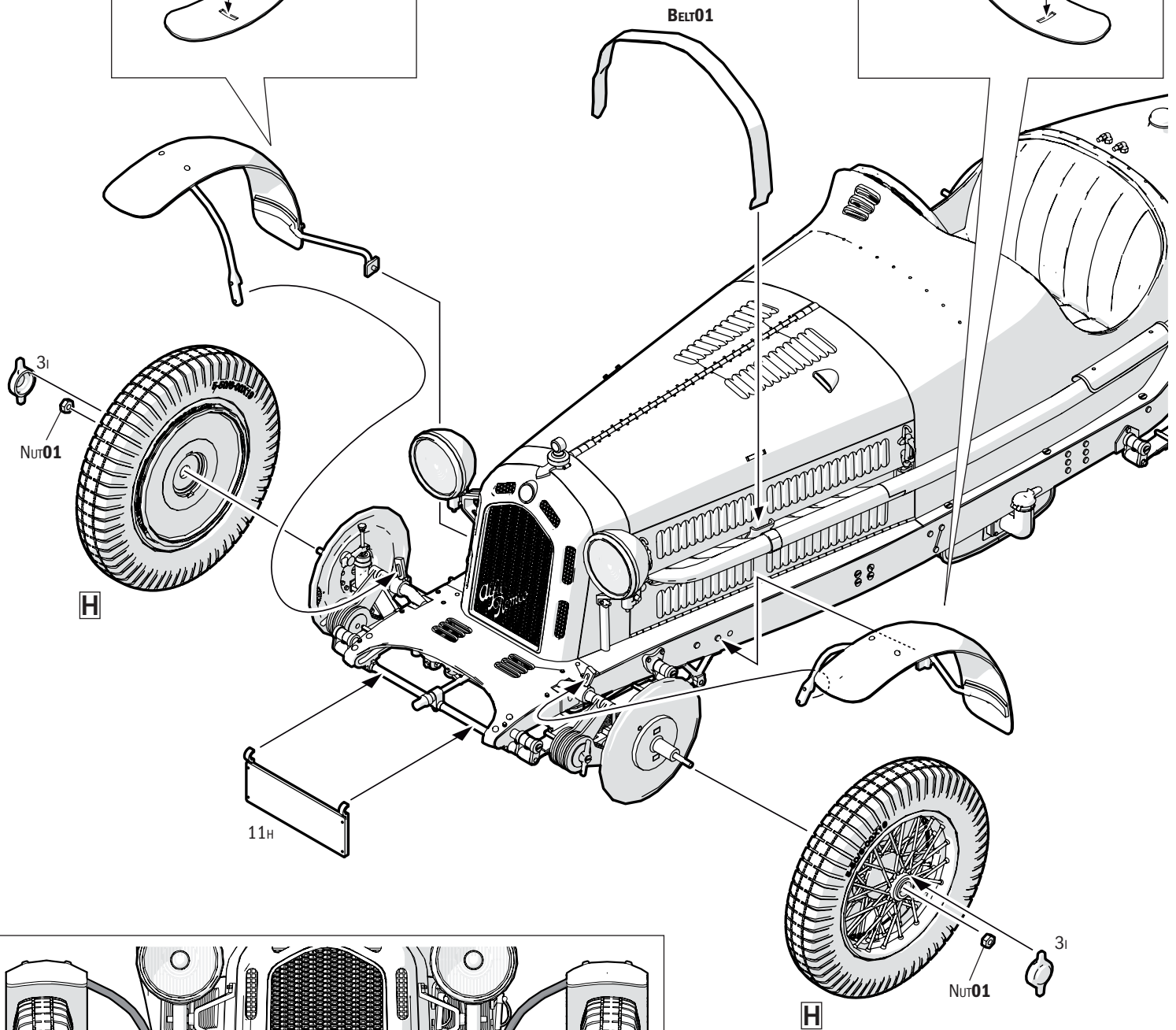
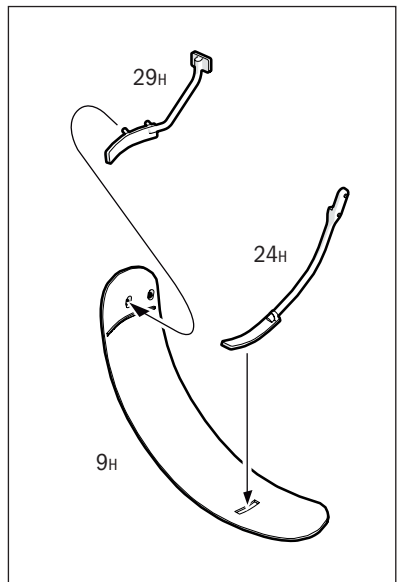
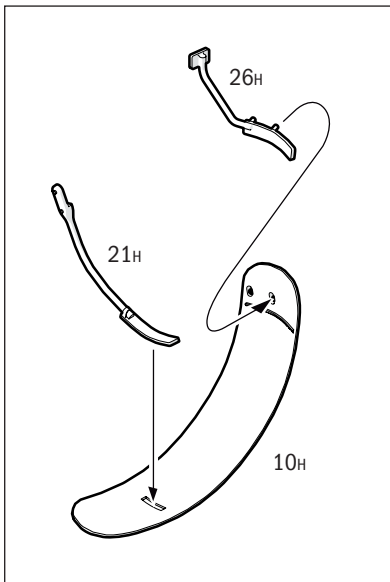

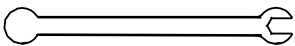
 Please use this wrench for NUT 01

Usare come chiave inglese per il DADO 01

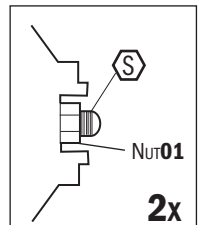

**NUT LOCKING**

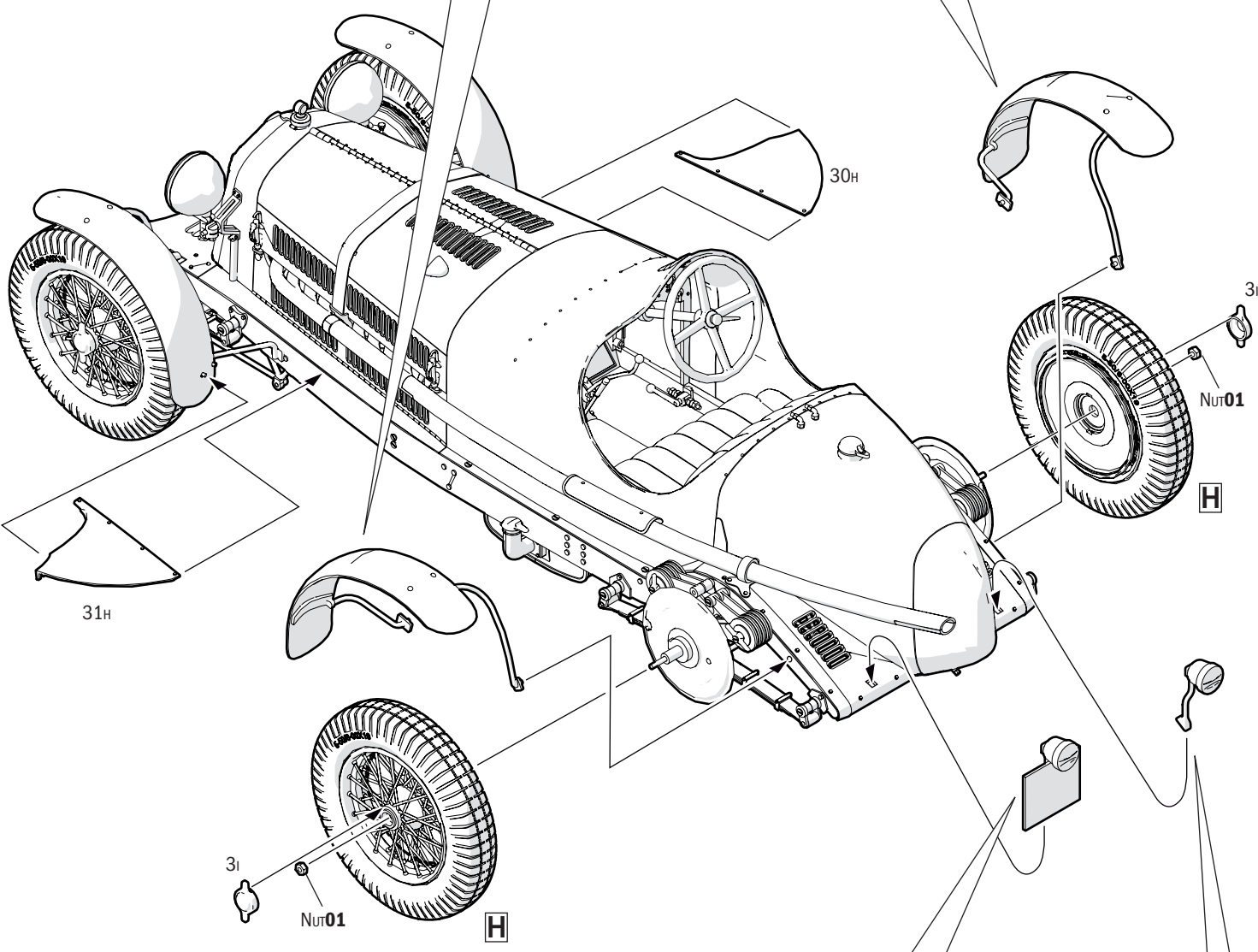
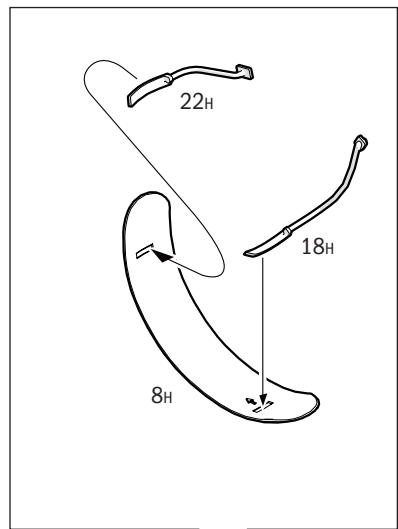
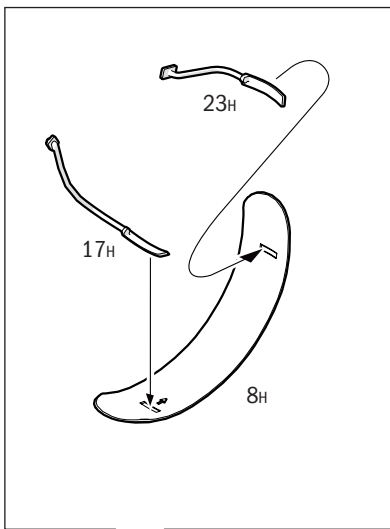

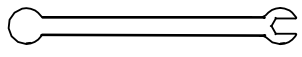
  
 Please use this wrench for **NUT 01**  
 Usare come chiave inglese per il **DADO 01**

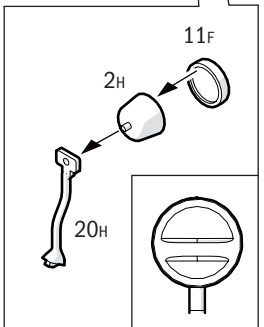
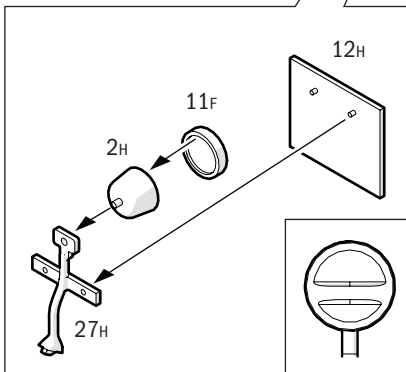
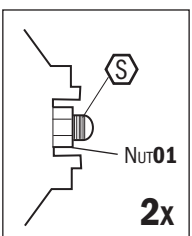

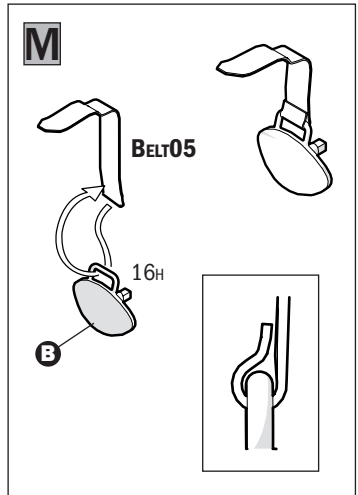
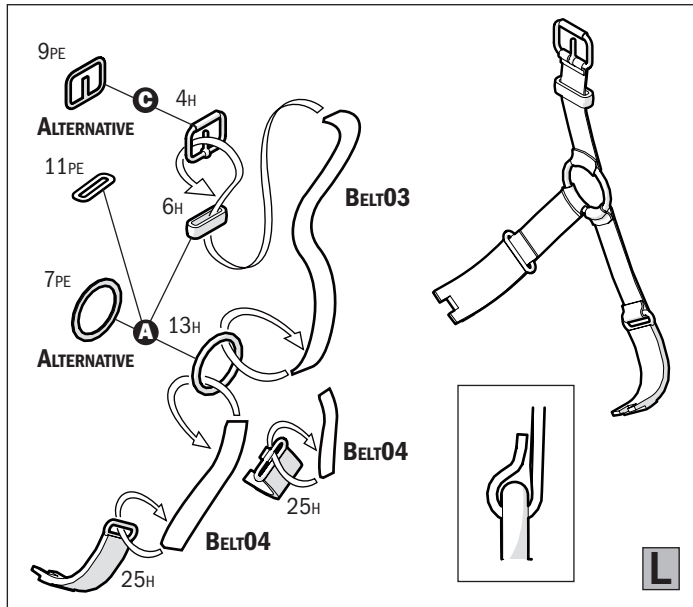
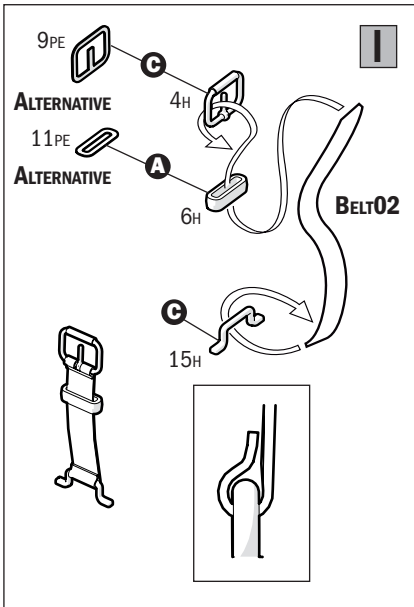
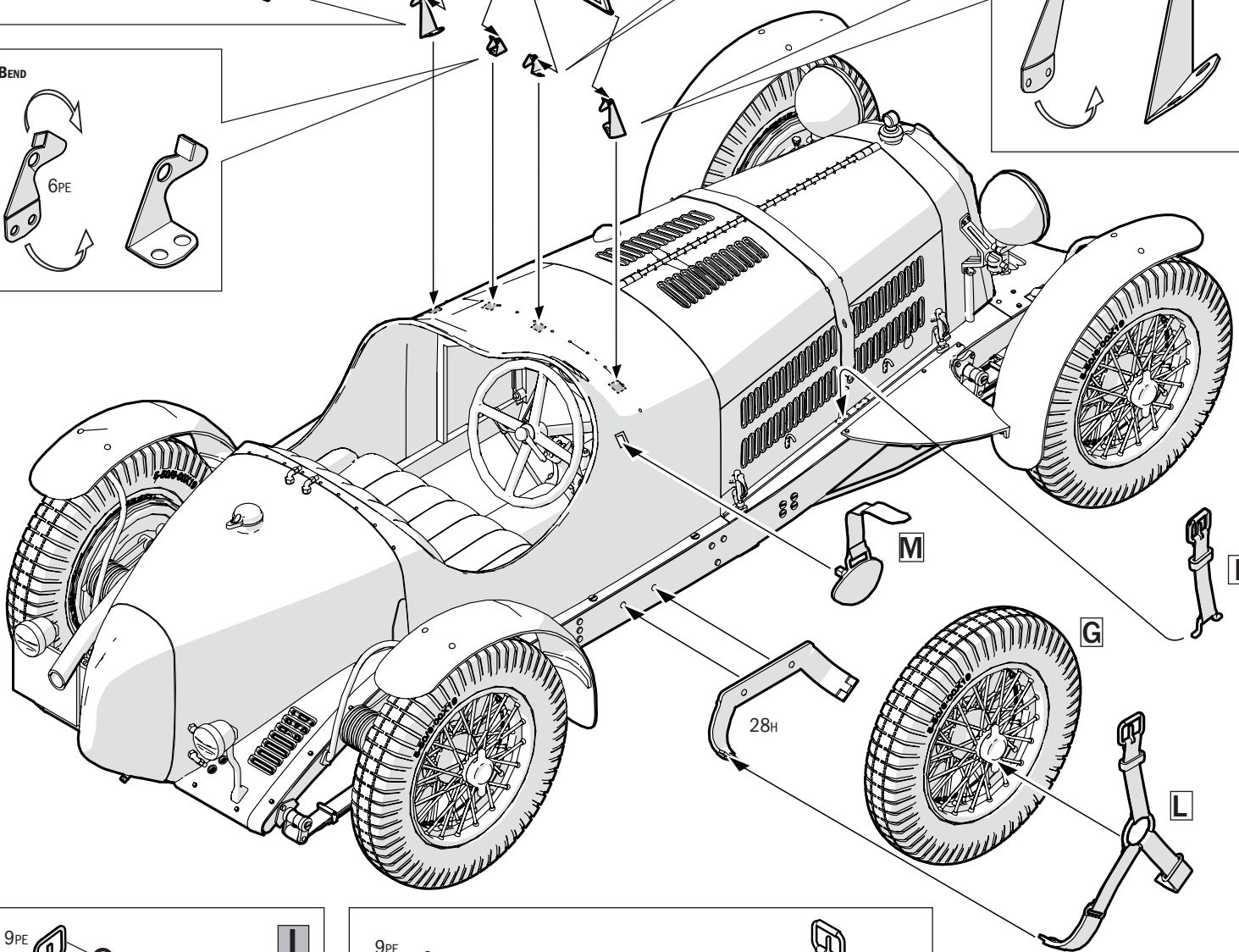
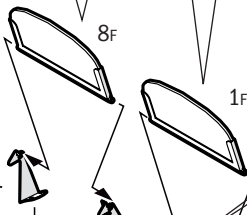
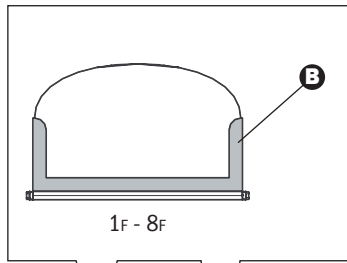
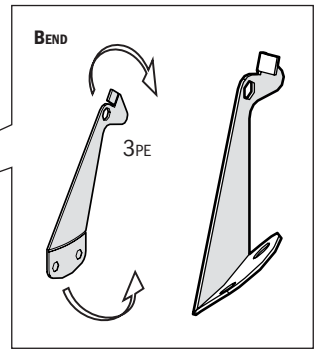
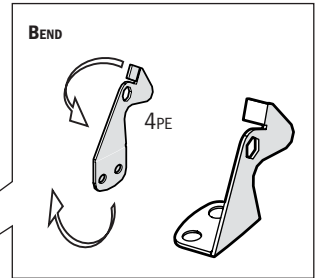
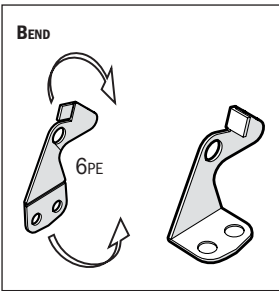
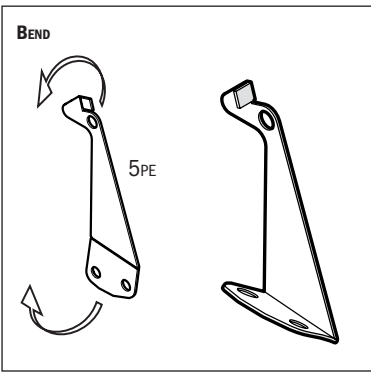

Istruzioni per l'applicazione delle decalcomanie. Ritagliare le decalcomanie occorrenti dal foglio, immergerle in un bicchiere di acqua pulita per circa 20", metterle in posizione sul modello e farle scivolare dalla carta: per una migliore aderenza comprimerle con una pezzuola pulita.

Direction for applying the decals: cut the required decals out of the sheet; dip the into a glass of clean water for about 20"; position the decals on the kit, letting them slide from the paper. For a better adhesion, press them by means of a clean rag.

Påläggning av decal: klipp ut den decal som skall användas och doppa den i ett glas vatten under en 20". Sätt decalen på plats på modellen och låt den sakta glida av pappret. För att den skall sitta ordentligt, tryck till med en torr duk.

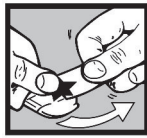

Anweisungen für Abziehbilder-Anbringung: Die benötigten Abziehbilder vom Blatt abschneiden, in ein Glas reines Wasser für etwa 20" eintauchen, auf das Modell legen und dann vom Papierbogen abnehmen. Um eine bessere Haftung zu erzielen, die Abziehbilder mit einem reinen Tuch andrücken.

Instruction pour l'application des décalcomanies. Couper les décalcomanies choisies et les plonger environ 20" dans un peu d'eau propre. Les placer sur le modèle en les faisant glisser de leur feuille et presser avec un morceau de chiffon pour éliminer les bulles d'air.

Istrucciones Para la aplicación de las calcomanías: cortar las requeridas, sumergirlas en un recipiente de agua limpia durante 20", colocar las calcomanías sobre el modelo, haciéndolas deslizar sobre el papel. Para una mejor adherencia, presionarlas con un trapico limpio.

Transfers: knip het benodigde deel uit, dempel et ca. 20" onder water, oudt het transfer tegen het model en schuif het vanaf het papier op zijn plaats. Met een schoon doekje aandrukken.

デカール使用法 台紙から、それぞれのマークを切り取ります。ぬるま湯に20秒くらいつけて、引き上げます。マークをすべらすようにして台紙からとり、指定の位置にはってください。やわらかな布でマーク上を押して気泡を取ってください。マーク面には、かわくまで水をふれないでください。

Указания по применению декалей: Отрежьте нужную вам часть декали от общего листа, поместите ее на 20" минуты в чистую воду, затем, выбрав необходимое место на модели, переведите туда изображение, сдвинув его с бумажной основы. Для лучшего прилипания промакните декаль чистой тряпочкой.

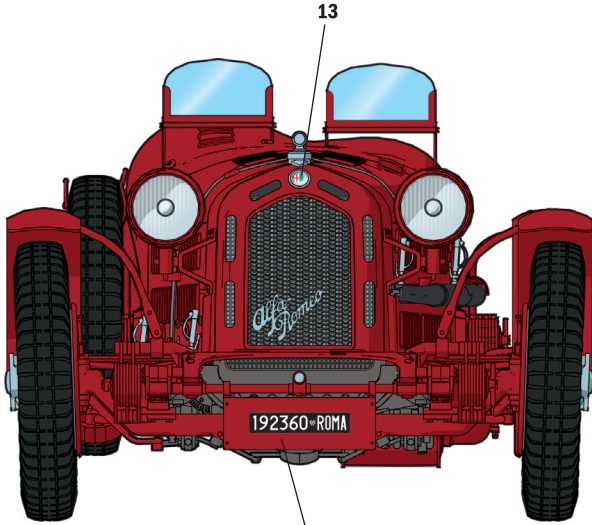

14 (Optional)

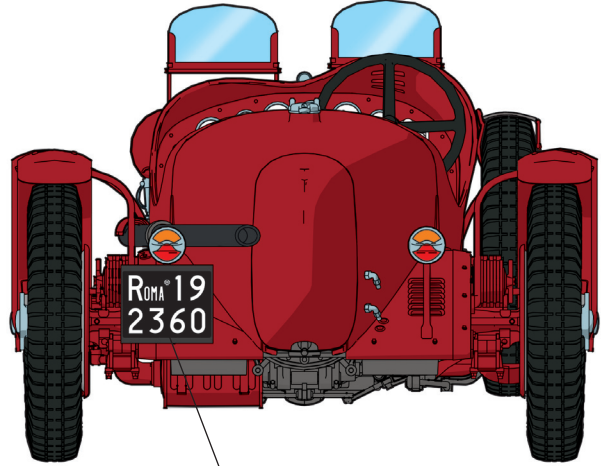

15 (Optional)

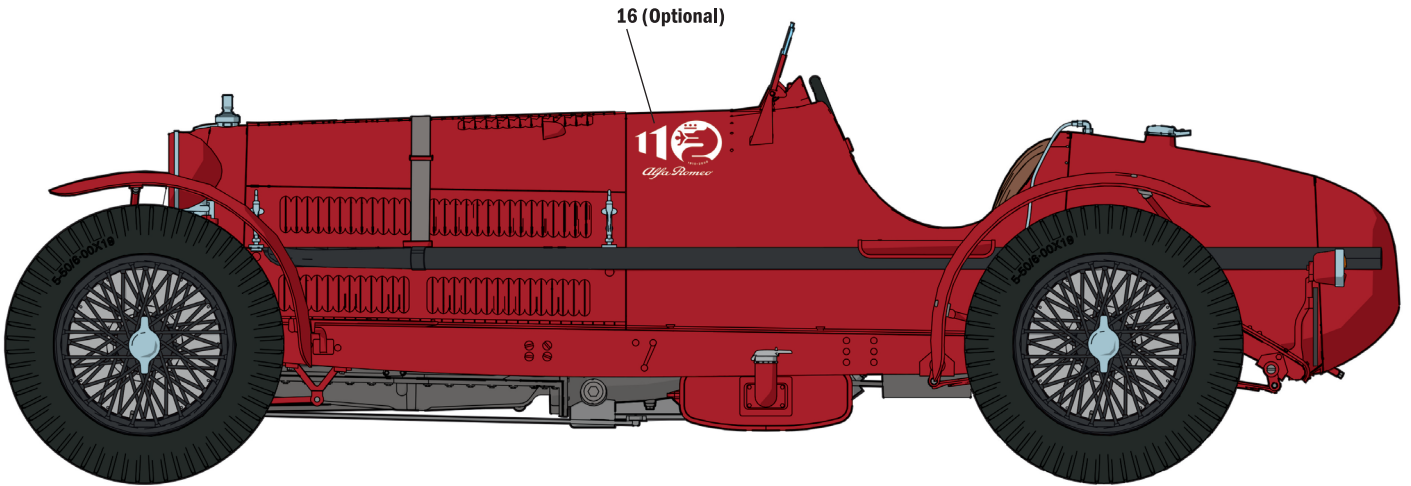

16 (Optional)

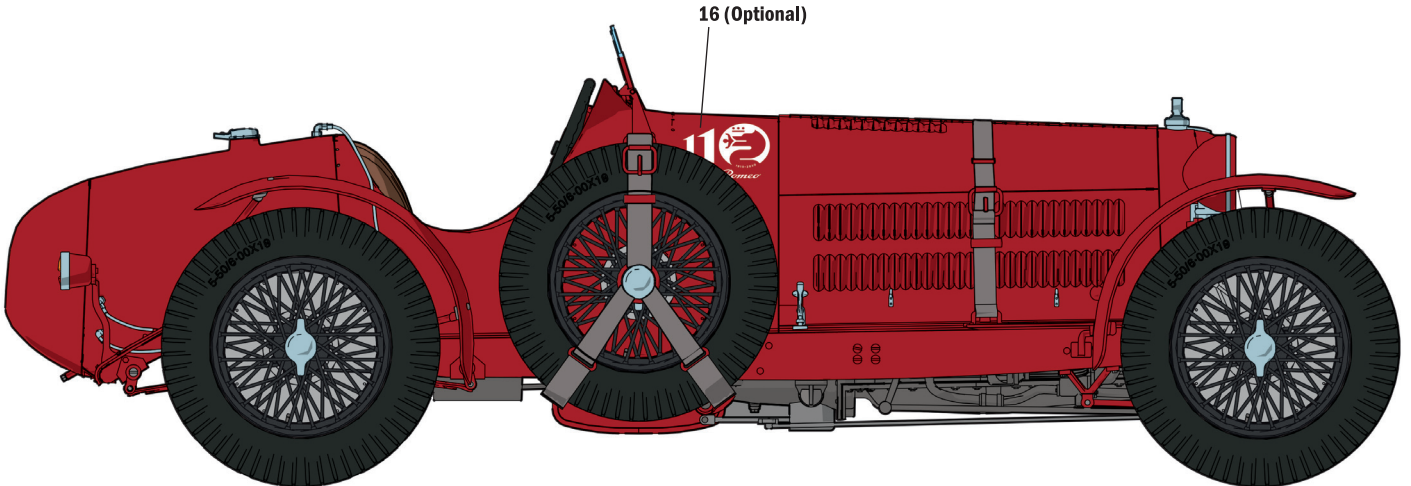

16 (Optional)

	<b>TAMIYA TS 39</b> MICA RED		<b>METAL GLOSS SILVER</b> ITALERI 4678AP		<b>FLAT LEATHER</b> ITALERI 4674AP		<b>METAL GLOSS BRASS</b> ITALERI 4672AP		<b>FLAT BLACK</b> ITALERI 4768AP		<b>FLAT WHITE</b> ITALERI 4769AP
--	---------------------------------	--	---	--	---------------------------------------	--	--	--	-------------------------------------	--	-------------------------------------