

Getting started with the X-NUCLEO-IKS01A3 motion MEMS and environmental sensor expansion board for STM32 Nucleo

Introduction

The X-NUCLEO-IKS01A3 is a motion MEMS and environmental sensor evaluation board system.

It is compatible with the Arduino UNO R3 connector layout and features the [LSM6DSO](#) 3-axis accelerometer + 3-axis gyroscope, the [LIS2MDL](#) 3-axis magnetometer, the [LIS2DW12](#) 3-axis accelerometer, the [HTS221](#) humidity and temperature sensor, the [LPS22HH](#) pressure sensor, and the [STTS751](#) temperature sensor.

The X-NUCLEO-IKS01A3 interfaces with the STM32 microcontroller via the I²C pin, and it is possible to change the default I²C port.

Figure 1. X-NUCLEO-IKS01A3 expansion board

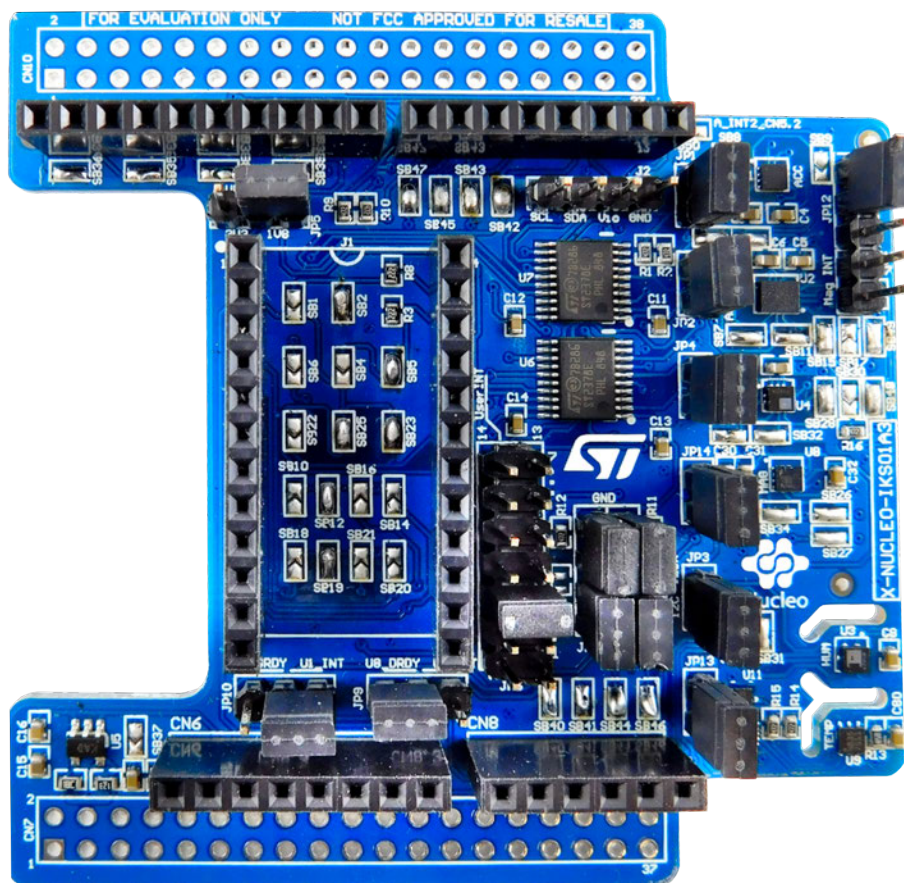

1 Getting started

1.1 Hardware requirements

The X-NUCLEO-IKS01A3 is designed to be used with STM32 Nucleo boards (visit www.st.com for further information).

Figure 2. X-NUCLEO-IKS01A3 plugged on an STM32 Nucleo board

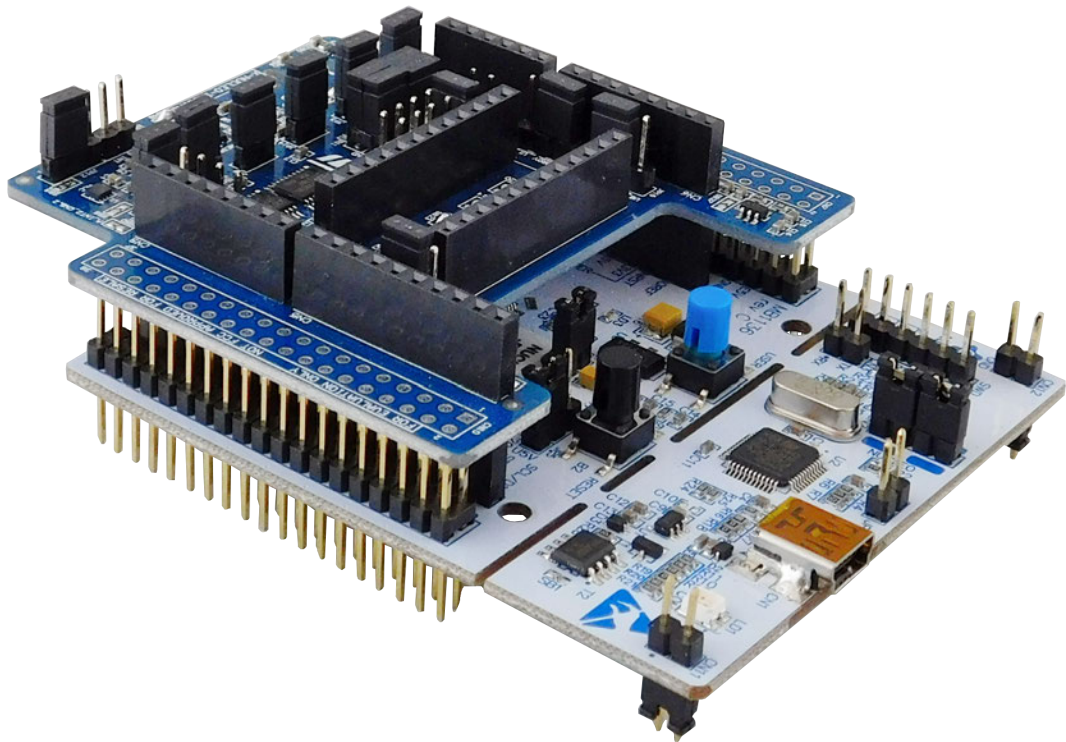

The X-NUCLEO-IKS01A3 must be connected on the matching pins of any STM32 Nucleo board with the Arduino UNO R3 connector.

Note: X-NUCLEO-IKS01A3 components are ESD sensitive and, as the board has male/female pass-through connectors, it is important to handle it with care to avoid bending or damaging the pins.

RELATED LINKS

See the X-CUBE-MEMS1 product page for firmware and related documentation

2 System requirements

To complete the system setup, you need:

- a Windows® (7, 8, 10) PC
- a USB type A to mini-B USB cable to connect the STM32 Nucleo to the PC
- board firmware and software package (X-CUBE-MEMS1) installed on the user PC

3 Hardware description

The board lets you test the functionality of the motion MEMS accelerometer, gyroscope and magnetometer, and environmental humidity, temperature and pressure sensors, via the I²C communication bus.

It also allows all [LSM6DSO](#) sensor hub function testing.

The board features:

- LSM6DO: MEMS 3D accelerometer ($\pm 2/\pm 4/\pm 8/\pm 16$ g) + 3D gyroscope ($\pm 125/\pm 250/\pm 500/\pm 1000/\pm 2000$ dps)
- LIS2MDL: MEMS 3D magnetometer (± 50 gauss)
- LIS2DW12: MEMS 3D accelerometer ($\pm 2/\pm 4/\pm 8/\pm 16$ g)
- LPS22HH: MEMS pressure sensor, 260-1260 hPa absolute digital output barometer
- HTS221: capacitive digital relative humidity and temperature
- STTS751: Temperature sensor (-40 °C to $+125$ °C)
- DIL 24-pin socket available for additional MEMS adapters and other sensors
- Free comprehensive development firmware library and example for all sensors compatible with STM32Cube firmware
- I²C sensor hub features on LSM6DSO available
- Compatible with STM32 Nucleo boards
- Equipped with Arduino UNO R3 connector
- RoHS compliant
- WEEE compliant

Each device has a separate power supply to allow power consumption measurement of every sensor.

The expansion board is power supply compatible with STM32 Nucleo boards: it mounts an LDO to generate 1.8 V for all the MEMS sensors except for the [STTS751](#), which is supplied by a separate LDO generating 2.5 V.

All signals between the sensors and the main board are translated by a level shifter.

3.1 Default solder bridge configuration

The user can configure several aspects of the X-NUCLEO-IKS01A3 through several solder bridges which can be left open (not mounted) or closed (mounted) to configure different hardware settings.

Table 1. Default solder bridge default configuration (device to I²C bus connection)

Device	BUS	Solder bridge (default)	Solder bridge (not mounted)
LIS2DW12	I ² C2	SB3, SB13	-
LSM6DSO	I ² C2	SB7, SB11	-
HTS221	I ² C1	SB24, SB31	-
LPS22HH	I ² C1	SB29, SB32	-
STTS751	I ² C1	SB26, SB27	-
LIS2MDL	I ² C1	SB33, SB34	-
STM32 Nucleo	I ² C2	SB35, SB36	-
DIL24 Adapter	I ² C1	SB12, SB19	SB1, SB4, SB6, SB10, SB14, SB16, SB18, SB20, SB21, SB22
*DIL24 Adapter	I ² C2	SB16, SB21	SB1, SB4, SB6, SB10, SB14, SB12, SB18, SB20, SB19, SB22
*DIL24 Adapter	I ² Cx	SB14, SB20	SB1, SB4, SB6, SB10, SB12, SB16, SB18, SB19, SB21, SB22

Table 2. Device I²C address

Device	Solder bridge (non default)	I ² C address default
LIS2DW12	SB8	32h
LIS2DW12	SB9 ⁽¹⁾	30h
LSM6DSO	SB15	D6h
LSM6DSO	SB17 ⁽¹⁾	D4h
LIS2MDL	-	3C
STTS751	-	94h
LPS22HB	SB13	BAh
LPS22HB	SB14	B8h
HTS221	-	BEh

1. not mounted by default

Note: Other SBs mounted by default are SB40 to SB49 (STM32 Nucleo GPIO INT), SB23, SB25, SB39
 Other SBs not mounted by default are SB38, SB37, SB50

3.2 Block diagram

The LSM6DSO has an I²C sensor hub which allows it to behave as the I²C master for other slave devices connected via an I²C_{aux} bus. Various configurations are possible for different I²C bus connections with or without the LSM6DSO sensor hub.

Mode 1: standard I²C bus connection (all sensors)

In standard I²C mode, all devices are connected to an external main board via the same I²C bus.

The board configuration is:

- JP7: 1-2, 3-4 (I²C1 = I²C2, I²Cx=GND)
- JP8: 1-2, 3-4 (I²C1 = I²C2, I²Cx=GND)

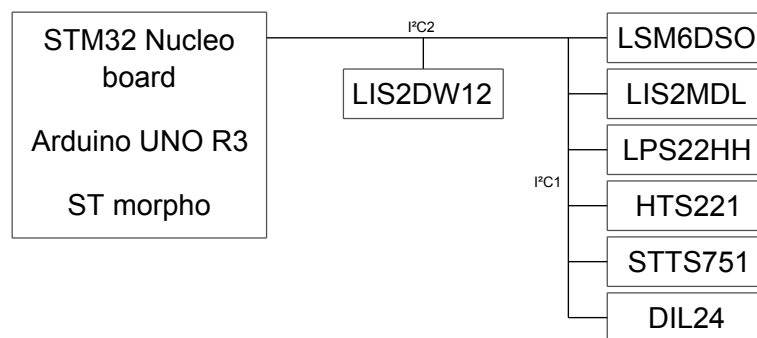
Figure 3. X-NUCLEO-IKS01A3 standard I²C

Mode 2: LSM6DSO I²C sensor hub (all sensors)

In this sensor hub I²C mode, the LSM6DSO is connected to an external main board by an I²C bus; all other devices except LIS2DW12 are slaves connected to LSM6DSO via I²C_{aux}.

The board configuration is:

- JP7: 2-3 (I²C1 = I²Cx)
- JP8: 2-3 (I²C1 = I²Cx)

Figure 4. X-NUCLEO-IKS01A3 LSM6DSO I²C sensor hub

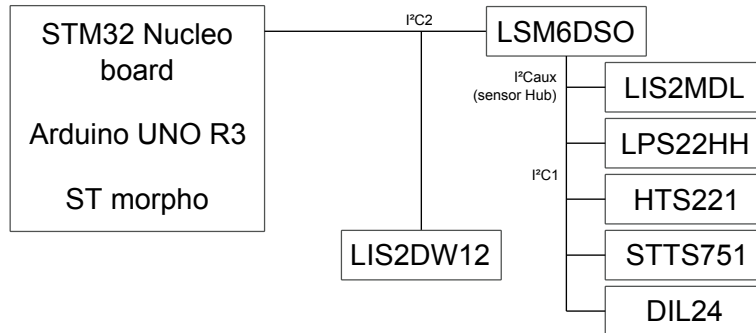

Mode 3: DIL24 plus LSM6DSO I²C sensor hub (all sensors, not DIL24)

In this sensor hub I²C mode, the LSM6DSO and the DIL24 adapter are connected to an external main board by an I²C bus; all other devices except LIS2DW12 are slaves of the LSM6DSO via I²C_{aux}.

The board configuration is:

- JP7: 2-3 (I²C1 = I²Cx)
- JP8: 2-3 (I²C1 = I²Cx)

DIL24 adapter (to I²C2): SB16, SB21

Not mounted: SB6, SB10, SB12, SB14, SB18, SB19, SB20, SB22

Figure 5. X-NUCLEO-IKS01A3 DIL24, LSM6DSO I²C sensor hub (all sensors)

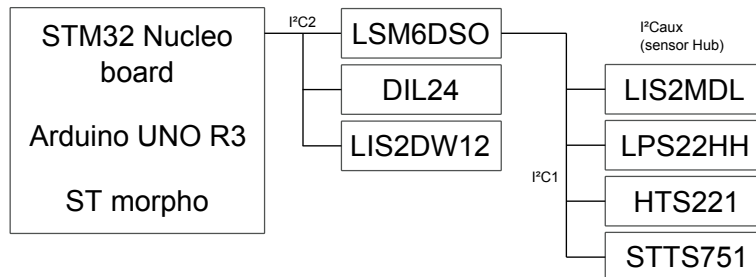

Mode 4: LSM6DSO plus DIL24 I²C sensor hub (all sensors)

In this sensor hub I²C mode, the LSM6DSO and the DIL24 adapter are connected to an external main board by an I²C bus; all other devices except LIS2DW12 are slaves of the DIL24 adapter via I²C_{aux}.

The board configuration is:

- JP7: 2-3 (I²C1 = I²Cx)
- JP8: 2-3 (I²C1 = I²Cx)

DIL24 adapter (to I²C2): SB12, SB19

Not mounted: SB6, SB10, SB14, SB16, SB18, SB20, SB21, SB22

Figure 6. X-NUCLEO-IKS01A3 LSM6DSO, DIL24, I²C sensor hub (all sensors)

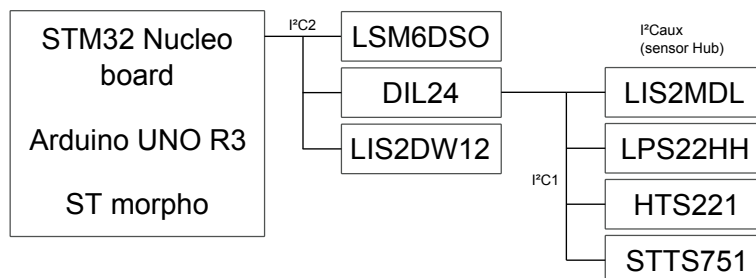

Mode 5: LSM6DSO plus I²C sensor hub DIL24

In this sensor hub I²C mode, the LSM6DSO and other sensors are connected to an external main board via an I²C bus; the DIL24 adapter is a slave of the LSM6DSO via I²C_{aux}.

The board configuration is:

- JP7: 1-2 (I²C1 = I²Cx)
- JP8: 1-2 (I²C1 = I²Cx)

DIL24 adapter (to I²Cx): SB14, SB20

Not mounted: SB6, SB10, SB12, SB16, SB18, SB19, SB21, SB22

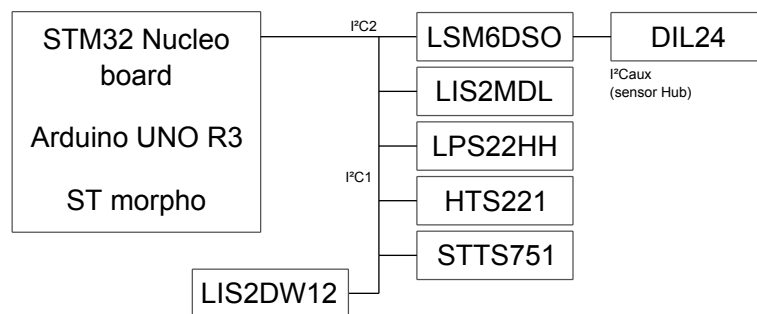
Figure 7. X-NUCLEO-IKS01A3 LSM6DSO plus sensor hub DIL24

3.3 Sensor I²C address selection

Most sensors allow I²C address LSB selection by pulling the SD0 pin low or high. The board has solder bridges to control SD0 level.

Table 3. Solder bridges for SD0 level control and I²C address

Sensor	SD0 high	SD0 low
STTS751 (U9)	ADD= 94h	
LIS2DW12(U1)	SB8 ADD=32h	SB9 ADD=30h
LSM6DSO (U2)	SB15 ADD=D6h	SB17 ADD=D4h
LPS22HH (U4)	SB28 ADD=BAh	SB30 ADD=B8h
LIS2MDL (U8)	ADD =3Ch	ADD =3Ch
HTS221 (U3)	ADD= BEh	ADD= BEh
DIL24 Adapter (J1)	SB1/SB2	SB4/SB5

3.4 Sensor current consumption measurement

The X-NUCLEO-IKS01A3 expansion board is equipped with jumpers which allow separate current consumption measurement for each sensor.

To measure current consumption, connect an ammeter to the appropriate jumper.

Note: As the sensors have very low current consumption, you should set a suitable range and use an ammeter with low burden voltage.

Table 4. Jumpers for current consumption measurement

Sensor	Jumper
LIS2MDL (U8)	JP14
LSM6DSO (U2)	JP11

Sensor	Jumper
HTS221 (U3)	JP3
LPS22HH (U4)	JP4
STTS751 (U9)	JP13
LIS2DW12 (U1)	JP1
DIL24 Adapter (J1)	JP5

3.5 Sensor disconnection

To disconnect a sensor, you should disconnect the I²C bus as well as the power supply. See the table below for the relevant jumpers and solder bridges.

Table 5. Link between sensors, jumpers and I²C solder bridges

Sensor	Power	SDA	SCL
LIS2MDL (U8)	JP14	SB34	SB33
LSM6DSO (U2)	JP11	SB11	SB7
HTS221 (U3)	JP3	SB24	SB31
LIS2DW12 (U1)	JP1	SB3	SB13
STTS751 (U9)	JP13	SB26	SB27
LPS22HH (U4)	JP4	SB32	SB29
DIL24 adapter	JP5	SB12,14,16	SB19,20,21

3.6 Adapter board for DIL24 socket

An additional sensor can be connected as an adapter board to J1 DIL24 socket.

As there are a few different interrupt signal assignments for DIL24 pins, the appropriate pin can be selected using the JP6 header.

RELATED LINKS

Please visit the [ST website](#) to find other available sensors

3.7 Connectors

Table 6. Arduino R3 UNO connectors

Connector	Pin ⁽¹⁾	Signal
CN5	7	GND
	9	I ² C SDA
	10	I ² C SCL
CN6	2	3.3 V
	4	3.3 V
	6	GND
	7	GND
	8	N.C.[FT1]

Connector	Pin ⁽¹⁾	Signal
CN8	3	LIS2MDL DRDY
	4	LIS2DW12 INT
	5	STTS751 INT
	6	INT1 (DIL24)
CN9	3	USER INT
	5	LSM6DSO INT1
	6	LSM6DSO INT2
	7	LPS22HH INT1

1. *unlisted pins are not connected.*

Table 7. ST morpho connectors

Connector	Pin ⁽¹⁾	Signal
CN7	12	3.3 V
	16	3.3 V
	20	GND
	22	GND
	32	LIS2MDL DRDY
	34	LIS2MDL DRDY
	36	STTS751 INT
	38	INT1 (DIL24)
CN10	3	I ² C SCL
	5	I ² C SDA
	25	LPS22HH INT1
	27	LSM6DSO INT2
	29	LSM6DSO INT1
	33	USER INT

1. *The unlisted pins are not connected.*

4 Bill of materials

Table 8. X-NUCLEO-IKS01A3 bill of materials

Item	Quantity	Reference	Part / value	Description	Manufacturer	Part number
1	4	C3, C6, C15, C31	10µF	CAP CER 0603 6.3 V X5R ±20%	MULTICOMP	MC0603X106M6R3CT
2	12	C4, C5, C8, C9, C11, C12, C13, C14, C16, C17, C30, C80	100nF	CAP CER 0603 25 V X7R ±10%	MULTICOMP	MC0603B104K250CT
3	1	C18	2.2µF	CAP CER 0603 25 V X5R ±10%	MULTICOMP	MC0603X225K100CT
4	1	C32	220nF	CAP CER 0603 25 V X7R 10%	KEMET	C0603X224K4RACTU
5	4	CN5, CN6, CN8, CN9	10x1, 8x1, 6x1, 8x1	Headers	4UCON	-
6	1	J1	-	DIL24 Socket	MULTICOMP	2212S-12SG-85
7	7	JP1, JP2, JP3, JP4, JP11, JP13, JP14	2x1	Header + Shunt	HARWIN	M20-9990246
8	4	JP5, JP9, JP10, JP12	-	Header + Shunt	Generic Components	2211S-03G
9	1	JP6	2x7	Header	Generic Components	61301421121
10	2	JP7, JP8	-	Header + 2 shunts	Generic Components	2211S-04G
11	10	R1, R2, R9, R10, R11, R12, R14, R15, R16, R17	4k7	RES 0603 ±1% 1/16 W	MULTICOMP	MC0063W060314K7
12	2	R3, R8	2k2	RES 0603 ±1% 1/16 W	MULTICOMP	MC0063W060312K2
13	1	R6	12k	RES 0603 ±1% 1/16 W	MULTICOMP	MC0063W0603512K
14	1	R7	15k	RES 0603 ±1% 1/16 W	MULTICOMP	MC0063W0603515K
15	1	R13	7K5	RES 0603 ±0.5% 1/16 W	SUSUMU	RR0816P-752-D
16	34	SB2, SB3, SB5, SB7, SB8, SB11, SB12, SB13, SB15, SB19, SB23, SB24, SB25, SB26, SB27, SB28, SB29, SB31, SB32, SB33, SB34, SB35, SB36, SB39, SB40, SB41, SB42, SB43, SB44, SB45, SB46, SB47, SB48, SB49	-	Solder Bridge	-	-
17	1	U1	LIS2DW12	3-axis MEMS accelerometer	ST	LIS2DW12
18	1	U2	LSM6DSO	iNEMO 6DoF inertial measurement unit	ST	LSM6DSO

Item	Quantity	Reference	Part / value	Description	Manufacturer	Part number
19	1	U3	HTS221	Digital sensor for relative humidity and temperature	ST	HTS221
20	1	U4	LPS22HH	MEMS nano pressure sensor	ST	LPS22HH
21	1	U5	LDK130M-R	300 mA low quiescent current very low noise LDO	ST	LDK130M-R
22	2	U6, U7	ST2378E	8-Bit Level Translator with 15kV ESD Protection	ST	ST2378E
23	1	U8	LIS2MDL	Magnetic sensor digital output 50 gauss	ST	LIS2MDL
24	1	U9	STTS751	2.25 V low-voltage local digital temperature sensor	ST	STTS751
25	1	U10	NTS0104GU12	IC TXRX TRANSLATING 2BIT 8XSON	NXP	NTS0104GU12
26	1	U11	LDK120PU25	200 mA low quiescent current very low noise LDO	ST	LDK120PU25R

5 Schematic diagrams

Figure 8. X-NUCLEO-IKS01A3 board schematics

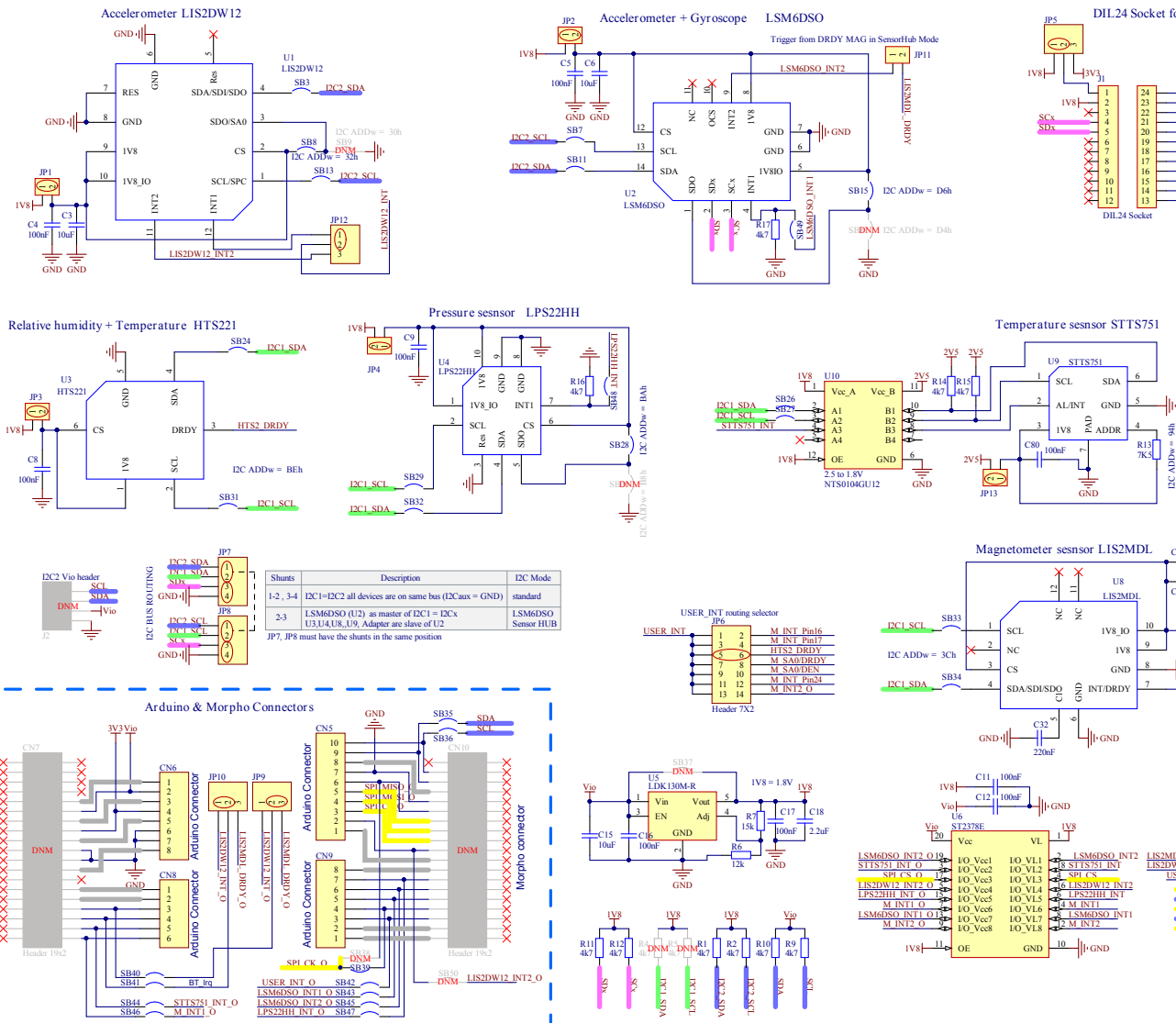

Revision history

Table 9. Document revision history

Date	Version	Changes
18-Feb-2019	1	Initial release.

Contents

1	Getting started	2
1.1	Hardware requirements	2
2	System requirements	3
3	Hardware description	4
3.1	Default solder bridge configuration	4
3.2	Block diagram	5
3.3	Sensor I ² C address selection	7
3.4	Sensor current consumption measurement	7
3.5	Sensor disconnection	8
3.6	Adapter board for DIL24 socket	8
3.7	Connectors	8
4	Bill of materials	10
5	Schematic diagrams	12
	Revision history	13
	Contents	14
	List of tables	15
	List of figures	16

List of tables

Table 1.	Default solder bridge default configuration (device to I ² C bus connection)	4
Table 2.	Device I ² C address.	5
Table 3.	Solder bridges for SD0 level control and I ² C address	7
Table 4.	Jumpers for current consumption measurement.	7
Table 5.	Link between sensors, jumpers and I ² C solder bridges	8
Table 6.	Arduino R3 UNO connectors	8
Table 7.	ST morpho connectors	9
Table 8.	X-NUCLEO-IKS01A3 bill of materials	10
Table 9.	Document revision history	13

List of figures

Figure 1.	X-NUCLEO-IKS01A3 expansion board	1
Figure 2.	X-NUCLEO-IKS01A3 plugged on an STM32 Nucleo board	2
Figure 3.	X-NUCLEO-IKS01A3 standard I ² C	5
Figure 4.	X-NUCLEO-IKS01A3 LSM6DSO I ² C sensor hub	6
Figure 5.	X-NUCLEO-IKS01A3 DIL24, LSM6DSO I ² C sensor hub (all sensors)	6
Figure 6.	X-NUCLEO-IKS01A3 LSM6DSO, DIL24, I ² C sensor hub (all sensors)	6
Figure 7.	X-NUCLEO-IKS01A3 LSM6DSO plus sensor hub DIL24	7
Figure 8.	X-NUCLEO-IKS01A3 board schematics	12

IMPORTANT NOTICE – PLEASE READ CAREFULLY

STMicroelectronics NV and its subsidiaries (“ST”) reserve the right to make changes, corrections, enhancements, modifications, and improvements to ST products and/or to this document at any time without notice. Purchasers should obtain the latest relevant information on ST products before placing orders. ST products are sold pursuant to ST’s terms and conditions of sale in place at the time of order acknowledgement.

Purchasers are solely responsible for the choice, selection, and use of ST products and ST assumes no liability for application assistance or the design of Purchasers’ products.

No license, express or implied, to any intellectual property right is granted by ST herein.

Resale of ST products with provisions different from the information set forth herein shall void any warranty granted by ST for such product.

ST and the ST logo are trademarks of ST. All other product or service names are the property of their respective owners.

Information in this document supersedes and replaces information previously supplied in any prior versions of this document.

© 2019 STMicroelectronics – All rights reserved