

"Schutzvermerk nach DIN ISO 16016 beachten" - "Please pay attention to copyright note DIN ISO 16016"

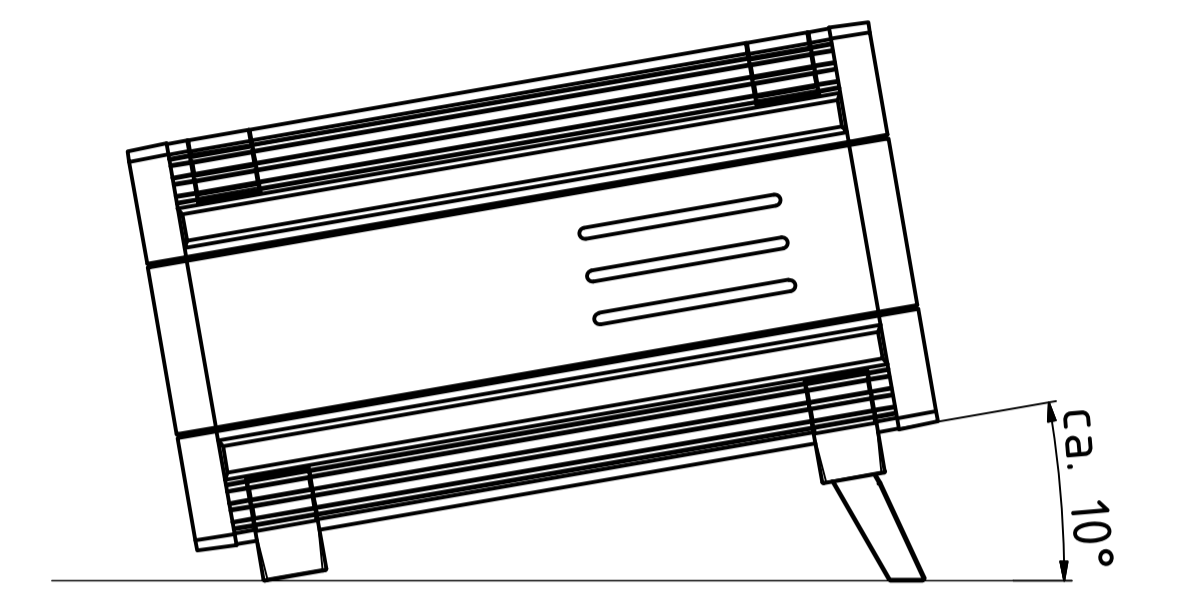

ISO (1 : 2)

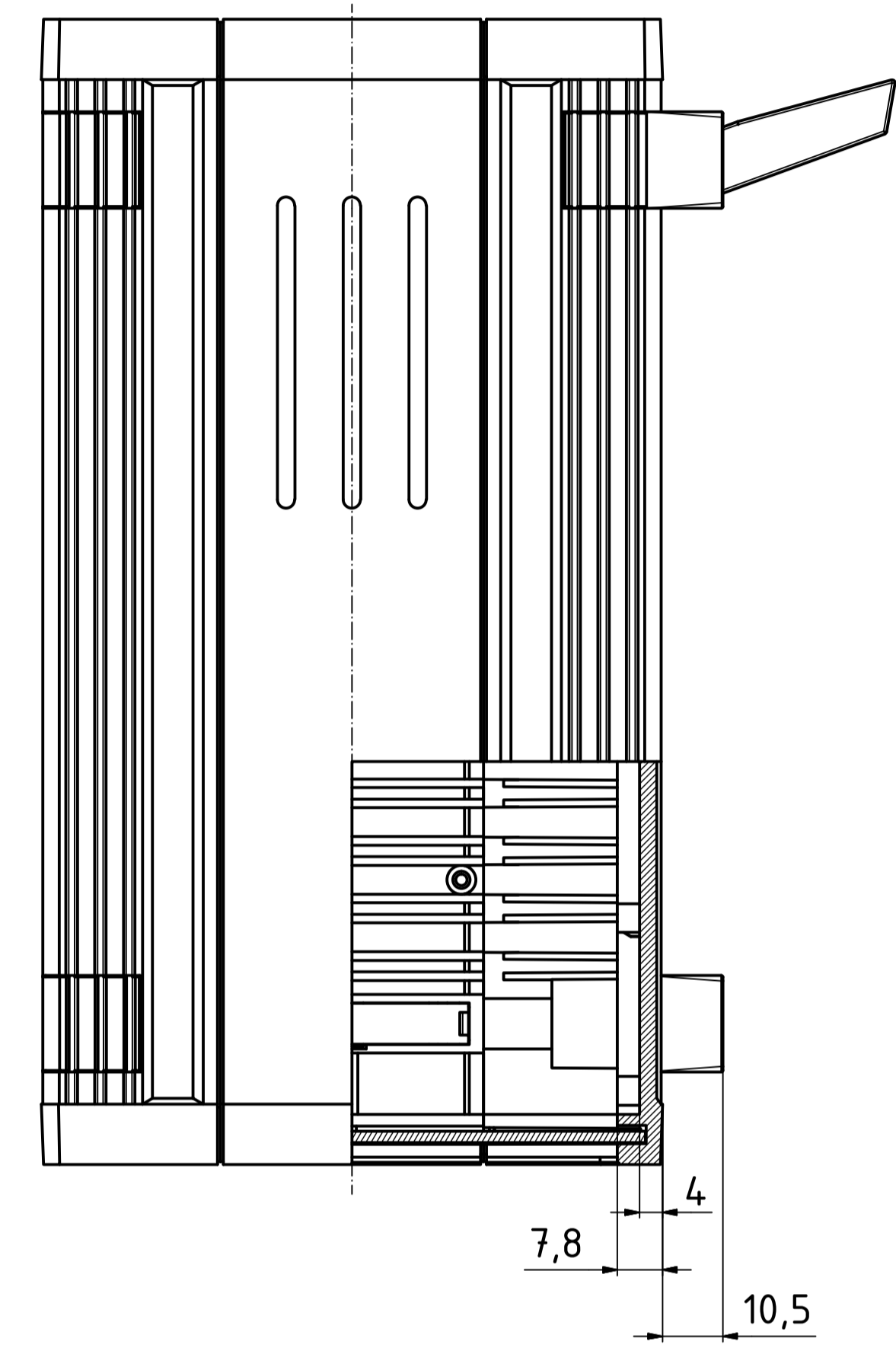
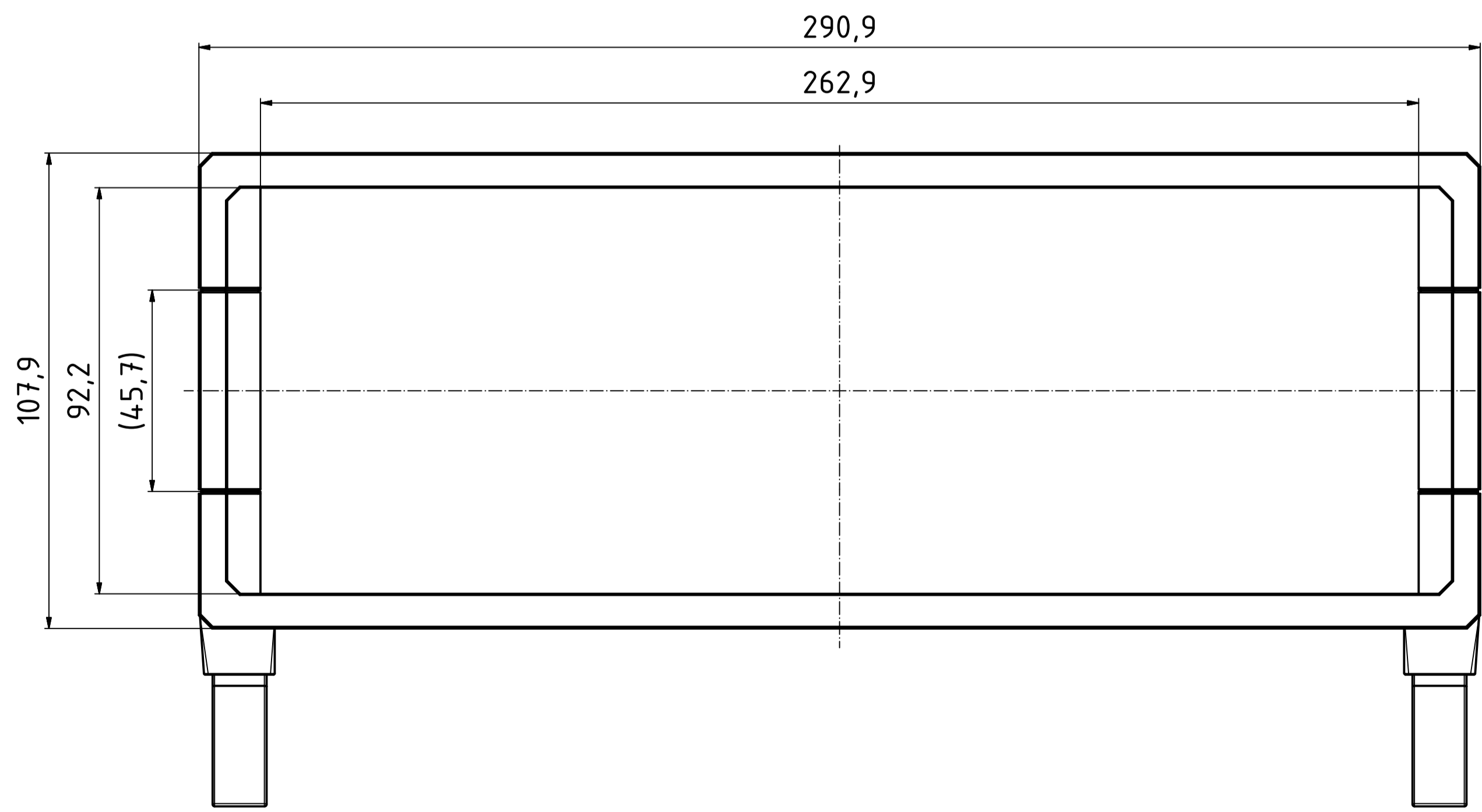
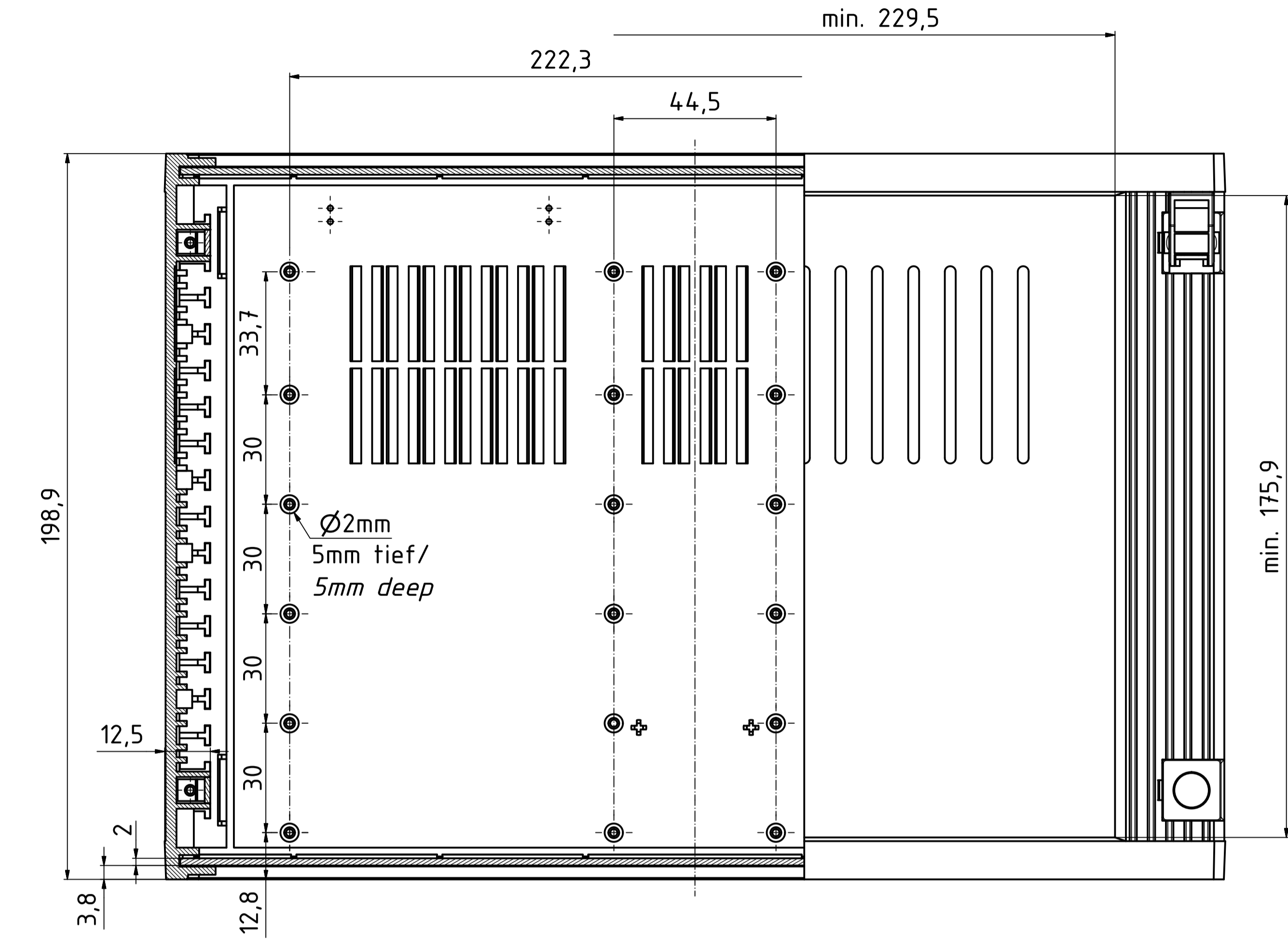
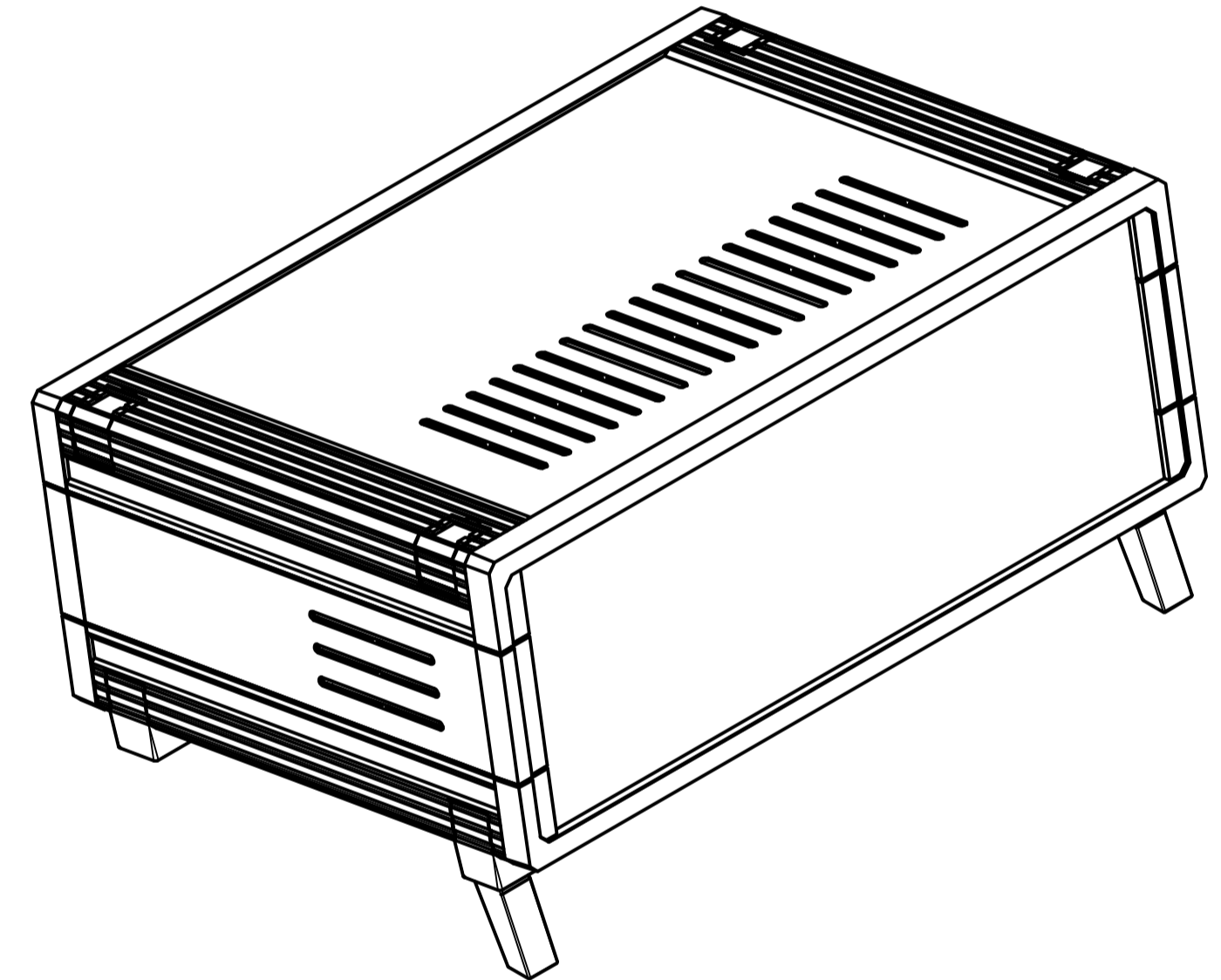

Maßstab/ Scale:	1:1 (1:2)	
Zeichnungs-Nr. / Drawing-No.:		
Artikel / Article:	UM 62018 L Katalogzeichnung Catalogue drawing	
A.Nr. / Art.No.:	Datum/ Date:	
DISK: 55620010_UM 62018 L + ASK.idw Datum/Date: 02.02.2018 AR		



BOPLA
A Phoenix Mecano Company